

ATLIN ACRYLIC ROLL TOP TUB

Cat. No.
ATR67



L: 67"
W: 29 1/2"
H: 24" (from floor)
18" (from bottom of tub)

Water Depth: 11-1/2" to OF

Compliance Certification
Meets or exceeds the following specifications: ASME A112.19.2 2013 and CSA B45.1-13 for ceramic plumbing fixtures.

The following is recommended for ATR67 tubs:

- Tub wall-mounted faucets: **#4022, 4035 or 4035**
- Double offset bath supplies: part **#5576**
- Leg tub drain: part **#5599**

Do Not Use with rigid, freestanding supplies.

Gallon Capacity: 50
Shipping Weight: 150 lbs.
Empty Weight: 100 lbs.
Filled Weight: 518 lbs.

Features:

- ▶ 3-3/8" centers in tub wall with continuous rolled rim
- ▶ Outside is textured fiberglass reinforced polyester coated with two-part epoxy
- ▶ Overflow hole is drilled
- ▶ Feet are attached and leveled before shipment
- ▶ Tub is thoroughly inspected before shipment
- ▶ Cast aluminum ball and claw feet.



Tub Colors

WH White **BQ** Bisque

Foot Finishes

BQ Bisque	BN Brushed Nickel
BL Black	ORB Oil Rubbed Bronze
PB Polished Brass	PN Polished Nickel
CP Polished Chrome	WH White

Custom Colors Available (inside of tub is always white enamel):
Painted bathtubs are considered "special order" and are not returnable
\$160 Bisque or Black \$250 Designer Color

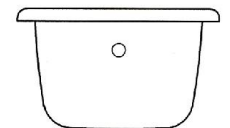
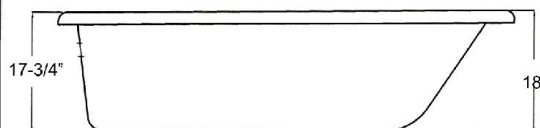
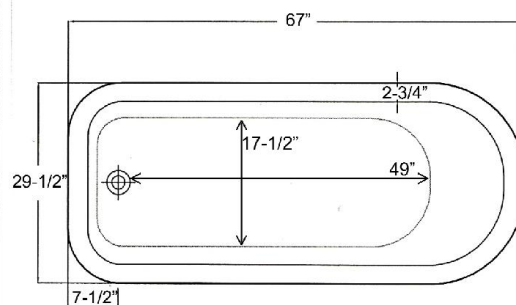

Dimensions of fixture are nominal and specifications subject to change without notice.