

**MERRICK  
69" ACRYLIC DOUBLE  
SLIPPER TUB**

Cat. No.  
ATDSN69I



L: 69"  
W: 28"  
H: 30"

Water depth: 16" to top of tub  
Water depth: 13 1/4 to OF

**Compliance Certification**  
Meets or exceeds the following specifications: ASME A112.19.2 2013 and CSA B45.1-13 for ceramic plumbing fixtures.

**The following is recommended for ATDSN69I tubs:**

- Faucets: part #4602, 4022 or 4025
- Rigid, freestanding supplies: part #4502
- Leg tub drain: part #5599LT



Overflow can be drilled. With overflow drilled this tub requires drain 5599PD. **Tubs that have been drilled with overflow are "special order" and are not returnable.**

Gallon Capacity without OF: 46  
Gallon Capacity with OF: 36  
Shipping Weight: 425 lbs.  
Empty Weight: 200 lbs.  
Filled Weight without OF: 584 lbs.  
Filled Weight with OF: 501 lbs.

**Features:**

- ▶ Interior and exterior walls acrylic sheets
- ▶ Space between walls partially filled with fiberglass & resin
- ▶ Aluminum imperial feet available in 4 finishes
- ▶ No faucet holes
- ▶ No overflow
- ▶ Tub feet are attached and leveled before shipment.
- ▶ Tub is thoroughly inspected before shipment

**Feet Finishes:**

- BN** Brushed Nickel
- CP** Polished Chrome
- PB** Polished Brass
- ORB** Oil Rubbed Bronze



**Custom Colors Available** (inside of tub is always white enamel):  
Painted bathtubs are considered "special order" and are not returnable  
\$160 Bisque or Black \$250 Designer Color

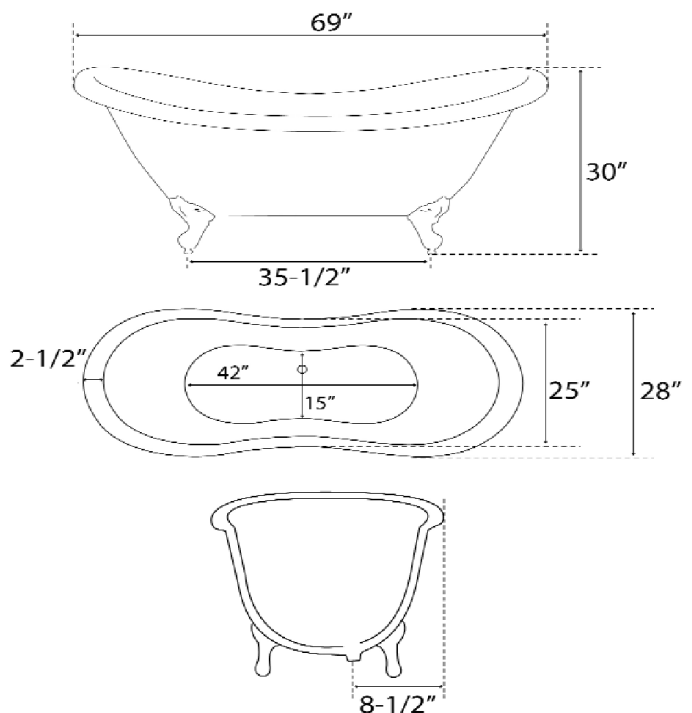

Dimensions of fixture are nominal and specifications subject to change without notice.