

**FILLMORE
DOUBLE ACRYLIC
SLIPPER TUB**

Cat. No.
ADTS60



L: 60"
W: 30"
H: 22-1/2" (from floor) short end
32" (from floor) tall end

Water Depth: 11-1/2" to OF

Compliance Certification
Meets or exceeds the following specifications: ASME A112.19.2 2013 and CSA B45.1-13 for ceramic plumbing fixtures.

The following is recommended for ADTS60 slipper tubs:
•Faucets: part #4602, 7393, or 7410
•Freestanding Bath Supplies: #4502-PL
•Leg tub drain: part #5599

Gallon Capacity: 33
Shipping Weight: 120 lbs.
Empty Weight: 62 lbs.
Filled Weight: 338 lbs.

Features:

- ▶ Inside finish is either white or bisque to match outside color
- ▶ Pre-drilled overflow hole
- ▶ No faucet holes
- ▶ Aluminum ball and claw feet available in 8 finishes
- ▶ Smooth acrylic surface inside and out
- ▶ Tubs ship with feet attached and leveled
- ▶ Tubs are thoroughly inspected before shipment



Tub Colors

WH White BQ Bisque

Foot Finishes

BQ Bisque	BN Brushed Nickel
BL Black	ORB Oil Rubbed Bronze
PB Polished Brass	PN Polished Nickel
CP Polished Chrome	WH White

Custom Colors Available (inside of tub is always white enamel):
Painted bathtubs are considered "special order" and are not returnable
\$160 Bisque or Black \$250 Designer Color

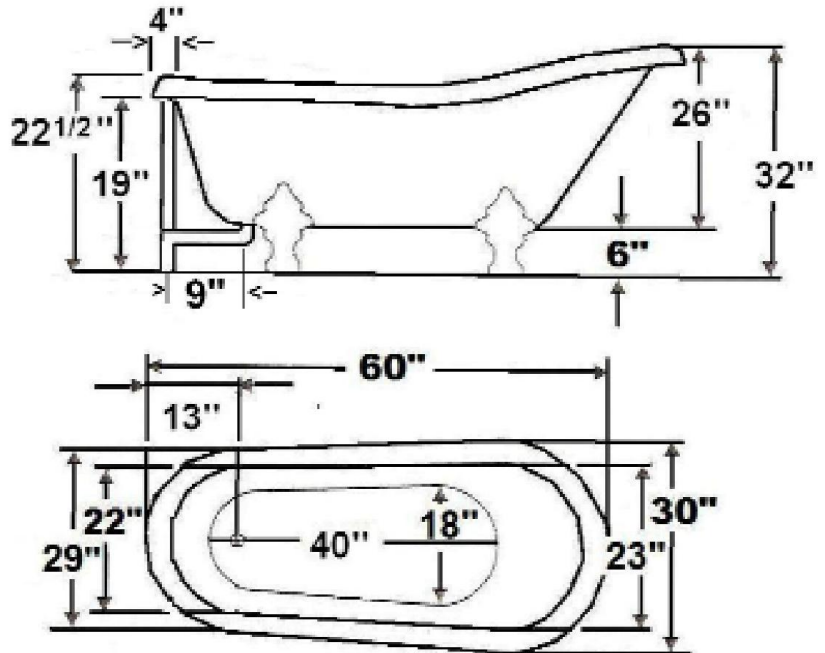

Dimensions are nominal and specifications subject to change without notice.