

Stella di Caffè



TECHNICAL NOTE

Thank you for choosing UNIC, the first French manufacturer of professional espresso machines since 1919.

The manufacturer reserves the right to modify the appliances presented in this publication without notice.
Read carefully the safety instructions before use.

NZ9009 01/15

UNIC

- 1. SAFETY INSTRUCTIONS5
- 2. IMPORTANT INFORMATION5
- 3. PRESENTATION OF THE STELLA DI CAFFÈ6
 - STEAMAIR OPTION 6
 - DUAL CONTROL OPTION (DCL)..... 6
- 4. FEATURES OF THE STELLA DI CAFFÈ7
 - Unpacking the machine 7
 - Preparation of the location and installation of the machine 7
- 5. COMMISSIONING7
 - WATER CONNECTION 7
 - Water supply 7
 - Draining 8
 - ELECTRICAL CONNECTION 8
 - CHECK THE TOROIDAL TRANSFORMER IN RELATION TO THE MAINS VOLTAGE..... 9
 - SWITCHING ON..... 9
 - FILLING THE BOILERS..... 10
 - Steam boiler..... 10
 - Group boilers 10
 - SWITCHING ON THE HEATING 10
 - WHEN THE MACHINE IS WARMED UP 10
 - INSPECTION AND ADJUSTMENT 11
 - Adjusting the temperature 11
 - Adjusting the high pressure valve..... 11
 - Adjusting the pump pressure..... 12
 - Adjusting the water inlet solenoid valve 12
- 6. INTERFACE13
 - MENU DESCRIPTION 13
 - BROWSING THE MENU 14
 - SPECIAL MENU FUNCTIONS 14
- 7. PROGRAMMING.....15
 - CODES (LEVELS 1, 2 AND 3)..... 15
 - To enable a level..... 15
 - Change the password (level 1, 2 and 3)..... 15
 - SETTINGS..... 16
 - Date & Time (levels 1, 2 and 3)..... 16
 - Language (levels 1, 2 and 3)..... 16
 - Sound (levels 1, 2 and 3)..... 17
 - Wallpaper (levels 1, 2 and 3)..... 17
 - Light bar backlighting and keyboards (levels 1, 2 and 3) 18
 - MACHINE ADJUSTMENT (LEVEL 1, 2 AND 3) 19
 - GROUP ADJUSTMENT (LEVEL 1, 2 AND 3)..... 19
 - Temperature adjustment (level 1, 2 and 3)..... 20
 - Dose adjustment (levels 1, 2 and 3)..... 20
 - Pre-infusion adjustment (levels 1, 2 and 3) 21
 - Self time adjustment (levels 1, 2 and 3)..... 23
 - STEAM ADJUSTMENT (LEVEL 1, 2 AND 3) 23
 - STEAMAIR & HOT WATER ADJUSTMENT (LEVELS 1, 2 AND 3)..... 24
 - MISCELLANEOUS (LEVELS 1, 2 AND 3) 25
 - Continuous/stop cycle key 26
 - Counter 28

- 8. USE32**
 - DOSAMAT CONTROL BOX (PART NUMBER 45100)..... 32
 - 2-CUP CONTROL BOX (4-DOSE PART NUMBER: 45102)..... 32
 - 3-CUP CONTROL BOX (6-DOSE PART NUMBER: 45103)..... 33
 - MANUAL CONTROL BOX (ON/OFF PART NUMBER: 45101) 34
 - **STEAMAIR** CONTROL BOX (PART NUMBER 45104)..... 34
 - HOT WATER/MANUAL TAP CONTROL BOX (PART NO 45105) 35
 - **STEAMAIR** OPTION..... 35
 - DUAL CONTROL OPTION (DCL)..... 36
- 9. CLEANING AND MAINTENANCE37**
 - AFTER EVERY USE..... 37
 - DAILY 37
 - *Semi-automatic cleaning*..... 37
 - *Semi-automatic rinsing*..... 39
 - WEEKLY 41
 - FRONT PANEL CLEANING 41
 - CLEANING THE **STEAMAIR** OUTLET 42
 - OTHERS 42
- 10. MAINTENANCE AND REPAIRS43**
 - UPDATE PROCEDURES..... 43
 - *BTA update* 43
 - *CPU update*..... 43
 - BGX/BST UPDATE..... 44
 - ASSIGNMENT OF ONE OR MORE BGX/BST CONTROL BOXES..... 45
 - USING CIM-CREATOR..... 46
 - DIAGRAMS 48
 - *BGX control box connections* 48
 - *BTA & BST control box connections*..... 49
 - *CPU board connections*..... 50
 - *Lights and straps*..... 51
 - *Hydraulic diagram* 53
 - *Fuses* 55
 - *Wiring diagrams* 56
 - FITTING / REPLACEMENT PROCEDURES 59
 - *Mother board replacement (CPU)* 59
 - *BTA/BGX/BST control box replacement*..... 60
 - *Fitting the long feet* 62
 - Rear feet (all versions)* 62
 - Front feet (standard version)* 62
 - Front feet (V+ version)* 63
 - *Removal / replacement of the steam tap cartridge* 63
 - TROUBLESHOOTING 64
 - *List of fault codes for the technician*..... 64
 - *Troubleshooting*..... 70
 - *Replacing a faulty control box:*..... 70
 - Replacing the BTA control box*..... 70
 - Replacing the BGX /BST control box* 70
 - *Individual test procedure for internal components* 71
 - COOLING 75
 - COMPUTER SYSTEM 75
 - *Debit – Credit system*..... 80
 - *Credit – Debit system and RS232*..... 81
 - SYSTEM INFORMATION 82

11. STELLA PROGRAMME FLOWCHART	83
➤ LEVEL 0: USER.....	83
➤ LEVEL 1: COFFEE SPECIALIST	84
➤ LEVEL 2: BARISTA	85
➤ LEVEL 3: MANAGER / BOSS.....	86
➤ LEVEL 4: TECHNICIAN	87
12. APPENDICES	88

1. SAFETY INSTRUCTIONS

- This machine is not intended to be used by persons (including children) with diminished physical, mental or sensorial capacities, or lacking in experience and savoir faire, unless they are supervised or have received training in the use of the machine from a person responsible for their safety.
- Children should be supervised to ensure that they do not play with the machine.
- This machine must only be used for its specific intended use.
- The manufacturer accepts no responsibility for damage caused by abnormal or incorrect use.
- Access to the service area is limited to persons having the necessary health and safety expertise and practical experience of the machine.
- Before connecting or disconnecting the supply cable set the main switch to the 0 position.
- If the supply cable is damaged it should be replaced by the manufacturer, his repairer or a similar qualified person to avoid danger.
- For electrical safety make sure that the machine is properly earthed.
- The manufacturer accepts no responsibility for damage caused by faulty grounding connections.
- Only qualified technicians are authorised to access the internal parts of the machine for maintenance or repair.
- Use caution around hot surfaces such as the cup warmer, the group heads and the hot water and steam outlets.
- Keep well clear of hot water or steam jets.

2. IMPORTANT INFORMATION

This machine must be:

- Placed on a stable horizontal surface
- Used at an ambient temperature between 5°C and 35°C (41°F – 95°F).
- Installed in compliance with any applicable local and national regulations.
- Connected to a water supply at a pressure between 1 and 8 bars
(0.1 to 0.8 Mega Pascal)

Before connecting the electricity supply, check that the mains supply complies with the specifications on the manufacturer's plate on the machine.

For more details on the installation, adjustment or connections refer to the installation instructions or the technical manual.

This machine should not be exposed to water jets or splashes.

Take care not to obstruct the machine air inlets with cloths or other objects.

If the machine is stored at an ambient temperature below 5°C (41°F) the hydraulic circuit (boiler and pipework) must be drained.

3. PRESENTATION OF THE STELLA DI CAFFÈ

The Stella di Caffè has the advantage of having an independent boiler for each group, in addition to a large capacity steam boiler. All the machine operating settings can be viewed and adjusted simply and intuitively from the touch screen.

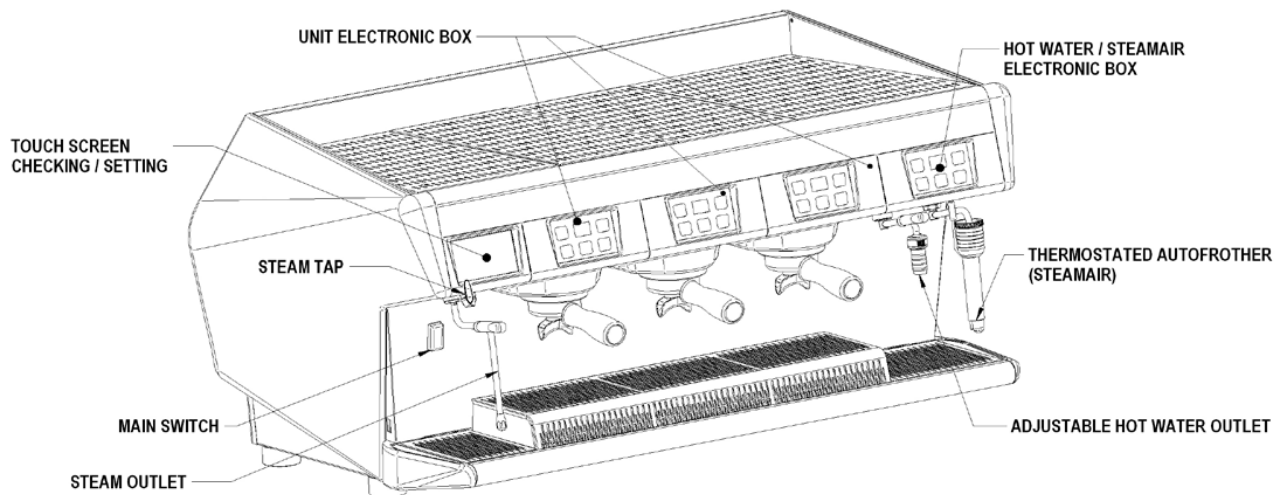

➤ **SteamAir Option**

The **SteamAir** option is particularly useful for making *cappuccino*, it serves to convert the milk into foam in a simple automatic operation: the injection of a mixture of air and steam (adjustable) heats the milk to a programmed temperature (60° to 70°) and at the same time turns it into foam.

The machine stops automatically when the milk reaches this temperature, so preventing it boiling

➤ **Dual Control Option (DCL)**

The dual control system makes it possible to manually control the infusion and pre-infusion. The automatic group control boxes remain fully functional when the DCL option is installed.

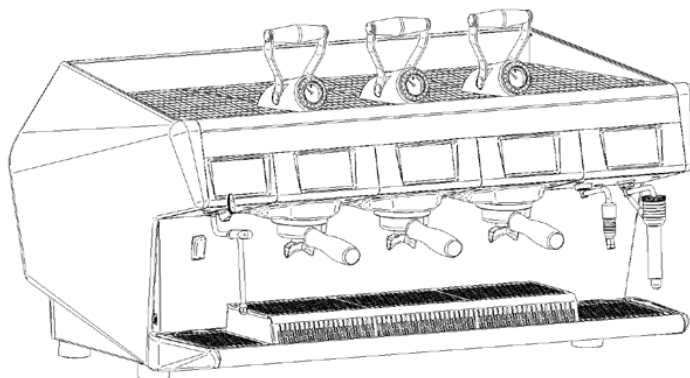

4. FEATURES OF THE STELLA DI CAFFÈ

The machine is delivered in a cardboard packing case and screwed to a wooden pallet.

- Unpacking the machine

Cut the bands

Open the box and take out the box holding the accessories

Separate the cardboard packing case from the pallet

Unscrew the nuts holding the machine to the pallet while tilting the control box slightly

Remove the machine from the pallet and place it on wooden blocks

Remove the screws and washers used for the transport

- Preparation of the location and installation of the machine

Position the machine in its final location and level it with rubber washers if necessary

It is essential to leave a free space of 5 cm behind the machine if it is against a wall

Take care never to obstruct the air intakes on the top of the machine

The machine requires an earthed electricity wall socket corresponding to the specifications on the machine, a water supply and a "waste water" drain with trap.

5. COMMISSIONING

➤ Water connection

Fit a filter upstream of the machine - Check the hardness of the water: 5° to 10° KH recommended – If necessary use a water softener.

- Water supply

- Pressure: 0 - 10 bars

- Connection: 3/8" female gas thread (male connection on the machine) - Supplied with the machine

- Pipe: minimum inside diameter 8 mm

- Install a stop tap on the supply

To connect the water it is necessary to remove the right side panel from the machine:

Unscrew the fixing screws next to the cup warmer and pull the side panel towards the back

Screw the elbow end (3/8") of the braided flexible pipe to the brass connection on the right of the machine, and the straight end (1/2") to the water mains connection or the water softener outlet (if used)

If a water softener is used, wash it out before using it.

Check for leaks

Refit the side panel on the machine

▪ Draining

- Pipe with a minimum inside diameter 15 mm: supplied with the machine

Tools required:
 - Flat screwdriver
 - Multigrip pliers

To connect the drain pipe to the machine, it is necessary to remove the overflow tray (remove the overflow tray grids, unscrew the 2 knurled screws and pull the overflow tray towards you) and the drain connection fixing screws.

Connect the drain pipe to the drain connection (to make the pipe easier to fit we recommend holding its end under hot water), and then reassemble in the reverse order of removal.

Connect the other end of the drain pipe to a waste water drain while making sure that there are no reverse slopes to hinder the flow.

➤ **Electrical connection**

CAUTION: The machine should be connected to a line fitted with a mains isolation switch.

The machine is delivered with a cable with 5 numbered cores.

Set the mains isolation switch to 0 before starting work.

Check that the voltage, frequency and power values on the manufacture's plate on the machine correspond with those of the mains

Check that the machine wiring corresponds with the power supply available, according to the connection diagrams below. If necessary change it by altering the positions of the jumpers in the connection block on the left of the machine.

CAUTION: to connect 230V with a 5 core cable, it is essential to connect the wires at the end of the cable correctly.

For 230 V single-phase: blue and black wires together, brown and grey wires together. Take care over the current capacity (32A)

For 230V 3-phase: brown and grey wires together. Caution, there is no neutral so the blue wire must be connected to a phase

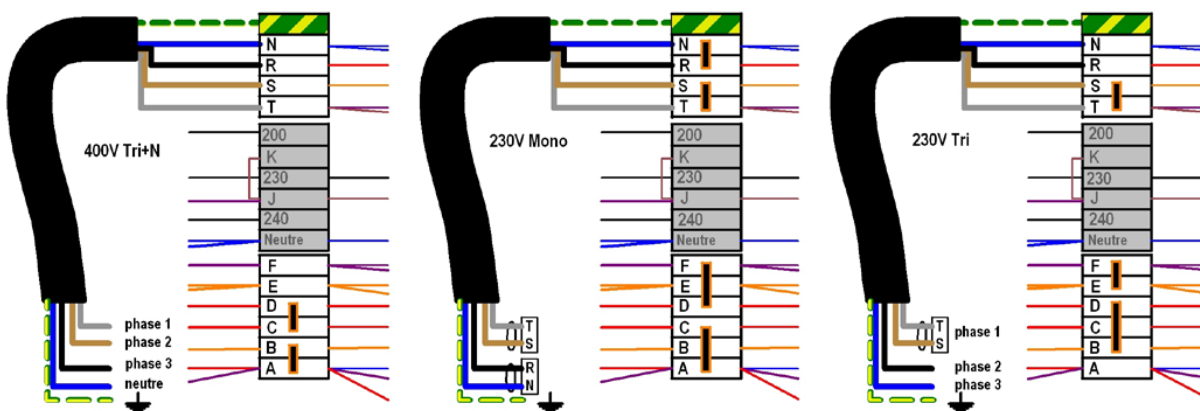

I = ponts a mettre en place en fonction de la tension du réseau

380V / 400V / 415V TRI + N +

200V / 230V / 240V MONO +

200V / 230V / 240V TRI +

IN ALL CIRCUMSTANCES THE GREEN/YELLOW WIRE MUST BE CONNECTED TO THE INSTALLATION GROUNDING CONDUCTOR

➤ **Check the toroidal transformer in relation to the mains voltage**

The machine is fitted with a multi-voltage transformer to ensure that the supply to the electronics is at the right voltage.

The machine is factory set according to its country of destination.

E.g.:

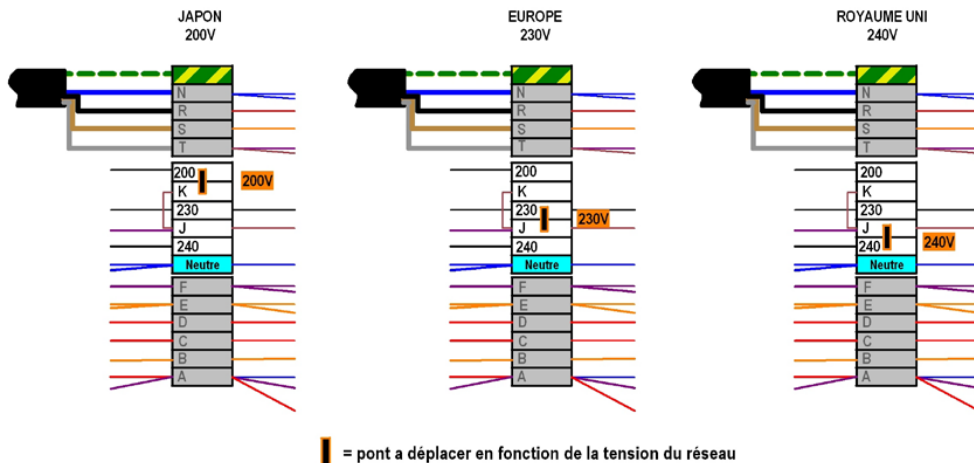

If it is necessary to change the factory setting, only the jumpers should be repositioned: no wiring should be moved.

➤ **Switching on**

When the power is switched on the machine performs an initialisation cycle that checks all the components; the starting up time is approximately **45sec**.



Never start up with the USB dongle inserted in the side of the machine

➤ Filling the boilers

As soon as the power is switched on the boilers fill automatically.

Remember to turn on the water stop valve.

- Steam boiler

A safety function is provided in case the boiler is not filled in within 3 minutes: the filling solenoid valve and the pump switch off.

In all cases:

Check the water supply to the machine

Switch the machine off and on again: switch the main isolation switch to 0 and then back to 1

Filling starts again

- Group boilers

A small amount of water should flow out of each group.

If not, the light bar above the faulty group flashes:

Check the water supply to the machine

Switch the machine off and on again: switch the main isolation switch to 0 and then back to 1

Filling starts again

➤ Switching on the heating

All the elements start heating automatically if filling is correct. When the machine reaches its operating temperature it is ready to work.

The steam pressure and the group temperatures are displayed on the screen.

We recommend leaving the machine with the heating switched on all the time, and leaving the filter holders in position on the machine when they are not in use.

➤ When the machine is warmed up

It is not possible to access the menu until the machine is warmed up. Once the machine is at its working temperature simply press the screen to obtain the menu.

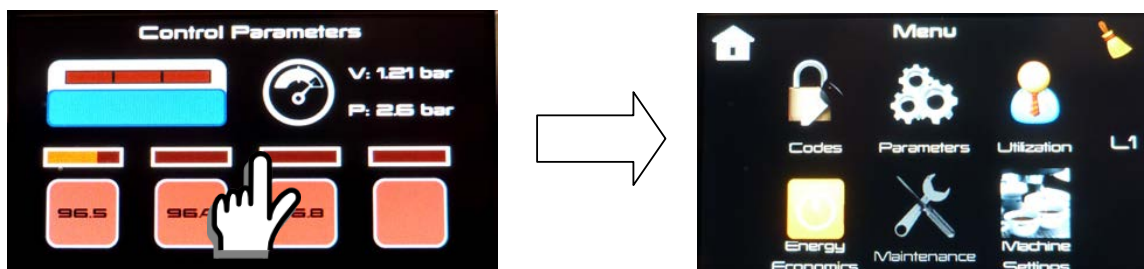

➤ Inspection and adjustment

Tool required:
- 2.5 mm Allen key

Normally all adjustments are made before the machine leaves the factory. Check that these adjustments are correct and change them if necessary; proceed as follows to access them:

You need to remove the right side panel of the machine:

Remove the screws next to the cup warmer and pull the side panel towards the back to remove it.

▪ Adjusting the temperature

The temperatures of each group and the steam boiler are adjusted independently from the control screen via the "adjustments" menu. (See the chapter entitled: MACHINE ADJUSTMENT)

▪ Adjusting the high pressure valve

The valve is on the front right of the machine

The pressure reading can be seen on the control screen

The valve should open at approximately 13 bars and vent a small amount of water into the drip tray during the group heating cycle.

- If it opens ABOVE 13 bars: turn the adjustment screw OUT

- If it opens BELOW 13 bars: turn the adjustment screw IN

Use a pin spanner. After adjustment remember to tighten the lock-nut.

Tools required:
- Pin spanner, part no: OU003
- 24mm open-end spanner

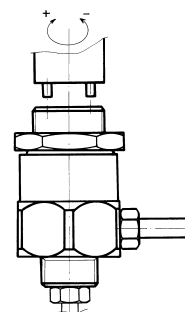
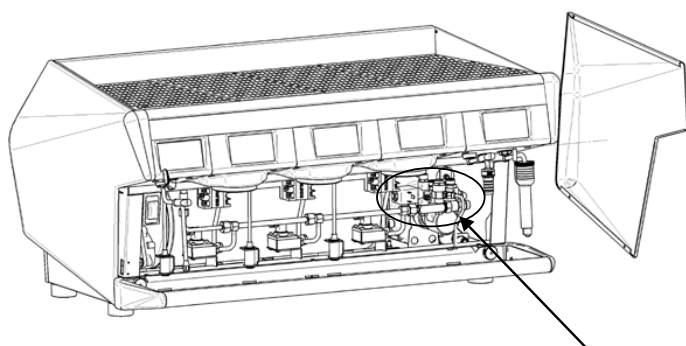

- Adjusting the pump pressure

The pump is on the right side and is adjusted from the same side. During infusion the pressure should be between 8 and 9 bars (displayed on the control / adjustment screen).

Turn the adjustment SCREW IN to increase the pressure

Turn the adjustment SCREW OUT to reduce the pressure

Tools required:
- Flat screwdriver

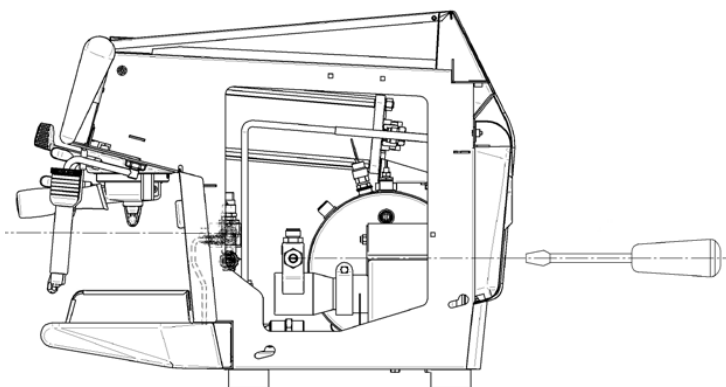

- Adjusting the water inlet solenoid valve

The water inlet solenoid valve is situated on the front right of the machine. It is accessible from the side.

Method:

With the machine at its working temperature run a cycle (with coffee) continuously on all the groups simultaneously.

Trigger the filling of the steam boiler (by running off hot water)

Adjust the maximum flow of the solenoid valve so that the pressure does not fall below 7 bars.

Then check that the boiler filling time is not excessively long.

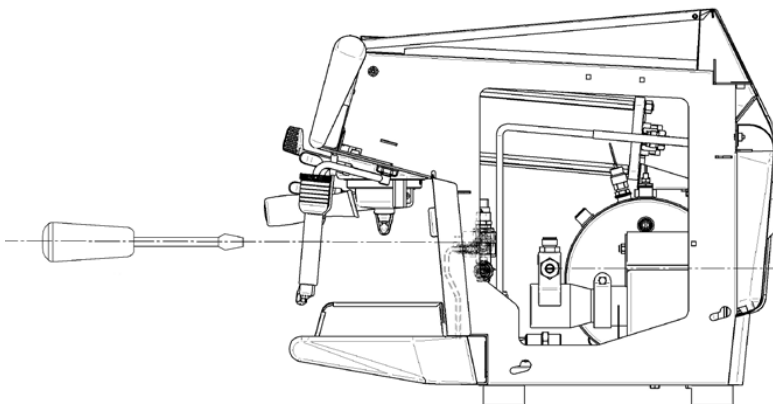

6. INTERFACE

➤ Menu description

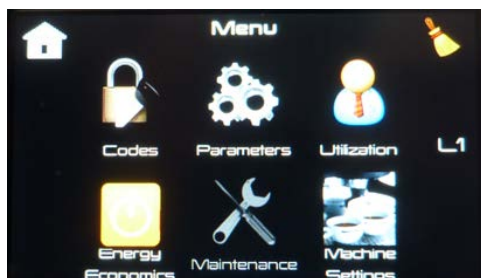

Codes: for accessing the various levels of the menu



Settings: for use or setting of: *date and time, language, sound, screen background, group and lighting.*



User: for use or setting of the following functions: *rinsing, cleaning groups, coffee counters, programming maintenance, light bar on / off and water softener.*



Energy saving: for use or setting of the following functions: *day/night, group stand-by, group stop, day/night programming*



Maintenance: for use or setting of the following functions: *component testing, fault code list, events log, cooling, CIM (Machine identity characteristic) and counters.*



Machine adjustments: for use or setting of the following functions: *group adjustment, temperature adjustment, dose adjustment, pre-infusion adjustment, self time adjustment, steam adjustment, **SteamAir**, shut-down of groups and miscellaneous.*



Faceplate cleaning: disables the sensitivity of the keyboards for cleaning the glass faceplate.

Greyed icons are **disabled** or **locked**. To use these functionalities you need:

- either the required level of access code
- or the USB dongle.

➤ Browsing the menu

The icons below represent all the browsing functionalities of the STELLA menu.

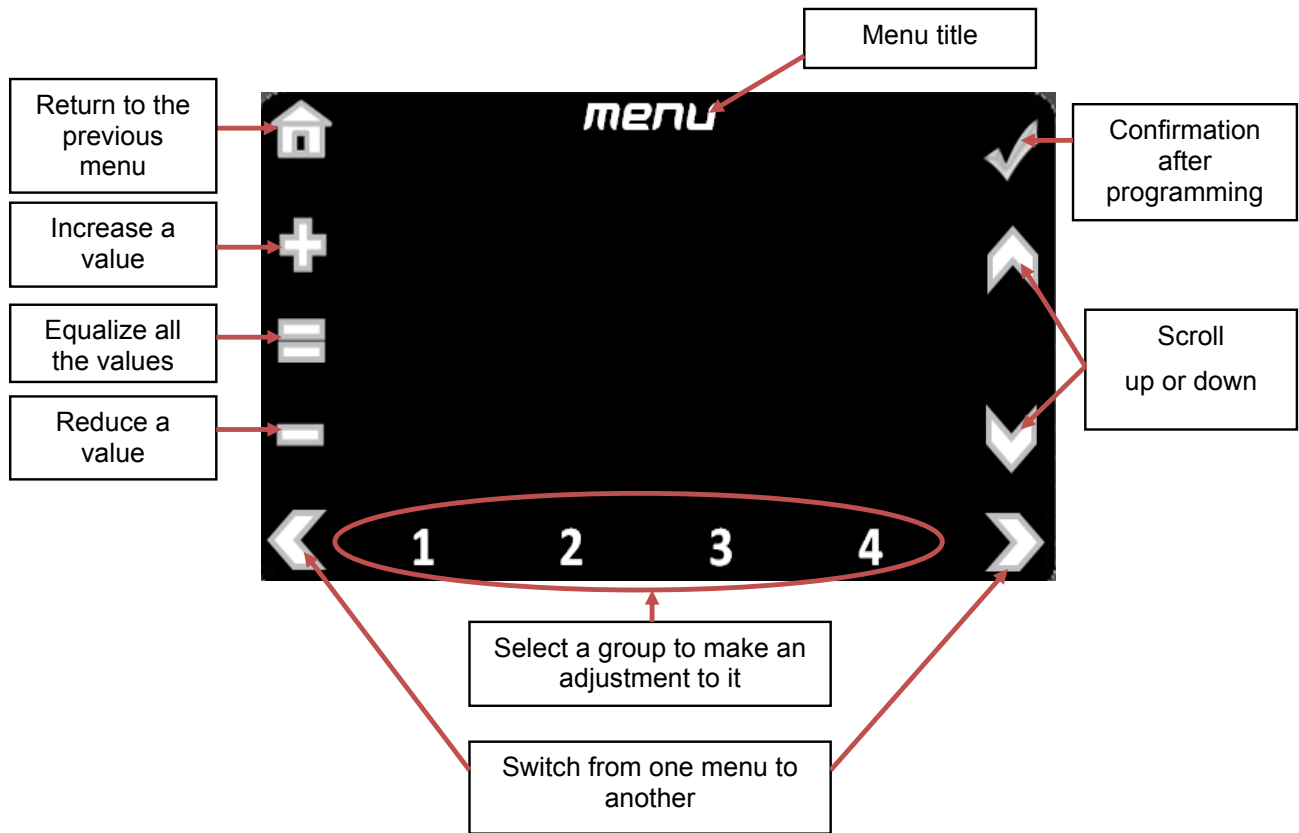

➤ Special menu functions

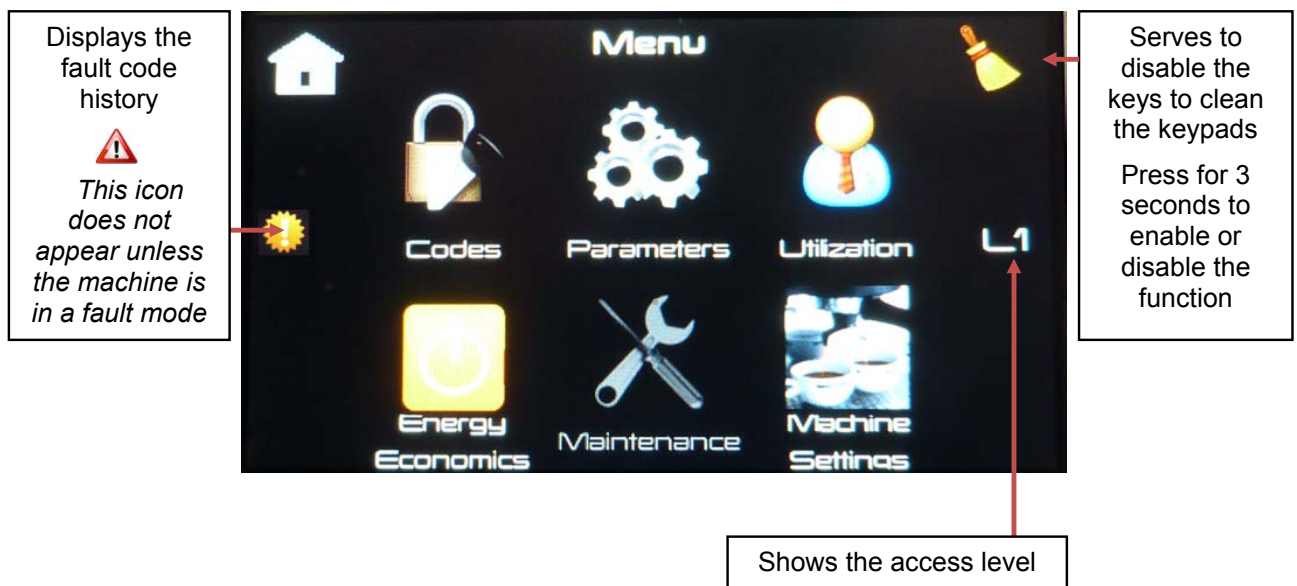

7. PROGRAMMING

➤ Codes (levels 1, 2 and 3)

Most of the menus are locked out by default. Adjustment and programming are impossible. Access to the adjustments is authorised by entering a code with three access levels. **For more information refer to the chapter entitled: "Stella programme tree structure".**

By default the codes are:

Level1 = 11111

Level2 = 22222

Level3 = 33333

- To enable a level

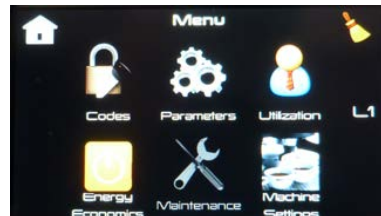
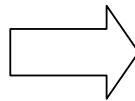
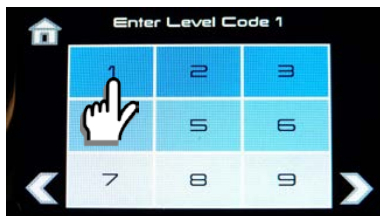
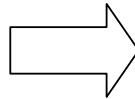
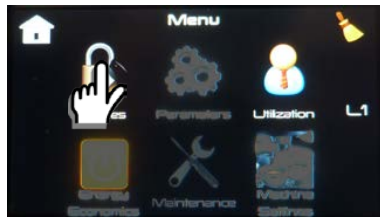

Enter the 5 digit code

Once the code entered, return to the main menu. The icons authorised for the level are no longer greyed.

Note: If the code entered is incorrect an error message appears. Start the entry again.

After entering the code, additional options become available by clicking on "codes" again.

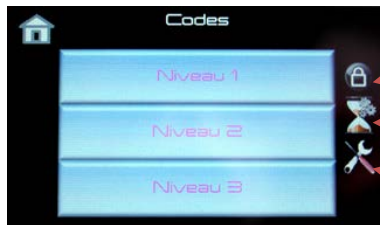

Exit from the current level

Disable the automatic switching back to 0 after 1 minute of inactivity

Change the current level password while it is use.

- Change the password (level 1, 2 and 3)

To change the password it is necessary to first enable this access level.

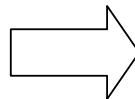
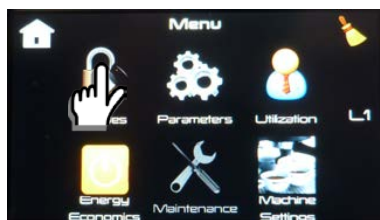

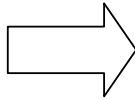

Enter the new level access code twice

➤ **Settings**

▪ Date & Time (levels 1, 2 and 3)

To adjust the date and the time

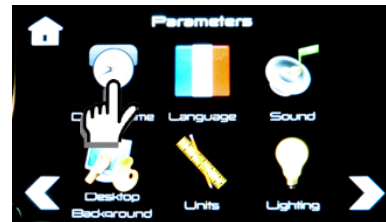
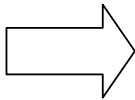

Use the + and - keys to adjust the desired value.

- ✓ When you select a value to make an adjustment, it turns pink.
- ✗ Confirm the adjustment to save the settings

▪ Language (levels 1, 2 and 3)

To choose the menu language

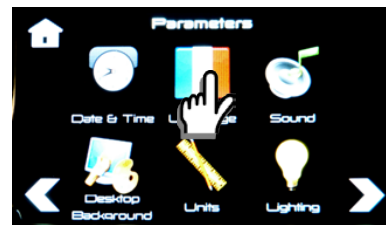
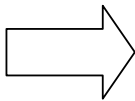
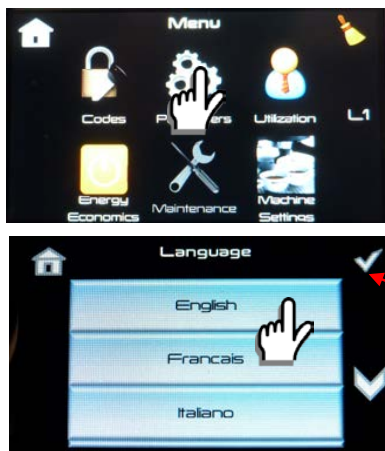

- ✓ Select the desired language
- ✓ Confirm the adjustment to save the settings

▪ Sound (levels 1, 2 and 3)

To activate or de-activate the sound and adjust the volume

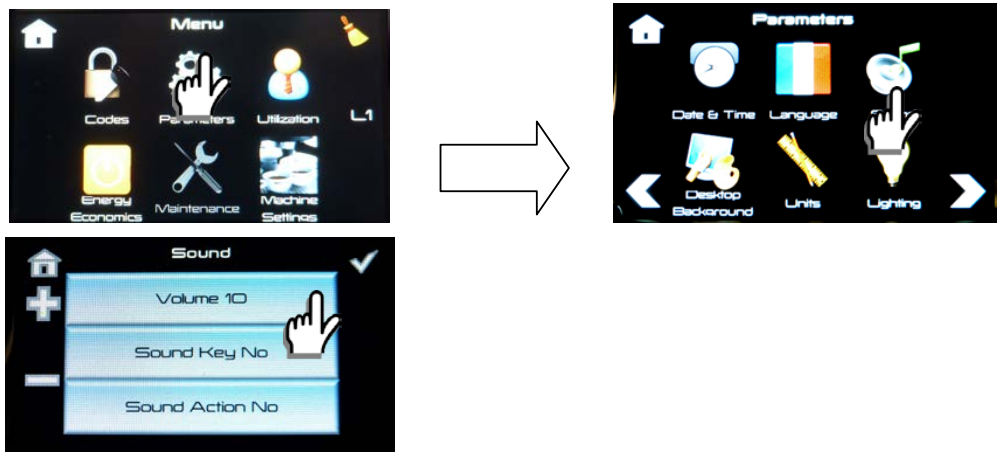

▪ Wallpaper (levels 1, 2 and 3)

The screen background can be an image / photograph or a display of the machine settings.

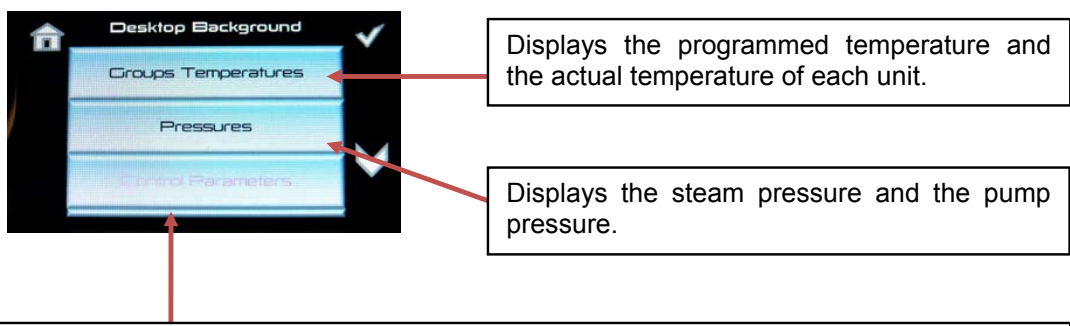
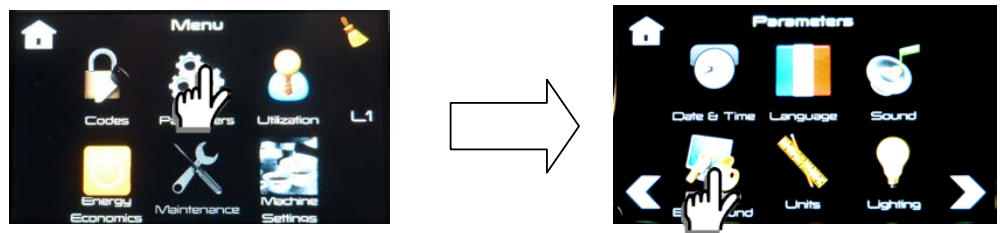

Display of the steam and pump pressures, the temperature of each unit and the level in the steam boiler. Cursors also show the activation of the heating elements **Recommended for all adjustments.**

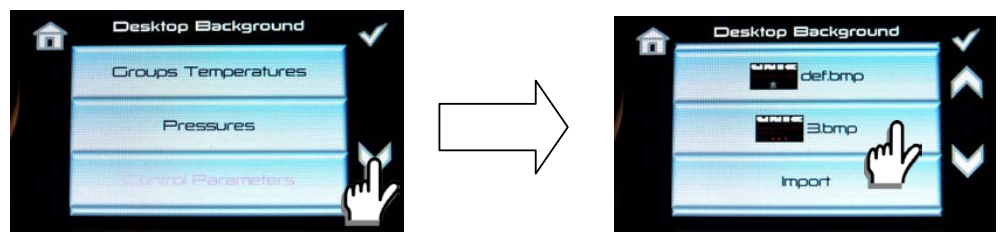

Select the wallpaper



View the wallpaper and confirm the wallpaper by pressing it

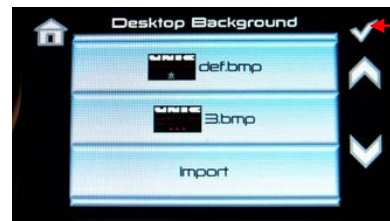
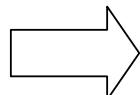

✓ Confirm the adjustment to save the settings.



Importing a screen background:

- Before importing a screen background insert the USB dongle in the side of the machine.
- The USB dongle and the images must be correctly configured for the machine to read them.



Contact your dealer for more information.

- Light bar backlighting and keyboards (levels 1, 2 and 3)

To change the colour of the strip and the keyboards.

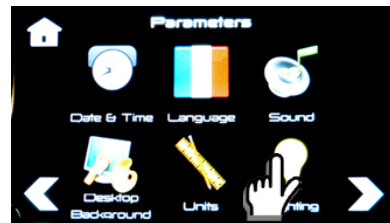
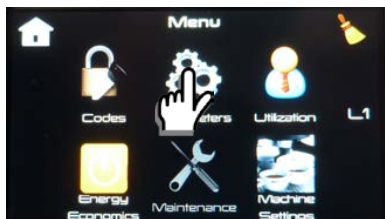

Use the + and – keys to adjust the desired value.

- ✓ When you select a value to make an adjustment, it turns pink.
- ✓ Remember to confirm the adjustment to save the settings.

The 'Lighting' screen shows a slider for 'Luminosity/Color Headband/Speed' with values 0, 61, and 10. Below it is a 'Key Color' section with a '170' value and a toggle icon. Callout boxes provide the following information:

- Light bar intensity adjustment:** Points to the left side of the slider.
- Keyboard colour adjustment:** Points to the 'Key Color' value.
- Light bar colour adjustment:** Points to the 'Key Color' value.
- Adjustment of the colour scrolling speed for the strip and the keyboards. (0 = fixed colour):** Points to the '0' value on the slider.
- Keyboard and Light bar colour scrolling enable / disable:** Points to the toggle icon.

Colour	Value
White	0
Red	1
Yellow	40
Green	80
Cyan	120
Blue	160
Pink	220
Red	255

➤ **Machine adjustment (level 1, 2 and 3)**

For making the adjustments specific to the coffee machine: temperature, dosing, pressure, etc...

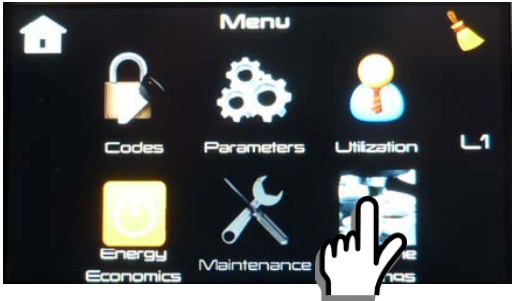

➤ **Group adjustment (level 1, 2 and 3)**

To adjust and view the temperatures of the groups, the pre-infusion, the self time and the doses.

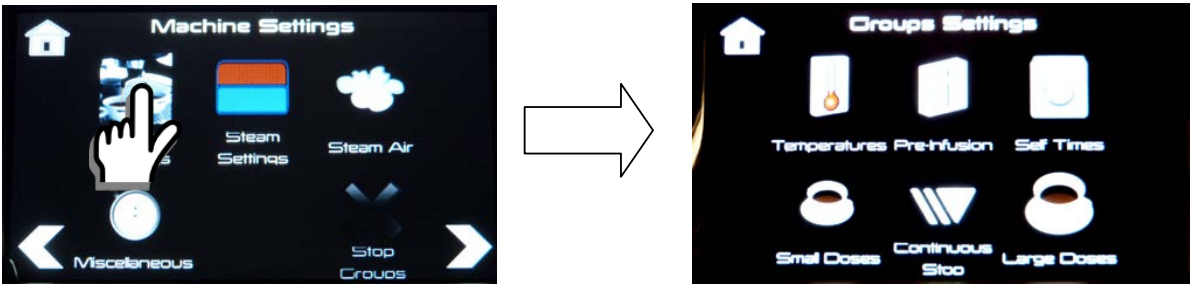

▪ Temperature adjustment (level 1, 2 and 3)

To adjust the temperature of each group.

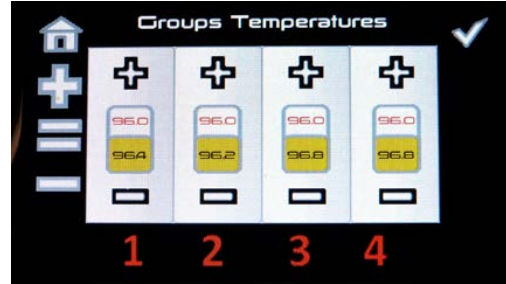
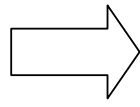
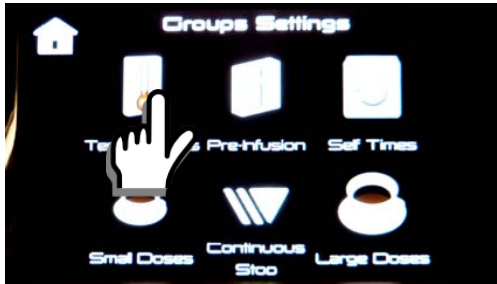

Programmed temperature.

Use the + and - keys to adjust the desired value.

✓ Confirm the adjustment to save the settings.

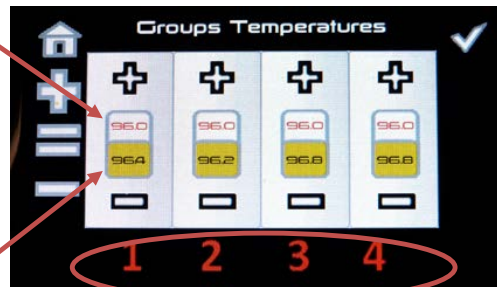

Actual temperature (sensor).

Select the group.

▪ Dose adjustment (levels 1, 2 and 3)

To adjust and view the doses.

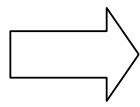
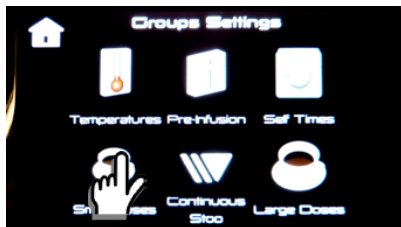

Activate the **PRO**gramming mode by pressing the icon on the right.

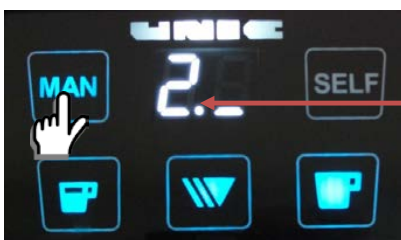
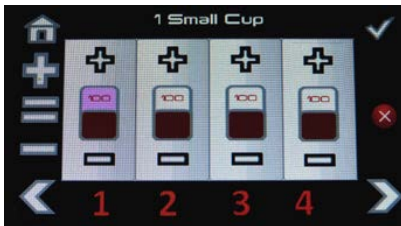

Flashing dot appears on the unit displays in the **PRO**gramming mode

If the MAN key is not lighted, press it (Only on DOSAMAT machines);

Engage the desired filter holder, e.g.: 1T, 2T or 3T

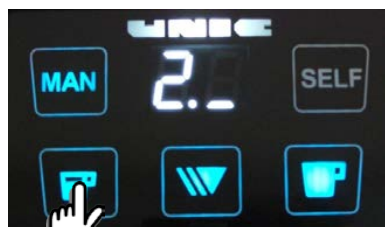

In this case, the two-cup filter holder is engaged.
Press small or large dose

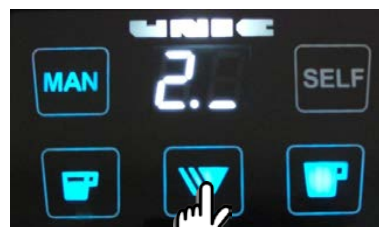

When the desired dose of coffee is reached stop the infusion with the "continuous/stop" key.



To obtain the same value on the other units press =

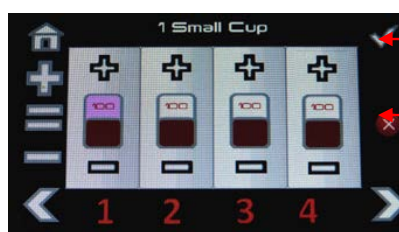

Press ✓ to confirm the new doses

Repeat the operation to adjust the other volumes

Disable the PROgramming mode to save the values

- Pre-infusion adjustment (levels 1, 2 and 3)

To adjust the coffee wetting time before infusion.

The "open" pre-infusion time is the time (**T1**) during which the solenoid valve remains open if the Stella is fitted with a pre-infusion solenoid valve.

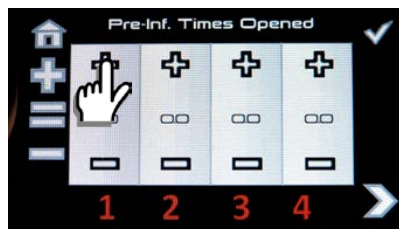

Use the + and – keys to adjust the desired value.

Adjustment range: 0.1sec to 10sec

✓ Confirm the adjustment to save the settings.

The "closed" pre-infusion time is the time (**T2**) during which the solenoid valve remains closed.

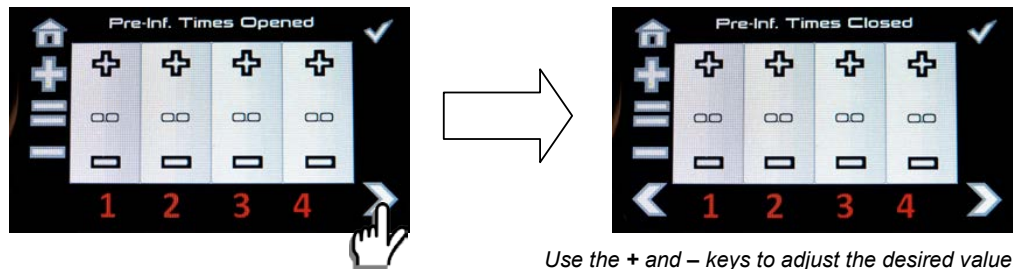

Use the + and - keys to adjust the desired value.
Adjustment range: 0.1sec to 10sec

✓ Press ✓ to Confirm the adjustment to save the settings.



If either of the two settings is adjusted to 0, the pre-infusion mode remains disabled. To enable the Pre-infusion, it is essential that both the times be greater than 0.

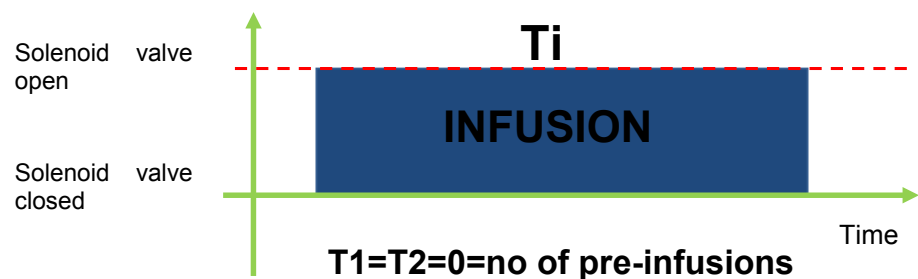
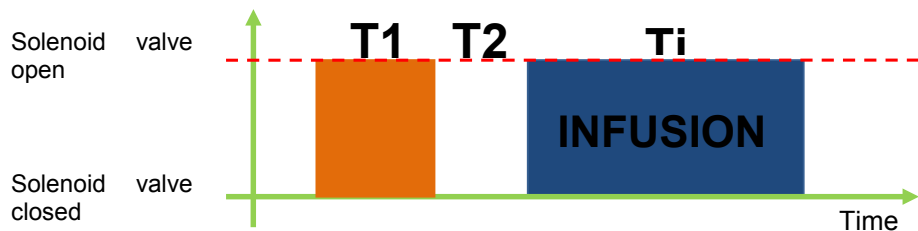

- Self time adjustment (levels 1, 2 and 3)

Only for DOSAMAT machines.

Activating the timer delay makes it possible to place the cups in the SELF mode before the automatic cycle starts.

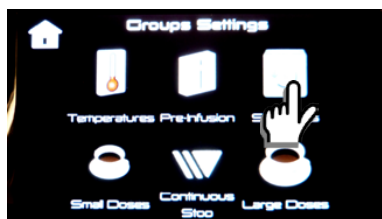

Use the + and – keys to adjust the desired value.

Adjustment range: 0 to 10 sec, default setting, 1 cup: 1.5 seconds

✓ Confirm the adjustment to save the settings.



Switch to 2-cup adjustment

Use the + and – keys to adjust the desired value.

Adjustment range: 0 to 10 sec, default setting, 2 cups: 2.5 seconds

✓ Confirm the adjustment to save the settings.

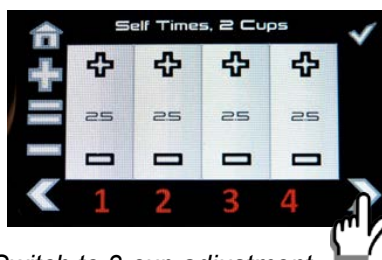

Switch to 3-cup adjustment

Use the + and – keys to adjust the desired value.

Adjustment range: 0 to 10 sec, default setting, 3 cups: 3 seconds

✓ Remember to confirm the adjustment to save the settings.

- **Steam adjustment (level 1, 2 and 3)**

To adjust the steam boiler pressure.

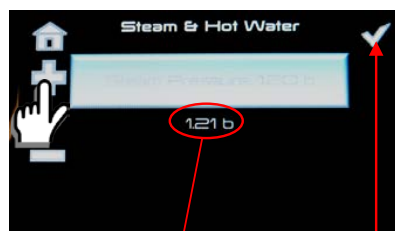
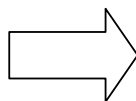

Current steam boiler pressure.

Use the + and – keys to adjust the desired value.

Adjustment range: 0.7Bar to 1.4Bar, default setting 1Bar

✓ Confirm the adjustment to save the settings.

➤ **SteamAir & hot water adjustment (levels 1, 2 and 3)**

To adjust the settings of the **SteamAir** or the hot water control box:

- the temperature at the steam wand probe (*only on machines with SteamAir*)
- the steam timer
- the hot water volumes

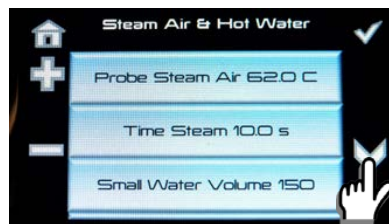
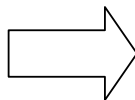

- When you select a line to make an adjustment, it turns pink.
- Use the + and – keys to adjust the desired value.
- ✓ Confirm the adjustment to save the settings.



Adjustment range:

- **SteamAir** sensor: 50°C to 90°C, default setting 62°C
- Steam time: 0 sec to 99 sec, default setting 10 sec
- Small volume of water: 0 to 2,000 ml, default setting 150 ml
- Large volume of water: 0 to 2,000 ml, default setting 300 ml

➤ **Miscellaneous (levels 1, 2 and 3)**

To activate the timer function and assign dose priority to the starting of a cycle: small dose, large dose, last dose used (*Only on DOSAMAT machines*)

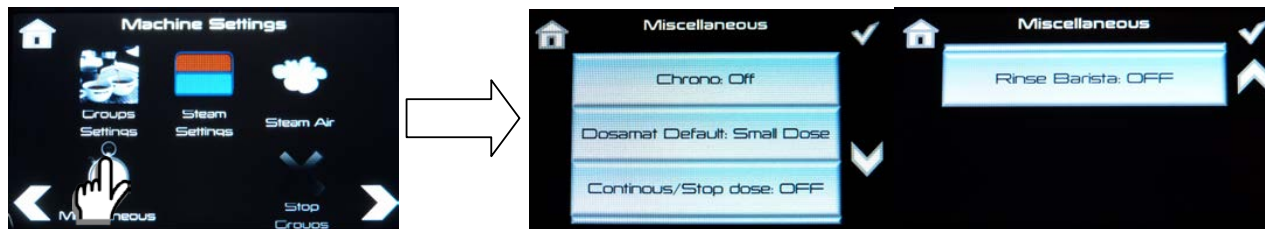

To adjust the timer display on the display of each unit:

CHRONO OFF = Disabled

CHRONO ON = Enabled (visible at the end of the cycle)

CHRONO DYNAMIQUE = Enabled (visible during the cycle)

To adjust dose priority at the start of a cycle:

(Only on DOSAMAT machines)

SMALL DOSE
LARGE DOSE
LAST DOSE USED

E.g.: if "small dose" is programmed, at the end of the cycle (which ever it is) the control box switches back to small dose.

- When you select a line to make an adjustment, it turns pink.
- Press on the line to change the settings
- Confirm the adjustment to save the settings.

! When pre-infusion is activated, the timer displays 2 values at the end of the cycle:

- the first value represents the pre-infusion time in seconds (**T1+T2**)
- the second value represents the total time (pre-infusion + infusion) in seconds (**T1+T2+Ti**)

In the dynamic mode the timer only appears at the end of pre-infusion.

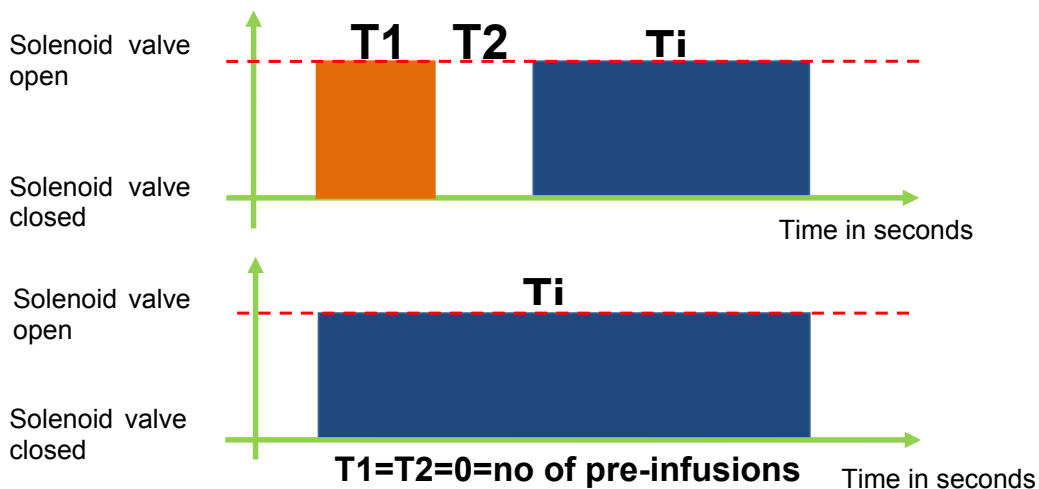

- Continuous/stop cycle key

Existing functions:

1. Stop an infusion in progress
2. Start a continuous cycle (without dosing) manually
3. Extend a dose manually at the end of a cycle.
4. To have a 3^{re} programmable cup volume (volumetric), when the cycle is started with the continuous key.

- I.e 3 new doses in the case of a Dosamat (with filter holder detection).

- a. 1 small cup - 2 small cups - 3 small cups (existing)
- b. 1 large cup - 2 large cups - 3 large cups (existing)
- c. **continuous dose (PF1T) – continuous doses (PF2T) – continuous doses (PF3T)**

-Only one extra dose when there is no Dosamat (refer to CIM)

5. Barista rinsing before the cycle.

Some of these functions are mutually incompatible; the customer should be able to choose the function he wants to use.

The choice of functions on the "continuous" key is common to all groups. If a function is selected, it is applied to all the groups on the machine.

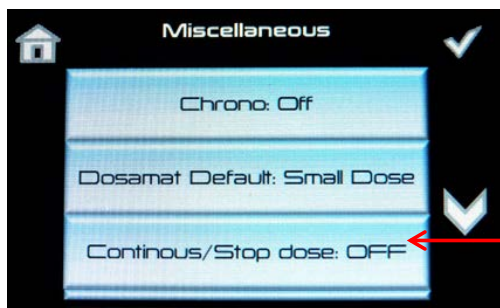

To activate Continuous/Stop dosage

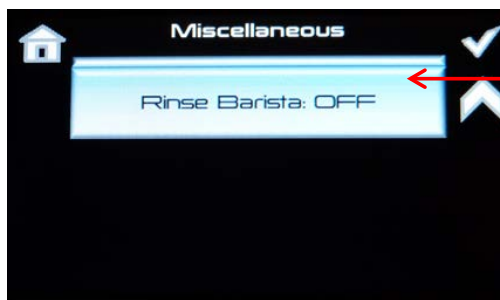

Each time you press the line the value is incremented as follows: OFF ; 1sec ; 2sec ; 3sec ; 4sec ; 5sec ; 6 sec ; OFF ; 1sec ; 2sec ; etc...

OFF= function de-activated

Xsec = the Barista rinsing cycle will have a duration of Xsec

- For a machine with the Dosamat system, functions 4 (3rd dose) and 5 (Barista rinsing) will be compatible.

The distinction will be made by the presence of the filter holder: With the filter holder engaged = 3rd dose / without filter holder = Barista rinsing.

Function 4 = 3rd dose: "Continuous key = 3rd dose"

- If its function is not enabled in "miscellaneous", the "continuous" key will operate according to its normal functions (**Function 1, 2 and 3**).
- If the function: "**continuous/stop**" dose is activated, when a cycle is started directly by the continuous key, it becomes the additional "continuous/stop" dose in the same way as small or large cup.
- Programming is done in the same way as the other doses in the "group adjustment" menu: The corresponding "continuous/stop" icon is added.
- The cycle runs as a normal cycle (with or without pre-infusion).

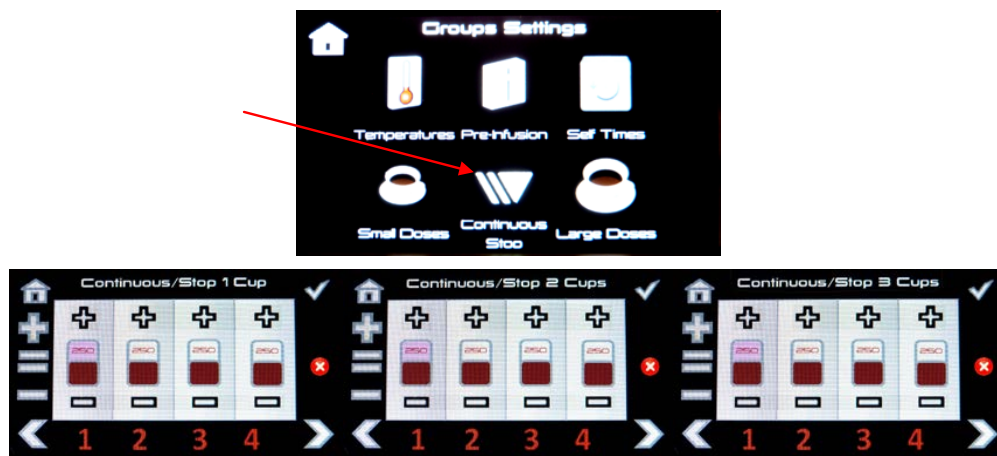

Function 5 = Barista rinsing:

This function is requested by the barista who is used to rinsing the group (water flow for a few seconds) just before closing the filter holder to make the infusion.

- In the Dosamat version, the barista removes the filter holder and presses the "continuous" key: the coffee solenoid valve and the pump start operating for the programmed time.
- In the Non-Dosamat version, if the function is confirmed the "continuous/stop" cycle will last for the programmed time.

In this case pre-infusion is deleted on the continuous/stop key, but retained on the "normal cycles" keys.

Similarly, if we press the "continuous" key at the end of the cycle without removing the filter holder, we find ourselves in the normal function 3 (without dosing).

- On a machine without the Dosamat system, (according to the CIM board indication) the customer will need to choose the function that he wishes to use, the others will be disabled.

If the "Barista rinsing" function is confirmed, the "continuous" time (functions 2 and 3) will be limited to the programmed time for "Barista rinsing" (1 to 6sec) instead of the usual safety system.

In all events:

- The "continuous" key can stop a cycle that is running at any time, and should remain lighted during cycles, and also can be used at the end of the cycle to allow the dose to be extended.
- The 150 second safety limit is also maintained.
- Any programmed "continuous" functions apply to the whole of the machine (all the groups).
- The "continuous/stop" dose should be included in the timers
- In the event of a "credit-debit" or "debit-credit" computer connection the continuous/stop key only serves to stop the cycle, as currently.

▪ Counter

- To count the drinks prepared from 1, 2, 3 or 4 BGX control boxes in the configuration: DM, 2cups, 3cups, or on/off (including continuous/stop).
- To meter the "hot water" and "**SteamAir** steam".
- Enables reading of the various meters independently with defined access and reset authorisations.

List of counters available:

6 groups of counters are provided each containing the following counters:

- TOTAL Small + large "coffees" + continuous/stop
(The sum of all the groups) + TOTAL per group
- TOTAL Small "coffee" (the sum of all the groups)
+ TOTAL Small "coffee" per group
- TOTAL Large "coffee" (the sum of all the groups)
+ TOTAL large "coffee" per group
- Continuous/stop or 3rd dose
- SteamAir** steam
- Hot water

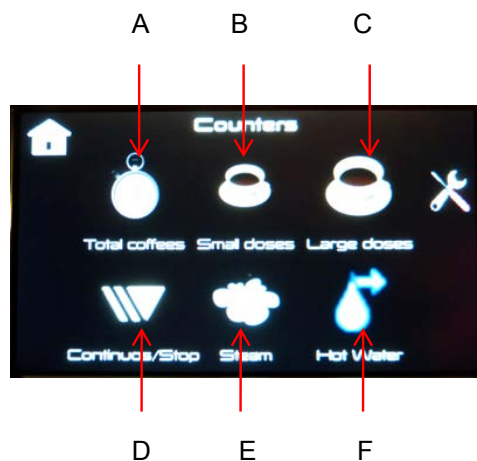

Definition of accesses for reading and resetting:

- * Level 0→ Reading of USER counters (if authorised by level 2 or USB level)
- * Level 1 and 2→ Reading of all USER counters and resetting only of small and large coffee counting (total and partial)
- * Level 3→ Reading and resetting of all USER counters.
- * USB level→ Reading and resetting of USER counters, reading of "machine maintenance" counters.

It is not possible to reset the "machine maintenance" counters (except in special cases).

Counter settings (access via level 3 and USB level)

(Level 0 and level 1 and 2, the icon is not visible)



- **Counter visible level 0 (YES / NO):** to display or mask the reading of counters in level 0.
- **Reset of all counters:** Serves to reset all counters in a single operation (total reset of small doses, total reset of large doses, total reset of continuous/stop, total reset of steam, total reset of water doses).
- **Enable counters YES/NO):** serves to lock out all counters temporarily.

Counter display:

A-TOTAL Small + large "coffees"

View or reset the total counter

View or reset the partial counter

Indication of the number of drinks produced since the last inspection

View or reset the each unit total counter

Reset of counters (level 3 and USB level only):

When consulting counters by level 3 or USB level the RAZ indication appears on the total counter line and the partial counter line; this indicates that it is possible to reset the counters.

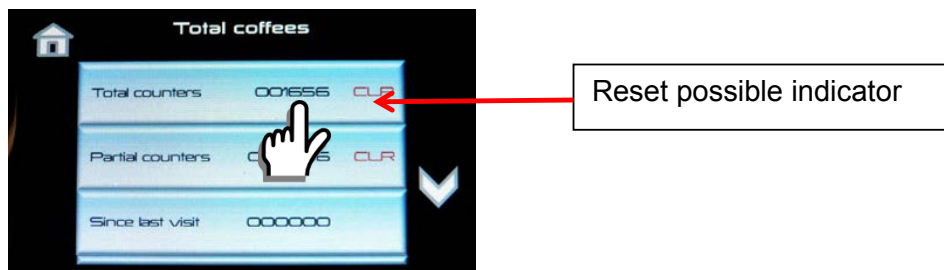

The reset is performed by pressing the line

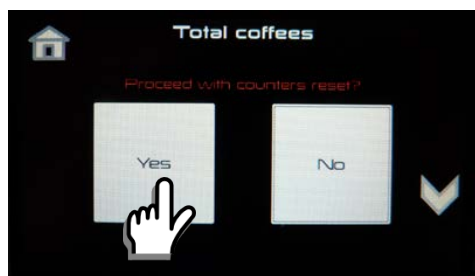

To confirm the reset press YES twice

Important:

- When the total is reset (1st line), the partial counter and the group counters are reset.
- When the partial counter is reset (2nd line), only the partial counter is reset

Counter:	ACTION	Total reset	Partial reset	Total per group
A- Small + large "coffees" + continuous	TOTAL reset	x	x	x
B-Small "coffee"		x	x	x
C-Large "coffee"		x	x	x
CD-Continuous/stop		x	x	x

X=Counter reset

Counter:	ACTION	Total reset	Partial reset	Total per group
A- Small + large "coffees" + continuous				
B-Small "coffee"	TOTAL reset	x	x	x
C-large "coffee"				
D-Continuous/stop				

Counter:	ACTION	Total reset	Partial reset	Total per group
A- Small + large "coffees" + continuous				
B-Small "coffee"				
C-large "coffee"	TOTAL reset	x	x	x
D-Continuous/stop				

Counter:	ACTION	Total reset	Partial reset	Total per group
A- Small + large "coffees" + continuous				
B-Small "coffee"				
C-large "coffee"				
D-Continuous/stop	TOTAL reset	x	x	x

In all events:

- If there is a reset of a partial counter, the total per group is not reset.
- The, E-Steam **SteamAir**, F-Hot water counters count separately, they have no effect on the coffee counters.

Operation of the "since the last inspection" counter (3rd line)





This counter is simply an indication for the user; it enables him to view the number of drinks that have been produced since the last inspection of the counter.

This function is present in the 6 counters (A-B-C-D-E-F)

8. USE

➤ Dosamat control box (part number 45100)







- The figures **1** **2** **3** correspond to the filter holder engaged (1, 2 cups or 3 cups)
- The   keys correspond respectively to the selection: (small dose) **c**, or (large dose) **C**.
- The  key selects the manual mode: Manual cycle start.
- The  key selects the Self mode: Automatic start of the cycle corresponding to the filter holder engaged.
- The continuous/stop  key enables us to stop a cycle in progress or start a continuous cycle (not dosed), except if the stop/continuous function is activated.

A brief pressure at the end of the cycle also triggers the display of the infusion time of the cycle if the time function has been activated, except during the pre-infusion time.

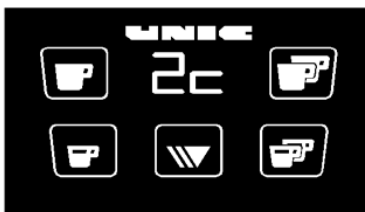
Note: it is possible to change from a small to a large cup during a cycle, and vice versa, in this case, if the change from large to small dose is performed when the dose has already been exceeded, the cycle stops.

➤ 2-cup control box (4-dose part number: 45102)







- The   keys correspond respectively to **1c** (1 small dose) and **2c** (2 small doses)
- The   keys correspond respectively to **1C** (1 large dose) and **2C** (2 large doses)

- The continuous/stop  key can be used:
 - to stop a cycle in progress
 - to start a continuous cycle (not dosed)
 - A brief pressure at the end of the cycle also triggers the display of the infusion time if the time function has been activated, except during the pre-infusion time.

Note: it is possible to change from a small to a large cup during a cycle, and vice versa, in this case, if the change from large to small dose is performed when the dose has already been exceeded, the cycle stops.

➤ 3-cup control box (6-dose part number: 45103)



- The    keys correspond respectively to the figures **1** **2** **3** (1 dose, 2 doses, 3 doses)
- The  key serves for the selection of a small dose **C**, or large dose **C**.
- The continuous/stop  key can be used:
 - to stop a cycle in progress
 - to start a continuous cycle (not dosed)
 - A brief pressure at the end of the cycle also triggers the display of the infusion time if the time function has been activated, except during the pre-infusion time.

Note: it is possible to change from a small to a large cup during a cycle, and vice versa, in this case, if the change from large to small dose is performed when the dose has already been exceeded, the cycle stops.

➤ **Manual control box (ON/OFF part number: 45101)**



- The display shows the infusion time



Cycle start



Cycle stop

➤ **SteamAir control box (part number 45104)**



- The display shows the volume of the water dose, the steam timer or displays the actual temperature of the **SteamAir** sensor, depending on the cycle in progress.
- In the event of simultaneous cycles, the **SteamAir** temperature display has priority.



- The  keys correspond respectively to the programmed small and large water doses.



- The  key corresponds to the timed steam.



- The  key corresponds to the **SteamAir** mode (the cycle stops automatically when the sensor reaches the programmed temperature).





- The continuous/stop  key can be used to stop a cycle in progress.

➤ Hot water/manual tap control box (part no 45105)



- The display shows the progress of the programmed water dose

- The   keys correspond respectively to the programmed small and large water doses.

- The  key stops the cycle in progress and enables a continuous non-dosed cycle to be started.

Note: it is possible to change from a small to a large dose during a cycle, and vice versa, in this case, if the change from large to small dose is performed when the small dose has already been exceeded, the cycle stops.

➤ SteamAir Option

Press the  key and stop to purge the **SteamAir** outlet.

When the air/steam adjustment is determined, the operation consists of:

- Insert the **SteamAir** spout into the milk container.
(Do not fill with too much milk to avoid the foam overflowing)
- Press the **SteamAir** key 
- Wait for the automatic stop.

The **SteamAir** control box also controls time controlled hot water and steam outlets.

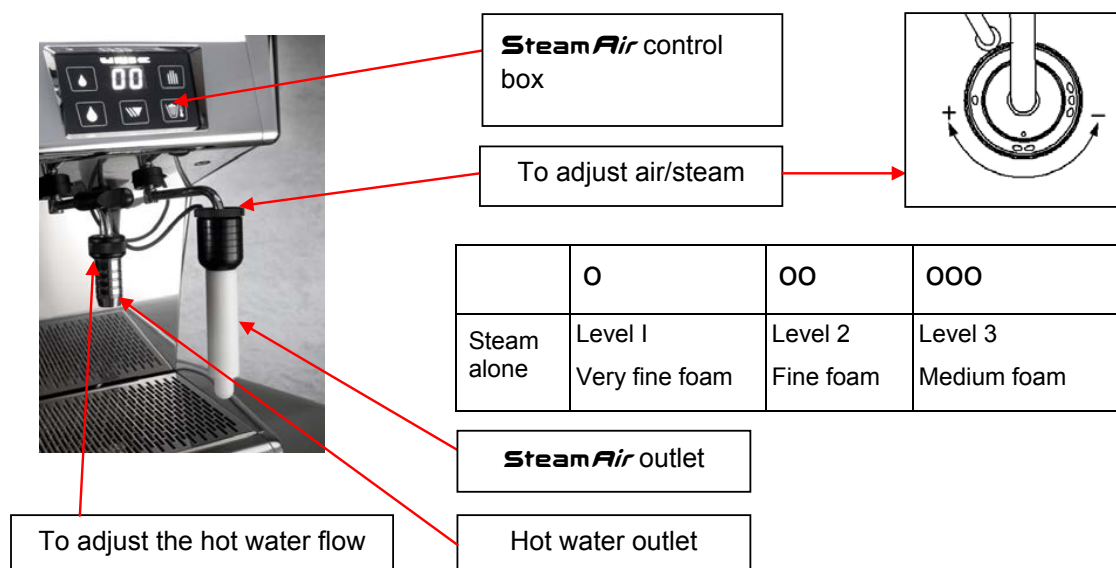

➤ Dual Control Option (DCL)

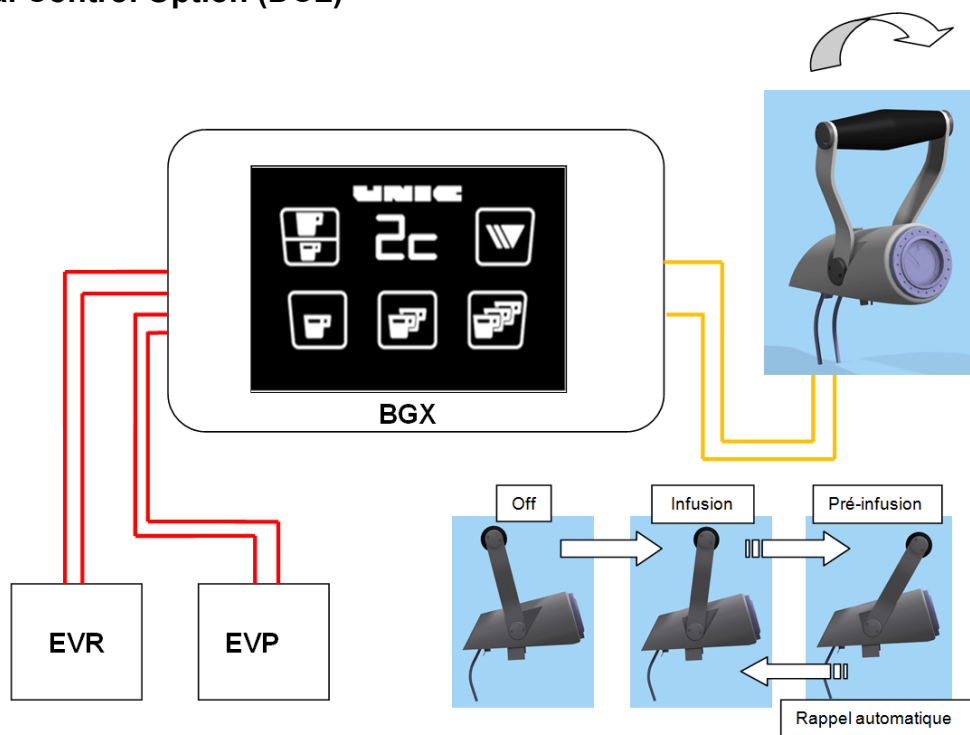

- Serves to control infusion and pre-infusion manually
- The group control box remains fully operational.
- A pressure gauge indicates the instant pressure in the group's pre-infusion chamber
- When the dual control in use the keyboard is disabled and vice versa
- The system is fitted with a detent enabling the engagement of the pre-infusion solenoid valve to be felt on the handle

Keyboard compatible with the dual control system



Note: The dual control system will not be available with Dosamat 45100 control boxes

9. CLEANING AND MAINTENANCE

➤ After every use

Steam outlet pipe:

After every use, clean the steam outlet pipe with a damp cloth and blow steam out briefly to remove milk residue from the inside of the pipe

➤ Daily

▪ Semi-automatic cleaning

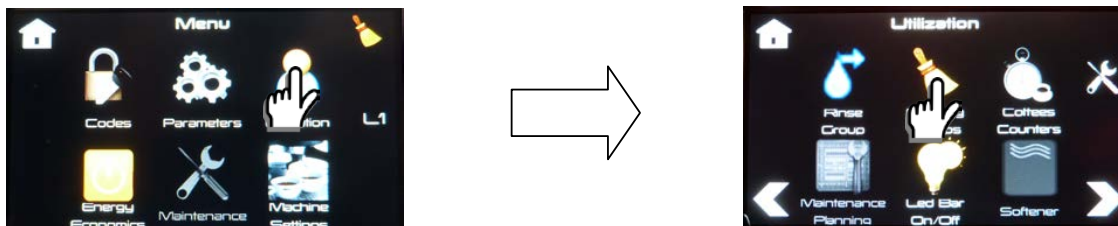

Important:

Groups that are not selected function normally.

The keys for the selected groups are illuminated in blue, all the keys are enabled

Step 1

The BTA indicates:

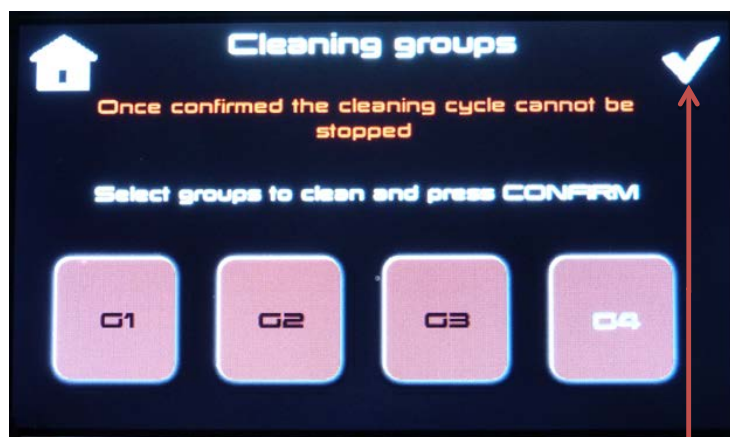

- Once the groups have been selected, confirm to start the cleaning cycle.

Step 2

The BTA indicates:

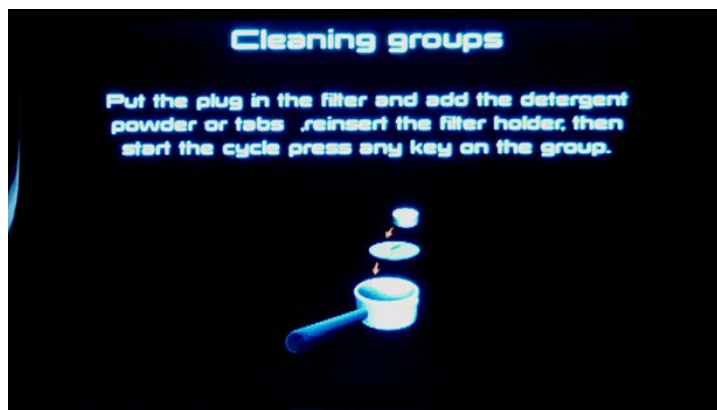

Description of the cleaning cycle:

- Sequences of **8 seconds** ON and **12 seconds** OFF (EVX+PUMP)
- Numbers of sequences: **15** (les BGX indiquent le nombre de cycles restants)

During the cleaning cycle:		
Phase	Display	Key
Selection of groups on the BTA	"Gn" on the groups selected	Disabled, steady blue on the control boxes of the groups selected and on the strip
Cleaning ready	"nr" "Cleaning ready"	Enabled, steady blue
Cleaning in progress	Cycles remaining	Disabled, flashing blue
End of cleaning	"nC" "Cleaning finished"	Disabled, steady blue

Step 3

The BTA indicates:

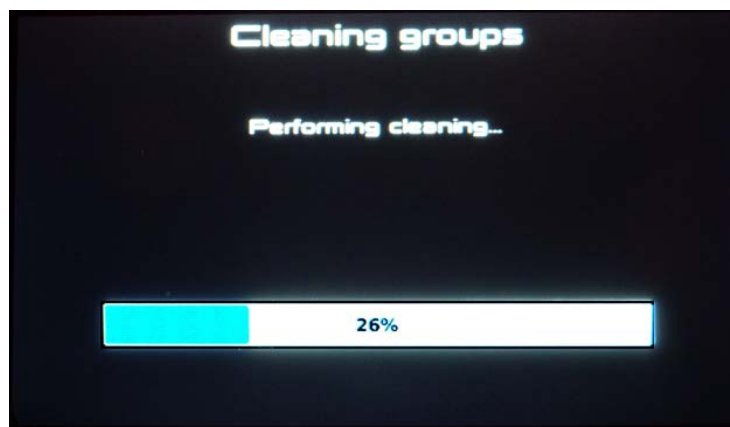

- The progress bar (blue) increases every 30sec
- The progress bar display is controlled by the last group started.
- At the end of the cleaning cycle, the control boxes and the luminous strip above the control boxes are illuminated steady blue.

Step 4

The BTA indicates:

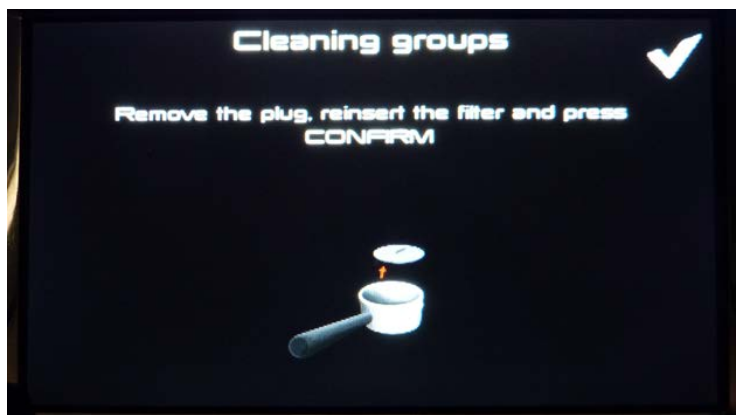

- Semi-automatic rinsing

Description of the rinsing cycle:

(EVX+PUMP) = ON for 45 seconds.

- When the rinsing cycle is ready to be started, the BTA indicates:

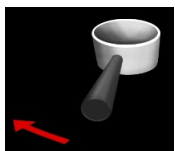
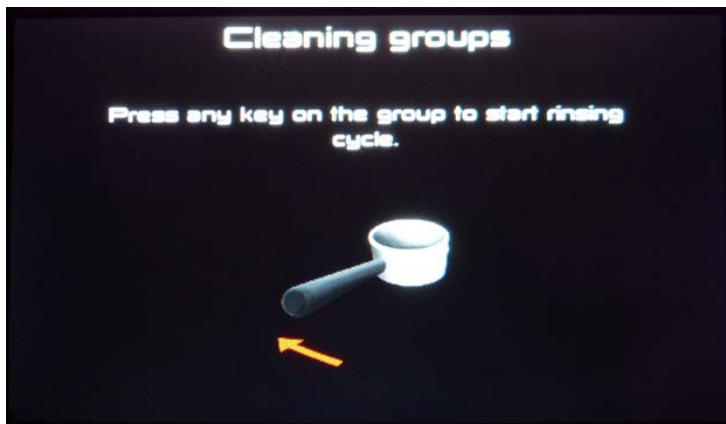

- Press any key to start the rinsing cycle and move the cup as shown.

Description of the cycle end:

Step 5

The BTA indicates:

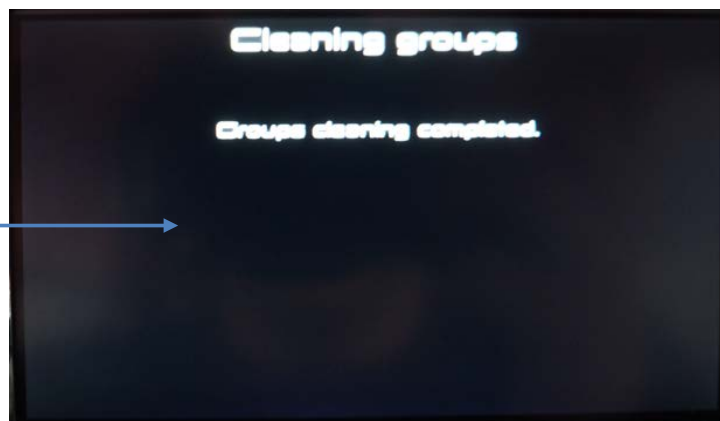

The BGX control boxes are blue for 2 seconds and then return to display and normal operation.

The BTA displays the message above for 5 seconds and then returns to normal display

Important:

- Once the groups have been selected and confirmed (step 2) it is no longer possible to exit from the cleaning mode, the home key disappears.
- The dosamat is disabled.
- If there is a power cut during the cycle, the cycle should restart automatically after the machine has restarted, at the point where it was previously.
- Once the cleaning cycle is started (step 2) it is no longer possible to stop it, the group keys are disabled.
- The display of step 3 is triggered by the end of the last cycle.
- The display of step 4 is triggered by the end of the last cycle.

During the rinsing cycle:		
Phase	Display	Key
Rinsing ready	"nr" "Rinsing ready"	Enabled, steady blue on the control boxes of the groups selected and on the strip
Rinsing in progress	Time remaining (seconds)	Disabled, flashing blue
Rinsing complete	"nr" "Rinsing complete"	Disabled, steady blue

➤ Weekly

In addition to daily cleaning:

Portafilter:

Remove the filter basket and clean the cup and basket with soapy water.

Overflow tray:

Remove the top of the ball and clean it underwater.

➤ Front panel cleaning

The front panel cleaning mode disables all the touch keys to allow them to be cleaned.

Press the broom-shaped icon until the control boxes display "nC".

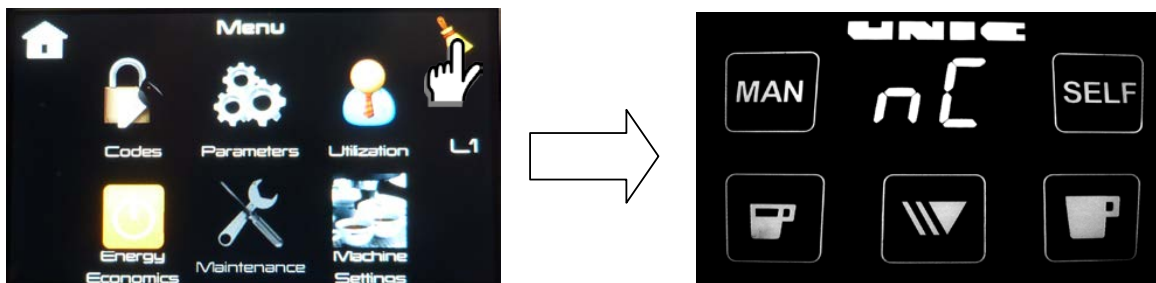

When the control boxes display "nC" all the keyboards are disabled.

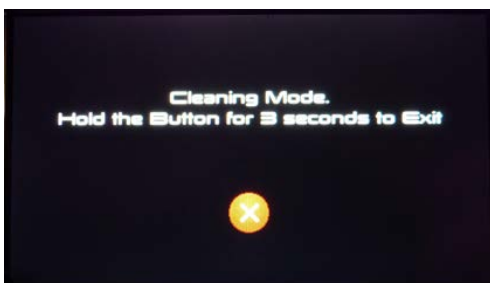

Press the red cross **for 3 seconds** to disable the cleaning mode and return to the normal mode.



Never clean the glass faceplates or screens with abrasive products or chemicals.

Use cold water and a microfibre cloth to clean the front panels.

➤ Cleaning the *SteamAir* outlet

Remove and clean the outlet at least once per day

After every use, rinse the outlet by blowing steam out



BEFORE 2012

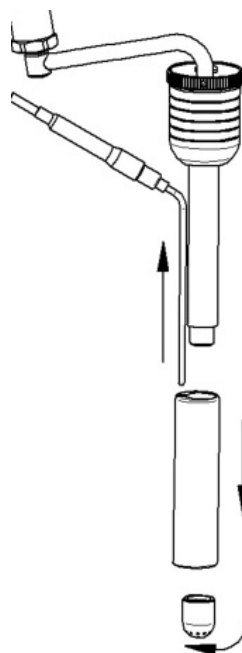

AFTER 2012

➤ Others

Use a soft cloth and alcohol to clean the stainless steel parts and nonabrasive cleaner for the painted parts of the machine.

To prevent scale formation remember to renew your water softener regularly.

If descaling is necessary, the machine should be given to the manufacturer's repairer or a person with similar qualifications.

10. MAINTENANCE AND REPAIRS

➤ Update procedures

During an update you should:

- If possible save the machine settings on the **machine USB dongle** (Maintenance → data transfer → settings export)
- Perform an update of the CPU with a **USB+ dongle**
- Import the CIM configuration from **the machine USB dongle** (Maintenance → data transfer → CIM import) or reconfigure the machine using CIM creator
- Import the machine configuration (Maintenance → data transfer → settings import)

▪ BTA update

- Start the machine and wait for the end of the BTA starting cycle
- At the end of the starting cycle insert the **USB + dongle**
- The hourglass pointer appears, followed by the update screen
- Uncheck "**Calib**" to stop the countdown and then check "**BTA**" and press "**upgrade**"

 If you do not uncheck "**Calib**", the calibration procedure starts at the end of the countdown.
See *BTA calibration procedure*

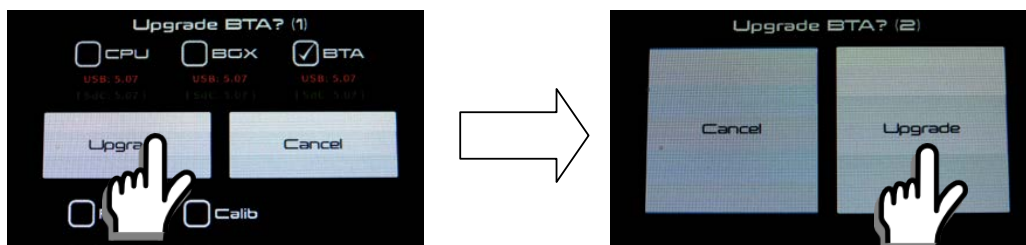

- Confirm "**upgrade**"
- *The control box will restart automatically. The progress of the update is not visible.*
- *Note: During an update the restarting of the control box takes longer, **DON'T SWITCH THE MACHINE OFF***
- Wait for the end of the starting cycle
- When the screen background reappears, the BTA is updated with the time and date.

▪ CPU update

 **If you have not exported the CIM and the settings, they will be lost and will need to be reconfigured.**

- Proceed in the same way as for the BTA
- check "**CPU**" and press "**upgrade**"

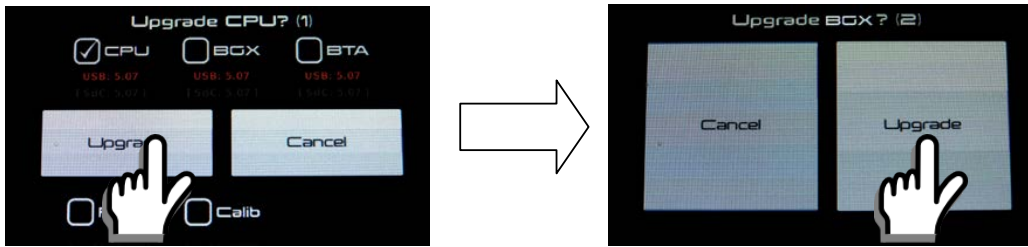

- Press "upgrade" a second time
- The BTA displays the evolution of the update and the status of each control box. The colour orange shows that the update is in progress, the colour green confirms success of the update, and red indicates that the update has failed.
- At the end of the update remove the USB dongle and restart the machine

⚠ After an update of the CPU you need to reconfigure the CIM of the machine see CIM setting heading.

➤ **BGX/BST update**

- Proceed in the same way as for the BTA and the CPU
- Check "BGX" and press "upgrade" (CPU is selected automatically)

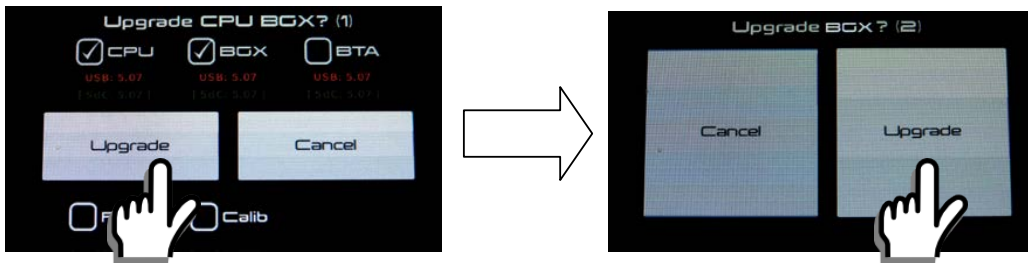

- Press the "upgrade" button a second time

The updating process is started: the control boxes will be updated one after the other.

The BTA displays the evolution of the update and the status of each control box. The colour orange shows that the update is in progress, the colour green confirms success of the update, and red indicates that the update has failed.

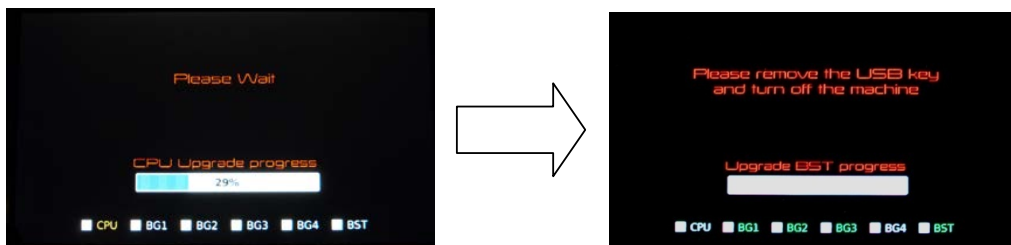

IMPORTANT: At the end of the update remove the USB dongle and restart the machine

➤ Assignment of one or more BGX/BST control boxes

If a mistake is made when assigning one or more control boxes it is possible to re-launch the assignment process.

- Start the machine and wait for the end of the BTA starting cycle
- At the end of the starting cycle insert the **USB + dongle**
- The hourglass pointer appears, followed by the improvement screen
- Uncheck "Calib" to stop the countdown and then check "Reset" and press "upgrade"

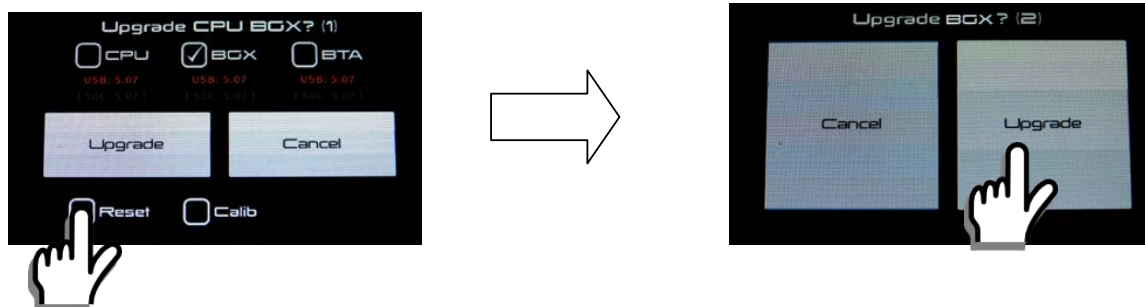

The control boxes flash green while awaiting the assignment of their positions



1°: G1 flashes, press SELF to confirm your choice



2°: G1 stops flashing, your choice is confirmed



1°: G1 flashes, press MAN to change assignment

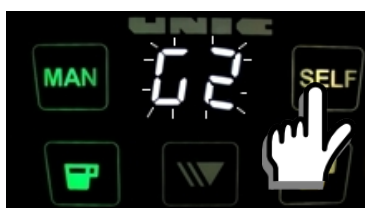

2°: G2 flashes, press SELF to confirm your choice



3°: G2 stops flashing, your choice is confirmed



1°: ST flashes, press steam touch to confirm your choice



2°: ST stops flashing, your choice is confirmed

➤ **Using CIM-creator**

This can be used to configure the equipment such as control boxes and various outputs.

Prerequisite: to use CIM-creator you need to possess a machine updated with a **BTA V2** and a **USB + dongle**

- Insert the USB+ dongle



Click on cancel

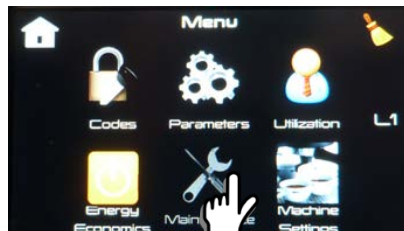

Click on maintenance

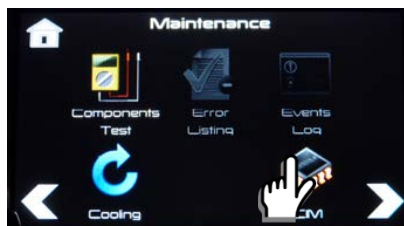

Click on CIM

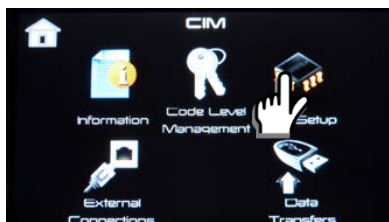

Click on CIM settings



You are now in CIM Creator

Configuration of the groups

Steam outlet type

Type of pre-infusion

Temperature offset

Configuration of the groups:	Type of steam outlet:	Type of pre-infusion:
<ul style="list-style-type: none"> DM = Dosamat 3cups = 6-dose control boxes 2cups = 4-dose control box ON/OFF = manual control box ST = SteamAir control box HW = hot water control box ... = no group or no control box 	<ul style="list-style-type: none"> EV = Easyglide steam valve solenoid valve EV+ SteamAir = solenoid valve + SteamAir sensor Manual = Easyglide steam valve 	<ul style="list-style-type: none"> EVX time = timer-controlled coffee solenoid valve EVX + EPX time = timer-controlled pre-infusion solenoid valve EVPX + Cpress = pressure sensor-controlled pre-infusion solenoid valve

Standard type settings:

The image displays four screenshots of the 'CIM Edit' menu, arranged in a 2x2 grid. Each screenshot shows a 'Groups Modes Configuration' screen with buttons for BC1, BC2, BC3, BC4, and BST. Below these are buttons for 'DM', 'OM', and 'ST'. Further down are 'Steam Mode' (EV+SteamAir), 'Temp. Offset' (8), and 'Pranf. Type' (EVX+EPX Time). A red box with the text 'Don't check the DC boxes (unless option DCL)' is positioned between the top and bottom rows. Red arrows point from this box to the 'DC' buttons in the top-right and bottom-left screenshots.

Top Left Screenshot: 2 units SDC with **Dosamat (DM)** box And **SteamAir (ST)** box

Top Right Screenshot: 3 units SDC with **6 doses (3cups)** And **hot water (HW)** box

Bottom Left Screenshot: 3 units SDC with **manuals (ON/OFF)** box And **Hot water (HW)**

Bottom Right Screenshot: 3 units SDC with **4 doses (2cups)** box And **hot water (HW)** box

➤ Diagrams

- BGX control box connections

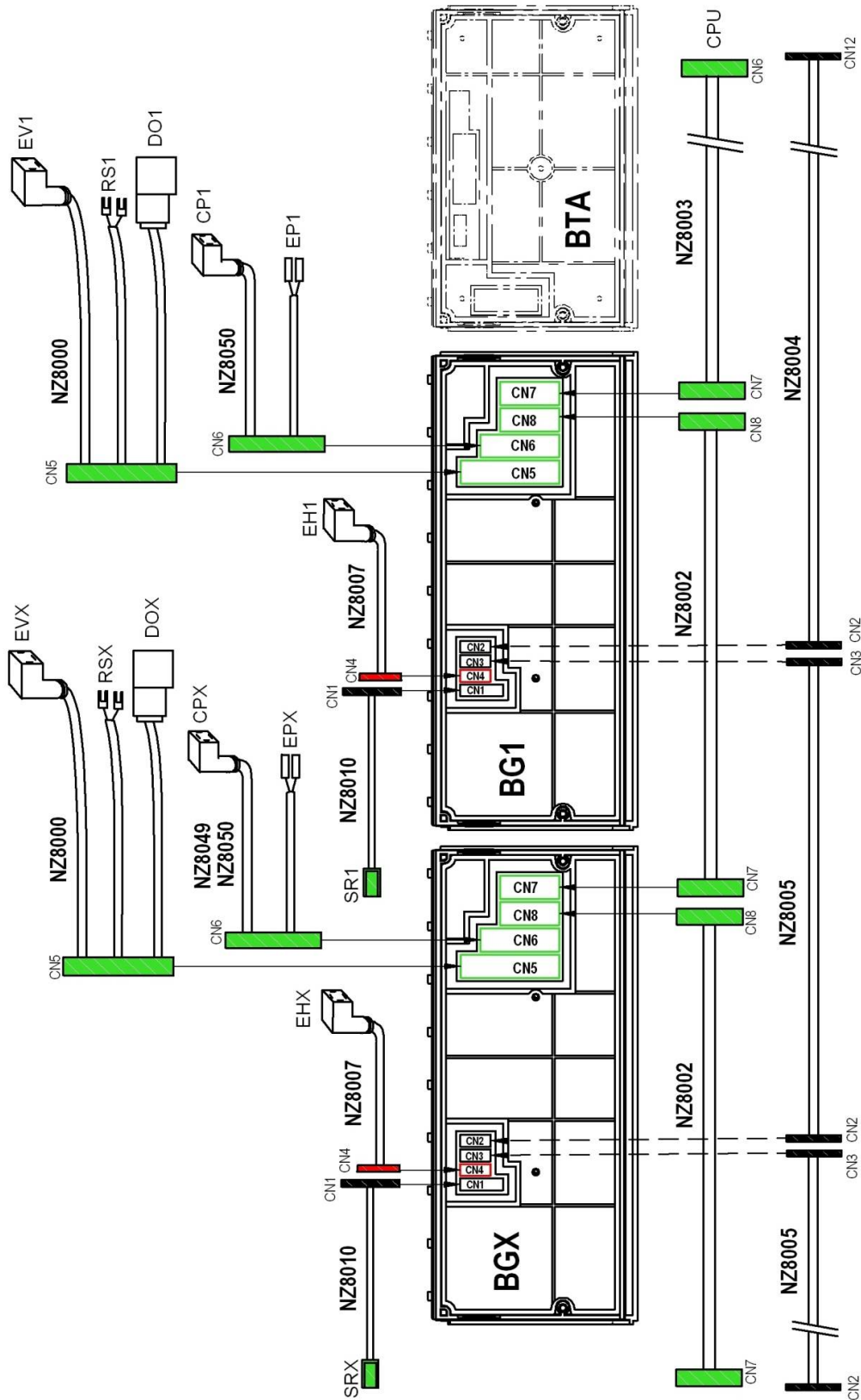

▪ BTA & BST control box connections

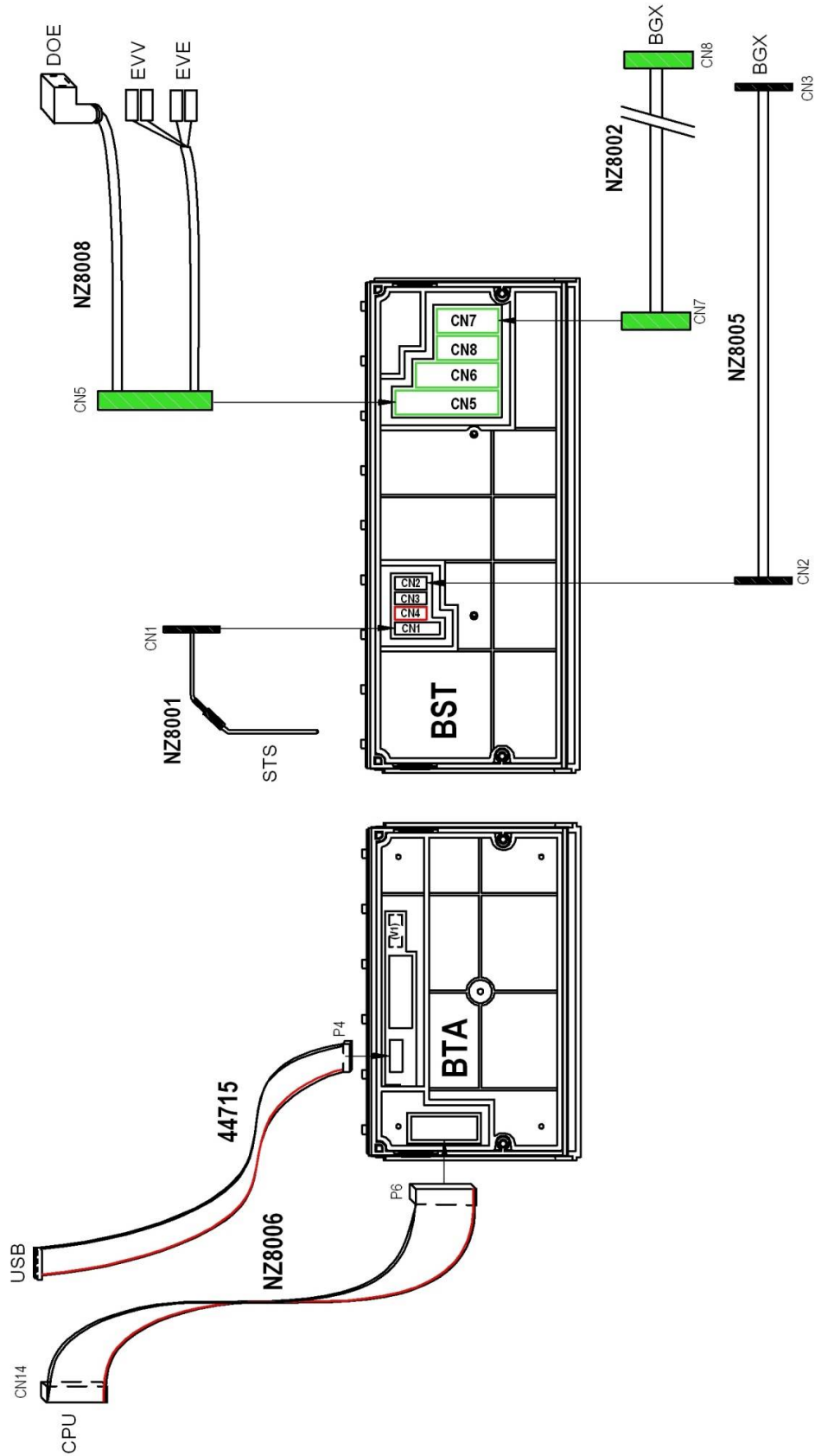

▪ CPU board connections

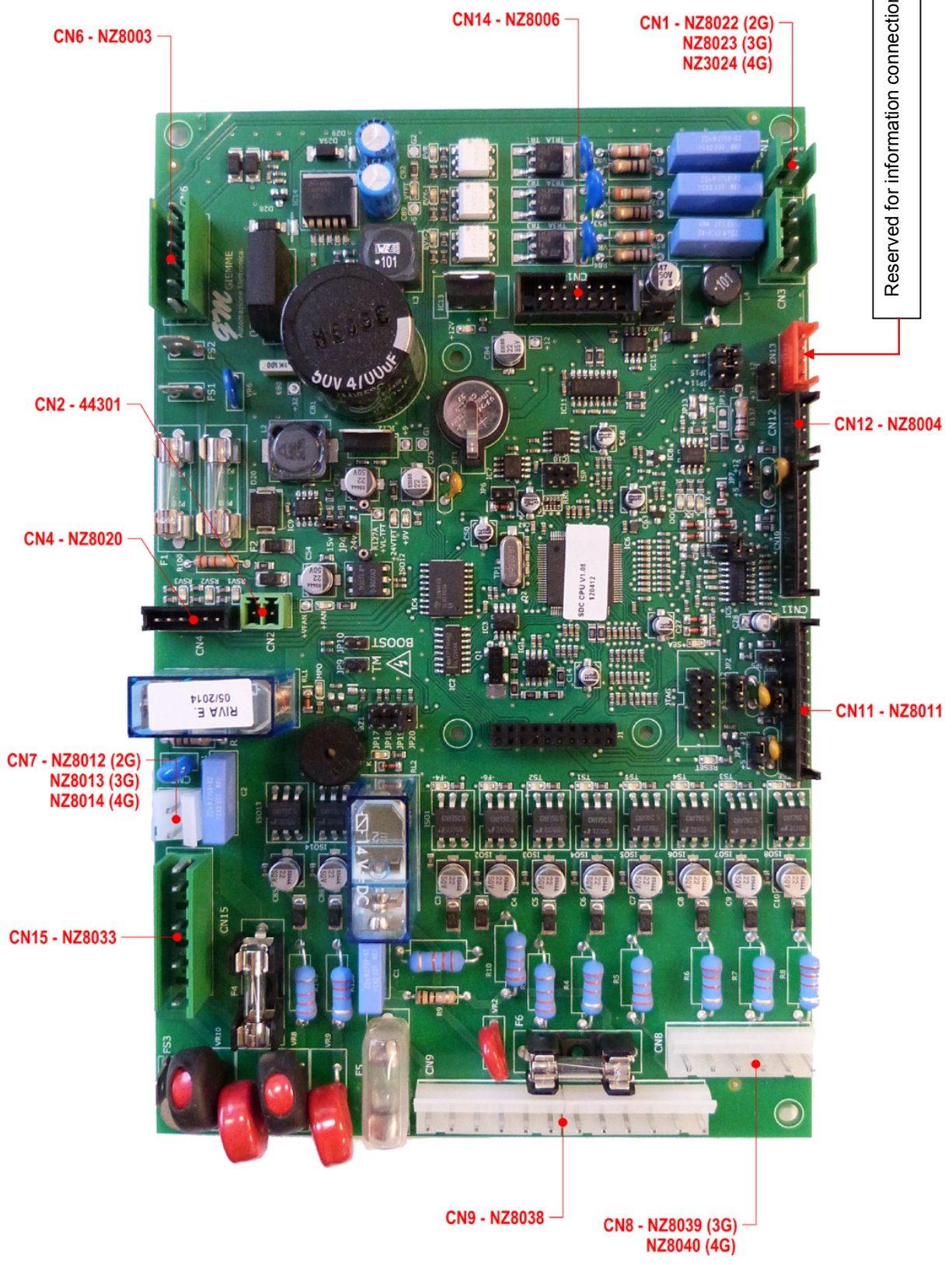

- Lights and straps

JUMPER	DESIGNATION	DESCRIPTION
JP1	Alimentation pressostat CPR +12V/+5V	CPR pressure switch supply +12V / +5V
JP2	Alimentation pressostat STV +12V/+5V	STV pressure switch supply +12V / +5V
JP3	Préparation capteur STV NTC/pressostat	STV NTC / pressure switch sensor preparation
JP4	Alimentation rétroéclairage TFT 24V/15V	TFT backlight supply 24V / 15V
JP5	N.U.	N.U.
JP6	N.U.	N.U.
JP7	Alimentation capteur humidité CHU +12V/+5V	CHU humidity sensor supply +12V / +5V
JP8	Alimentation série RS232 CN13 32V/12V	RS232 CN13 serial 32V / 12V supply
JP9	Choix mono/ triphasé (pas avec V10 ou antérieur)	Mono / 3-phase choice (not with V10 or before)
JP10	Activation BOOST (pas avec V10 ou antérieur)	BOOST activation (not with V10 or before)
JP11	N.U.	N.U.
JP12	Terminal 485 inséré	Terminal 485 inserted
JP15-JP16	RS485 active	RS485 enabled
JP17	N.U.	N.U.
JP18	N.U.	N.U.
JP19	Insérer à l'allumage RESET DEFAULT	Insert on switching on FAULT RESET
JP20	Insérer DEMO MODE	Insert in DEMO MODE
LED	DESIGNATION	DESCRIPTION
SEA	Pressure switch présence H2O	H2O presence pressure switch
DOG	Compteur volumétrique général	General volumetric meter
K	Contacteur général	Main switch
MPO	Relais moteur pompe	Pump motor relay
F4	Présence fusible F4	Fuse F4 presence
F6	Présence fusible F6	Fuse F6 presence
TSV	Thermostat de sécurité chaudière	Boiler safety thermostat
TSE	Thermostat de sécurité chaudière externe	External boiler safety thermostat
TS1	Thermostat de sécurité groupe 1	Safety thermostat group 1
TS2	Thermostat de sécurité groupe 2	Safety thermostat group 2
TS3	Thermostat de sécurité groupe 3	Safety thermostat group 3
TS4	Thermostat de sécurité groupe 4	Safety thermostat group 4
EVX-2	Électrovanne Aux. 2	Auxiliary solenoid valve 2
EVX-1	Électrovanne Aux. 1	Auxiliary solenoid valve 2
EVR	Électrovanne remplissage chaudière	Boiler filling solenoid valve
+9V	Régulateur 9V	9V regulator
+12V	Régulateur 12V	12V regulator
VTFT	Régulateur commutation 5V pour TFT	5V switching regulator for TFT
+24VTFT	Alimentation rétro-éclairage écran TFT	TFT screen backlight supply
RX	Signal réception RS485	Signal reception RS485
TX	Signal transmission RS485	Signal transmission RS485
RSV1	Résistance 1 chaudière	Boiler heating element 1
RSV2	Résistance 2 chaudière	Boiler heating element 2
RSV3	Résistance 3 chaudière	Boiler heating element 3
RESET	ON si carte on fonction	ON when board operating

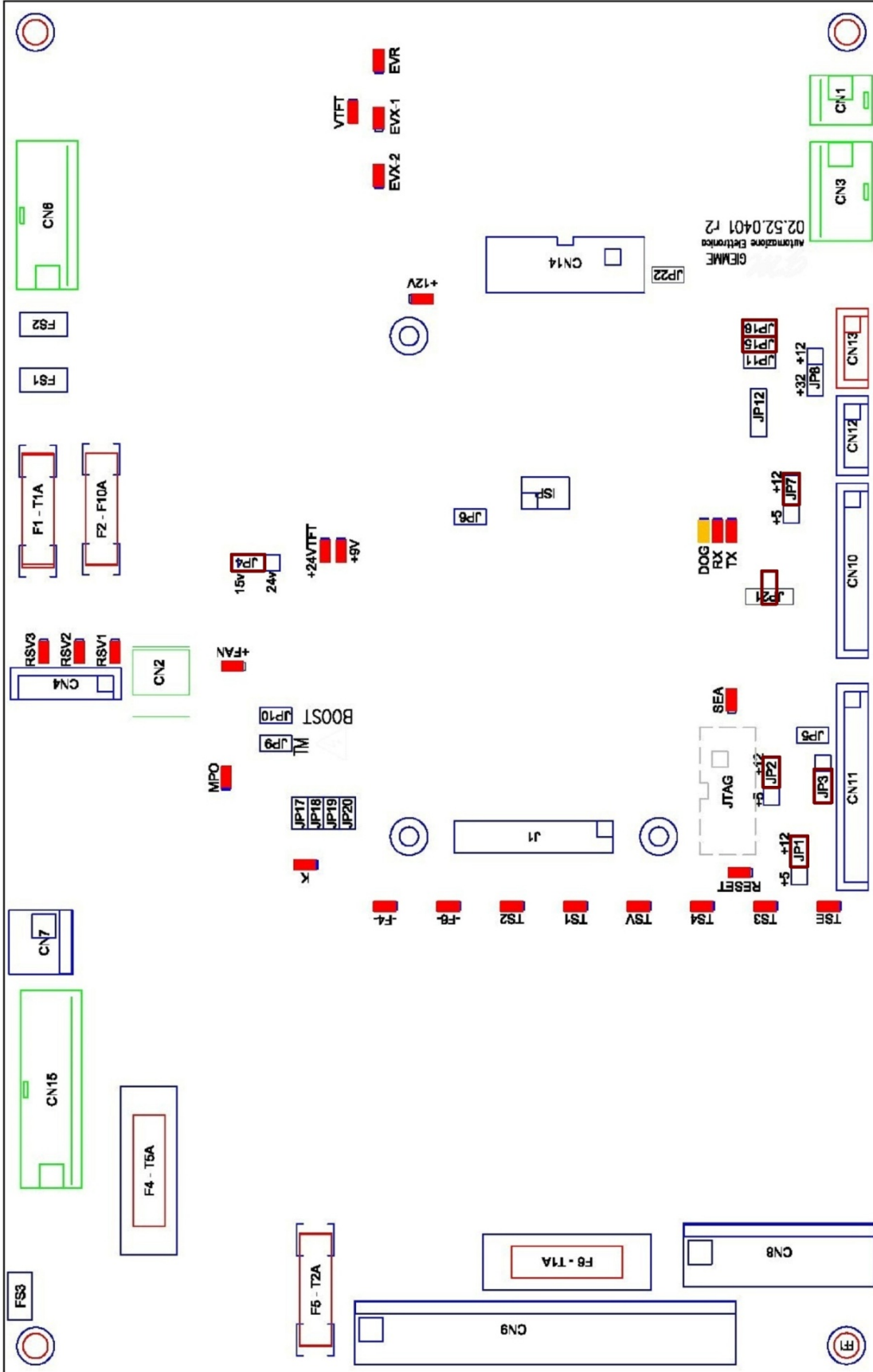

- Hydraulic diagram

E.g. Stella 3GR diagram

1	ID-75	TUBE FLEXIBLE COUDE ARNE INOX	FLEXIBLE PIPE
2	NZ6015	TUBE EVACUATION SOUPAPE HP	HP VALVE DRAIN TUBE
	NZ6016	TUBE EVACUATION SOUPAPE HP (V+)	HP VALVE DRAIN TUBE (V+)
3	NZ6011	TUBE REMPLISSAGE CHAUDIERE	BOILER FEEDING PIPE
4	NZ6008	RAMPE DOSEUR ET ENTREE EAU	WATER FEEDING & DOSER PIPE
5	NZ6007	RAMPE DOSEUR EAU	WATER DOSER PIPE
6	NZ6012	TUBE CAPTEUR RESEAU	NETWORK SENSOR PIPE
7	NZ6006	TUBE ALIMENTATION GROUPE	GROUP FEED PIPE
7	NZ6018	TUBE ALIM. GROUP PRE INFUSION	PRE-INFUSION GROUP FEED PIPE
8	NZ6013	TUBE CAPTEUR VAPEUR	STEAM SENSOR PIPE
9	NZ6010	TUBE ROBINET VAPEUR	STEAM TAP PIPE
10	25902	SORTIE VAPEUR STELLA INOX	STELLA S/S STEAM OUTLET
10	25903	SORTIE VAPEUR STELLA V+ INOX	STELLA V+ S/S STEAM OUTLET
11	NZ6004	TUBE EV VAPEUR	STEAM SOLENOID VALVE PIPE
12	25902	SORTIE VAPEUR STELLA INOX	STELLA S/S STEAM OUTLET
12	25903	SORTIE VAPEUR STELLA V+ INOX	STELLA V+ S/S STEAM OUTLET
12	NZ1020	SORTIE STEAMAIR STELLA	STELLA STEAMAIR OUTLET
12	NZ1021	SORTIE STEAMAIR STELLA V+	STELLA V+ STEAMAIR OUTLET
13	NZ6005	TUBE EV EAU CHAUDE	HOT WATER SOLENOID VALVE PIPE
14	DV1024	SORTIE EAU CHAUDE REGLABLE	ADJUSTABLE HOT WATER OUTLET
15	NZ6000	TUBE DECOMPRESSION	DECOMPRESSION PIPE
15	NZ6001	TUBE DECOMPRESSION V+	V+ DECOMPRESSION PIPE

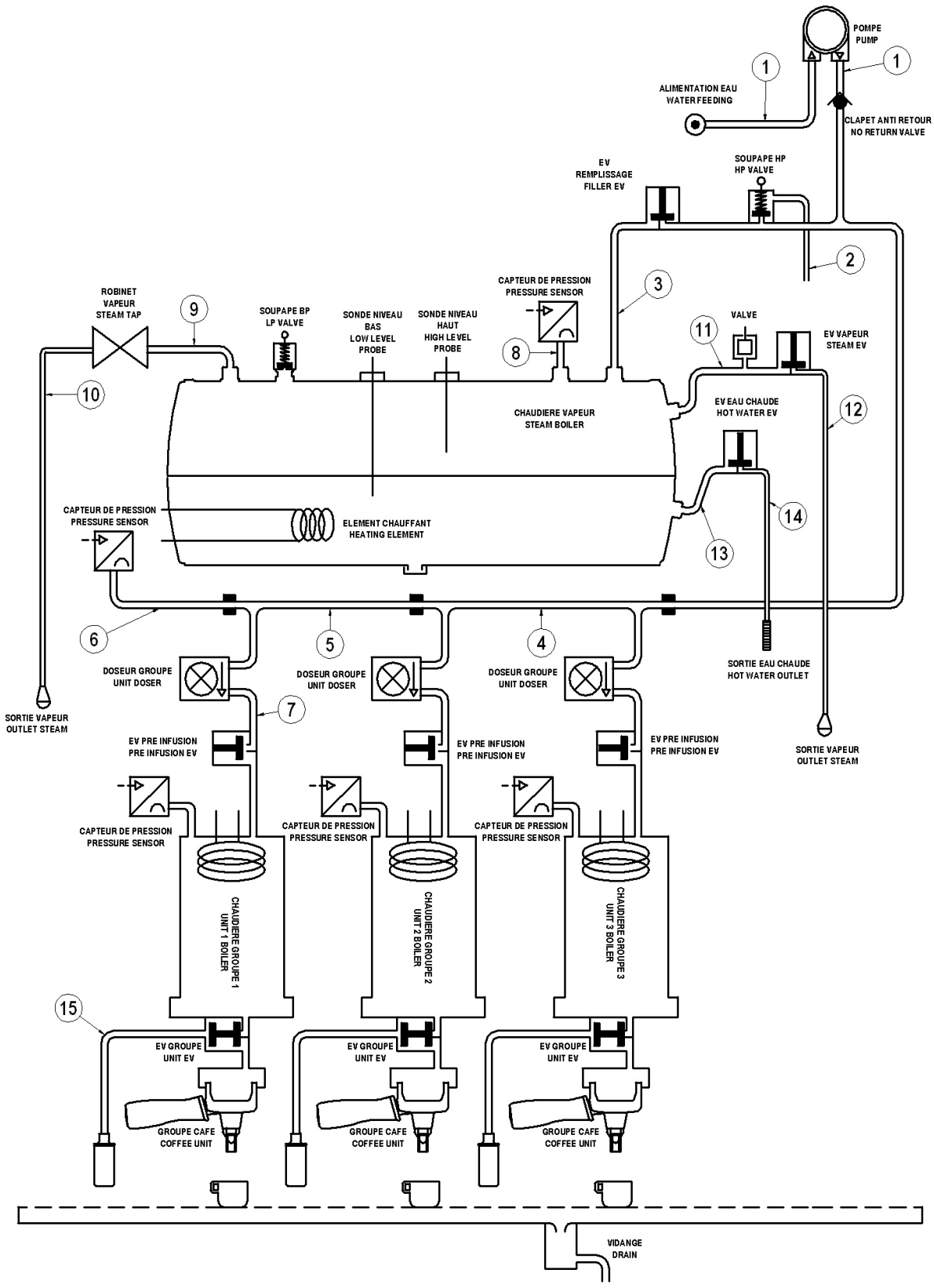

▪ Fuses

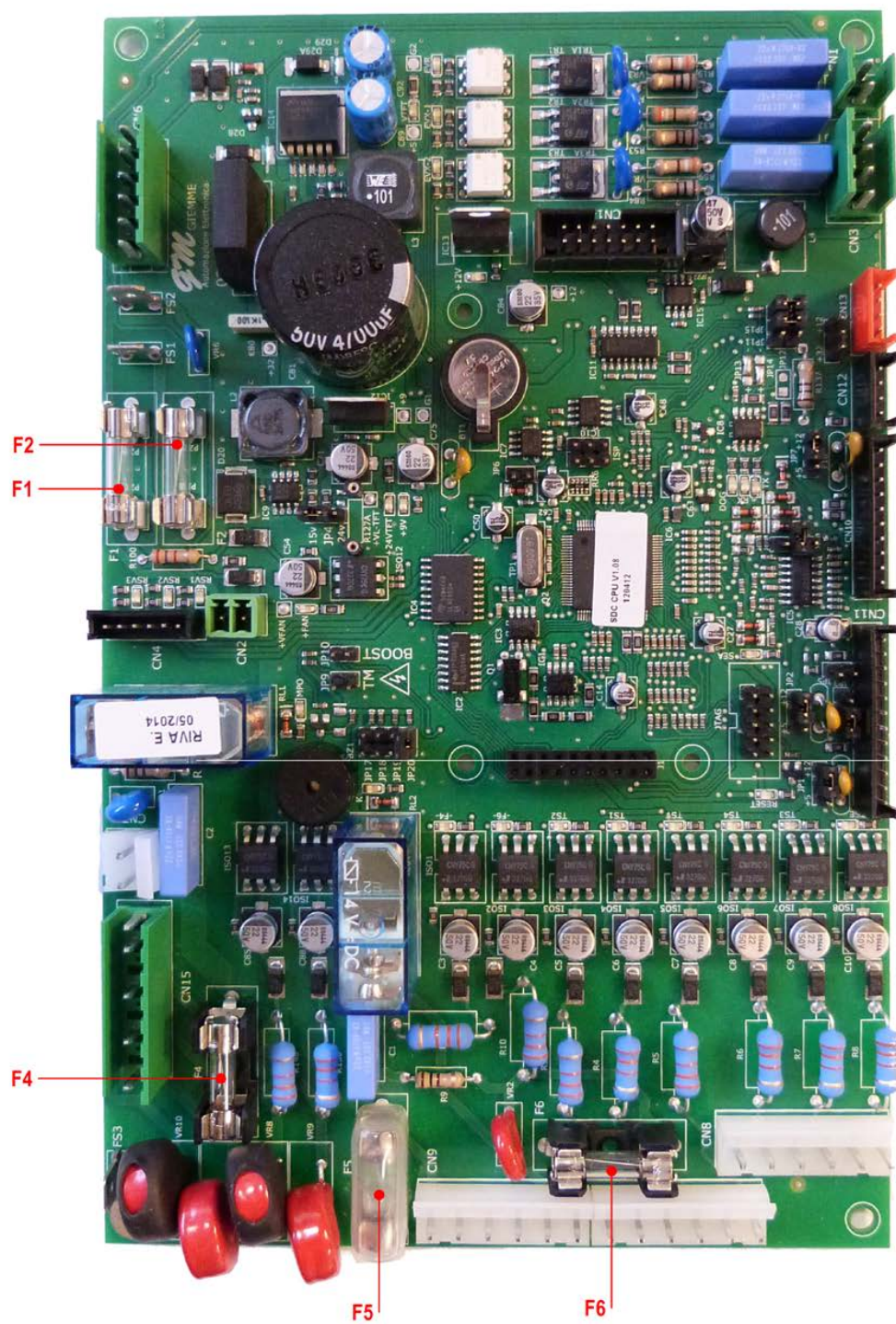

F1	24V BOARD	FUSE, T1AL 250V	43113
F2	24V BGX	FUSE, F10AL 250V	43114
F4	PUMP	FUSE, 5TT5A 125V	43115
F5	SWITCH	FUSE, T2AL 250V	43116
F6	PHASE	FUSE, T1AL 250V	43113

Wiring diagrams

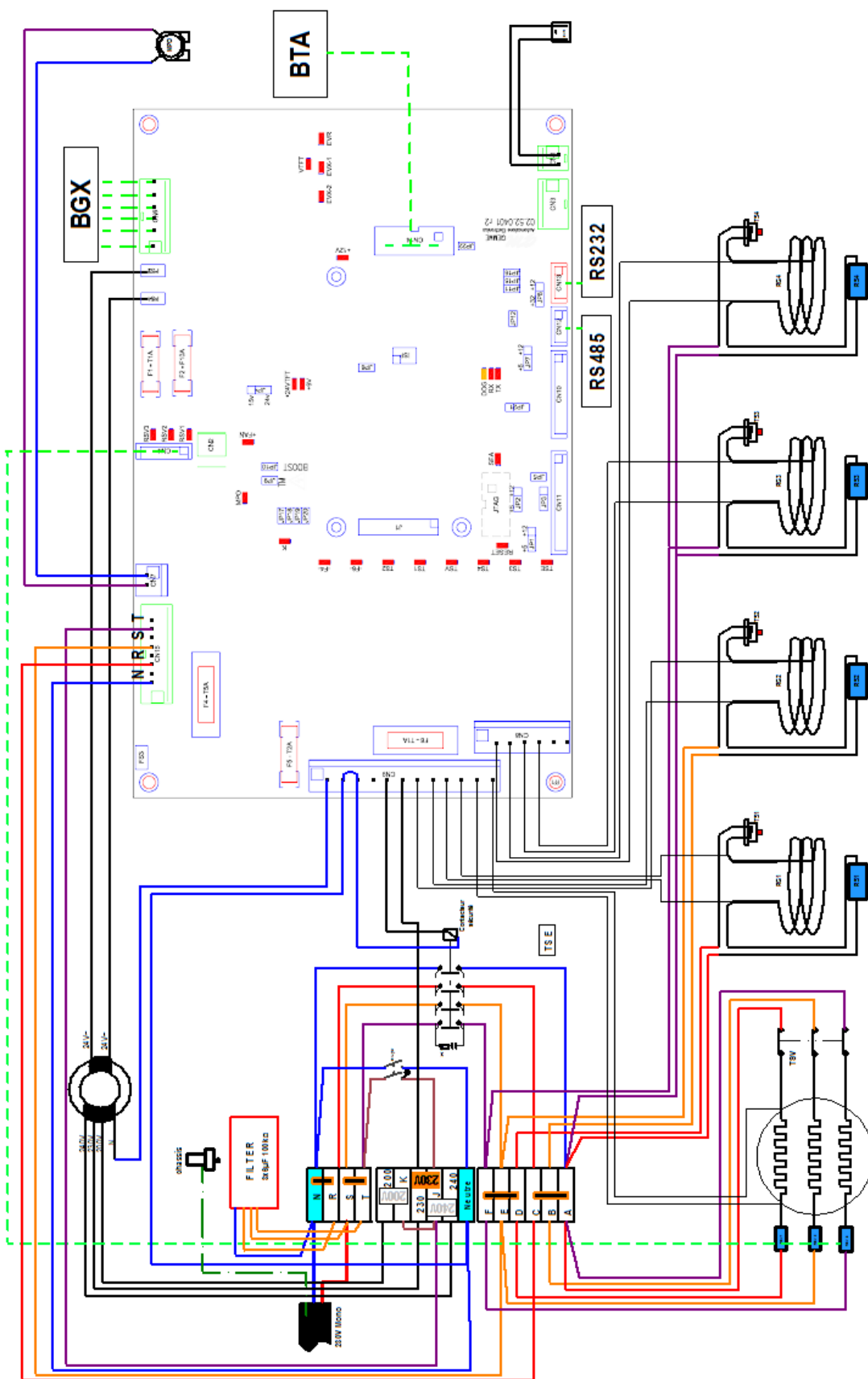

STELLA DICAFFE SCHEMA DE CABLAGE DE PRINCIPE 230V MONO 13/07/2012

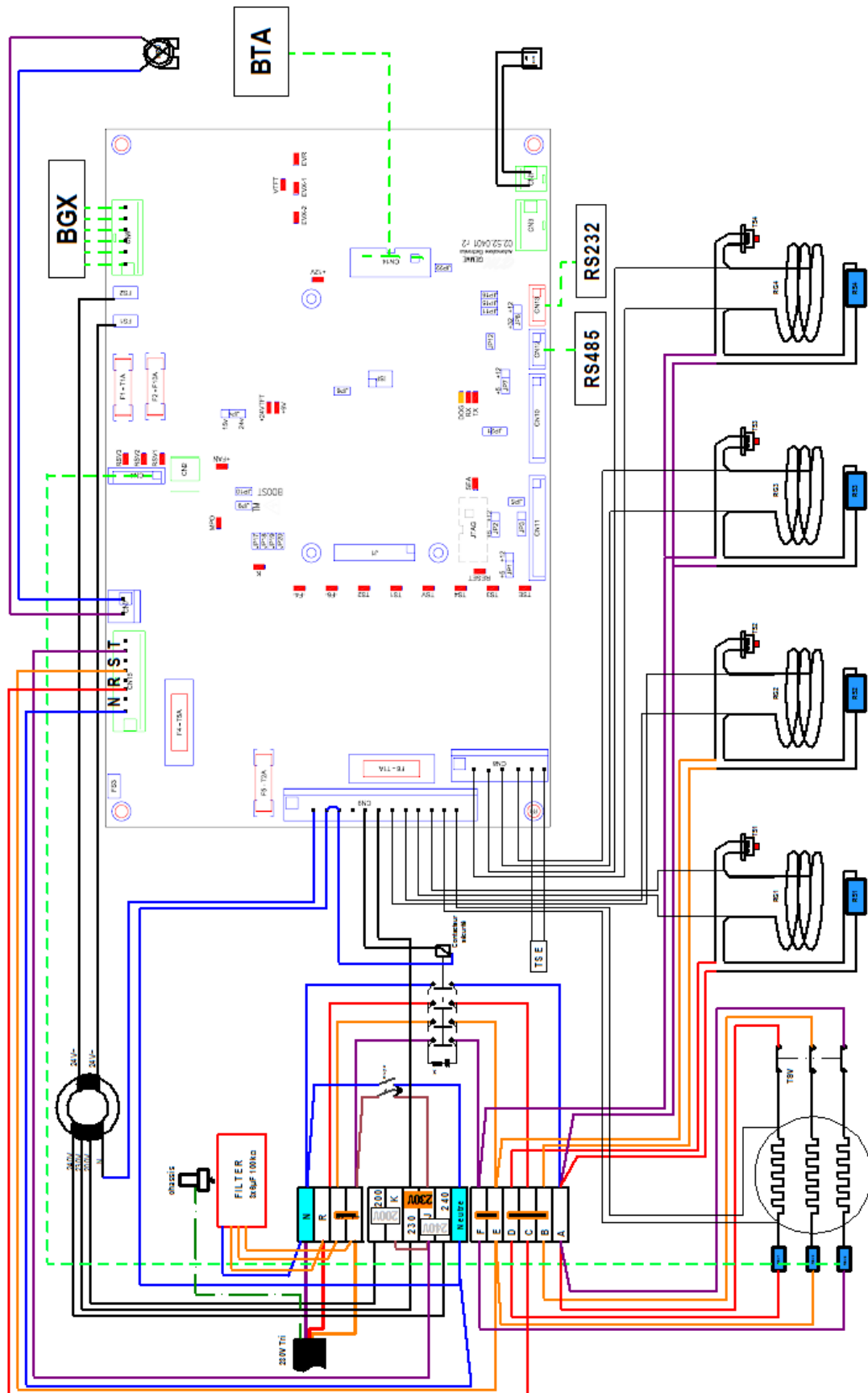

STELLA DI CAFFÈ SCHEMA DE CABLAGGE DE PRINCIPE 230V TRI 13/07/2012

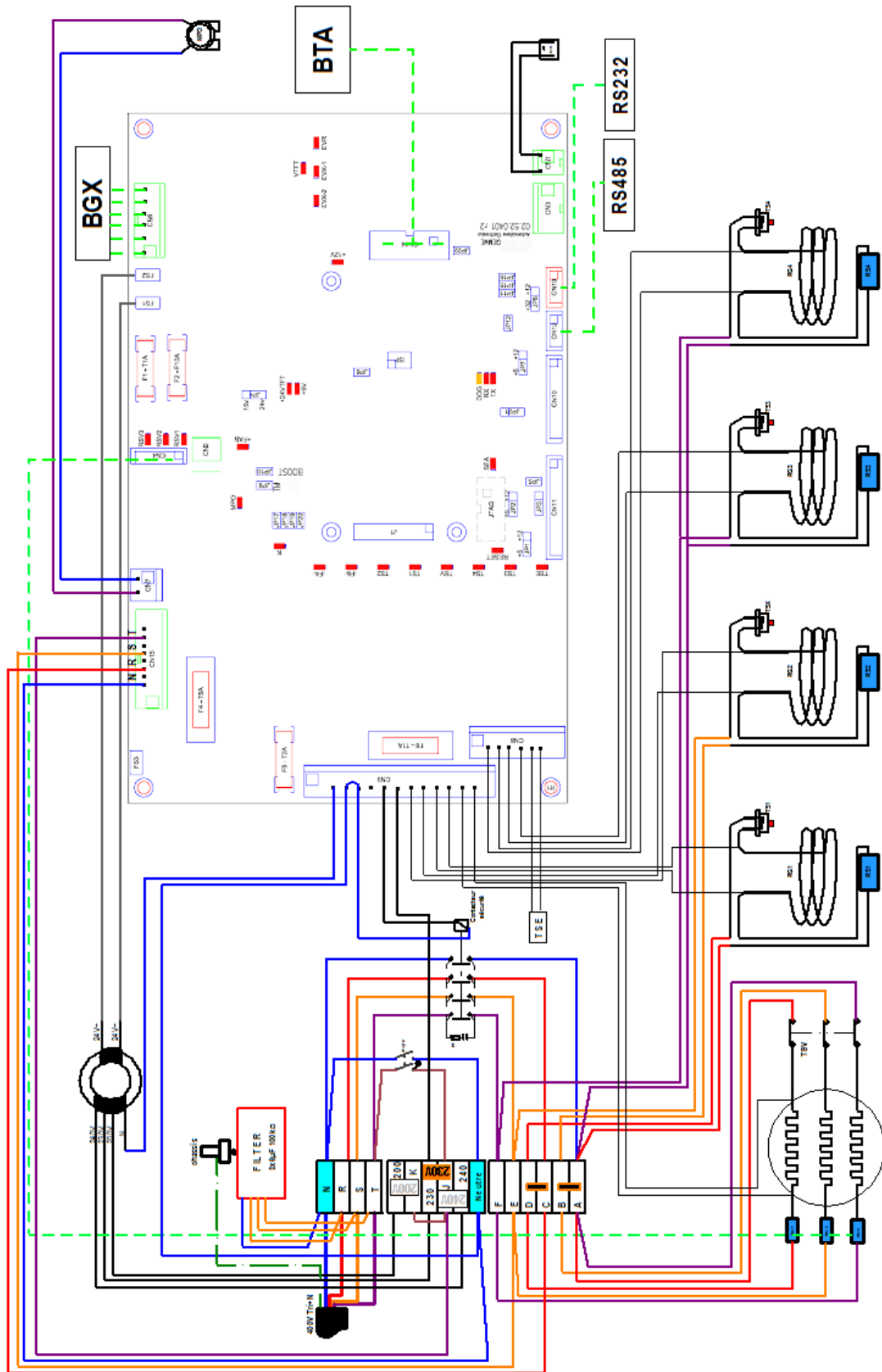

STELLA DI CAFFÈ SCHEMA DE CABLAGGE DE PRINCIPE 400 TRI 13/07/2012

➤ Fitting / replacement procedures

When replacing a **CPU** you should:

- If possible save the machine settings on the **machine USB dongle** (Maintenance → data transfer → settings export)
- Replace the faulty CPU by a new one
- Perform an update of the CPU with a **USB+ dongle**
- Import the CIM configuration from **the machine USB dongle** (Maintenance → data transfer → CIM import) or reconfigure the machine using CIM creator
- Import the machine configuration (Maintenance → data transfer → settings import)

Tools required:

- Flat screwdriver
- 7 mm tube wrench
- 4 mm Allen key

▪ Mother board replacement (CPU)

- Switch off the machine and disconnect the supply plug
- Remove the fixing Allen screw on the left side of the machine, at the back above the cup warmer
- Slide the side panel towards the back to release it from the chassis, and remove it
- Remove the black cover over the fan raceway (A) using a flat screwdriver
- Loosen the screw holding the raceway slightly to allow the raceway to slide towards the front of the machine

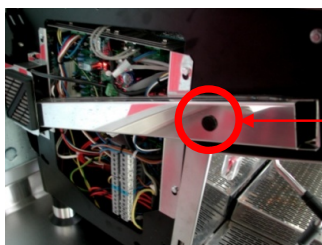

A

Up to the end of 2013

- Remove the caps
- Unscrew the four nuts holding the CPU (B)
- Disconnect all the connectors from the board, marking their positions for refitting
- Pull the board towards you, keeping it horizontal
- Position the new CPU
- Tighten the four screws
- Reconnect the connectors (see appendix and photograph)
- Refit the caps
- Tighten the screw and clip on the cover
- Refit the side panel with its fixing screw

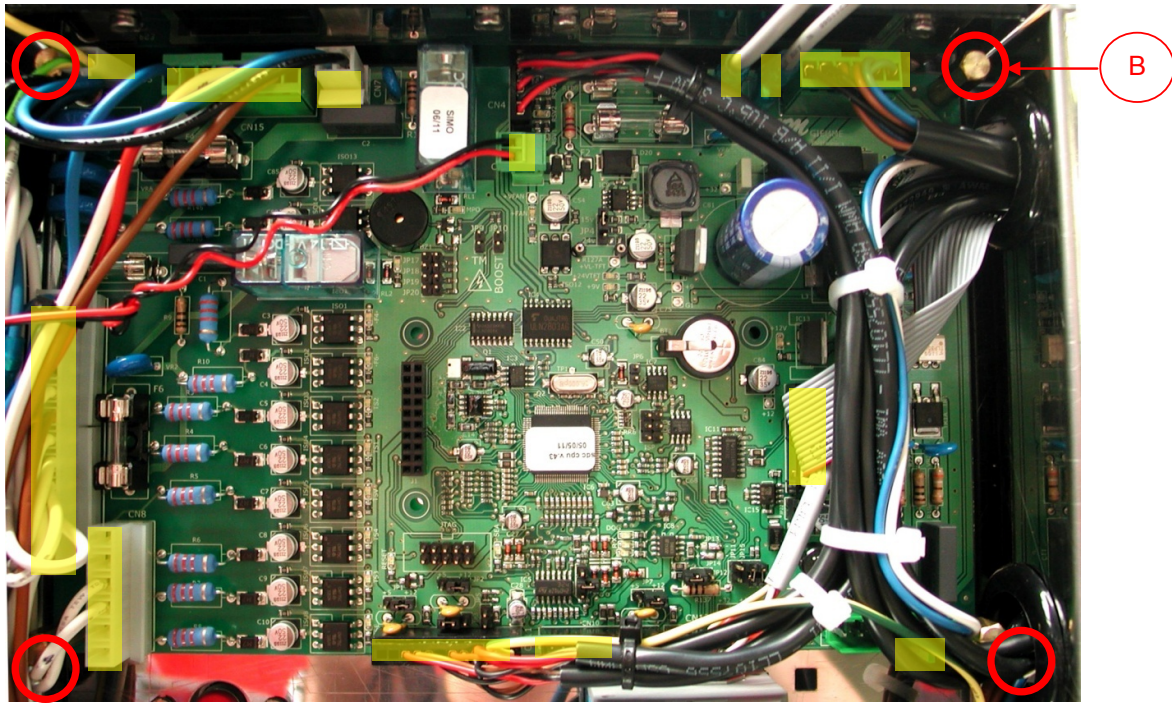

Tools required:

- Flat screwdriver
- Philips screwdriver, PZ1

▪ BTA/BGX/BST control box replacement

- Switch the machine off
- Loosen the two screws (A) under the side grilles of the cup warmer, by approximately 1 cm, and free the front panel from the hooks by pushing the screws towards the back

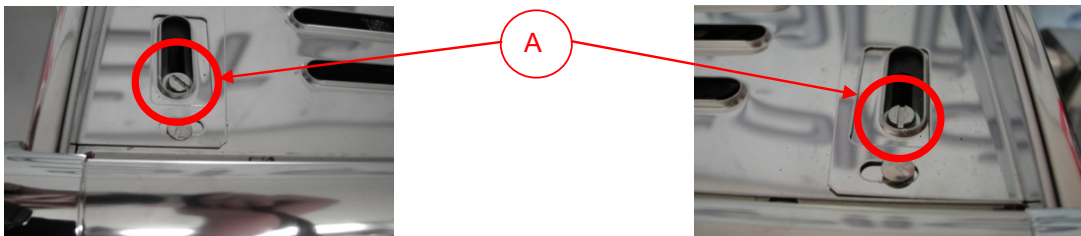

- Tilt the front panel forward to gain access to the wiring
- Disconnect the connectors connecting the front panel to the machine to remove it.
- Place the front panel flat on a protected surface to avoid scratching it and to have access to the screws on the back

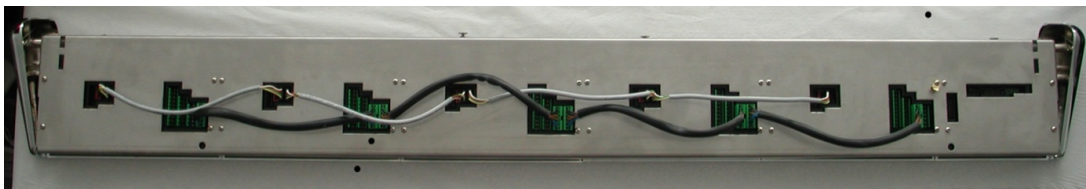

- Loosen the screws holding the top of the panel (B) sufficiently to remove it

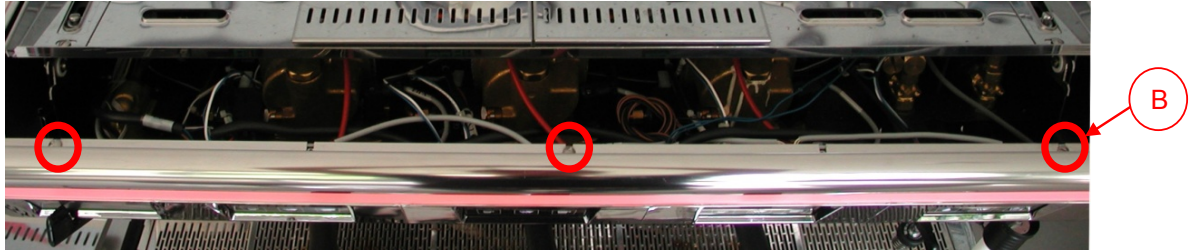

- Remove the strip
- Remove the white steel baffle plate to gain access to the screws holding the cheeks on the sides of the front panel
- Disconnect all the connectors from the control box to be changed and remove its four screws.
- Also loosen the screws holding the adjacent control boxes to leave enough clearance to be able to take the out the control box to be changed (*on a BST or BTA loosen the cheek*)
- Position the new control box and screw up the other control boxes



On a BTA don't tighten the screws too much

- Connect the connectors to the new control box
- Reposition the baffle plate but don't tighten it
- Install the strip
- Once the strip is positioned, push the baffle plate hard against it and tighten the screws.
- Replace the top of the front panel
- Replace the front panel on the machine and connect all the connectors
- Using the document provided in the appendix check that all the front panel wiring is connected to the right places
- Refit the front panel in the hooks and tighten the screws to close them
- Switch the machine on and perform an update on the front panel (see update procedure)

▪ Fitting the long feet

Rear feet (all versions)

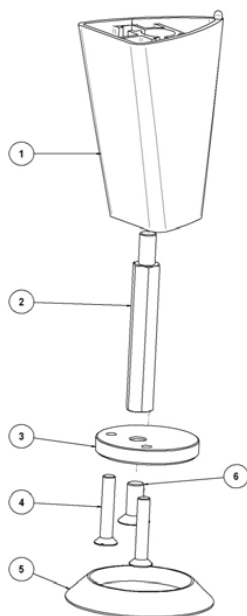

Tools required:

- Flat screwdriver
- 12mm open end spanner or 8mm Allen key
- 7mm open end spanner

- Fit the 2 M6x35 screws (4) to the rear foot base (3).
- Position the long foot (1) on the chassis (1)
- Fix the foot to the chassis with the guide pin screw (2)
- Fix the base and its 2 screws under the foot with the M8x20 screw (6)
- Position the rubber foot (5) on the base

Front feet (standard version)

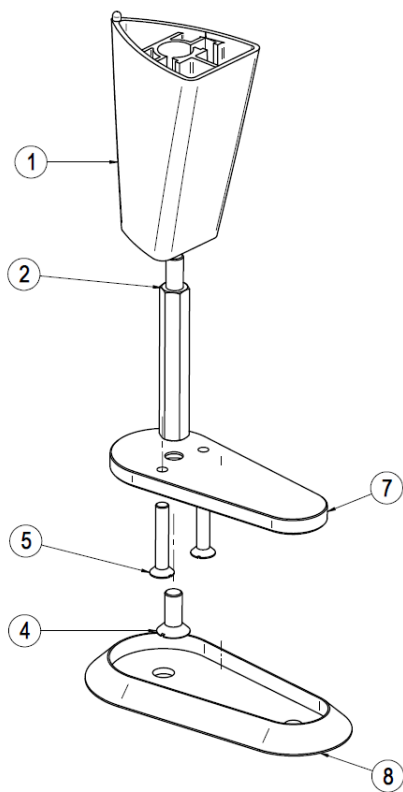

- Assemble the front foot base (7) with the M4x16 screws (5). Take care to fit the shiny face to the top for the visible spacer
- Position the long foot (1) on the chassis (1)
- Fix the foot to the chassis with the guide pin screw (2)
- Fix the base assembly (5, 7) with the M8x20 screw (4)
- Position the rubber foot (8) on the base

Front feet (V+ version)

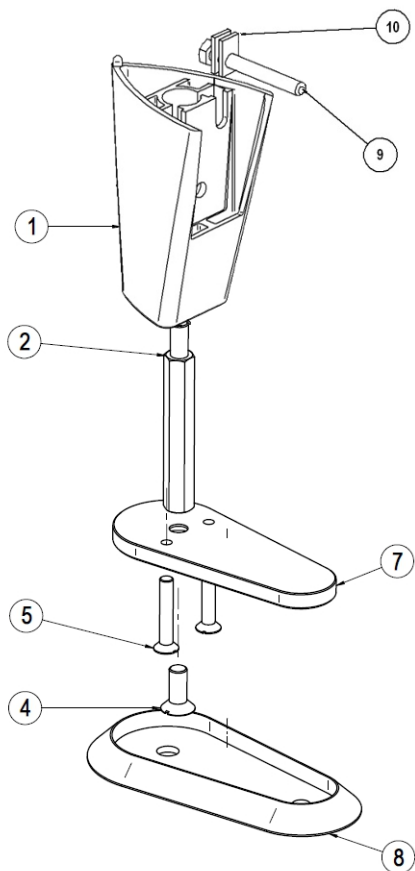

- Assemble the front foot base (7) with the M4x16 screws (5). Take care to fit the shiny face to the top for the visible spacer
- Fit the M6x50 overflow tray mounting screw (9) with its spacer(s) (1x 2mm or 2x 1mm) (10) in the foot (1), positioning it towards the inside of the machine
- Position the long foot (1) on the chassis (1)
- Fix the foot to the chassis with the guide pin screw (2)
- Fix the base assembly with the M8x20 screw (4)
- Position the rubber foot (8) on the base

▪ Removal / replacement of the steam tap cartridge

Tools required:

- 3 mm Allen key
- 25mm open end spanner
- 17 mm tube wrench

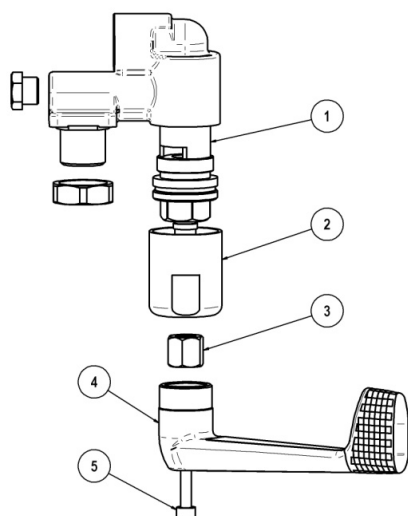

- Take out the handle (4) by loosening the BTR M4x16 screw (5) and save the insert (3)
- Unscrew the cover (2)
- Remove the cartridge (1) from the tap body by unscrewing it
- Reassemble the group in the reverse order of dismantling bearing in mind the following points:
- Make sure there is no dirt or foreign matter that could compromise sealing or operation
- Check that the cartridge is in the closed position and adjust the handle so that it comes as close as possible to the front panel without touching it while remaining on the left of the tap

➤ **Troubleshooting**

▪ List of fault codes for the technician

FAULT CODE	COMPONENTS CONCERNED		POSSIBLE CAUSES	CONSEQUENCES	CONDITIONS FOR EXIT OF THE SECURITY
1	SEA	Mains water pressure sensor/switch	ABSENCE of mains water pressure or tank empty: - Check tap or tank	No filling or cycle possible No heating of coffee boilers if level sensors, SNH and SNB are out of the water	Automatic if fault eliminated
2	SNH	High level sensor	Disconnected or insufficient level after 60 seconds of filling: - Check the sensor and the wiring - Check the filling circuit.	Filling stopped (see special case of 1st fill)	Automatic if fault eliminated
3	SNH SNB	High and low level sensors	Disconnected or level much too low - Check the sensors and the wiring - Check the filling circuit.	Steam boiler heating stopped - EVE and EVV outlets closed - Filling attempt for 60 seconds - if the level rises as far as the SNB the heating restarts - if the level reaches the SNH everything becomes normal again and the EVV and EVE outlets are again usable.	Automatically if everything becomes normal after the filling attempt. If not it is necessary to repair the fault and perform a machine reset.
4	SNB	Low level sensor	Disconnected or lime scale while the SNH is in contact with the water (level correct): - checking the sensor and the wiring	Alarm	Automatic if fault eliminated
5	SNH	High level sensor	disconnected or insufficient level after 3 minutes of the 1st fill: - check the sensor and the wiring - Check the EVR flow	Filling stops	Fault eliminated and Machine reset
6	TSV	STEAM BOILER safety thermostat	triggered following overheating: - Check the STV regulation circuit and the TSV thermostat (manual reset)	Steam boiler heating stopped	Fault eliminated and manual resetting of TSB and machine reset
7	STV	STEAM BOILER thermostat / pressure switch sensor	disconnected, ABSENCE of supply of signal: - Check the sensor and the wiring	Steam boiler heating stopped	Fault eliminated and machine reset
8	STV	STEAM BOILER thermostat / pressure switch sensor	short circuit: - Check the sensor and the wiring	Steam boiler stopped	Fault eliminated and machine reset performed
9	STV	STEAM BOILER thermostat / pressure switch sensor	Reading outside the authorised range: - Check the programmed value and the sensor.	Steam boiler stopped	Fault eliminated
10	TS1	Safety thermostat, GROUP 1	triggered following overheating - Check the regulation circuit SR1 and the thermostat TS1 (manual reset)	Heating stopped on Group 1 - Control box BG1 on stand-by	Fault eliminated and manual reset of TS1 and machine reset
11	SR1	Thermostat sensor, GROUP 1	disconnected, absence of signal: - Check the sensor and the wiring	Heating stopped on Group 1 - Control box BG1 on stand-by	Fault eliminated and machine reset performed
12	SR1	Thermostat sensor, GROUP 1	short circuit: - Check the sensor and the wiring	Heating stopped on Group 1 - Control box BG1 on stand-by	Fault eliminated and machine reset performed
13	SR1	Thermostat sensor, GROUP 1	Reading outside the authorised range: - Check the programmed value and the sensor.	Heating stopped on Group 1 - Control box BG1 on stand-by	Automatic if fault eliminated

FAULT CODE	COMPONENTS CONCERNED		POSSIBLE CAUSES	CONSEQUENCES	CONDITIONS FOR EXIT OF THE SECURITY
14	DO1	Doser, GROUP 1	disconnected, absence of signal: - Check the sensor and the wiring	Manual dosing alarm	Automatic if fault eliminated
15	DO1	Doser GROUP 1	short circuit: - Check the component and the wiring	Manual dosing alarm	Automatic if fault eliminated
16	DO1	Doser, GROUP 1	Interruption in counting for more than 5 seconds: - Check that the doser turbine turns freely and check the wiring (bad contact)	Manual dosing alarm	Automatic if fault eliminated
17	DO1	Doser, GROUP 1	Infusion time more than 110 seconds, insufficient flow: - Check the cleanliness of the hydraulic circuit or increase the grain size.	Infusion cycle stops	Automatic if fault eliminated
18	EH1	DOSAMAT sensor, GROUP 1	disconnected, absence of signal: - Check the sensor and the wiring	Manual start alarm	Automatic if fault eliminated
19	EH1	DOSAMAT sensor, GROUP 1	short circuit: - Check the component and the wiring	Manual start alarm	Automatic if fault eliminated
20	TS2	Safety thermostat on GROUP 2	triggered following overheating - Check the regulation circuit SR2 and the thermostat TS2 (manual reset)	Heating stopped on Group 2 - Control box BG2 on stand-by	Fault eliminated and manual reset of TS2 and machine reset
21	SR2	Thermostat sensor, GROUP 2	disconnected, absence of signal: - Check the sensor and the wiring	Heating stopped on Group 2 - Control box BG2 on stand-by	Fault eliminated and machine reset performed
22	SR2	Thermostat sensor, GROUP 2	short circuit: - Check the sensor and the wiring	Heating stopped on Group 2 - Control box BG2 on stand-by	Fault eliminated and machine reset performed
23	SR2	Thermostat sensor, GROUP 2	Reading outside the authorised range: - Check the programmed value and the sensor.	Heating stopped on Group 2 - Control box BG2 on stand-by	Automatic if fault eliminated
24	DO2	Doser, GROUP 2	disconnected, absence of signal: - Check the sensor and the wiring	Manual dosing alarm	Automatic if fault eliminated
25	DO2	Doser, GROUP 2	short circuit: - Check the component and the wiring	Manual dosing alarm	Automatic if fault eliminated
26	DO2	Doser, GROUP 2	Interruption in counting for more than 5 seconds: - Check that the Doser, turbine turns freely and check the wiring (bad contact)	Dosage alarm or manual stop	Automatic if fault eliminated
27	DO2	Doser, GROUP 2	Infusion time more than 110 seconds, insufficient flow: - Check the cleanliness of the hydraulic circuit or increase the grain size.	Infusion cycle stops	Automatic if fault eliminated
28	EH2	DOSAMAT sensor, GROUP 2	disconnected, absence of signal: - Check the sensor and the wiring	Manual start alarm	Automatic if fault eliminated
29	EH2	DOSAMAT sensor, GROUP 2	short circuit:- Check the component and the wiring	Manual start alarm	Automatic if fault eliminated
30	TS3	Safety thermostat on GROUP 3	triggered following overheating - Check the regulation circuit SR3 and the thermostat TS3 (manual reset)	Heating stopped Group 3 box BG3 on stand-by	Fault eliminated and manual reset of TS3 and machine reset
31	SR3	Thermostat sensor, GROUP 3	disconnected, absence of signal: - Check the sensor and the wiring	Heating stopped Group 3 box BG3 on stand-by	Fault eliminated and machine reset performed
32	SR3	Thermostat sensor, GROUP 3	short circuit: - Check the sensor and the wiring	Heating stopped Group 3 box BG3 on stand-by	Fault eliminated and machine reset performed

FAULT CODE	COMPONENTS CONCERNED		POSSIBLE CAUSES	CONSEQUENCES	CONDITIONS FOR EXIT OF THE SECURITY
33	SR3	Thermostat sensor, GROUP 3	Reading outside the authorised range: - Check the programmed value and the sensor.	Heating stopped on Group 3 Control box BG3 on stand-by	Automatic if fault eliminated
34	DO3	Doser, GROUP 3	disconnected, absence of signal: - Check the sensor and the wiring	Manual dosing alarm	Automatic if fault eliminated
35	DO3	Doser GROUP 3	short circuit: - Check the component and the wiring	Manual dosing alarm	Automatic if fault eliminated
36	DO3	Doser, GROUP 3	Interruption in counting for more than 5 seconds: - Check that the doser turbine turns freely and check the wiring (bad contact)	Dosage alarm or manual stop	Automatic if fault eliminated
37	DO3	Doser, GROUP 3	Infusion time more than 110 seconds, insufficient flow: - Check the cleanliness of the hydraulic circuit or increase the grain size.	Infusion cycle stops	Automatic if fault eliminated
38	EH3	DOSAMAT sensor, GROUP 3	disconnected, absence of signal: - Check the sensor and the wiring	Manual start alarm	Automatic if fault eliminated
39	EH3	DOSAMAT sensor, GROUP 3	short circuit: - Check the component and the wiring	Manual start alarm	Automatic if fault eliminated
40	TS4	Safety thermostat on GROUP 4	triggered following overheating - Check the regulation circuit SR4 and the thermostat TS4 (manual reset)	Heating stopped on Group 4 Control box BG4 on stand-by	Fault eliminated and manual reset of TS4 and machine reset
41	SR4	Thermostat sensor, GROUP 4	disconnected, absence of signal: - Check the sensor and the wiring	Heating stopped on Group 4 Control box BG4 on stand-by	Fault eliminated and machine reset performed
42	SR4	Thermostat sensor, GROUP 4	short circuit: - Check the sensor and the wiring	Heating stopped on Group 4 Control box BG4 on stand-by	Fault eliminated and machine reset performed
43	SR4	Thermostat sensor, GROUP 4	Reading outside the authorised range: - Check the programmed value and the sensor.	Heating stopped on Group 4 Control box BG4 on stand-by	Automatic if fault eliminated
44	DO4	Doser, GROUP 4	disconnected, absence of signal: - Check the component and the wiring	Manual dosing alarm	Automatic if fault eliminated
45	DO4	Doser, GROUP 4	short circuit: - Check the component and the wiring	Manual dosing alarm	Automatic if fault eliminated
46	DO4	Doser, GROUP 4	Interruption in counting for more than 5 seconds: - Check that the doser turbine turns freely and check the wiring (bad contact)	Dosage alarm or manual stop	Automatic if fault eliminated
46	DO4	Doser, GROUP 4	Interruption in counting for more than 5 seconds: - Check that the doser turbine turns freely and check the wiring (bad contact)	Dosage alarm or manual stop	Automatic if fault eliminated
47	DO4	Doser, GROUP 4	Infusion time more than 110 seconds, insufficient flow: - Check the cleanliness of the hydraulic circuit or increase the grain size.	Infusion cycle stops	Automatic if fault eliminated

FAULT CODE	COMPONENTS CONCERNED		POSSIBLE CAUSES	CONSEQUENCES	CONDITIONS FOR EXIT OF THE SECURITY
48	EH4	DOSAMAT sensor, GROUP 4	disconnected, absence of signal: - Check the sensor and the wiring	Manual start alarm	Automatic if fault eliminated
49	EH4	DOSAMAT sensor, GROUP 4	short circuit: - Check the component and the wiring	Manual start alarm	Automatic if fault eliminated
50	DOE	Doser, HOT WATER	disconnected, absence of signal: - Check the sensor and the wiring	Manual dosing alarm	Automatic if fault eliminated
51	DOE	Doser, HOT WATER	short circuit: - Check the component and the wiring	Manual dosing alarm	Automatic if fault eliminated
52	DOE	Doser, HOT WATER	Interruption in counting for more than 5 seconds: - Check that the doser turbine turns freely and check the wiring (bad contact)	Dosage alarm or manual stop	Automatic if fault eliminated
53	DOE	Doser, HOT WATER	Cycle time longer than 110 seconds, insufficient flow: - Check the cleanliness of the hydraulic circuit	Cycle stop : EVE	Automatic if fault eliminated
54	STS	SteamAir sensor	disconnected, ABSENCE of supply of signal: - Check the sensor and the wiring	Alarm, Manual stop	Automatic if fault eliminated
55	STS	SteamAir sensor	short circuit: - Check the sensor and the wiring	Alarm, Manual stop	Automatic if fault eliminated
56	STS	SteamAir sensor	Reading outside the authorised range: - Check the programmed value and the sensor.	Alarm, Manual stop	Automatic if fault eliminated
57	CP1	Pressure sensor, GROUP 1	disconnected, absence of signal: - Check the sensor and the wiring	Alarm	Automatic if fault eliminated
58	CP1	Pressure sensor, GROUP 1	short circuit: - Check the sensor and the wiring	Alarm	Automatic if fault eliminated
59	CP1	Pressure sensor, GROUP 1	Reading outside the authorised range: - Check the programmed value and the sensor.	Alarm - Sensor reading not accepted - Pressure set point replaced by timer (see coffee cycle with pre-infusion)	Automatic if fault eliminated
60	CP2	Pressure sensor, GROUP 2	disconnected, absence of signal: - Check the sensor and the wiring	Alarm	Automatic if fault eliminated
61	CP2	Pressure sensor, GROUP 2	short circuit: - Check the sensor and the wiring	Alarm	Automatic if fault eliminated
62	CP2	Pressure sensor, GROUP 2	Reading outside the authorised range: - Check the programmed value and the sensor.	Alarm - Sensor reading not accepted - Pressure set point replaced by timer (see coffee cycle with pre-infusion)	Automatic if fault eliminated
63	CP3	Pressure sensor, GROUP 3	disconnected, absence of signal: - Check the sensor and the wiring	Alarm	Automatic if fault eliminated
64	CP3	Pressure sensor, GROUP 3	short circuit: - Check the sensor and the wiring	Alarm	Automatic if fault eliminated

FAULT CODE	COMPONENTS CONCERNED		POSSIBLE CAUSES	CONSEQUENCES	CONDITIONS FOR EXIT OF THE SECURITY
65	CP3	Pressure sensor, GROUP 3	Reading outside the authorised range: - Check the programmed value and the sensor.	Alarm - Sensor reading not accepted - Pressure set point replaced by timer (see coffee cycle with pre-infusion)	Automatic if fault eliminated
66	CP4	Pressure sensor, GROUP 4	disconnected, absence of signal: - Check the sensor and the wiring	Alarm	Automatic if fault eliminated
67	CP4	Pressure sensor, GROUP 4	short circuit: - Check the sensor and the wiring	Alarm	Automatic if fault eliminated
68	CP4	Pressure sensor, GROUP 4	Reading outside the authorised range: - Check the programmed value and the sensor.	Alarm - Sensor reading not accepted - Pressure set point replaced by timer (see coffee cycle with pre-infusion)	Automatic if fault eliminated
69	DOG	Doser, GENERAL	disconnected, absence of signal: - Check the sensor and the wiring	Alarm	Automatic if fault eliminated
70	DOG	Doser, GENERAL	Short circuit: - Check the component and the wiring	Alarm	Automatic if fault eliminated
71	DOG	Doser, GENERAL	Interruption in counting for more than 5 seconds during a coffee cycle or filling - Check that the doser turbine turns freely and check the wiring (bad contact)	Alarm	Automatic if fault eliminated
72	TSE	Overheating safety device, WATER BOILER	triggered following overheating - Check the regulation circuit STE and the thermostat TSE (manual reset)	Heating stopped on	Fault eliminated and manual reset of TSE and machine reset
73	STE	Thermostat sensor, WATER BOILER	disconnected, absence of signal: - Check the sensor and the wiring	Heating stopped on	Fault eliminated and machine reset performed
74	STE	Thermostat sensor, WATER BOILER	short circuit: - Check the sensor and the wiring	Heating stopped on	Fault eliminated and machine reset performed
75	STE	Thermostat sensor, WATER BOILER	Reading outside the authorised range: - Check the programmed value and the sensor.	Heating stopped on	Fault eliminated
76	CPR	Pressure sensor, GENERAL	disconnected, absence of signal: - Check the sensor and the wiring	Alarm	Fault eliminated
77	CPR	Pressure sensor, GENERAL	short circuit: - Check the sensor and the wiring	Alarm	Fault eliminated
78	CPR	Pressure sensor, GENERAL	Reading outside the authorised range: - Check the programmed value and the sensor.	Alarm	Fault eliminated
79	CHU	Humidity sensor,	disconnected, absence of signal: - Check the sensor and the wiring	Alarm	Fault eliminated
80	CHU	Humidity sensor,	short circuit: - Check the sensor and the wiring	Alarm	Fault eliminated
81	CHU	Humidity sensor,	Reading outside the authorised range: - Check the programmed value and the sensor.	Alarm	Fault eliminated
82	USB	DATA TRANSFER	INCOMPATIBILITY OF VERSION - TRANSFER IMPOSSIBLE	Alarm	Fault eliminated

FAULT CODE	COMPONENTS CONCERNED		POSSIBLE CAUSES	CONSEQUENCES	CONDITIONS FOR EXIT OF THE SECURITY
83	?	Fuse no 1 Broken	ABSENCE OF SUPPLY 230 V ~	?	?
84	?	Fuse no 2 Broken	ABSENCE OF SUPPLY 24 V	?	?
85	?	Fuse no 3 Broken	ABSENCE OF SUPPLY 12 V	?	?
86	?	Fuse no 4 broken	ABSENCE OF SUPPLY 5 V	?	?
87	?	Fuse no 5 broken	?	?	?
88	?	Fuse broken	?	?	?
89	?	Fuse broken	?	?	?
90	?	Fuse broken	?	?	?
91	DO1	Doser, GROUP 1	First fill fault: the pulse start remained nil for more than 3 sec, or did not fall below 30 pulses per second in less than 3 minutes.	Coffee boiler filling cycle stop: MPO stop - Closure of EV1 and EP1	Fault eliminated and machine reset performed
92	DO2	Doser, GROUP 2	First fill fault: the pulse start remained nil for more than 3 sec, or did not fall below 30 pulses per second in less than 3 minutes.	Coffee boiler filling cycle stop: MPO stop - Closure of EV1 and EP1	Fault eliminated and machine reset performed
93	DO3	Doser, GROUP 3	First fill fault: the pulse start remained nil for more than 3 sec, or did not fall below 30 pulses per second in less than 3 minutes.	Coffee boiler filling cycle stop: MPO stop - Closure of EV1 and EP1	Fault eliminated and machine reset performed
94	DO4	Doser, GROUP 4	First fill fault: the pulse start remained nil for more than 3 sec, or did not fall below 30 pulses per second in less than 3 minutes.	Coffee boiler filling cycle stop: MPO stop - Closure of EV1 and EP1	Fault eliminated and machine reset performed
95			Group filling failure		
96			Failure group 1		
97			Failure group 2		
98			Failure group 3		
99			Failure group 4		
100			Failure group 5		
101			Incompatibility of version		
254			CPU update failure		
255			BGX update failure		

- Troubleshooting



VERY IMPORTANT

Before starting any action check that all the settings are correct

- Temperature 120 °C – steam pressure 0.9 to 1 bar (14PSI)
- Infusion pressure 9 to 10 bar (140 PSI)
- The HP valve opens for values over 13 bar (188PSI)
- Supply pressure: 0 to 6 bar (0 to 90 PSI)
- If the machine use water in a tank, check the tank level and the cleanliness of the foot valve /strainer if one is fitted



PRECAUTIONS TO BE TAKEN

- Switch the machine off and disconnect the electricity supply before doing any work on the electrical circuits
- Cool the machine and release the pressure using the cooling programme (see page 74) before doing any work on the hydraulic circuit

- Replacing a faulty control box:

Replacing the BTA control box

When replacing a **BTA** control box you should:

- Replace the faulty control box by a new one
- Perform an update on the BTA with a **USB+** dongle

Replacing the BGX /BST control box (Part no: 45100, 45101, 45102, 45103, 45104 or 45105)

When replacing a **BGX or BST** control box you should:

- Replace the faulty control box by a new one
- Perform the assignment process of the new control box (see control box assignment heading)
- Perform an update on the BGXs with a black USB dongle

- Individual test procedure for internal components

This enables you to check the operation of the components

Menu → Settings → Component tests



Insert the USB dongle and click on Settings.

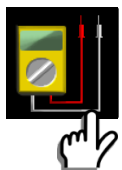

Click on Component tests.

The following screen appears:

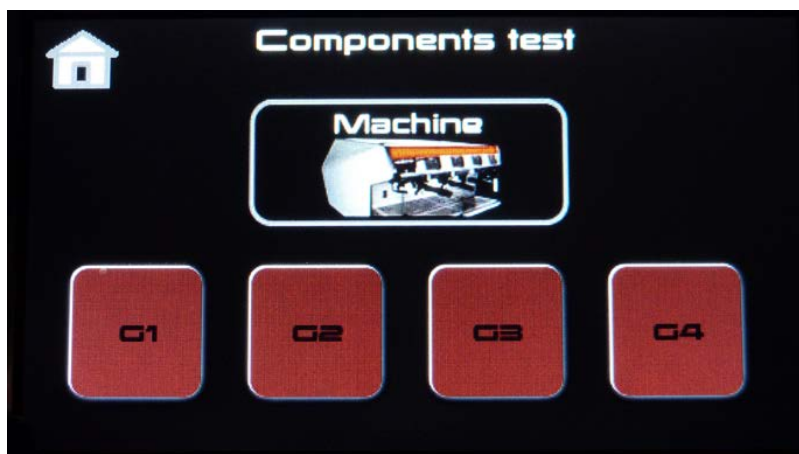

A. Group:

Component code	Component name	Line action
EVx	Coffee solenoid valve	Press = component on for max. 5sec Release = component off
EVPx	Pre-infusion solenoid valve	“
RSx	Solid-state relay command	“
DOx	Water flow control	Press= pump and solenoid valve of group (EVx) on for 10sec (see detail)

Selection of group:

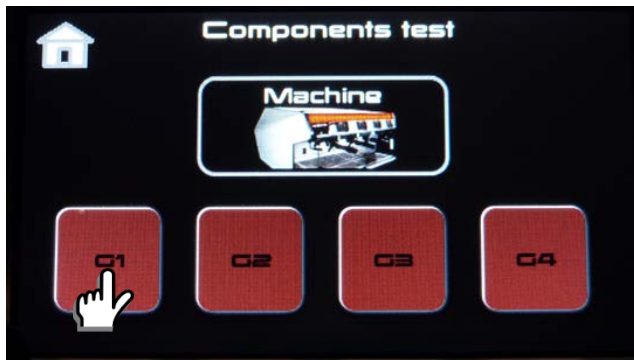

Press = component on for max. 5sec
Release = component off

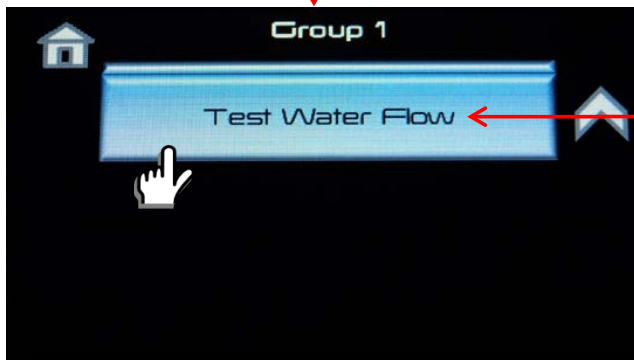

Press= pump and solenoid valve of group (EVx) on for 10 sec (see detail)

It is possible to stop the cycle by pressing the key again (modif. of 30/01/13)

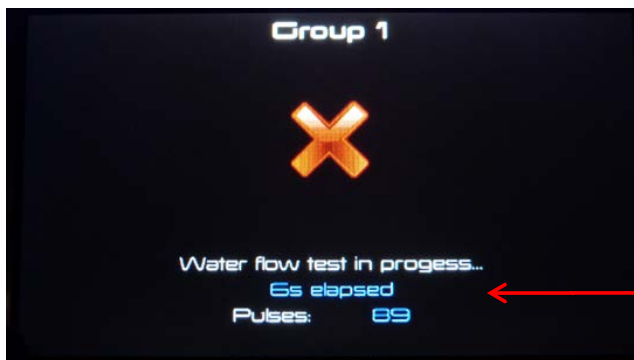

During the test, the display counts down from 10 sec.

The display increments the seconds and the pulses, and holds the display at the end of the cycle. (modif. of 30/01/13)

B. Machine

Component code	Component name	Line action
	Switch <i>(If it is possible)</i>	Press = component on for max. 5sec Release = component off
MPO	Pump	
EVR	Filling solenoid valve	ditto
RSV1	Solid-state steam relay1	ditto
RSV2	Solid-state steam relay2	ditto
RSV3	Solid-state steam relay3	ditto
EVV	Steam solenoid valve	ditto
EVE	Hot water solenoid valve	ditto
DOE	Hot water flow control	Press= hot water solenoid valve (EVE) on for 10sec (see detail)

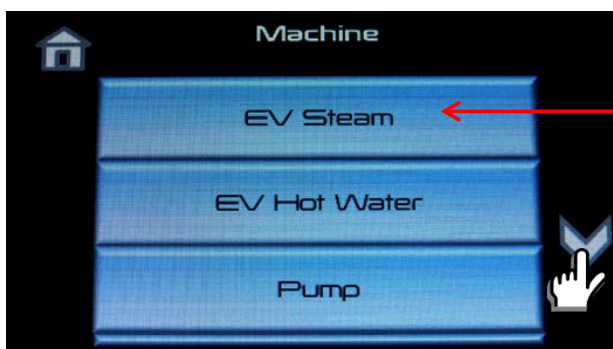

Press =
component on
for max. **5sec**
Release =
component off

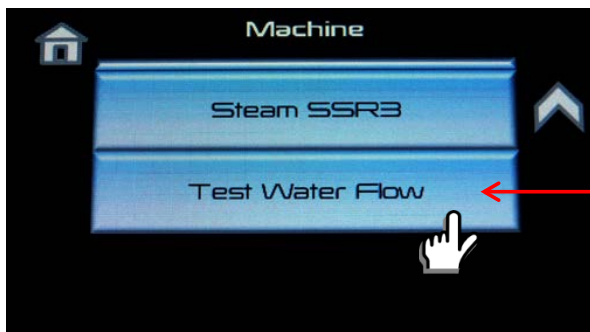

Press= hot water solenoid valve (EVE) on for 10 sec (see detail)

It is possible to stop the cycle by pressing the key again (modif. of 30/01/13)



During the test, the display counts down from 10 sec.

The display increments the seconds and the pulses, and holds the display at the end of the cycle. (modif. of 30/01/13)

Total pulses of the water doser DOE over 10sec

Important:

- When in the “component tests” menu the machine goes into the “test” mode; all the keyboards are disabled and their lights go off (BGX and BST), the heating of the groups and the steam is disabled
- The group selected is illuminated in red
- During an operation the group selected flashes red
- When we exit from the “component tests” menu the machine returns to normal operation.

➤ Cooling



To use the cooling function, go into maintenance → cooling → select the groups; a cycle of 100 seconds starts, execute 3 cycles of 100 seconds to cool a group.

➤ Computer system

- Insert the USB+ dongle



Click on cancel

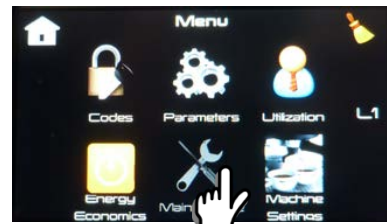

Click on maintenance



Click on CIM



Click on external connections



In the external connections menu press on the text to change the type of computer connection. You will have the choice between:

- Disabled (computer connection)
- Credit/Debit
- Debit/Credit
- RS232

Once you have chosen your type of connection, confirm

PRINCIPE DE GESTION INFORMATIQUE

CREDIT - DEBIT

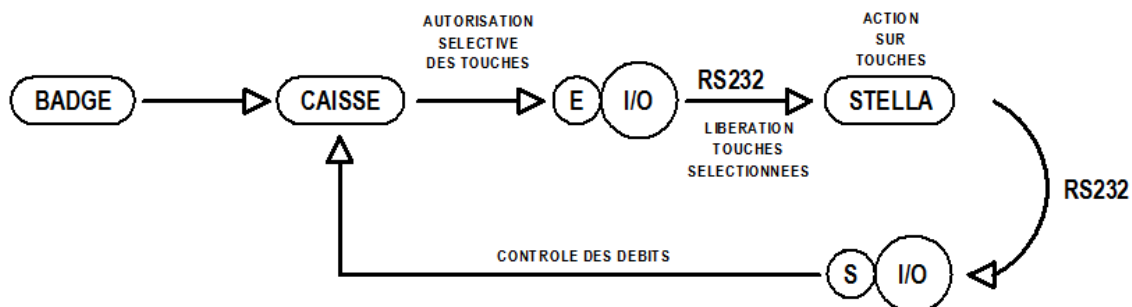

DEBIT - CREDIT *

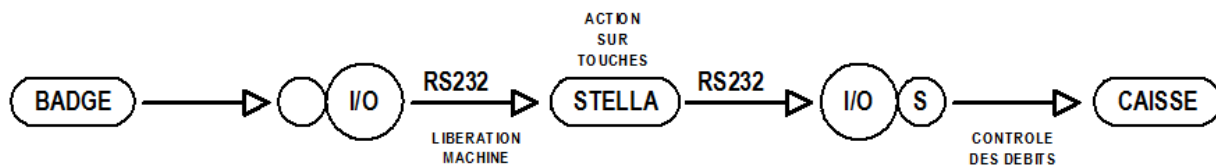

* Les entrées (E) de (I/O) ne sont pas utilisées

RS232 - DIRECT

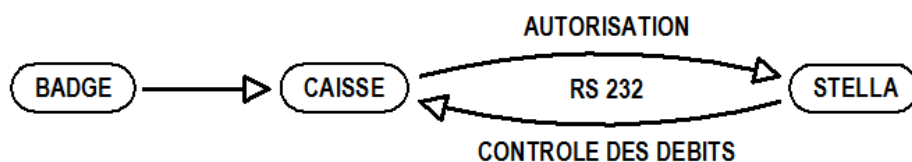

SYNOPTIQUE

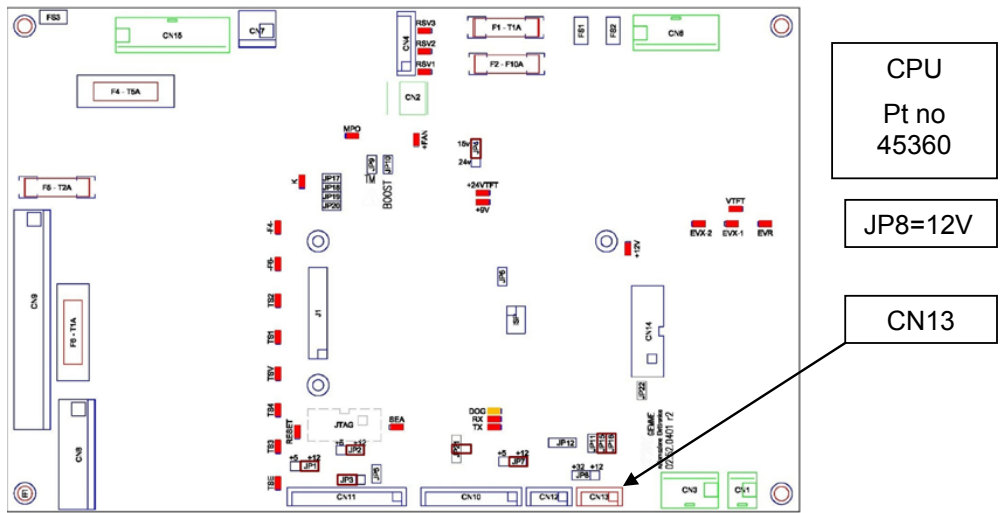
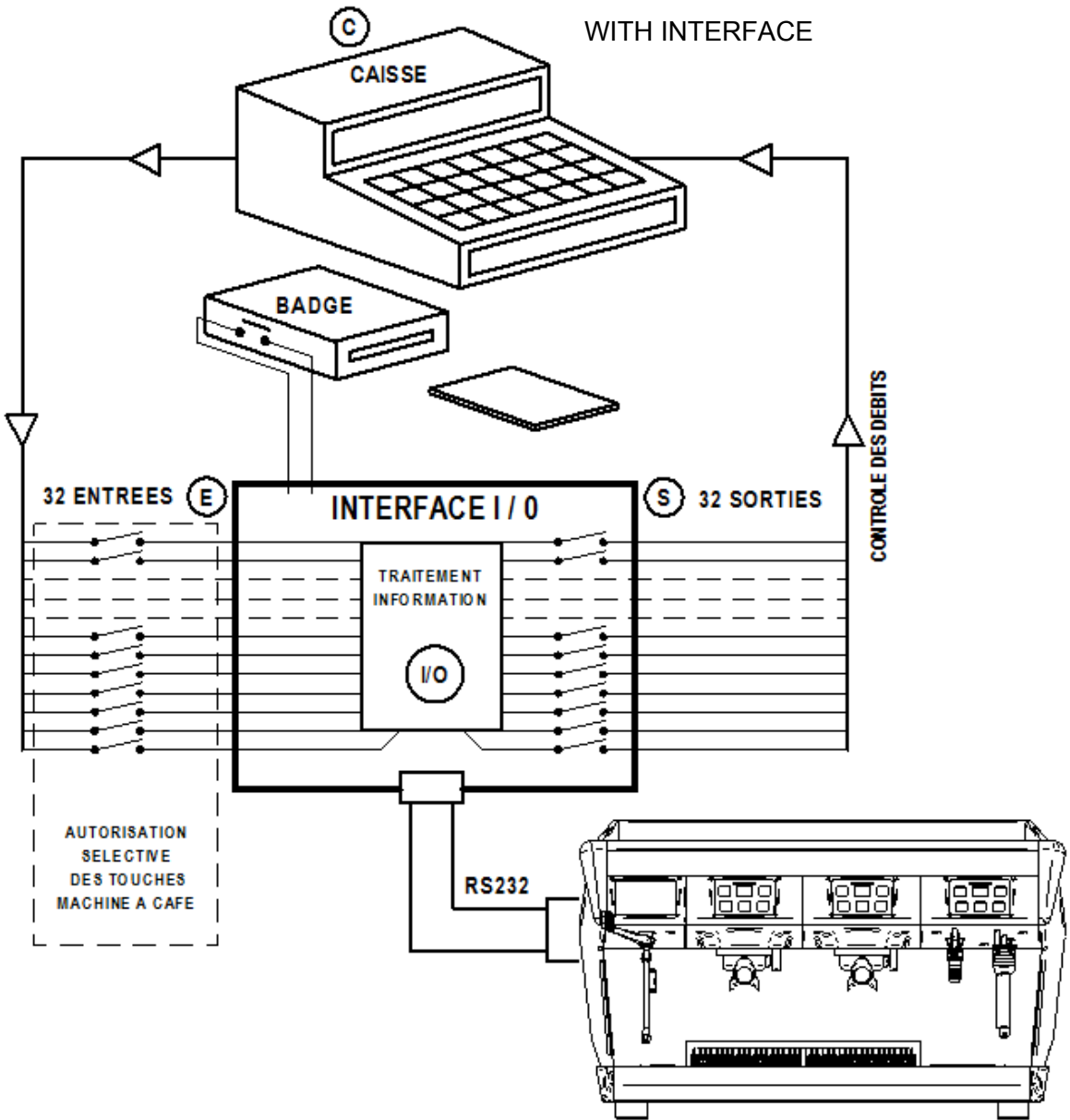

SYNOPTIQUE

WITHOUT INTERFACE

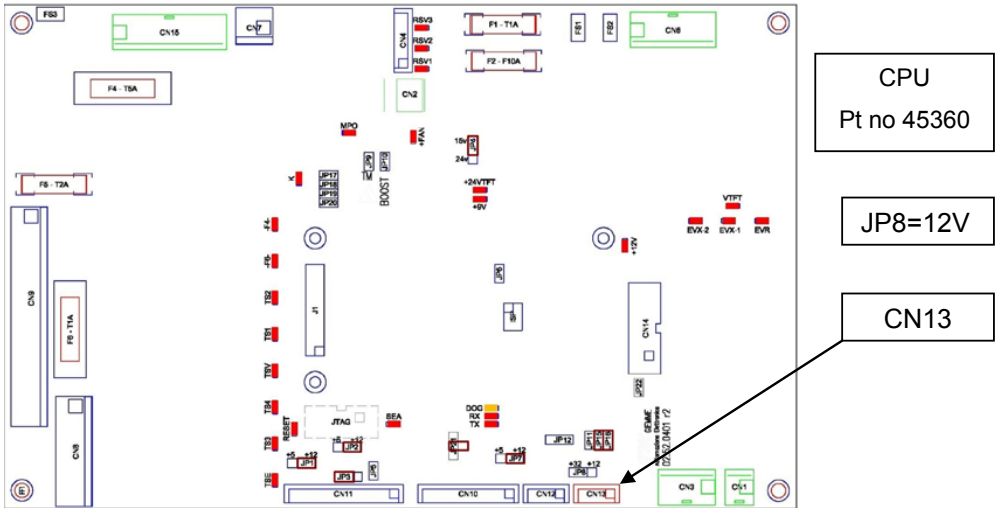
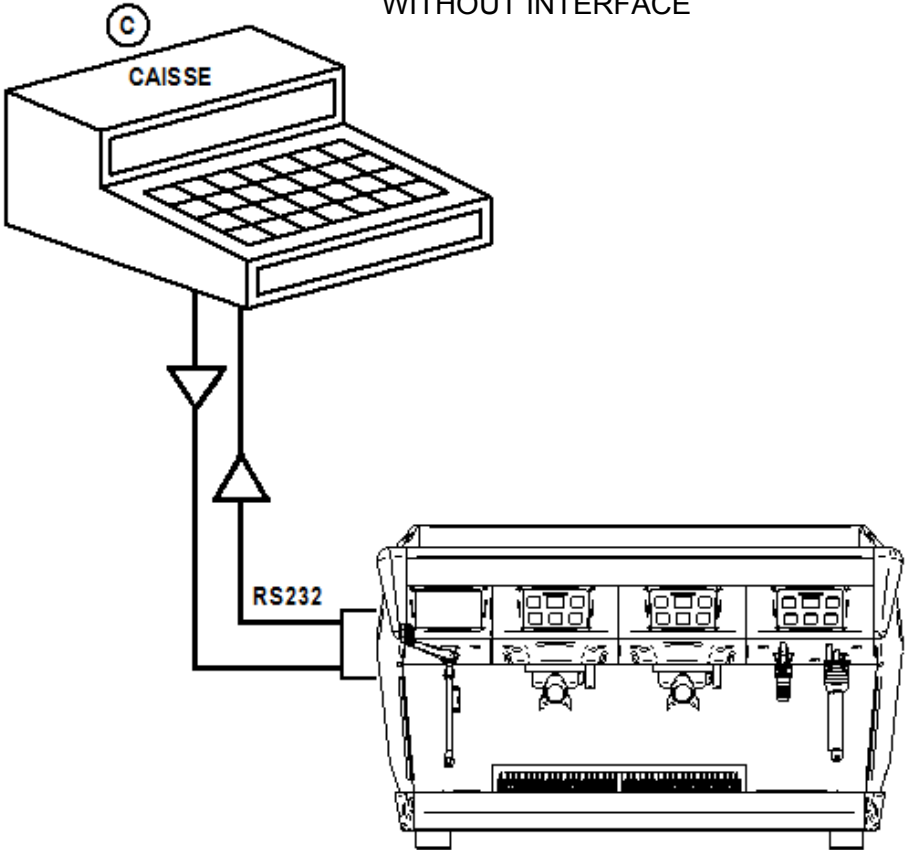

Note: the coffee machine is only usable when the badge contact is closed.

To simulate the presence of the badge it is possible to connect points 33 and 35 of connector CN7 of the main interface.

For the machine to work without the I/O interface, either connect points 2 and 3 of cable part no: NZ8018 or make a strap between points 2 and 3 of connector CN13 (red).

IMPORTANT: THE CONNECTION CAN ONLY BE MADE WITH MACHINES FITTED WITH VERSION V1.0 OR HIGHER.

To configure the machine in a computer system, with the technician's key activate the desired mode in the maintenance / CIM menu and fit or remove a **JP3** strap of the interface (see below) and position strap **JP8** of the **CPU board** on 12V.

JP3 STRAP: allows configuration in Credit / Debit (CD) or Debit / Credit (DC).

To configure the interface in DC, **fit strap JP3.**

To configure the interface in CD, **remove strap JP3.**

TRANSMISSION SETTINGS:
- 1200 bit / sec.
- Parity EVEN
- 8 bit of data

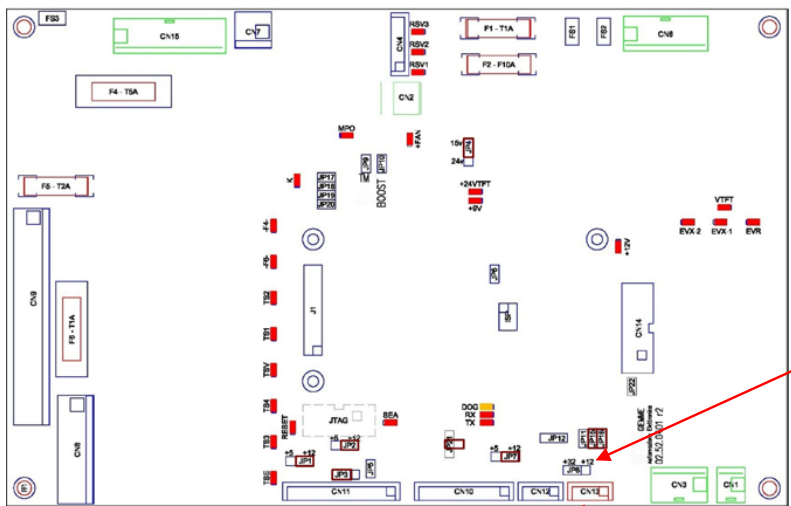

Connect NZ8018 to CN13

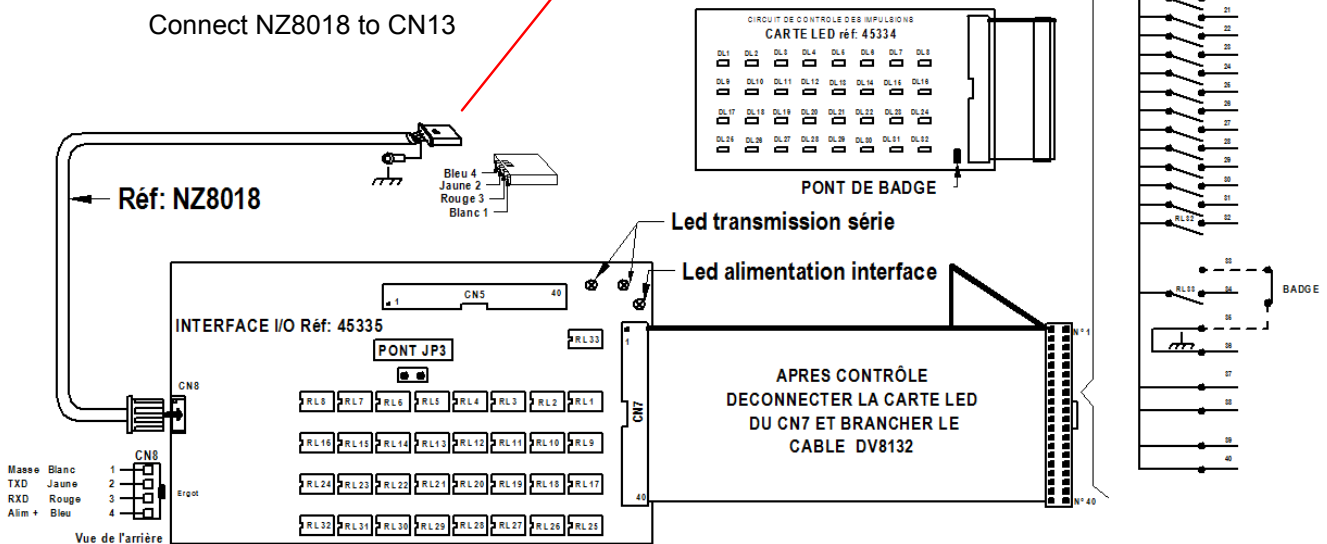

- Debit – Credit system

Code = code sent by the machine to the IO-32 board (or to the payment system)

RL = active relay on the IO-32 board

Type of control box	Cup volume or dose	BG1		BG2		BG3		BG4		BST	
		Code	RL	Code	RL	Code	RL	Code	RL	Code	RL
Manual (ON/OFF)		11	1	1D	7	29	13	16	19	----	----
2 cups	1 small	11	1	1D	7	29	13	16	19	----	----
	2 small	13	2	1F	8	2B	14	18	20	----	----
	1 large	17	4	23	10	2F	16	59	22	----	----
	2 large	19	5	25	11	12	17	50	23	----	----
3 cups	1 small	11	1	1D	7	29	13	16	19	----	----
	2 small	13	2	1F	8	2B	14	18	20	----	----
	3 small	15	3	21	9	2D	15	58	21	----	----
	1 large	17	4	23	10	2F	16	59	22	----	----
	2 large	19	5	25	11	12	17	50	23	----	----
	3 large	1B	6	27	12	14	18	52	24	----	----
Dosamat	1 small	11	1	1D	7	29	13	16	19	----	----
	2 small	13	2	1F	8	2B	14	18	20	----	----
	3 small	15	3	21	9	2D	15	58	21	----	----
	1 large	17	4	23	10	2F	16	59	22	----	----
	2 large	19	5	25	11	12	17	50	23	----	----
	3 large	1B	6	27	12	14	18	52	24	----	----
SteamAir	Water (small)	----	----	----	----	----	----	----	----	54	25
	Water (large)	----	----	----	----	----	----	----	----	56	26
	SteamAir	----	----	----	----	----	----	----	----	24	28
	Steam (with timer)	----	----	----	----	----	----	----	----	26	29
Hot water	Water (small)	----	----	----	----	----	----	----	----	54	25
	Water (large)	----	----	----	----	----	----	----	----	56	29

- Credit – Debit system and RS232

Type of control box	Cup volume or dose	BG1		BG2		BG3		BG4		BST	
		Code	RL	Code	RL	Code	RL	Code	RL	Code	RL
Manual (ON/OFF)		11	1	17	7	21	13	27	19	----	----
2 cups	1 small	11	1	17	7	21	13	27	19	----	----
	2 small	80	2	83	8	88	14	8B	20	----	----
	1 large	81	4	86	10	89	16	59	22	----	----
	2 large	15	5	1F	11	25	17	50	23	----	----
3 cups	1 small	11	1	17	7	21	13	27	19	----	----
	2 small	80	2	83	8	88	14	8B	20	----	----
	3 small	13	3	1D	9	23	15	58	21	----	----
	1 large	81	4	86	10	89	16	59	22	----	----
	2 large	15	5	1F	11	25	17	50	23	----	----
	3 large	82	6	87	12	8A	18	C0	24	----	----
Dosamat	1 small	11	1	17	7	21	13	27	19	----	----
	2 small	80	2	83	8	88	14	8B	20	----	----
	3 small	13	3	1D	9	23	15	58	21	----	----
	1 large	81	4	86	10	89	16	59	22	----	----
	2 large	15	5	1F	11	25	17	50	23	----	----
	3 large	82	6	87	12	8A	18	C0	24	----	----
SteamAir	Water (small)	----	----	----	----	----	----	----	----	52	25
	Water (large)	----	----	----	----	----	----	----	----	C2	26
	SteamAir	----	----	----	----	----	----	----	----	56	28
	Steam (with timer)	----	----	----	----	----	----	----	----	22	29
Hot water	Water (small)	----	----	----	----	----	----	----	----	52	25
	Water (large)	----	----	----	----	----	----	----	----	C2	29

➤ System information

Machine maintenance counter:

The machine maintenance counter is only accessible via the USB dongle; press Maintenance > CIM > Information:



It enables us to view:

- The total of all coffees (small, large and continuous)
- The total of all coffees per group (small, large and continuous)
- The servings total of hot water
- The servings total of steam and **SteamAir**

Important:

- It is impossible to reset the **FACTORY** counters without a special USB dongle.

11. STELLA PROGRAMME FLOWCHART

 ➤ Level 0: User

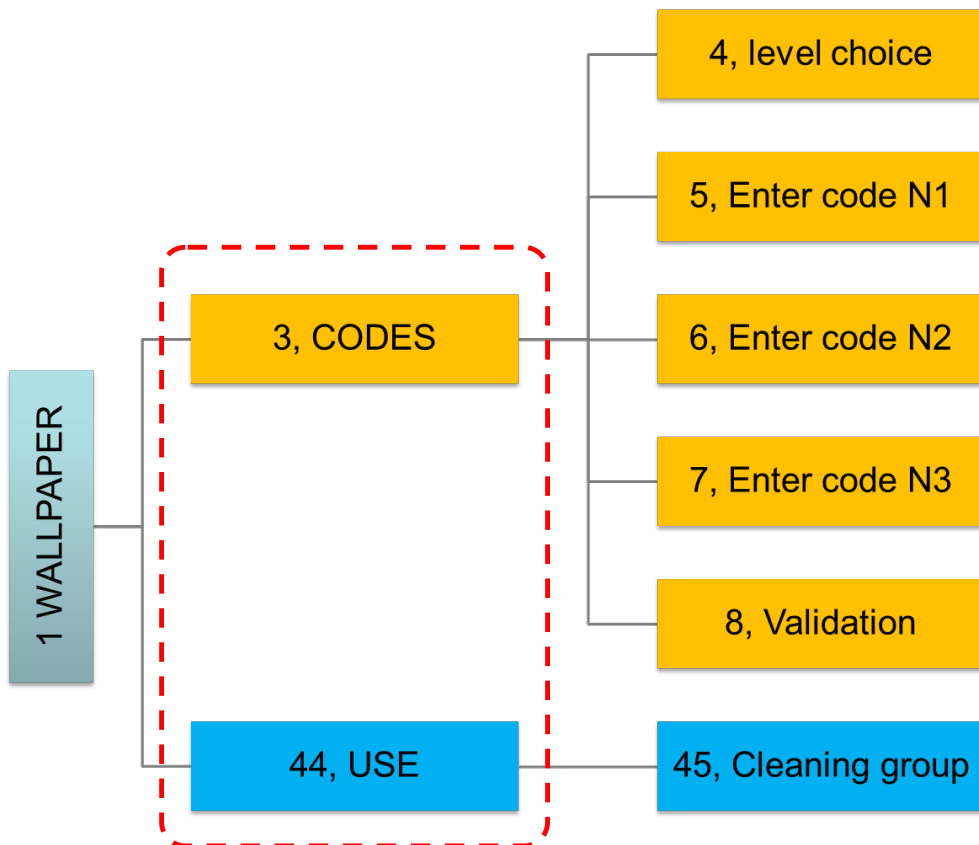

The dotted lines represent the main menu



➤ Level 1: Coffee specialist

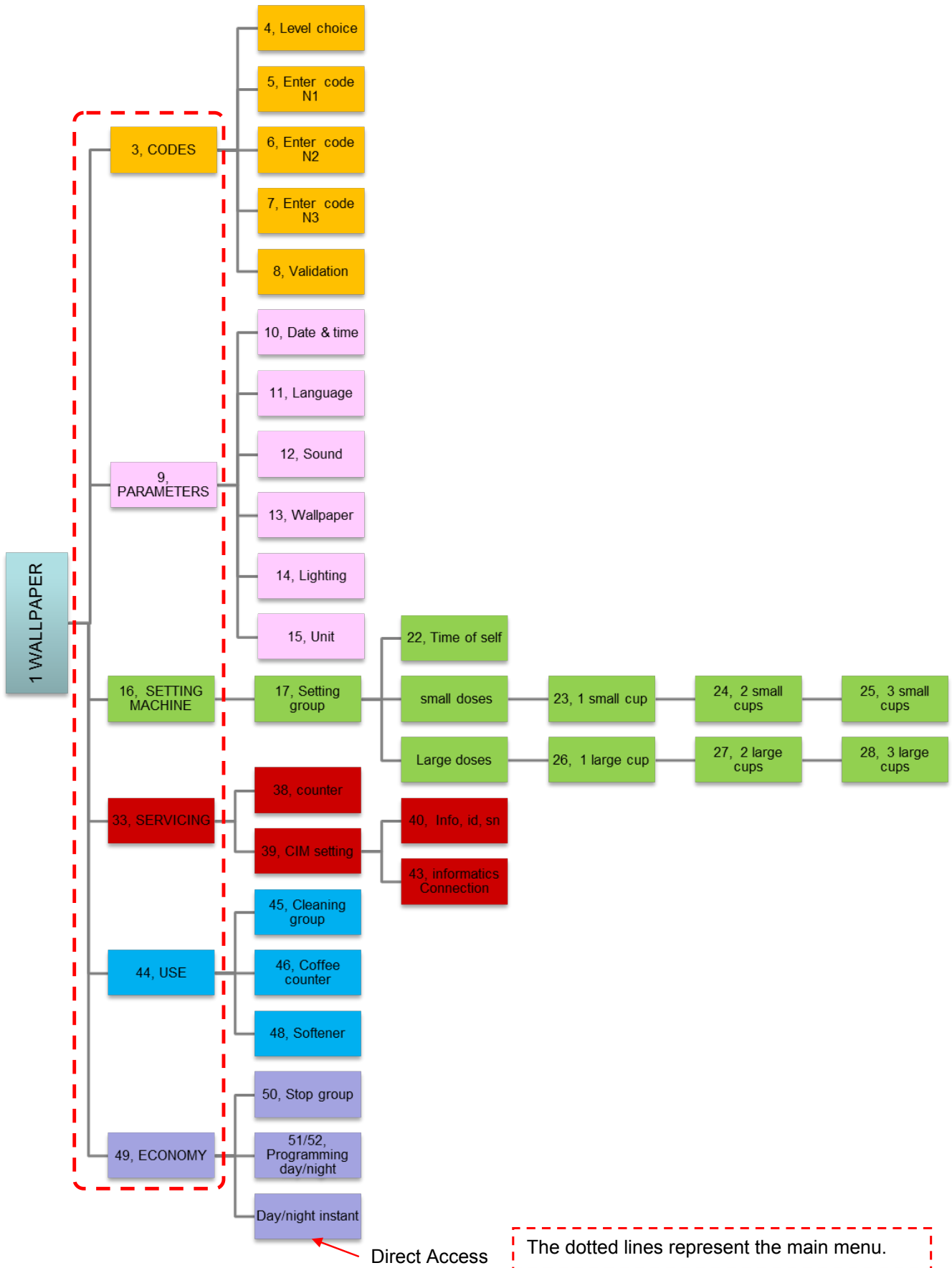



➤ Level 2: Barista

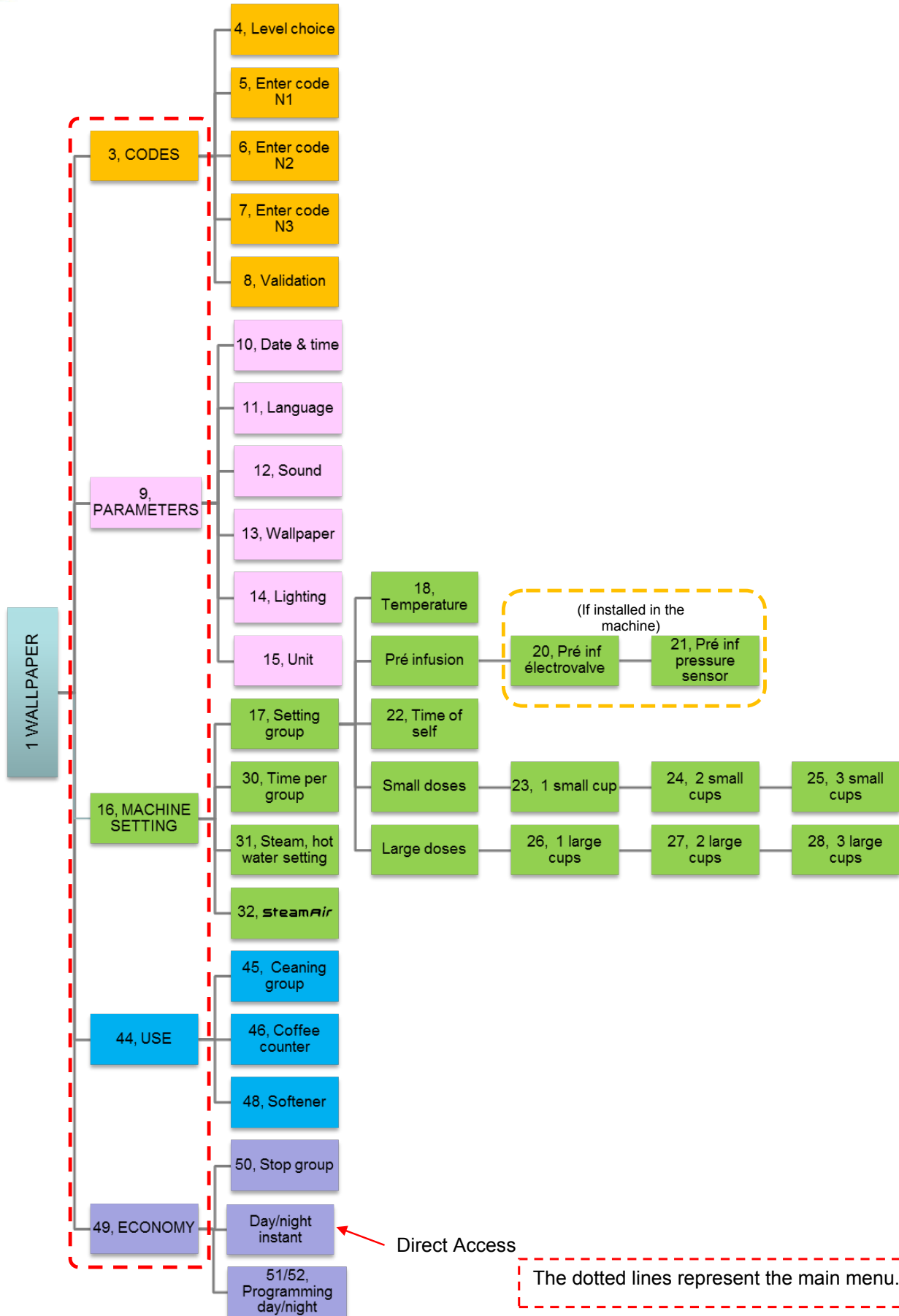



➤ Level 3: Manager / Boss

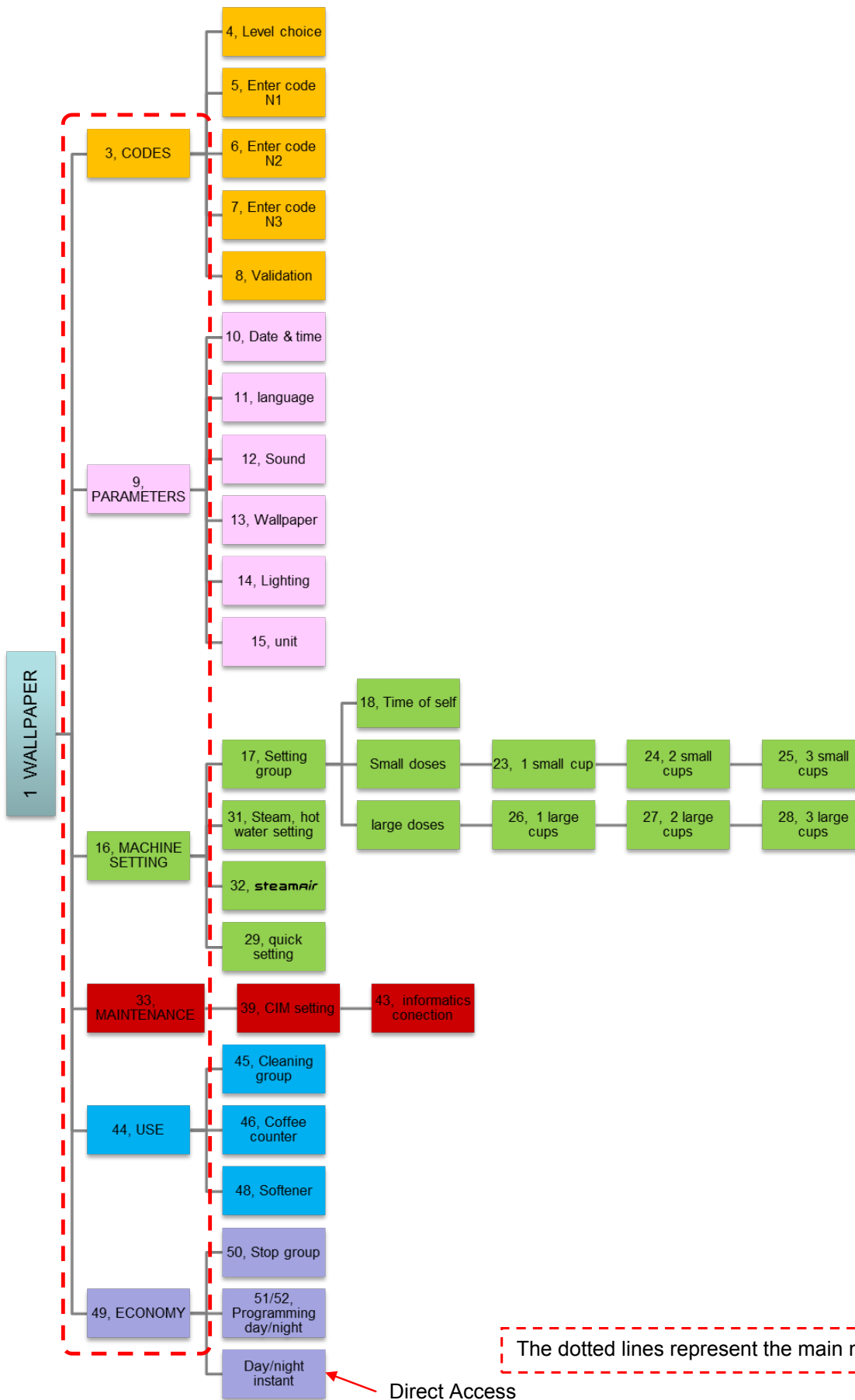

The dotted lines represent the main menu.



Level 4: Technician

USB dongle level



The dotted lines represent the main menu.

Direct Access

12. APPENDICES

Setting values readings:

Date:/...../.....
Customer:	
Machine number:	SDC.....
Programme version:	BTA: CPU: BGX:



Before any major update note the values in the menus below:

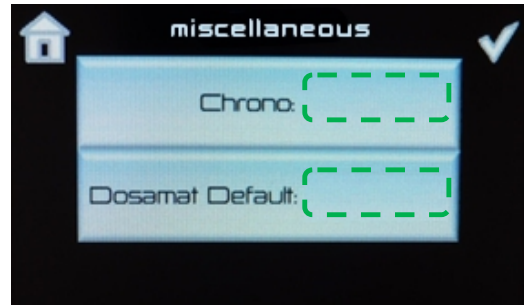
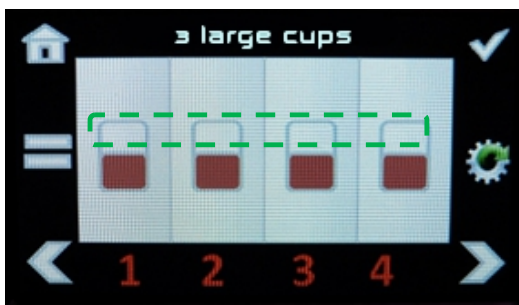
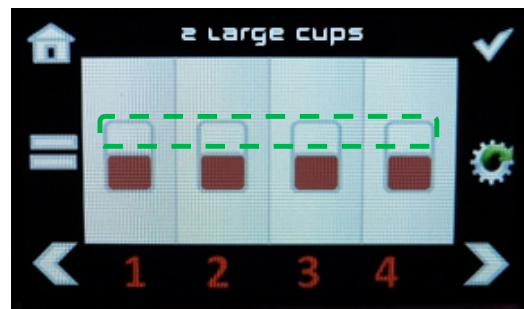
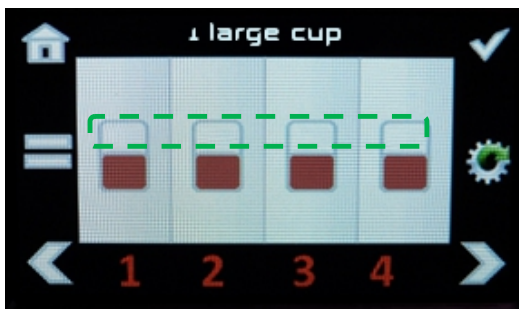
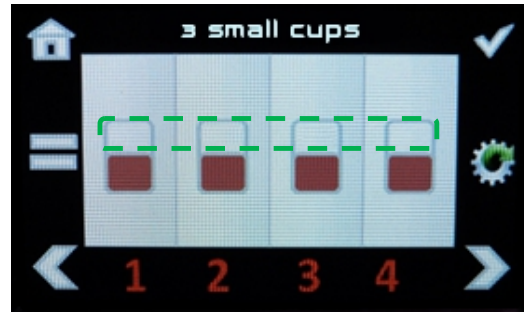
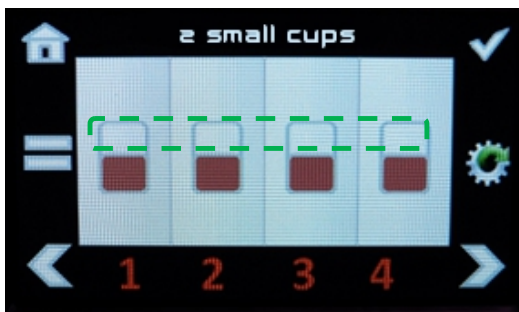
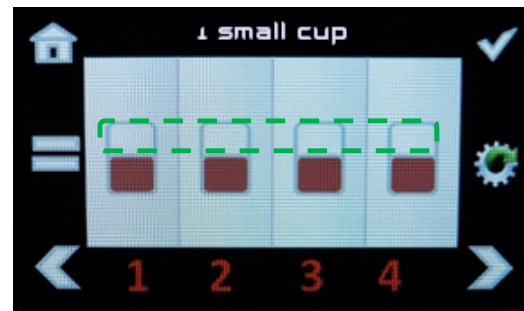
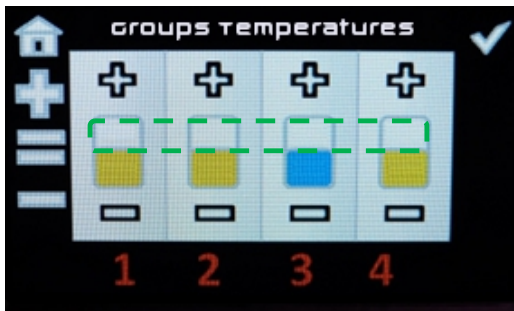

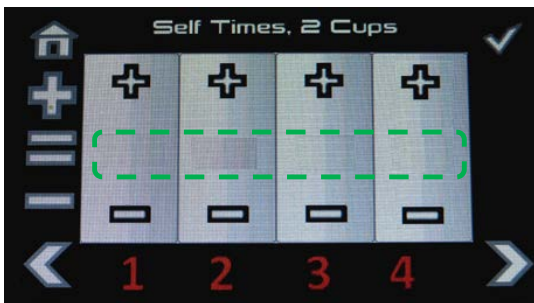
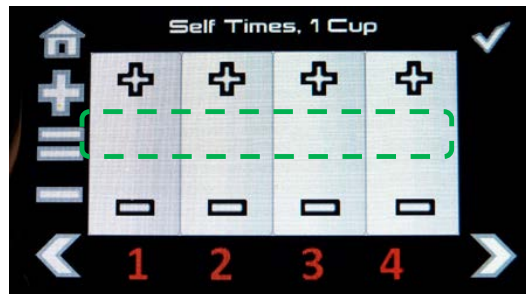
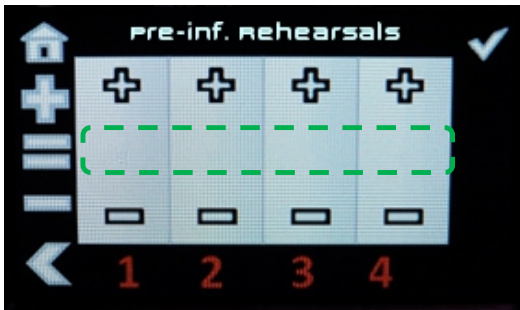
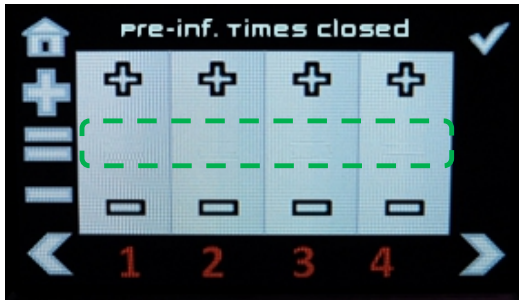
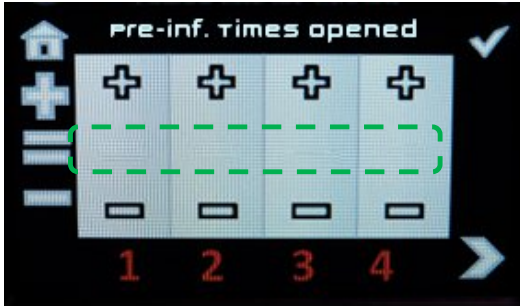
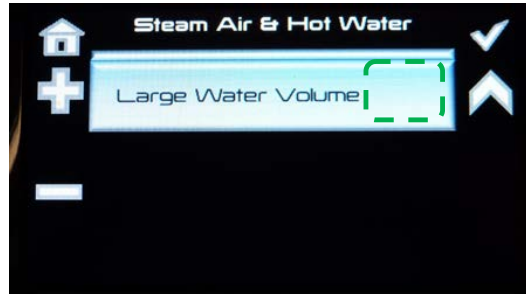
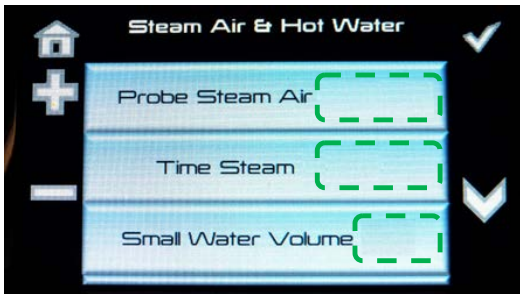

UNIC

ISO 9001

BUREAU VERITAS
Certification



Z.I. 4e RUE - BP. 425
06515 CARROS CEDEX 1 - FRANCE
Tel: (33) 04 92 08 62 60
Fax: (33) 04 93 29 24 23

www.unic.fr
info@unic.fr