

Congratulations,

By purchasing the AURELIA II you have made an excellent choice.

The purchase of a professional espresso coffee-maker involves various elements of selection: the name of the manufacturing firm, the machine's specific functions, its technical reliability, the option of immediate and suitable servicing, its price. You certainly evaluated all these factors and then made your choice: the AURELIA II.

We think you have made the best choice and after every coffee and cappuccino you will be able to assess this.

You will see how practical, convenient and efficient working with con AURELIA II.

If this is the first time you have bought a Nuova Simonelli coffee machine, welcome to high quality coffee-making; if you are already a customer of ours, we feel flattered by the trust you have shown us.

Thanks of the preference.

With best wishes,

Nuova Simonelli S.p.A.



AURELIA II

TECHNICAL CHARACTERISTICS

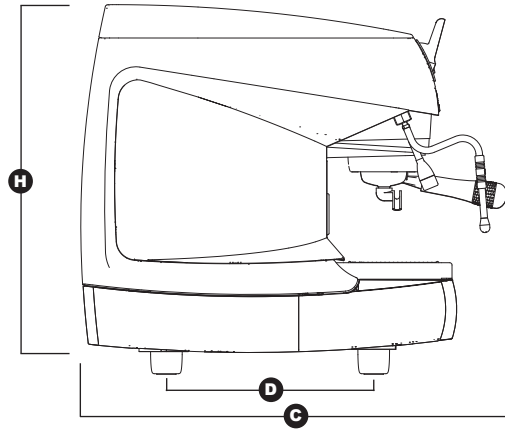
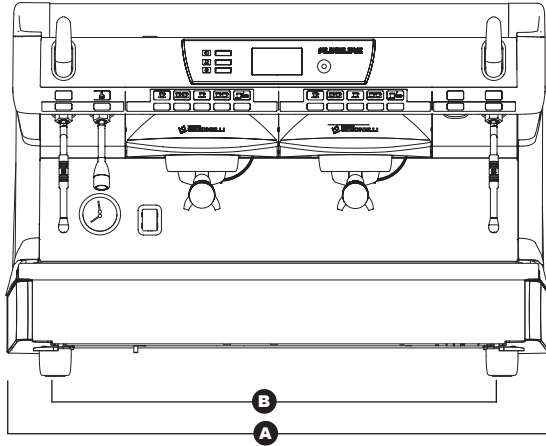

Digit Version

	2 Groups		3 Groups		4 Groups	
NET WEIGHT	74 kg	164 lb	88 kg	194 lb	102 kg	225 lb
GROS WEIGHT	80 kg	176 lb	100 kg	220 lb	115 kg	254 lb
POWER	4500 W	4500 W	5000 W	5000 W	5000 W	5000 W
DIMENSIONS	A 815 mm	A 32 1/16"	A 1045 mm	A 41 1/8"	A 1275 mm	A 50 3/16"
	B 720 mm	B 28 5/16"	B 950 mm	B 37 3/8"	B 1180 mm	B 46 7/16"
	C 565 mm	C 22 3/16"	C 565 mm	C 22 3/16"	C 565 mm	C 22 3/16"
	D 370 mm	D 14 9/16"	D 370 mm	D 14 9/16"	D 370 mm	D 14 9/16"
	H 565 mm	H 22 3/16"	H 565 mm	H 22 3/16"	H 565 mm	H 22 3/16"

T3 Version

	2 Groups		3 Groups	
NET WEIGHT	76 kg	168 lb	90 kg	198 lb
GROS WEIGHT	82 kg	181 lb	102 kg	225 lb
POWER	7300 W	7300 W	9100 W	9100 W
DIMENSIONS	A 815 mm	A 32 1/16"	A 1045 mm	A 41 1/8"
	B 720 mm	B 28 5/16"	B 950 mm	B 37 3/8"
	C 565 mm	C 22 3/16"	C 565 mm	C 22 3/16"
	D 370 mm	D 14 9/16"	D 370 mm	D 14 9/16"
	H 565 mm	H 22 3/16"	H 565 mm	H 22 3/16"

INDEX

	TECHNICAL CHARACTERISTICS	38			
1.	DESCRIPTION AURELIA II	41	7.	AURELIA T3 and DIGIT PROGRAMMING	53
1.1	CONTROL PANEL DESCRIPTION	42	7.1	KEY	53
1.2	ACCESSORIES LIST	43	7.2	PROGRAMMING (user mode)	53
2.	SAFETY PRESCRIPTION	44	7.2.1	LANGUAGE	54
3.	TRANSPORT AND HANDLING	47	7.2.2	DOSE PROGRAMMING	54
3.1	MACHINE IDENTIFICATION	47	7.2.3	SET POINT TEMPERATURE	56
3.2	TRANSPORT	47	7.2.4	KEY AND DISPLAY SETTINGS	58
3.3	HANDLING	47	7.2.5	ENERGY SAVING	60
4.	INSTALLATION AND		7.2.6	DELIVERY COUNT	62
	PRELIMINARY OPERATIONS	47	7.2.7	ALARMS	63
4.1	WATER SPECIFICATIONS	48	7.2.8	TECHNICAL SETTINGS	64
4.2	ELECTRICITY SPECIFICATIONS	48	8.	CLEANING	66
5.	ADJUSTMENTS TO BE MADE		8.1	SWITCHING OFF THE MACHINE	66
	BY A QUALIFIED TECHNICIAN ONLY	49	8.2	CLEANING THE OUTSIDE OF THE MACHINE	66
5.1	ADJUSTMENTS TO BE MADE		8.3	CLEANING THE STAINLESS COFFEE-HOLDERS	66
	BY A QUALIFIED TECHNICIAN ONLY	49	8.4	CLEANING THE UNIT WITH	
5.2	PRESSURE SWITCH (version S and V) / PUMP			THE AID OF THE BLIND FILTER	66
	(version S, V, Digit and T3) ADJUSTMENT	49	8.5	CLEANING FILTERS AND FILTER-HOLDERS	66
5.3	HOT WATER ECONOMISER ADJUSTMENT	49	9.	MAINTENANCE	67
6.	USE	50	9.1	RESIN AND SOFTENER REGENERATION	67
6.1	COMMISSIONING PROCEDURE OR				
	AFTER BOILER MAINTENANCE (T3 VERSION)	50		AURELIA II DIGIT T3 V ELECTRIC SYSTEM	101
6.2	TURNING THE MACHINE ON	50		AURELIA II DIGIT T3 S ELECTRIC SYSTEM	102
6.3	MAKING COFFEE	51		AURELIA II DIGIT V ELECTRIC SYSTEM	103
6.4	USING STEAM (Manual steam wand)	52			
6.5	MAKING CAPPUCCINO	52		AURELIA II DIGIT BOILER DIAGRAM	104
6.6	HOT WATER SELECTION	52		AURELIA II T3 (3 groups) BOILER DIAGRAM	105
6.7	AUTOSTEAM (optional)	52		AURELIA II T3 (2 groups) BOILER DIAGRAM	106
				AURELIA II T3 (2-3 groups) BOILER DIAGRAM	107

AURELIA II

1. DESCRIPTION AURELIA II

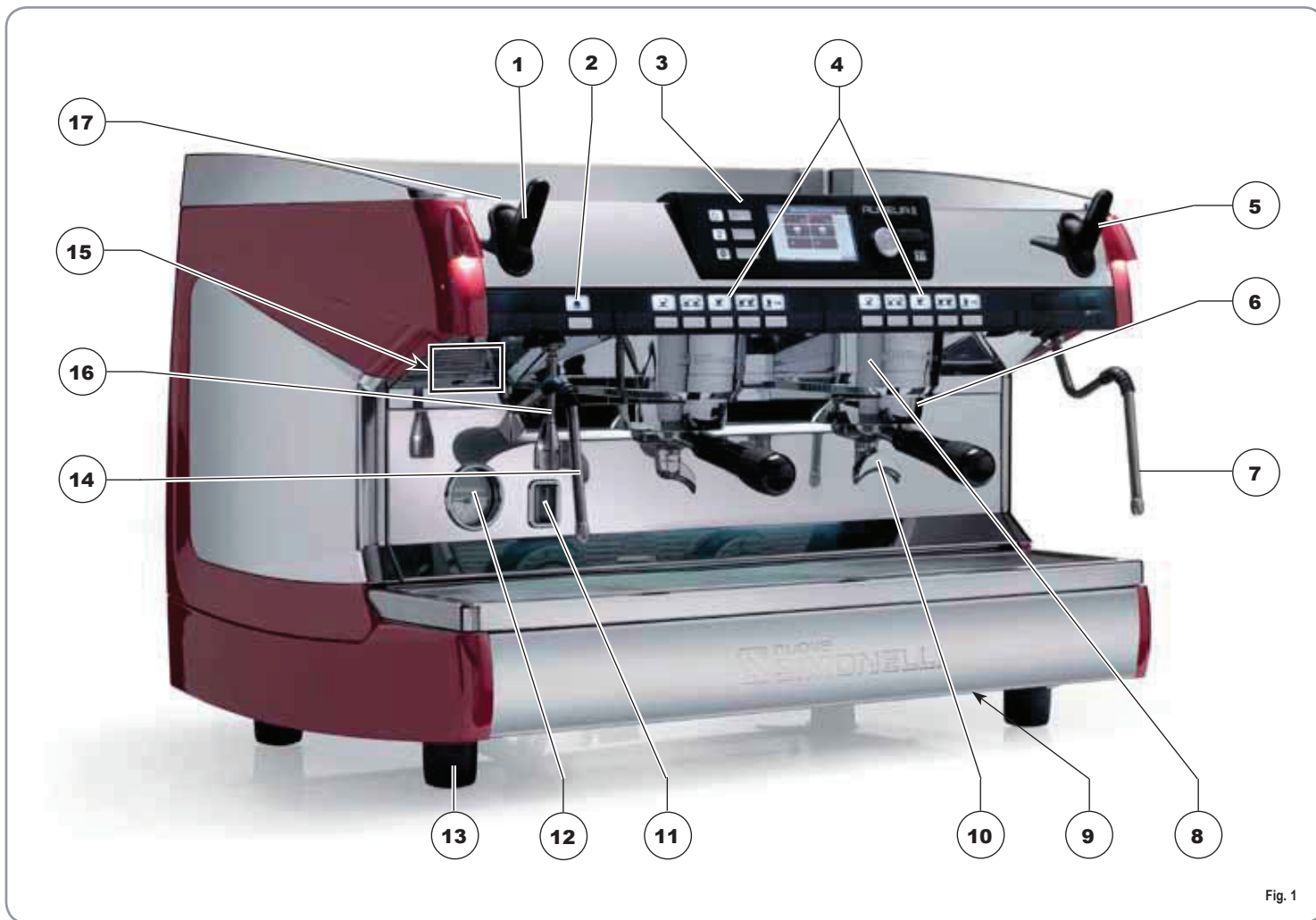

Fig. 1

KEY

- 1 Steam knob
- 2 Hot water / steam delivery button
- 3 Control panel
- 4 Coffee delivery buttons
- 5 Steam knob
- 6 Filter-holder
- 7 Manual steam nozzle
- 8 Delivery unit

- 9 Main switch
- 10 2 coffees spout
- 11 Water level inside boiler
- 12 Pressure Gauge
- 13 Adjustable foot
- 14 Manual steam nozzle
- 15 Data plate
- 16 Hot water nozzle

- 17 Electric cup warmer (optional)

ENGLISH

1.1 CONTROL PANEL DESCRIPTION

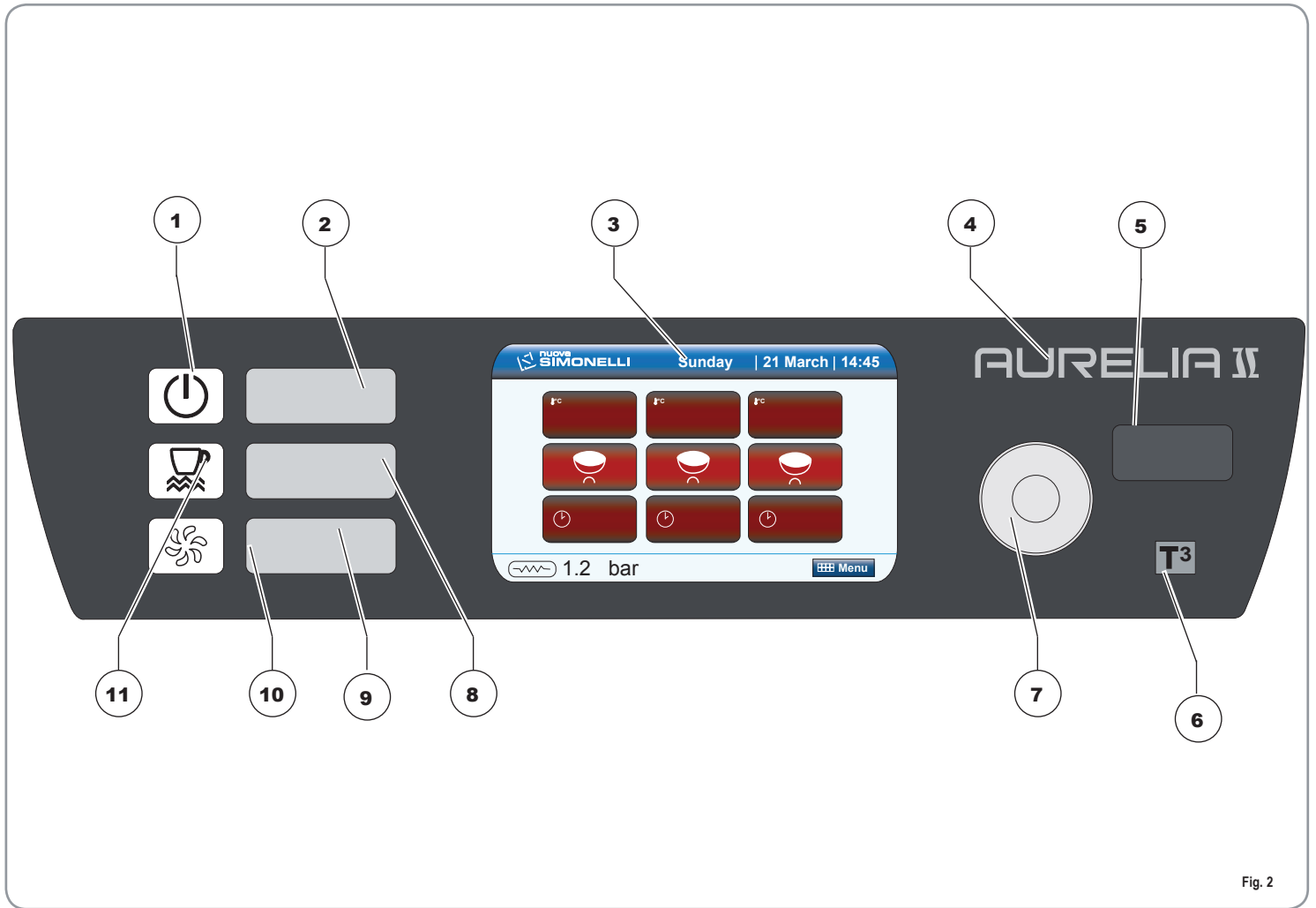

Fig. 2

KEY

- | | |
|---|---|
| <ul style="list-style-type: none"> 1 Machine On/Off light 2 Machine On/Off button 3 TFT display 4 Aurelia II Logo 5 USB port 6 Logo (T3 version) 7 Rotary switch | <ul style="list-style-type: none"> 8 Cup warmer On/Off button 9 Cup warmer On/Off button 10 Wash light 11 Cup warmer On/Off light |
|---|---|

1.2 ACCESSORIES LIST

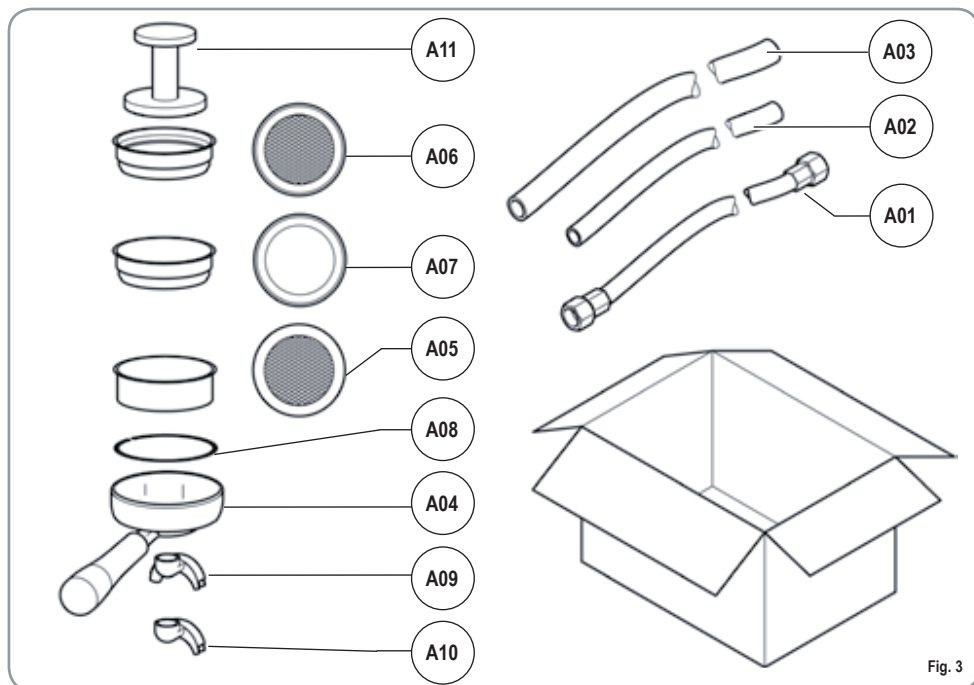



Fig. 3

CODE	DESCRIPTION	2 GROUPS	3 GROUPS	4 GROUPS (Digit only)
A01	Filling tube 3/8	1	1	1
A02	Unit tub draining tube Ø 20 mm - l. 150 cm	1	1	1
A03	Worktop draining tube Ø 25 mm - l. 150 cm	1	1	1
A04	Filter-holder	3	4	5
A05	Double filte	2	3	4
A06	Single filter	1	1	1
A07	Blind filter	1	1	1
A08	Spring	3	4	5
A09	Double delivery spout	2	3	4
A10	Single delivery spout	1	1	1
A11	Coffee presser	1	1	1

2. SAFETY PRESCRIPTION

 This book is an integral and essential part of the product and must be given to the user.

Read this book carefully. It provides important information concerning safety of installation, use and maintenance.

Save it carefully for future reference.

 The illustrations in this manual are purely for information purposes.

Your machine may differ slightly from the one shown here.

Nuova Simonelli reserves the right to make any changes to products and the manual without the need for any updates to previous products and manuals.

 After unpacking, make sure the appliance is complete.

In case of doubts, do not use the appliance, but consult a qualified technician.

Packaging items which are potentially dangerous (plastic bags, polystyrene foam, nails, etc.) must be kept out of children's reach and must not be disposed of in the environment.

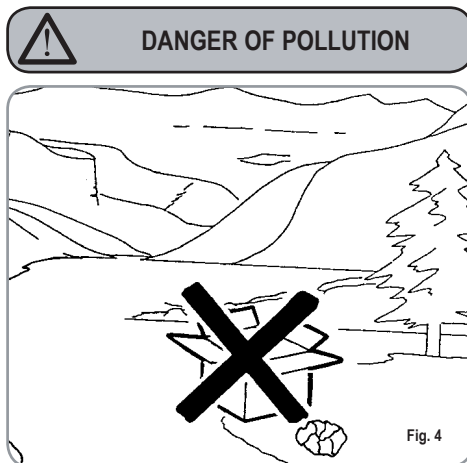

 Before connecting the appliance make sure the rating plate data correspond with the mains.

This plate is on the front panel at the top right hand side of the appliance. The appliance must be installed by qualified technicians in accordance with current standards and manufacturer's instructions.

The manufacturer is not liable for any damage caused due to failure to ground the system.

For the electrical safety of the appliance, it is necessary to equip the system with the proper grounding. This must be carried out by a qualified electrician who must ensure that the electric power of the system is sufficient to absorb the maximum power input stated on the plate.





Fig. 5

 In particular you must ensure that the size of the wiring cables is sufficient to absorb power input.

The use of adapters, multiple sockets or extensions is strictly forbidden. If they prove necessary, call a fully qualified electrician.

 For appliances powered at 220-230 V, the maximum impedance from the mains must be no higher than 0.37 Ohm.

 When installing the device, it is necessary to use the parts and materials supplied with the device itself. Should it be necessary to use other parts, the installation engineer needs to check their suitability for use in contact with water for human consumption.

 The machine must be installed in compliance with the local health standards in force for plumbing systems. Therefore, contact an authorized plumber.

 The device needs to be supplied with water that is suitable for human consumption and compliant with the regulations in force in the place of installation. The installation engineer needs confirmation from the owner/manager of the system that the water complies with the requirements and standards stated above.

 This appliance must only be used as described in this handbook. The manufacturer shall not be liable for any damage caused due to improper, incorrect and unreasonable use.

 This appliance is not suitable for use by children or persons with reduced physical, sensory or mental capabilities, or by persons with a lack of experience or knowledge, unless supervised or given instructions.

 The maximum and minimum storage temperatures must fall within a range of [-5, +50]°C.

 The operating temperature must be within the range of [+5, +35]°C.

 At the end of installation, the device is switched on and taken to rated operating conditions, leaving it in a state in which it is “ready for operation”. The device is then switched off and the whole hydraulic circuit is bled of the first lot of water in order to remove any initial impurities.

The device is then refilled and taken to rated operating conditions.

After reaching the “ready for operation” condition, the following dispensing operations are carried out:

- 100% of the coffee circuit through the coffee dispenser (for more than one dispenser, this is divided equally);
- 100% of the hot water circuit through the water dispenser (for more than one dispenser, this is divided equally);
- opening of each steam outlet for 1 minute;

At the end of installation, it is good practice to draw up a report of the operations.

 Basic rules must be observed when using any electric appliance.

In particular:

- do not touch the appliance when hands or feet are wet;
- do not use the appliance when barefoot;
- do not use the appliance when barefoot;

 **CAUTION**
RISK OF ELECTRIC SHOCK

- do not pull the supply cord out of the socket to disconnect it from the mains;
- do not leave the appliance exposed to atmospheric agents (rain, sun, etc.);
- do not let the appliance be used by children, unauthorised staff or staff who have not read and fully understood the contents of this handbook.

 During installation, the mains power system needs to be equipped with a disconnecter switch to cut off each phase.

 Before carrying out any maintenance operation, the authorised service engineer will switch off the machine and open the disconnecter.

 For all cleaning operations comply exclusively with the instructions given in this booklet.

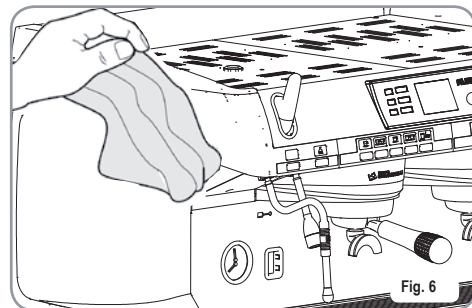



 If the appliance breaks down or fails to work properly, switch it off. Any intervention is strictly forbidden.

Repairs should only be made by the manufacturer or authorized vice centres.

Only original spare parts must be used.

Failure to observe the above, could make the appliance unsafe.

 For installation, the qualified electrician must fit an omnipolar switch in accordance with the safety regulations in force and with 3 (0,12) or more mm (in) between contacts.

 To avoid dangerous overheating, make sure the supply cord is fully uncoiled.

 Do not obstruct the extraction and/or dissipator grids, especially of the cup warmer.

 The user must not replace the appliance supply cord. If the cord is damaged, switch off the appliance and have a qualified technician change the cord.

 Single-phase appliances with current above 15 A and three-phase appliances sold without plugs are directly wired to the mains power and therefore, it is not possible to use a plug.

 If no longer using the appliance, we recommend making it inoperative; after removing the plug from the mains electricity, cut the power supply cable.

 **CAUTION**
RISK OF POLLUTION

 Do not dispose of the machine in the environment; for the disposal, contact an authorized service center or contact the manufacturer for indications.

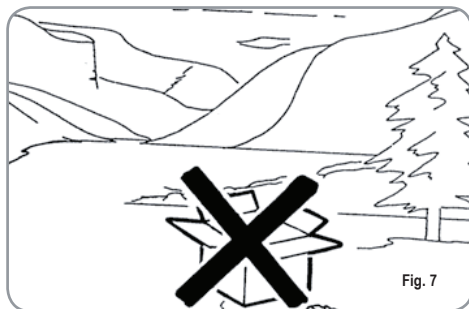

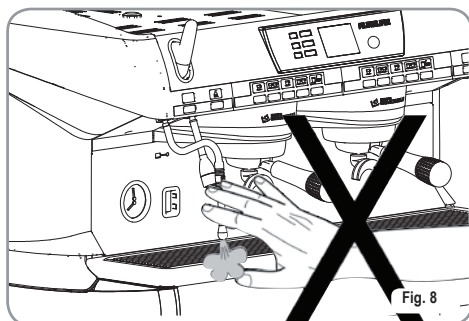

 **CAUTION**
RISK OF POLLUTION

 Use the steam nozzle with care and never place hands below the jet of steam. Do not touch the nozzle immediately after us.





 **CAUTION**
RISK OF INTOXICATION

 We remind you that before carrying out any installation, maintenance, unloading or adjustment operations, the qualified operator must put on work gloves and protective footwear.

 The maximum noise disturbance level is lower than 70db.

 If the pipe connecting to the mains water is replaced the old pipe must never be re-used.

 **CAUTION**

 **INFORMATION TO THE USERS**
Under the senses of art. 13 of Law Decree 25th July 2005, n. 151 "Implementation of the Directives/ Guidelines 2002/95/CE, 2002/96/CE and 2003/108/CE, concerning the reduction of the use of dangerous substances in electric and electronic equipment, as well as the disposal of wastes".

The symbol of the crossed large rubbish container that is present on the machine points out that the product at the end of its life cycle must Be collected separately from the other wastes. The user for this reason will have to give the equipment that got to its life cycle to the suitable separate waste collection centres of electronic and electrotechnical wastes, or to give it back to the seller or dealer when buying a new equipment of equivalent type, in terms of one to one. The suitable separate waste collection for the following sending of the disused equipment to recycling, the dealing or handling and compatible environment disposal contributes to avoid possible negative effects on the environment and on the people's health and helps the recycling of the materials the machine is composed of. The user's illegal disposal of the product implies the application of administrative fines as stated in Law Decree n.22/1997" (article 50 and followings of the Law Decree n.22/1997).

3. TRANSPORT AND HANDLING

3.1 MACHINE IDENTIFICATION

Always quote the machine serial number in all communications to the manufacturer, **Nuova Simonelli**.

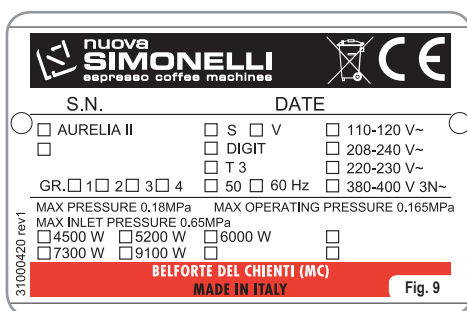

3.2 TRANSPORT

The machine is transported on pallets which also contain other machines - all boxed and secured to the pallet with supports.

Before carrying out any transport or handling operation, the operator must:

- put on work gloves and protective footwear, as well as a set of overalls which must be elasticated at the wrists and ankles. The pallet must be transported using a suitable means for lifting (e.g., forklift).

3.3 HANDLING

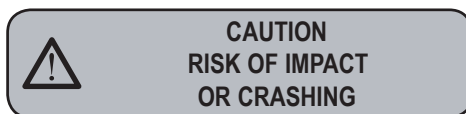

During all handling operations, the operator must ensure that there are no persons, objects or property in the handling area.

The pallet must be slowly raised to a height of 30 cm (11,8 in) and moved to the loading area. After first ensuring that there are no persons, objects or property, loading operations can be carried out.

Upon arrival at the destination and after ensuring that there are no persons, objects or property in the unloading area, the proper lifting equipment (e.g. forklift) should be used to lower the pallet to the ground and then to move it (at approx. 30 cm (11,8 in) from ground level), to the storage area.

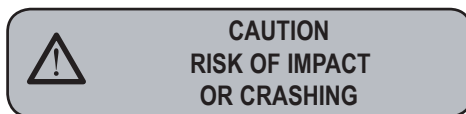

Before carrying out the following operation, the load must be checked to ensure that it is in the correct position and that, when the supports are cut, it will not fall.

The operator, who must first put on work gloves and protective footwear, will proceed to cut the supports and to storing the product. To carry out this operation, the technical characteristics of the product must be consulted in order to know the weight of the machine and to store it accordingly.

4. INSTALLATION AND PRELIMINARY OPERATIONS

After unpacking, assess that the machine and its accessories unit are complete, then proceed as follows:

- place the machine so that it is level on a flat surface;
- assemble its supporting feet by inserting the insert into the cylindrical unit;
- twist the rubber foot into the screw thread inside the unit;
- screw the whole assembled unit into the allotted setting for the machine's adjustable feet;
- level the machine by regulating the adjustable feet;

NOTE: the unit grooves have to face upwards, as shown in the following illustration.

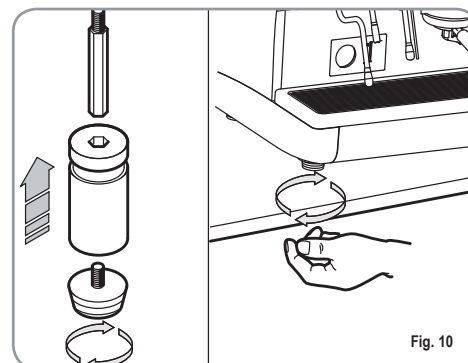

It is advisable to install a softener (1) and then a mesh filter (2) on the external part of the plumbing system, during preliminaries and after levelling the machine.

In this way impurities like sand, particles of calcium, rust etc will not damage the delicate graphite surfaces and durability will be guaranteed.

Following these operations, connect the plumbing systems as illustrated in the following figure.

WARNING

Avoid throttling in the connecting tubes. Assess that the drain pipe (3) is able to eliminate waste.

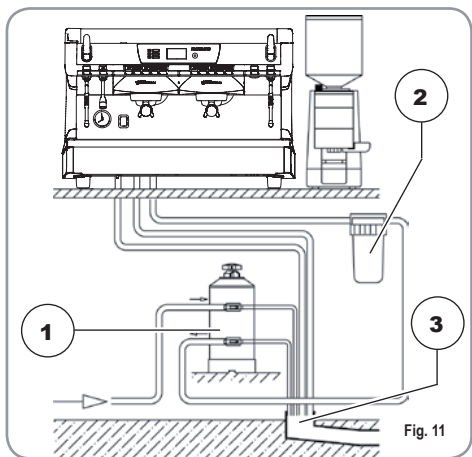

- KEY**
- 1 Softener
 - 2 Mesh filter
 - 3 Drain Ø 50 mm

4.1 WATER SPECIFICATIONS

Monitoring of water recipe to keep it within required levels and maintenance of filtration system is the user's responsibility.

Failing to meet and maintain water at the following levels will void the entire warranty:

- total hardness 50-60 ppm (parts per million)
- water line pressure between 2 – 4bar and water to be cold

- min flow rate: 200 l/hr
- filtration level below 1.0 micron
- tds (total dissolved solids) level between 50 – 250 ppm
- alkalinity level between 10 – 150 ppm
- chlorine level less than 0.50 mg/l
- Ph level between 6.5 and 8.5.

4.2 ELECTRICITY SPECIFICATIONS

CAUTION RISK OF SHORT CIRCUITS

The machine must always be protected by an automatic omnipolar switch of suitable power with contact openings of equal distance or more than 3mm.

Nuova Simonelli is not liable for any damage to people or objects due to not observing current security measures.

Prior to connecting the machine to the electrical mains, assess that the voltage shown on the machine's data plate corresponds with that of the mains.

If it does not, carry out the connections on the basis of the available electrical line, as follows:

- for V 230 / monophase voltage

- for V 230 / monophase voltage

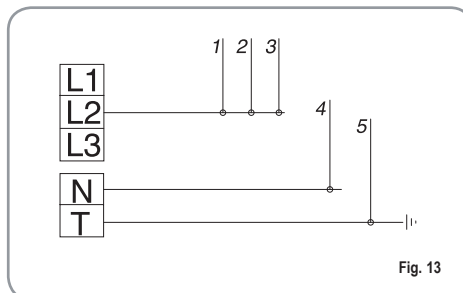

- KEY**
- | | |
|---------|----------------|
| 1 Black | 4 Blue |
| 2 Grey | 5 Yellow-green |
| 3 Brown | |

NOTE: At the start of the day's activities and in any case, if there are any pauses of more than 8 hours, then it is necessary to change 100% of the water in the circuits, using the relevant dispensers.

NOTE: In case of use where service is continuous, make the above changes at least once a week.

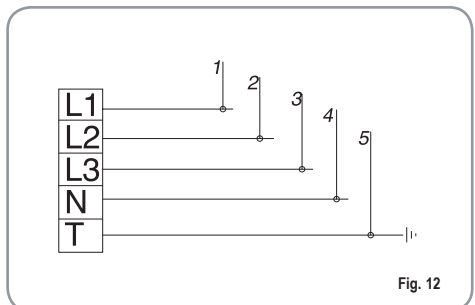

5. ADJUSTMENTS TO BE MADE BY A QUALIFIED TECHNICIAN ONLY

5.1 ADJUSTMENTS TO BE MADE BY A QUALIFIED TECHNICIAN ONLY

NOTE: this operation must be carried out with the machine turned off.

All models AURELIA II are equipped with a level gauge to keep the water level inside the boiler constant. When using the machine for the first time, it is advisable to fill the boiler by hand to avoid damaging the electrical resistor and turning on the electronic protection.

If this should happen, just turn the machine off and then start it up again to complete its loading procedure (see "MACHINE OPERATION MESSAGES").

To fill the boiler manually for the first time, proceed as follows

- remove the worktop grid;
- use the manual level cock "A" to allow water to enter the boiler;
- once the maximum level has been reached, as indicated by the optical level, turn tap "A" off;

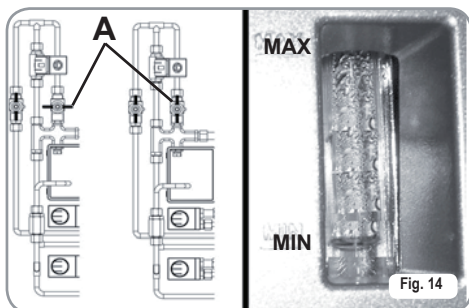

- switch the machine on by placing the general switch on "I"; this will activate the level gauge which will automatically maintain the water level inside the boiler.

5.2 PRESSURE SWITCH (version S and V) / PUMP (version S, V, Digit and T3) ADJUSTMENT

NOTE: this operation can be carried out while the machine is turned on.

All models AURELIA II are fitted with a hot water mixer, which serves to adjust the temperature of the water leaving the wand and to optimise system performance.

To set the hot water economy device, use a screwdriver on the screw in the top part of the machine, as shown in the figure.

- Turn it CLOCKWISE / ANTICLOCKWISE to REDUCE / INCREASE the temperature of the hot water;

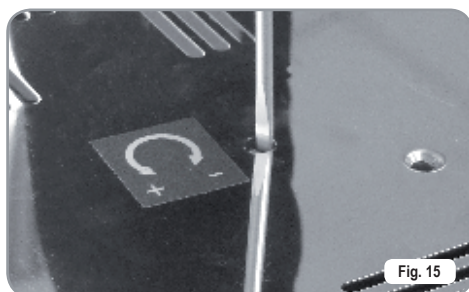



5.3 HOT WATER ECONOMISER ADJUSTMENT

The electronic control unit has a lithium battery to power the clock; the battery has an autonomy of about three years, after which it will need to be replaced.

In case of an extended period of machine stoppage, the clock can be stopped:

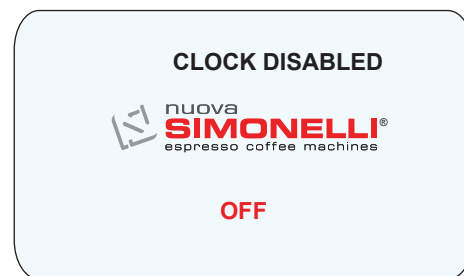
- with the machine off the display will read:



- hold the ON/OFF key down  for 5 sec. to release the clock.



Replacement of the lithium battery must be carried out **EXCLUSIVELY** by Qualified Technician.



Nuova Simonelli cannot be held liable for any damage to people or things due to non observance of the safety prescriptions described in this booklet.

6. USE

Before starting to use the appliance, the operator must be sure to have read and understood the safety prescriptions contained in this booklet.

6.1 COMMISSIONING PROCEDURE OR AFTER BOILER MAINTENANCE (T3 VERSION)

When commissioning the machine for the first time or after carrying maintenance switch ON the machine using the main switch positioned lower down and on the right and proceed as follows:

- 1) If the message "OFF – CLOCK DISENABLED" appears on the display proceed as follows in step three.
- 2) If the display reads "OFF" press the ON/OFF  key until it reads "OFF –CLOCK DISABLED" and then proceed as described in step 3.
- 3) Switch on the machine using the ON/OFF  key and automatically after the machine has switched on, some water will be poured from the groups for about 45 seconds to make sure that the coffee boiler tanks have been properly filled.
This cycle cannot and must not be interrupted.
If this cycle is interrupted due to a power outage or if the machine is accidentally switched off from the main switch, the next time the machine is switched on, the cycle will be started again for approximately 45 seconds more.

6.2 TURNING THE MACHINE ON

SWITCH ON: plug the machine into the power socket and press the switch "A" so it is in position "I"; the machine will switch on. Pressing the switches "B" and "C" in the "I" position will switch on the LEDs, independently of the position of switch "A".

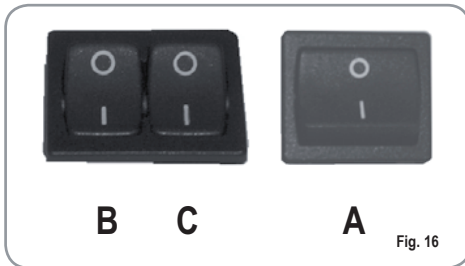

If the self-diagnostics report anomalies or failures, the operator MUST NOT intervene. Please contact the Assistance Centre.

- The lit display will show the firmware version for about 1 second:



- The display, which is not illuminated, will read:



NOTE: The machine is not operational, since the main switch only powers the electronic card.



For electronic card maintenance, turn the machine off by means of the external main switch or disconnect the plug.

MANUAL SWITCHING ON/OFF

Automatic On/Off NOT PROGRAMMED

NOTE: make sure that the general switch is always on the position "I".

SWITCH ON: press the On/Off button  for about 2 seconds until the light switches on and the buzzer makes a beep sound. The control unit will start up an auto diagnosis cycle to check the functions, all the selection keys will light up.

After the diagnostics stage, the "Home Page" will open on the screen:

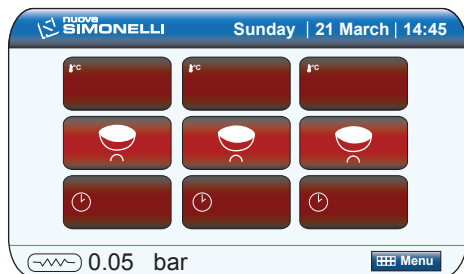

NOTE: on completion of the check up all the selection keys are activated.



WARNING

In case the auto diagnosis indicates error or malfunction, call an assistance centre; the operator **MUST NOT** intervene.

SWITCHING OFF: press the ON/OFF button  for about 2 seconds, until the light switches off. The machine will switch off and the display will read:



Automatic On/Off PROGRAMMED

NOTE: make sure that the general switch is always on the position "I".

The machine will **SWITCH OFF** at the first time set for stopping the coffee maker (see the **PROGRAMMING** chapter and the **ENERGY SAVING** section).

The control unit will perform an auto diagnosis of all functions and all of the selection keys will light up.

After the diagnostics stage, the "Home Page" will open on the screen:



NOTE: once the auto diagnosis has been completed all the keys are activated.



WARNING

If the self-diagnostics report anomalies or failures, the operator **MUST NOT** intervene. Please contact the Assistance Centre.

The machine will **SWITCH ON** at the first programmed switch-on time (see the **PROGRAMMING** chapter and the **ENERGY SAVING** section).

NOTE: the machine can be switched on or off manually as indicated in the previous paragraphe.

6.3 MAKING COFFEE

Unhitch the filter-holder and fill it with one or two doses of ground coffee depending on the filter used.

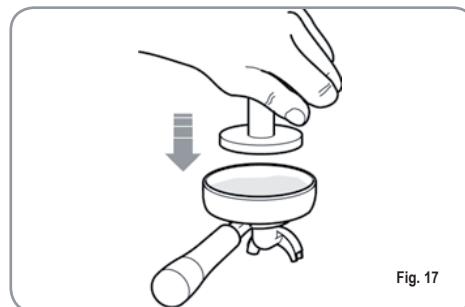

Press the coffee with the provided coffee presser, dust off any coffee residue from the rim of the filter (this way the rubber gasket will last longer).

Insert the filter in its unit.

Press the desired coffee button.

NOTE: when in pause, leave the filter-holder inserted in the unit so that it will keep warm.

To guarantee the utmost thermic stability during use, the delivery units are thermo-compensated with complete hot water circulation.

6.4 USING STEAM (Manual steam wand)



CAUTION
RISK OF BURNS OR SCALDING

While using the steam nozzle, you must pay attention to not place your hands beneath it or touch just after it has been used.

To use the steam function, pull or push the relevant lever, as shown in the figure.

By pulling it completely the lever will hold a position of maximum delivery; by pushing it, the lever will automatically give way.

The two steam nozzles are articulated to guarantee their easy use.

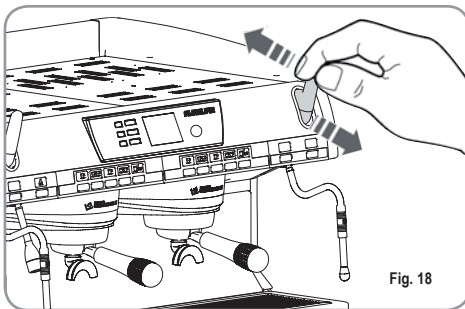

Fig. 18

NOTE: Before using the steam wand, always bleed out any condensation for at least 2 seconds or according to the manufacturer's instructions.

6.5 MAKING CAPPUCCINO

To obtain the typical cappuccino foam, immerse the nozzle all the way into a container 1/3 full of milk (preferably cone-shaped). Turn on the steam. Before the milk starts to boil, pull the nozzle slightly up and lightly move it vertically across the surface of the milk. When you have completed the procedure, clean the nozzle carefully with a soft cloth.

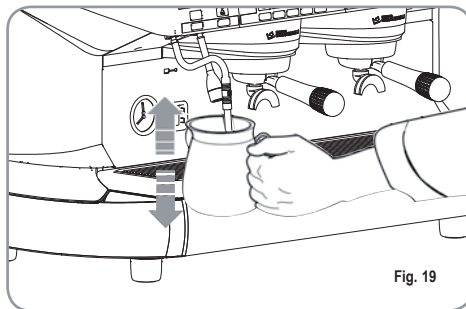

Fig. 19

6.6 HOT WATER SELECTION



CAUTION
RISK OF BURNS OR SCALDING

While using the hot water nozzle, pay careful attention not to place your hands beneath it or touch it just after it has been used.

This nozzle delivers hot water to make tea or herb teas.

Place a suitable container under the hot water nozzle. Press the hot water select button once;

the light  will switch on.

The hot water wand will deliver water for the amount of time equivalent to the set value (see PROGRAMMING section and the DOSE PROGRAMMING section) or press the button again to stop pouring.

NOTE: Hot water can be delivered at the same time as coffee.

6.7 AUTOSTEAM (optional)

CAUTION
RISK OF BURNS OR SCALDING

When using autosteam, take great care not to place your hands underneath it and never touch it immediately afterwards.

This serves to deliver steam and the temperature is controlled by a probe. The temperature is set during the programming stage.

To enable autosteam, press the steam button



; the light will switch on.

The steam delivery will stop as soon as the set temperature for the liquid is reached.

NOTE: Steam can be delivered at the same time as coffee.

7. AURELIA T3 and DIGIT PROGRAMMING

7.1 KEY

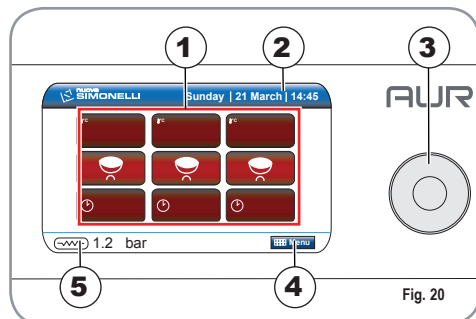

Fig. 20

Nr.		Description
1		Interactive programming / viewing area.
2		DATE and TIME
3		ROTARY SWITCH: Turn to move through the interface. When the icon is selected, it changes colour and lights up white; press to enable the selected function/icon. Programming also makes it possible to increased and/ or reduce settings.
4		MENU ICON To open the main menu and return back a level during navigation.
5		HOME ICON: To return to the "Home Page" while navigating through the interface.

7.2 PROGRAMMING (user mode)

Switch on the machine as described in the "Use" chapter – the "Switching the machine On/ Off" section. The display shows the "Home Page".

Group temperatures (T3 version only, if enabled during programming)

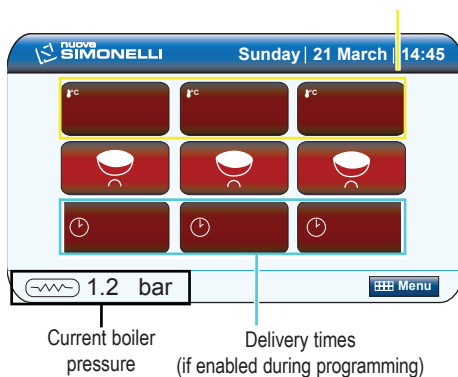

Select and press the rotary switch to access the main menu.

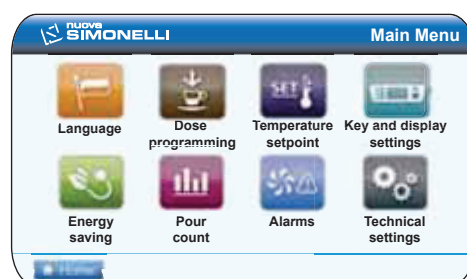

Icon	Description
	Language.
	Dose programming.
	Setpoint temperature and group/boiler offset.
	Key and display settings.
	Energy saving.
	Delivery counts.
	Alarms.
	Technical settings.

7.2.1 LANGUAGE

Use the rotary switch to move to the "Language" icon. Press the icon to open:



This shows the page for selecting the language for the whole interface.



Use the rotary switch to move within the screen and press to confirm the language selection.

7.2.2 DOSE PROGRAMMING



Use the rotary switch to move to the "Dose Program." icon and press to open:



3 options will be displayed:



Icon	Description
	Programming single doses.
	Dose transfer between groups.
	Standard dose setting.

Use the rotary switch to select one of the three options and then press to access.

DOSE PROGRAMMING

The display will show:

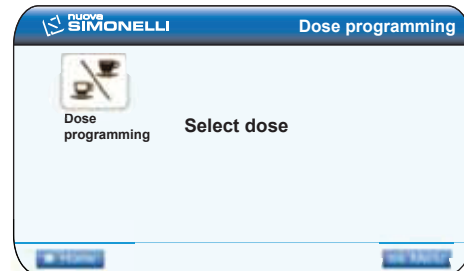

Select the icon again with the rotary switch and press.

All programmable keys will start to flash:

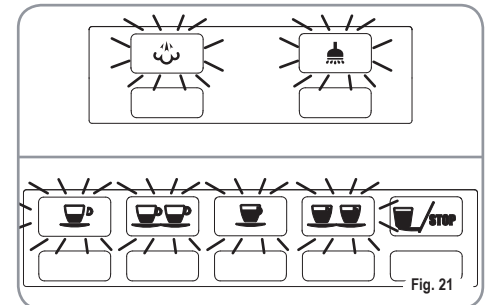

Coffee:

Press the button to be programmed; the display will show the icon for the selected button and the setting already programmed.

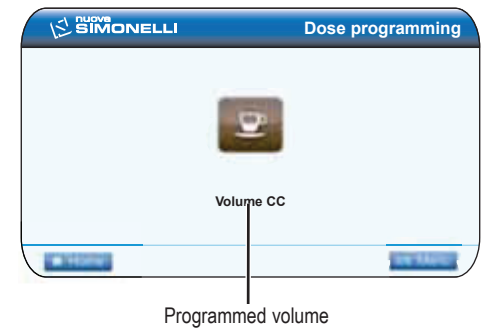

It is possible to change the dose using the rotary switch and then pressing it to confirm the setting. Or, press the coffee key to programme, the delivery will start and in the meantime, all of the other lights will switch off.

Once the required dose has been poured, press the continuous coffee button to stop delivery.

- The display will show the new value and it will still be possible to change it using the rotary switch.
- Press the rotary switch in any case to confirm the programmed dose.
- The coffee button that has been programmed is then switched off by pressing the rotary switch.

To continue programming the different keys, select the icon with the rotary switch and press on it.



Hot water:

Press the hot water button to be programmed; the display will show the icon for the chosen function and the programmed setting.

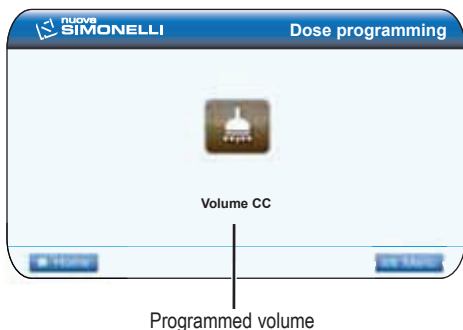

It is possible to change the dose using the rotary switch and then pressing it to confirm the setting.

Or, press the hot water key to programme, the delivery will start and in the meantime, all of the other lights will switch off.

Once the required dose has been poured, press the hot water button to stop delivery.

- The display will show the new value and it will still be possible to change it using the rotary switch.

- Press the rotary switch in any case to confirm the programmed dose.
- The hot water button that has been programmed is then switched off by pressing the rotary switch.

Autosteam (optional):

Press the steam button and make sure that the button lights up:



Set temperature

It is possible to change the temperature using the rotary switch and the press to confirm the setting. Or, press the steam key to programme, the delivery will start and in the meantime, all of the other lights will switch off.

Once the required temperature has been reached, press the steam button to stop delivery.

- The display will show the new value and it will still be possible to change it using the rotary switch.
- Press the rotary switch in any case to confirm the set temperature. The programmed steam button switches off when the rotary button is pressed.

DOSE TRANSFER

This function serves to transfer the value of the programmed dose settings to other groups. Select the group to be used as a "source" and confirm:



Select the "destination" group for the copy of the settings and confirm

NOTE: The group used as a source is uninhibited.



STANDARD DOSES

This function serves to recall the "Standard dose" settings for groups.

The display shows:

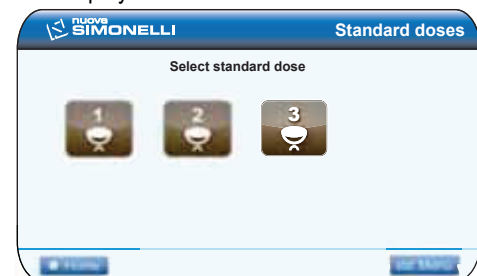

Select the coffee unit to apply the "standard dose" settings and press the rotary switch to confirm.



7.2.3 SET POINT TEMPERATURE

Use the rotary switch to move to the "Set point temperature" and press to enter:



4 options will be displayed:



Icon	Description
	Group setpoint (T3 version only).
	Setpoint caldaie (solo versione T3).
	Steam boiler setpoint.
	Cup warmer.

GROUP SETPOINT (T3 version only)

The display will show:



Use the rotary switch to select the coffee group to adjust and confirm by pressing.

Group 1 example:

Setting programmed / to be programmed



Instant setting

Turn the rotary switch to select the required temperature for the group, then press to confirm.

GROUP OFFSET ADJUSTMENT:

From the screen:





Hold down the washing key  to access offset and group temperature adjustment. The next screen will be:



With the rotary switch it is possible to select the group offset to be adjusted and press to proceed.

Use the rotary switch to adjust the value of the group offset and then confirm with by pressing the switch.

At this point, it is possible to adjust the offset of the other groups with the same procedure or to select  Menu or  Home.

This setting is reserved to qualified service engineers.

BOILER SETPOINT (T3 version only):



The display shows:

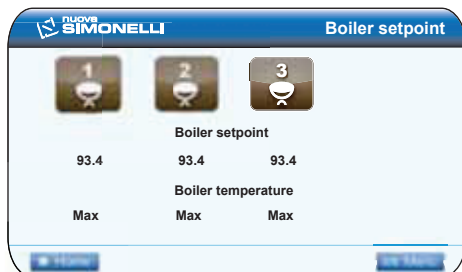

Select the coffee boiler to be adjusted and confirm by pressing the rotary switch.

Boiler 1 example

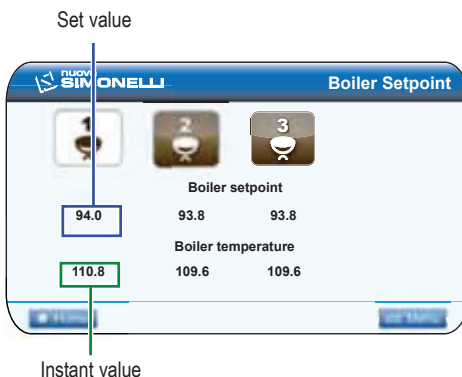

Turn the rotary switch to select the required temperature for the group; press it to confirm the setting.

BOILER OFFSET ADJUSTMENT:

From the screen:

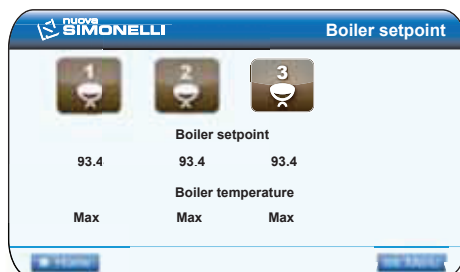

Hold down the washing key to access offset and boiler temperature adjustment.

The next screen will be:



Use the rotary switch to select the coffee boiler for offset adjustment and press it to proceed. Also use the rotary switch to set the offset value for the group and then press the switch to confirm.

At this point it is possible to adjust the offset of other groups with the same procedure or select **Menu** or **Home**.

This setting is reserved to qualified service engineers.

STEAM BOILER SETPOINT:



The display shows:



Select the steam icon and confirm with the rotary switch.

Set value



Instant value

Turn the rotary switch to select the required pressure / temperature for the boiler (see the table on the following page) and then press the switch to confirm the setting.

PRESSURE-TEMPERATURE TABLE

Bar	°C	°F
0,50	110,5	230,9
0,55	111,5	232,7
0,60	112,5	234,5
0,65	113,5	236,3
0,70	114	237,2
0,75	115	239
0,80	115,5	239,9
0,85	116,5	241,7
0,90	117,5	243,5
0,95	118	244,4
1,00	119	246,2
1,05	119,5	247,1
1,10	120,5	248,9
1,15	121	249,8
1,20	122	251,6
1,25	122,5	252,5
1,30	123	253,4
1,35	124	255,2
1,40	124,5	256,1
1,45	125	257
1,50	126	258,8
1,55	126,5	
1,60	127	

CUP WARMER 

The display will read:

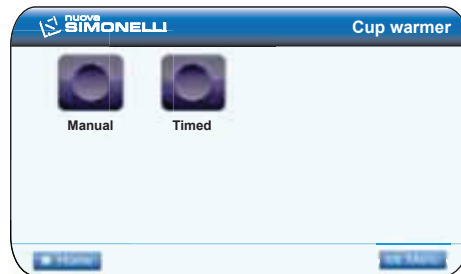

To work in "manual" mode, select the icon



Manual (Manual) with the rotary switch and press:

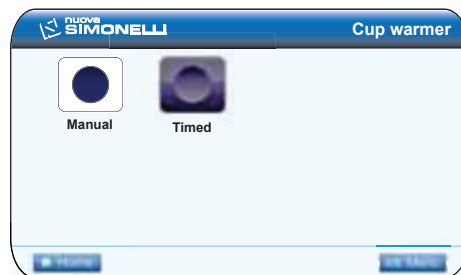

To work in "timer" mode, select the timer icon



Timed (Timed) with the rotary switch and press it.

The following screen will open:



Use the rotary switch to edit the ON and OFF times and then press to confirm.

7.2.4 KEY AND DISPLAY





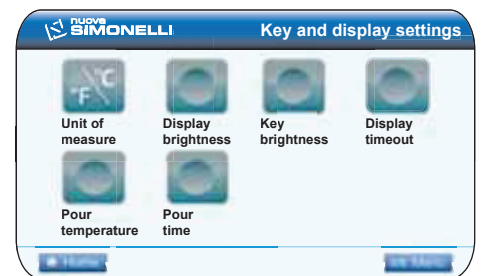

SETTINGS 

Use the rotary switch to move to the "Button and display setting" and press to open:



6 options will be displayed:



Icon	Description
	Unit of measurement
	Display brightness
	Button brightness
	Display timeout
	Delivery temperature
	Delivery time

UNIT OF MEASURE

This screen serves to change the unit of measure for the temperature used to control the whole interface:

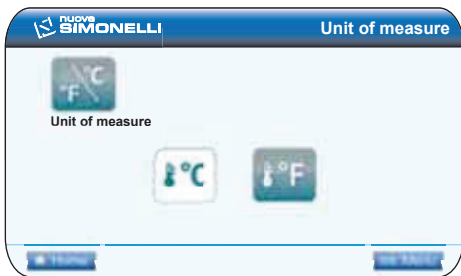

Use the rotary switch to select and press it to confirm.

DISPLAY BRIGHTNESS

This function serves to adjust the standard brightness of the display:



Use the rotary switch to choose the level and press it to confirm.

BUTTON BRIGHTNESS

Use this function to set the brightness of the keys:



Use the rotary switch to choose the level and press it to confirm.

DISPLAY TIME OUT

Use this function to set the display "Time-out" time (low-brightness display). Example. Set to 5 min, if the machine is not used for more than 5 minutes, the display brightness will be reduced. The brightness will return to normal as soon as the machine is used again.



Use the rotary switch to choose the time (minutes) and press to confirm.

DELIVERY TEMPERATURE

(T3 version only):

This function serves to activate/deactivate the display for the group delivery temperature on the "Home Page":



Use the rotary switch to select / and press to confirm.

DELIVERY TIME

This function serves to activate/deactivate the display for the delivery time on the "Home Page"



If you decide to view the delivery time , use the rotary switch to select from the following options:

- Timer (vanishes after 5 sec.);
- Persistent (remains on the display until the next coffee).



After selecting the option with the rotary switch, confirm by pressing.

7.2.5 ENERGY SAVING



Use the rotary switch to select the "Energy saving" icon and press to open the function:



This shows 3 options:



Icon	Description
	Weekly schedule.
	Active groups.
	Standby active.

WEEKLY PROGRAMMING

This page serves to set the days off for the machine and the days in which its automatic switch on and off functions are programmed. When the page is opened it will show the configuration of the first day of the week (Monday). Turn the rotary switch to view the configuration for the days until the last day of the week, after which select with the **Menu** and **Home** icons.

The operation is cyclical.

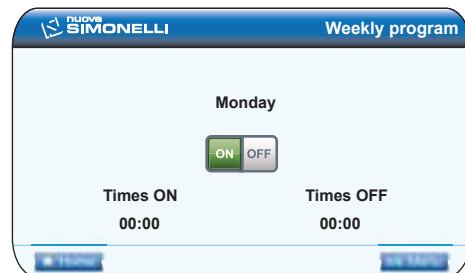

To change the configuration for one day, this day must be shown on the display and then the rotary switch must be pressed.

At this point, an icon will be selected to signal if that day there is a programmed switch on or off time () or not ().

Programmable day example:

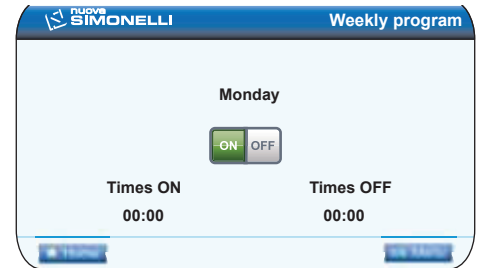

OFF day example:



To save changes, press the rotary switch. At this point, the day is active, the hours will start to flash for the ON time.

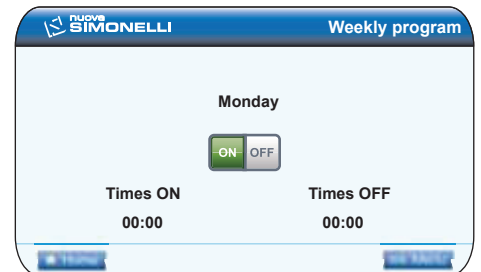

Turn the rotary switch to view and change the setting.

Turn the rotary switch to view and change the setting.

Press the rotary switch to store the setting and pass on to change the minutes for the ON time. The previous procedure is repeated with minutes and hours for the ON and OFF times.

Once the minutes have been saved for the OFF

time, the machine returns to the initial condition where, by turning the rotary switch, it is possible to view the settings for the different days of the week, home and menu.

it is possible to view the settings for the different days of the week, home and menu.

ACTIVE GROUPS

This function serves to set the groups that are actually active when the machine is switched on:

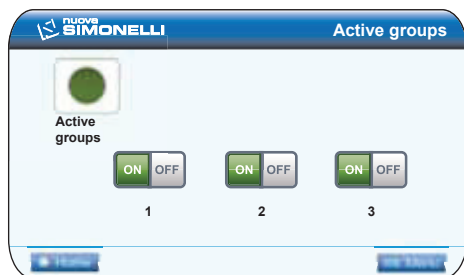

To set the active groups when the machine is switched on, proceed as follows:

- Access the function by pressing the rotary switch on the active group icon.
- It is possible to activate/deactivate individual groups using the rotary switch. Press the rotary switch to confirm and pass on to the next group. Confirming the last group will return to the menu.
- Press the icon  to go back to the home page.

NOTE: To make the change effective, it is necessary to quit the programming mode, switch the machine on and off from the main switch, which is located in the bottom right.

When the deactivated group is switched back on, its colour will be darker and the group will no longer be operational (e.g. group 1 deactivation).

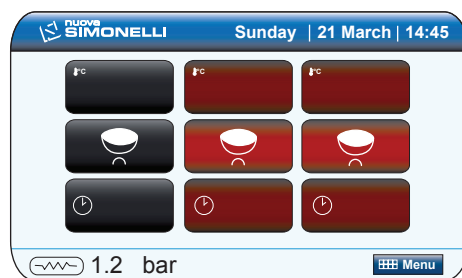



The change is permanent and can only be cancelled following the same procedure as used to enable it.

It is also possible to deactivate the groups without entering the programming mode.

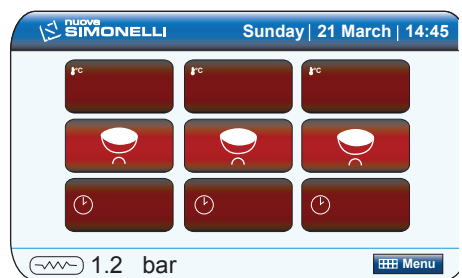
From the following stand-by screen:



Press the button  and coffee key together  in case of the S version, or the long coffee key  on the V version; the corresponding group will be disabled, causing the display to read (E.g. group 1 de-activated):

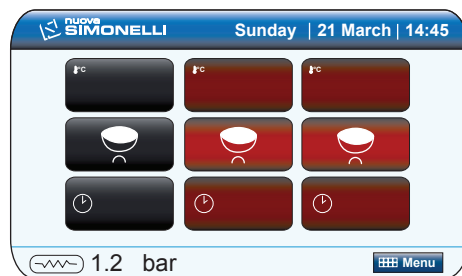

The change is not permanent in that every time it is switched on from the main switch, all of the groups will be active.

NOTE: The change is not permanent in that every time it is switched on from the main switch, all of the groups will be active.

NOTE: If a group is disabled, it is not possible to make any deliveries and the boiler heating elements will be switched off.

ACTIVE STANDBY

This function allows the machine to enter standby mode or not, which makes it possible to choose whether or not to switch off the machine completely or to keep it at a set pressure (less than working levels).

Use the rotary switch to select the following options:

- **OFF:** during the OFF state, the machine is completely switched off and the display reads "OFF"

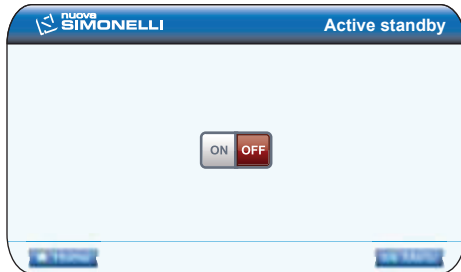

- **ON 0.10 bar:** during the OFF state, the machine maintains a pressure of 0.10 bar and the display (set to minimum brightness) reads "LOW CONSUMPTION".

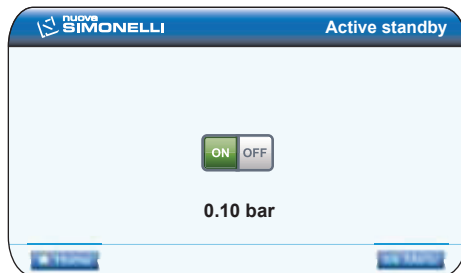

- **ON 0.50 bar:** during the OFF state, the machine maintains a pressure of 0.50 bar and the display (set to minimum brightness) reads "LOW CONSUMPTION".

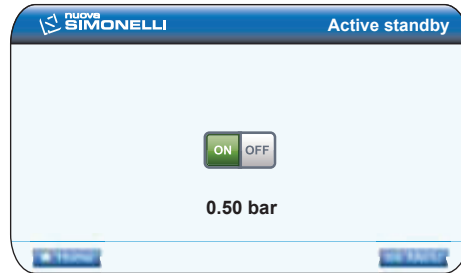

- **ON 0.80 bar:** during the OFF state, the machine maintains a pressure of 0.80 bar and the display (set to minimum brightness) reads "LOW CONSUMPTION"

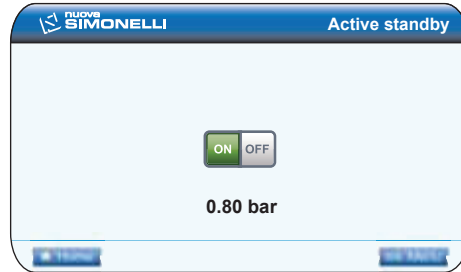

Press the rotary switch to confirm the required option.

This operation is used with both manual switching on/off using the button , and automatic switching on/off by programming the machine.

If the on/off button , is pressed during one of the three active standby states (0.10 bar, 0.50 bar, 0.80 bar), the machine will switch off completely.

If the button is pressed again, this will switch on the machine.

7.2.6 DELIVERY COUNT

Use the rotary switch to move to the "Delivery count" icon and press to open:



A screen will open to view the counters:

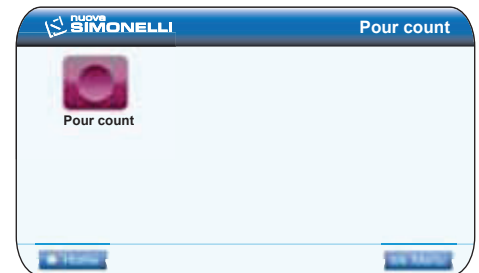

Select the delivery counter icon  and press the rotary switch.

On the counter page, it is possible to view 2 tables that show the counters; to pass from one to the other, use the rotary switch.

The first table shows the counts for the single doses of each group:

				
	5	0	0	
	0	0	0	
	0	0	0	
	0	0	0	
Continue	1	0	0	

The second table shows the total for groups, washing, services and absolute total:

	+	+	+	
Total grp	6	6	6	
Washes	7	1	2	
Total				
18	4	1		

The different fields in the two tables can be deleted using the delete mode.

The delete mode is entered by pressing and holding down the wash button for a few seconds.

Once in this mode, the table will contain a red rectangle showing the value that can be deleted. Use the rotary switch to select the field to be deleted and press the rotary switch again to delete it.

	+	+	+	
Total grp	6	6	6	
Washes	7	1	2	
Total				
18	4	1		

To quit the delete mode, press the wash button again.

To quit the count mode, press the rotary switch again and then select **Menu** or **Home**.

7.2.7 ALARMS

Use the rotary switch to select "Alarms" and press to open:



Two options will be displayed:



Icon	Description
	Alarm history
	Wash alarms

ALARM HISTORY

This function serves to view the history of control unit alarms:

Error found
Cup warmer probe 1 error
Pressure error
Group dose error 1
Group dose error 2
Group dose error 1

Turn the rotary switch to navigate through the two pages with the list of errors stored in the control unit.

To delete the alarm history, press the wash button on the control panel and hold it down for 3 seconds.

To quit, press the rotary switch again and then select **Menu** or **Home**.

WASH ALARMS:

This function serves to set the timer (hours and minutes) for the group wash alarm.

E.g. setting 1 h and 30 min., will cause the machine to send a wash alarm message after 1h and 30 min.

It is possible to access this function pressing the rotary switch. Use the rotary switch to select from the ACTIVE and NON ACTIVE modes.

Selecting NON ACTIVE using the rotary switch will return to the main menu.

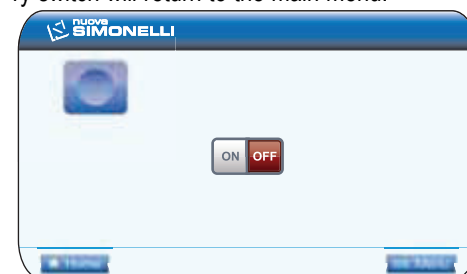

Selecting ACTIVE it is then necessary to use the rotary switch to set the hours and minutes after which the alarm message appears.

After the minutes have been set, the machine returns to the main menu.





7.2.8 TECHNICAL SETTINGS

Use the rotary switch to highlight the "Technical settings" icon and press to open:



The display will show the 5 options:



Icon	Description
	Date and time.
	Information.
	Firmware update.
	Maintenance.
	Automatic wash cycle.

DATE AND TIME

This function serves to change the date and time setting for the machine and it is viewed from the "Home Page".



Once the icon has been selected with the rotary switch, press it to access the change mode for the year, month, day, hour and minutes. After the minutes have been set, the machine returns to the main menu.

INFORMATION

This function serves to view the main information about the machine and the software.

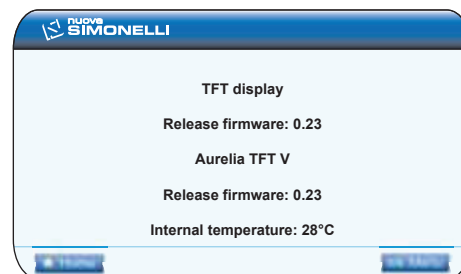

FIRMWARE UPDATE:

This screen is used to update the firmware inside the machine. Follow the procedures described on the display and use the special USB socket in the control panel.

MAINTENANCE

This function serves to set scheduled maintenance.

It is possible to programme the number of deliveries and the date after which the maintenance alarm will be enabled.

The alarm is triggered when the hour counter or date is reached.

The machine will continue to operate as normal.

Select the icon with the rotary switch and press it. The number of deliveries will start to flash.

Number of deliveries

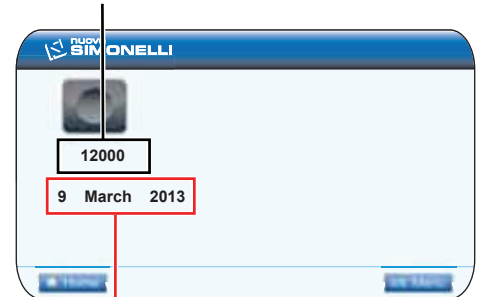

Maintenance date

Change the number of deliveries with the rotary switch and press to confirm.

Use the same method to change the day, month and year for the maintenance date.

Once the year has been changed, the machine will return to the main menu.

Once the changes have been made, to make them effective, it is necessary to exit the programming mode, and then switch the machine off and then on again from the main home page.

AUTOMATIC WASH CYCLE

This function serves to carry out an automatic wash cycle for the groups.

NOTE: It is possible to open the wash function by pressing the wash button .

Insert the blind filter in the portafilter, add half a dose of Pulicaff and insert the portafilter into the group to be cleaned automatically



Use the rotary switch to select the group to be washed and press the switch:



The machine views:



The cycle will start automatically for the group.

It is possible to select one of the other groups. At the end, select  or  to exit.

In this case, the screen will display (E.g. Wash group 1 only):

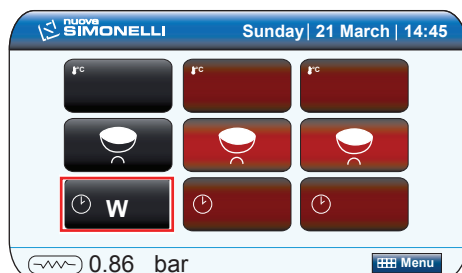

Once the washing has been finished, the rinse stage is requested automatically:

The washing button  will start to flash; press it and the machine will display:



Empty the blind filter of any Pulicaff residues and re-insert the portafilter into the group.

Press the rotary switch on the group to be rinsed, then select  the screen will show:

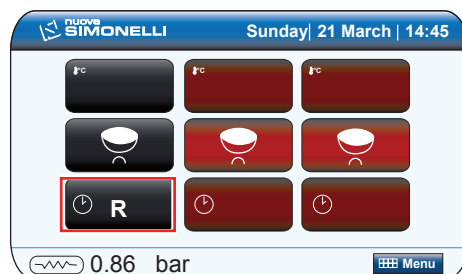

NOTE: During the selected group wash cycle, it is possible to deliver coffee from the groups that have not been selected.

8. CLEANING

8.1 SWITCHING OFF THE MACHINE

Stop the machine with the three main switches, moving them to the position 0.



8.2 CLEANING THE OUTSIDE OF THE MACHINE

The machine must be set to "0" power (switch off and disconnecter open) before any cleaning operations are performed.



WARNING

It is not possible to clean the machine using water jets or standing it in water



WARNING

Do not use solvents, chlorine-based products or abrasives.

Cleaning the work area: remove the worktop, lifting it up from the front and sliding it out. Remove the water collection dish underneath and clean everything with hot water and cleansers.

Cleaning the bottom: To clean all the chromium-plated areas, use a soft, damp cloth.

8.3 CLEANING THE STAINLESS COFFEE-HOLDERS

The stainless steel showers are located under the delivery units.



NOTE: To clean proceed as follows:

- Turn the screw placed in the centre of the coffee-holder.
- Slide the coffee-holder out and check that its holes are not obstructed but clean.
- If obstructed, clean as described (Paragraph "CLEANING FILTERS AND FILTER-HOLDERS")
We recommend cleaning the coffee-holder once a week.

8.4 CLEANING THE UNIT WITH THE AID OF THE BLIND FILTER

The machine is set to wash the delivery group with an automatic cleaning cycle and specific powder detergent.

It is advisable to wash the machine at least once a day.

8.5 CLEANING FILTERS AND FILTER-HOLDERS

Place two spoonfuls of special cleanser in half a litre of hot water and immerse filter and filter-holder (without its handle) in it leaving them to soak for at least half an hour. Then rinse abundantly with running water.

9. MAINTENANCE

NOTE: During maintenance/repairs, the parts used must be able to guarantee compliance with the safety and hygiene requirements envisaged for the device. Original replacement parts can offer this guarantee.

NOTE: After the repair or replacement of any components of parts that come into contact with food or water, it is necessary to carry out the washing procedure as described in point 1.4 or according to the manufacturer's instructions.

9.1 RESIN AND SOFTENER REGENERATION

To avoid scaling deposits in the boiler and in the heating exchangers, the softener must always be kept efficient.

Therefore, the ionic resins must be regularly regenerated.

Regeneration times are established according to the quantity of coffee delivered daily and the hardness of the water utilised

These can be seen in the diagram included in the following figure.

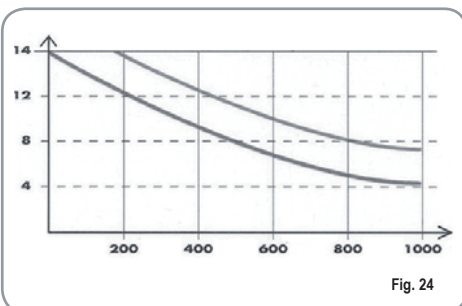

Fig. 24

Regeneration procedures are as follows:

1) Turn the machine off and place a container large enough to contain at least 5 litres under tube E.

Turn levers C and D from left to right; take the cap off by unscrewing knob and fill with 1 Kg normal kitchen salt.

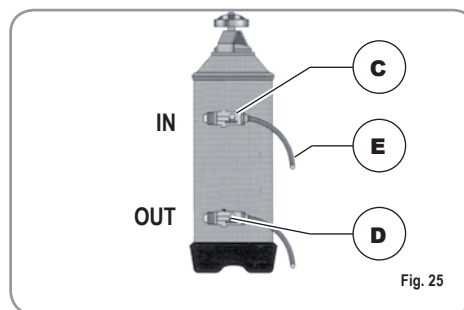

Fig. 25

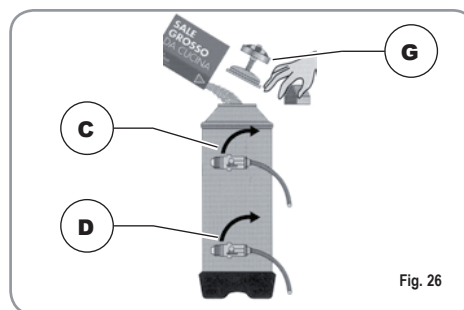

Fig. 26

2) Put the cap back on and reposition lever C moving it towards the left and allowing tube F to discharge the salty water until it has been eliminated and the water becomes fresh again (about half an hour).

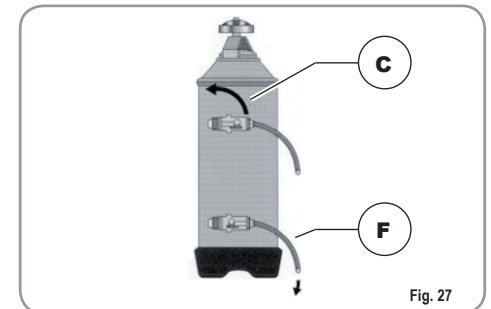

Fig. 27

3) Reposition lever D towards the left.

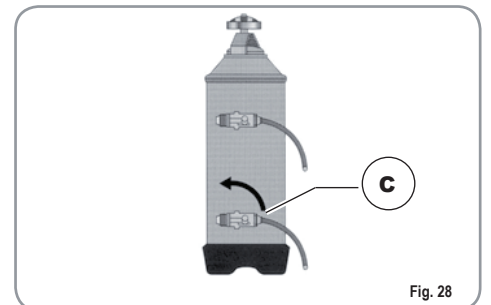

Fig. 28