

DONPER USA—USER MANUAL

# DONPER USA



## Model BH7480 & BT7280 User Manual

[support@donperusa.com](mailto:support@donperusa.com)

[www.donperusa.com](http://www.donperusa.com)    1-844-DONPER1

# DONPER USA

Thank you for your purchase of a Donper Soft Serve Machine.

It is important to read the entire User Manual before operating the machine, as there are several safety issues you must know and understand to safely operate the machine.

If you have any questions about the material in this manual, please call Donper USA at 1-844-366-7371 or email us at [Sales@DonperUSA.com](mailto:Sales@DonperUSA.com). Do not operate the machine until you have read and understood the material in this manual.

Thank you again for your purchase and enjoy your machine!

**[support@donperusa.com](mailto:support@donperusa.com)**

# Table of Contents

Introduction	4
Machine Specifications	5
Machine Parts Identification	9
Installation	10
Operating the Machine	12
Controls	12
Wash Mode	14
Auto Mode	15
Adjusting Product Firmness	15
Standby Mode	16
Cleaning	19
Reassembly After Cleaning	22
Adding Mix to the Machine	24
Error Codes and Solutions	25
Routine Maintenance	30
Troubleshooting	35
Warranty	38

# Introduction

The Donper Model BH7480 soft serve machine, when properly operated and maintained, is designed to produce a smooth and creamy product to be enjoyed by all. However, it is important to understand that the 7480 is a machine, and like ALL machines, the 7480 will require regular cleaning and maintenance to ensure proper and safe operation.

Failure to clean and maintain the 7480 as described in this manual will reduce the performance and operational life of the machine, as well as voiding the machine warranty provided by Donper USA.

The following symbols will be used throughout this manual:



General Information



Cautionary Information



Important Safety Issue - Careful Attention Required to Avoid Injury.



Electrical Shock Hazard - Careful Attention Required to Avoid Injury.

**To avoid physical injury, this User Manual must be read and understood completely before operating or performing any installation or maintenance on the machine.**

**Call 1-844-366-7371 before operating the machine if you have any questions about the instructions in this manual.**



# Machine Specifications

Electrical Requirements (BH7480)	
Voltage	230 V 60 Hz Single Phase
Rated Input Power	22 A (4.6 kW)
Power Plug Type	NEMA L6-30P
Required Breaker Size	30A, Double Pole
Main Compressor	2 HP R404A
Hopper Cooling Compressor	1/6 HP R134A
Drive Motors (ea)	1 HP (750W)

Size and Capacity (BH7480)	
Freezing Cylinders (ea)	2 Qt (1.9 L)
Refrigerated Hoppers (ea)	9.5 Qt (9 L)
Appx. Hourly Production*	46-59 Qt (44-56 L)
Height	56.5 in (1435 mm)
Width	21.25 in (540 mm)
Depth	30.5 in (750 mm)
Weight	397 lbs (180 kg)
R404A (main compressor)	900 g
R134a (hopper compressor)	130g



A dedicated 30 amp circuit is required to operate the machine.

Using a shared circuit may damage the machine and will void the machine warranty.

The machine uses an air cooled refrigeration system which requires a minimum of 6-8 inches of clearance on the left and right sides of the machine and at least 8 inches of clearance behind the machine.

# Machine Specifications

## BH7480

RIGHT SIDE VIEW

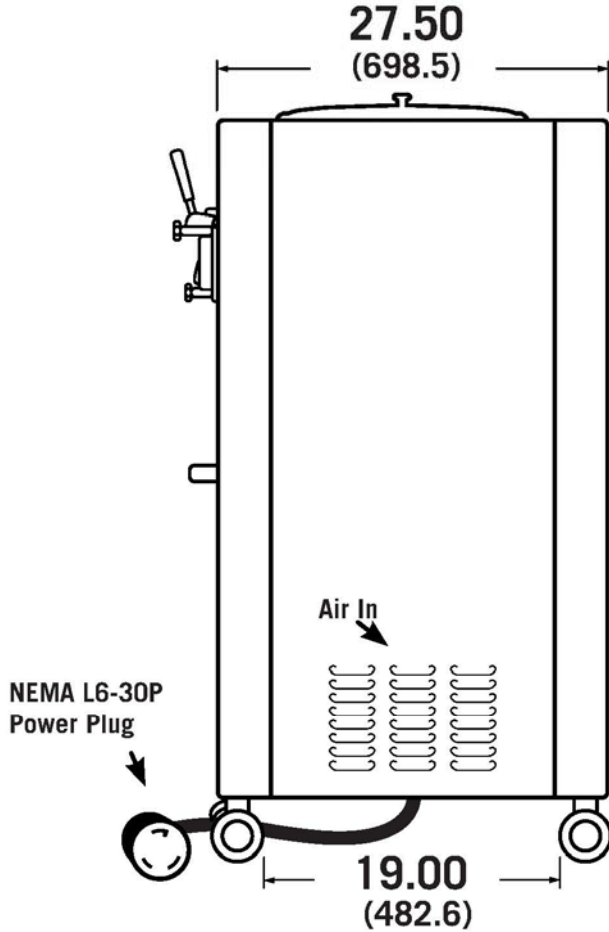

FRONT VIEW

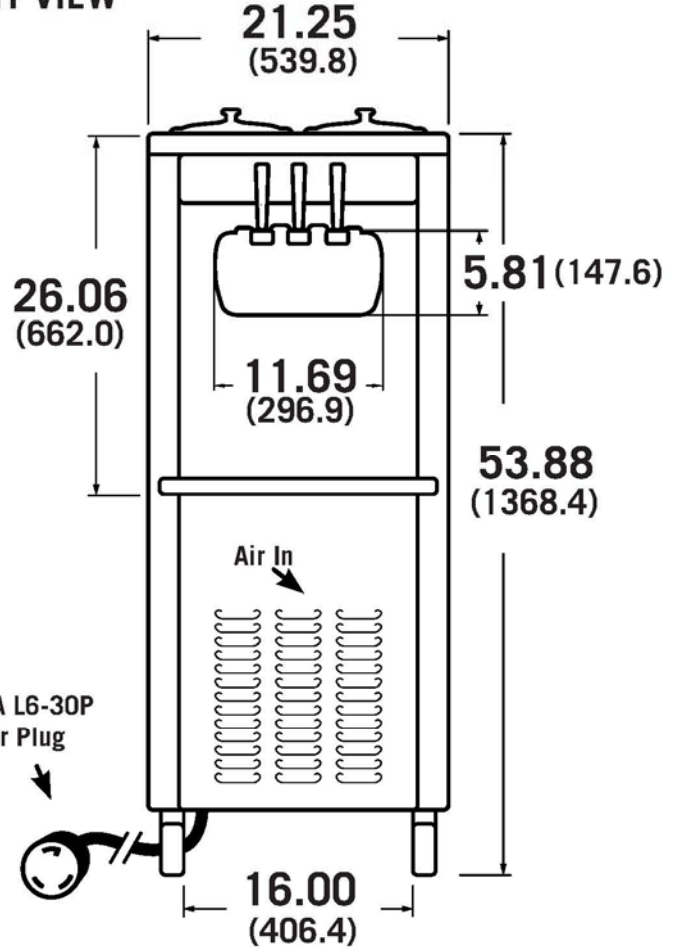

TOP VIEW

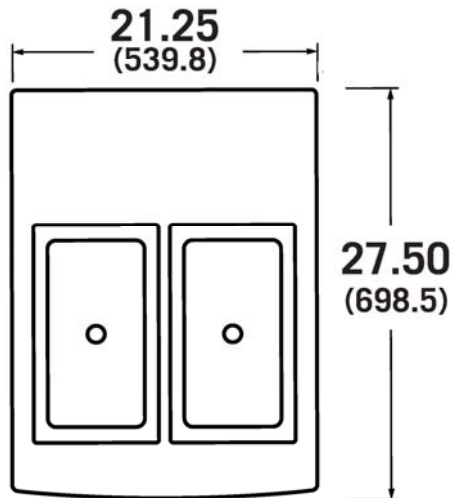

# Machine Specifications

Electrical Requirements (BT7280)	
Voltage	230 V 60 Hz Single Phase
Rated Input Power	22 A (4.6 kW)
Power Plug Type	NEMA L6-30P
Required Breaker Size	30A, Double Pole
Main Compressor	2 HP R404A
Hopper Cooling Compressor	1/6 HP R134A
Drive Motors (ea)	1 HP (750W)

Size and Capacity (BT7280)	
Freezing Cylinders (ea)	2 Qt (1.9 L)
Refrigerated Hoppers (ea)	9.5 Qt (9 L)
Appx. Hourly Production*	46-59 Qt (44-56 L)
Height	32.5 in (1435 mm)
Width	21.25 in (540 mm)
Depth	35.5 in (750 mm)
Weight	352 lbs (180 kg)
R404A (main compressor)	900 g
R134a (hopper compressor)	130g



A dedicated 30 amp circuit is required to operate the machine.

Using a shared circuit may damage the machine and will void the machine warranty.

The machine uses an air cooled refrigeration system which requires a minimum of 6-8 inches of clearance on the left and right sides of the machine and at least 8 inches of clearance behind the machine.

# Machine Specifications

## BT7280

RIGHT SIDE VIEW

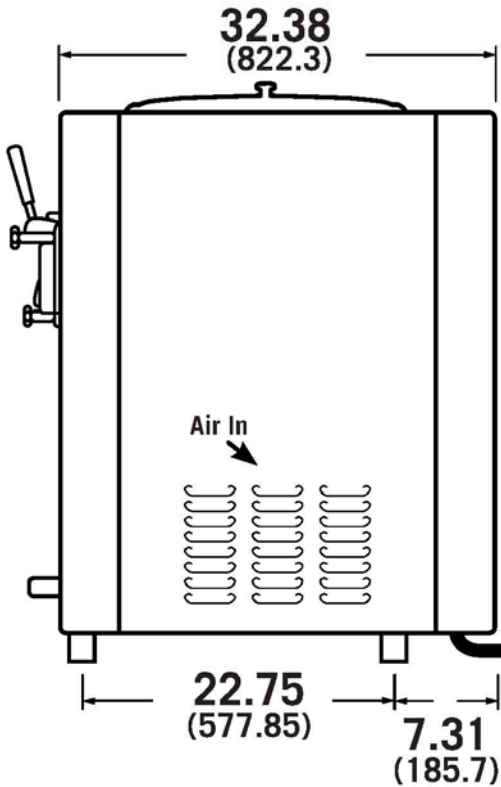

FRONT VIEW

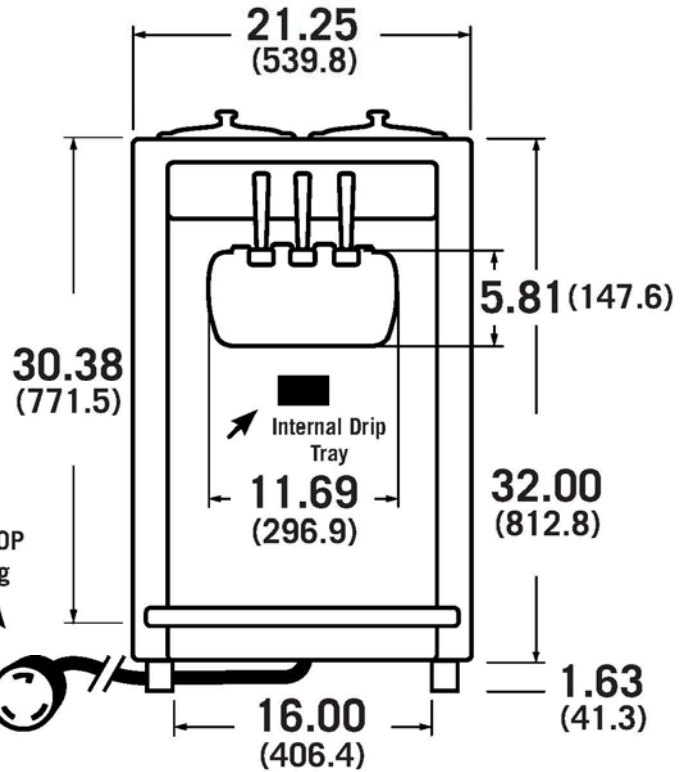

TOP VIEW

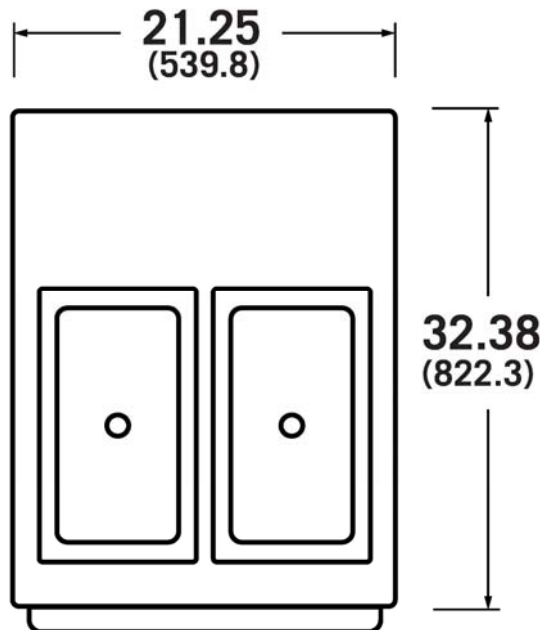

Measurements in Inches  
(millimeters)





**Beater Assembly with Scraper Blades & Shaft Seal**



**Outer Draw Valve with O-Rings**



**Feed Tube with O-Rings**



**Middle Draw Valve with H-Seal**



**Donper Dispenser Head Knob**

**Item #: DNP13583374**



**Donper Door Bearing**

**Item #: DNP68045043**



**Donper Scraper Blade**

**Item #: DNP91592407**



**Donper Shaft Seal**

**Item #: DNP95019531**



**Donper Drip Tray Liner**

**Item #: DNP38058471**



**Donper Drip Tray Splash Shield**

**Item #: DNP84671020**



**Donper Drive Belts**

**Item #: DNP40228271**



**Donper Feed Tube O-Ring**

**Item #: DNP62991333**



**Donper Draw Valve O-Ring**

**Item #: DNP87539672**



**Donper Middle Draw Valve H-Seal**

**Item #: DNP92935180**



**Donper Dispenser Door**

**Item #: DNP24810791**



**Donper Dispenser Door O-Ring**

**Item #: DNP25063449**

# Installation

The BH7480 is shipped on a pallet and the machine is secured/bolted to the pallet to prevent shipping damage. To install the machine, the bolts connecting the pallet bracket to the base of the machine must be removed. Once the pallet bracket bolts are removed, the machine may be carefully removed from the pallet.

**USE EXTREME CAUTION REMOVING THE MACHINE FROM THE PALLET.** Professional unpacking and installation is recommended due to the weight of the machine and potential bodily injury due to improper handling.



**!** Model BH7480 units use air cooled refrigeration systems and require a minimum of 6-8 inches of clearance around the sides of the machine and 8 inches around the back panel to allow for adequate air flow. Failure to allow proper clearance will restrict the airflow into the machine, will reduce the refrigeration capability, and will likely cause overheating and/or damage to the cooling system of the machine.

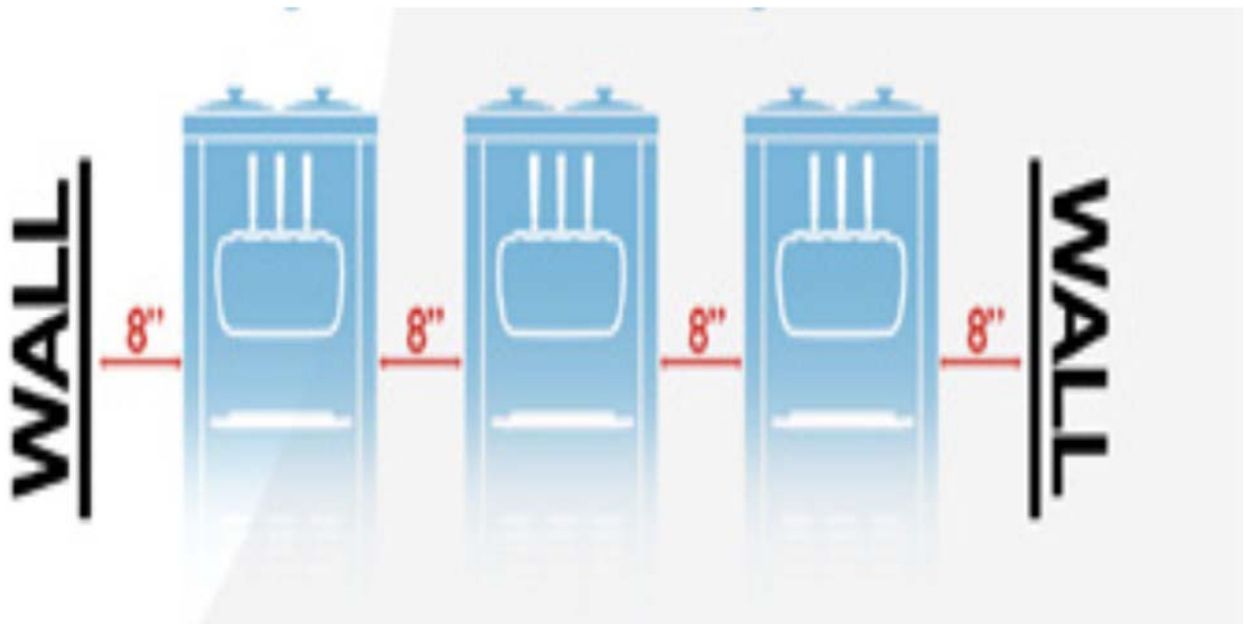



This equipment is intended to be installed in accordance with the National Electrical Code (NEC), NFPA 70. A licensed electrician must install the electrical connections for the machine to insure safe operation. The machine must be properly grounded. Failure to properly ground the machine can result in severe bodily injury from electrical shock.



**ELECTRICIAN** — When making the electrical connections, note that the beater rotation must be counter clockwise as viewed looking into the freezing cylinder from the front of the machine. If the rotation direction is incorrect, it will be necessary to change the position of the hot wires in the machine plug to allow the motors to rotate in the correct direction.

# Operating the Machine

Below are the controls for the machine:

Dispense valve handles. Left and right handles dispense pure product and the middle handle dispenses a mix or twist of the 2 pure products.

Hopper refrigeration power switch. This turns on the secondary compressor that cools the product in the 2 hoppers.

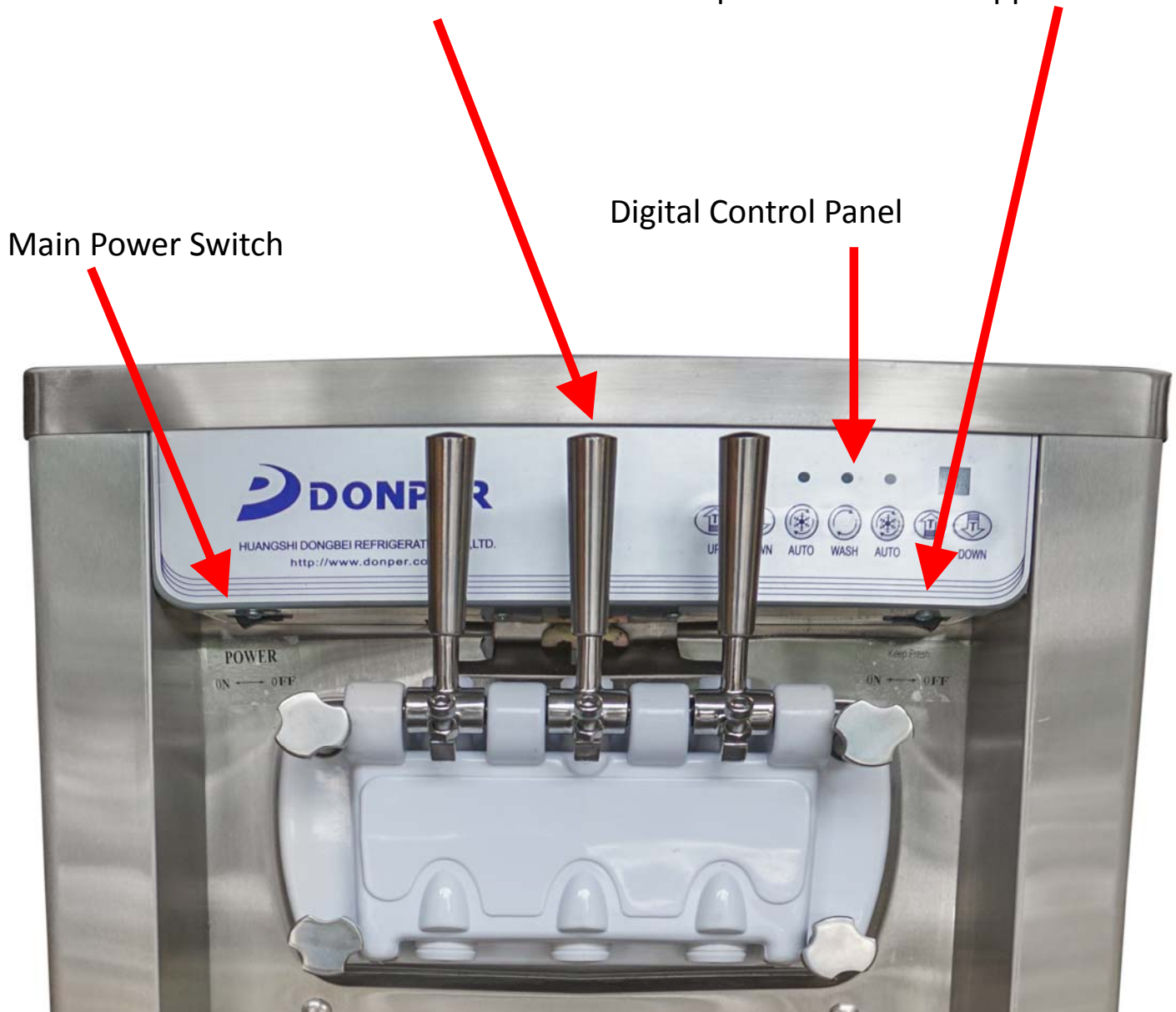

# Operating the Machine

Machine Controls (cont') for BH7480 and BT7280

- 1) Dispensing Handles
- 2) Main Power Switch
- 3) Valve Body Thumb Screws
- 4) Drip Tray Cover
- 5) Hopper Cooling Switch
- 6) Valve Body
- 7) Drip Tray

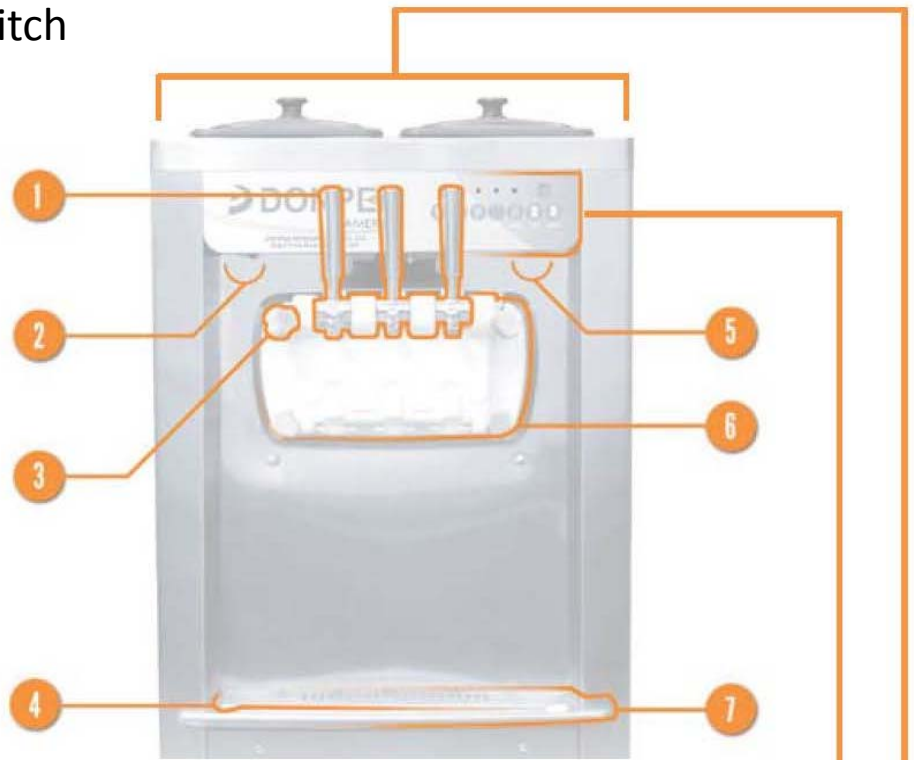

- A) Level Switch
- B) Air Cap
- C) Feed Tube



Front Control Panel



Refrigerated Hoppers with Feed Tubes Installed

# Operating the Machine (cont')

To operate the machine in any mode, the main power switch must first be turned to the “ON” position.

The machine has 3 operating modes:

- 1) Wash Mode: This is when the refrigeration system is turned off and the mixing motors are running. You use this mode to circulate cleaning or sanitizing solution through the machine hopper and barrels.
- 2) Auto Mode: This is the normal operating mode of the machine where the refrigeration system and the mixing motors are on so that the machine is freezing and preparing soft serve product to serve.
- 3) Standby Mode: This is where the machine is configured to keep the product in the barrels refrigerated for extended periods of time (during slow sales periods or even overnight).

## OPERATING IN THE WASH MODE:

Press the “Wash” button and the “Wash ” indicator light will turn on. Both the right and left mixing motors will turn on simultaneously. To stop, simply press the “Wash” button again. During the Wash Mode, the refrigeration system for the freezing cylinders will be OFF. Wash Mode only rotates both beaters inside of the freezing cylinders without any freezing. Wash Mode is used to drain mix from the machine or rinse the beater assemblies with water or sanitizing solution.

# Operating the Machine (cont)

## OPERATING IN THE AUTO MODE:

There are two Auto buttons on the front control panel, one for the left barrel and one for the right cylinder. The two sides can be controlled independently of each other. Press the Auto button on the control panel to begin freezing inside the corresponding freezing cylinder. When in Auto Mode, the indicator light will turn on along with the corresponding beater motor. The numeral values on the display will increase from 0 to 99 and then stop at 00. When the number value reaches 00, this indicates that the product in the freezing cylinder is ready to serve. When the number reaches 00, the indicator light above the AUTO button will then flash, indicating that the product is ready and has reached the desired firmness level. Note that the hopper cooling switch should also be turned on during the AUTO mode operation to keep the product in the hoppers refrigerated and to prevent spoiling. **NEVER RUN THE MACHINE IN AUTO MODE WITH WATER IN THE FREEZING CYLINDERS—DAMAGE WILL OCCUR.**



### Adjusting the Product Firmness Level:

With the Power Switch ON and both Auto buttons OFF, press the up and down buttons simultaneously and hold for 5 seconds (machine will beep 5 times) for the side you wish to adjust. A numerical value of 1 to 10 (the firmness setting) will begin to flash on the screen. Use the up and down buttons to adjust the firmness setting with 1 being softer product and 10 being firmer product. Once the firmness is set, the control panel will automatically return back to “00” after about 10 seconds of no further adjustments.

# Operating the Machine (cont)

## Adjusting the Product Firmness Level: (cont')

The recommended starting setting for the product firmness level is 5. With your product in the machine for the first time and the AUTO feature running, wait until the display cycles from 0 to 99 and then shows 00. Dispense some of the product from the machine and check the consistency/firmness. If a firmer product is desired, then increase the firmness setting by 1-2 and allow the machine to recycle back to 00 again and retest the firmness. Repeat this process until the desired product firmness is reached.

As a guide to help determine the appropriate product firmness setting, the numbers on the display in AUTO mode should start at 0 and quickly rise to about 84 to 87 when the product inside the freezing cylinders is in a complete liquid state (for example, when the machine is first filled with fresh product and started after cleaning). If the numbers rise above 87 to start, then increase the firmness setting 1-2 number values and restart the AUTO mode and observe if the numbers stop increasing rapidly somewhere near 84-87.

## OPERATING IN THE STANDBY MODE:

During long non-use periods, the machine can be placed in Standby Mode in order to keep the product inside the freezing cylinders refrigerated.



# Operating the Machine (cont)

## OPERATING IN THE STANDBY MODE: (cont')

To start the Standby mode, with the machine in Auto Mode on both sides, press and hold the Wash button for five (5) seconds (machine will beep 5 times), then release. The LCD displays will now alternate between “00” and “bb”. Both mixer motors will turn off and the refrigeration system will keep the product in the cylinders refrigerated. In this mode it is also necessary to make sure that the hopper cooling system switch is set to ON. Not turning the hopper cooling switch on will allow the product in the hoppers to spoil.

Normal Feed Tube  
Position

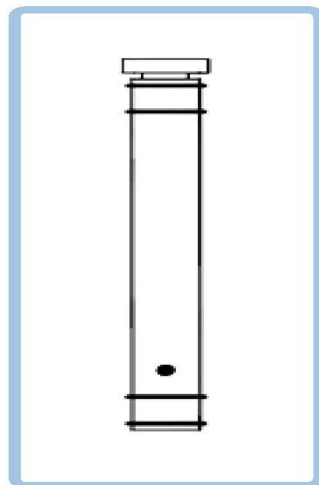

Standby Feed Tube  
Position

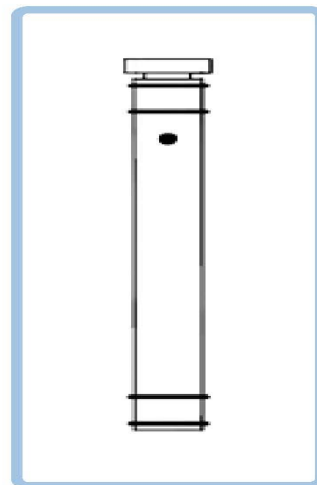

To enter standby mode you must also remove the feed tubes from inside the hoppers and reverse their position, as shown above. To do this you first remove the air caps from the top end of the feed

## Operating the Machine (cont)

### OPERATING IN THE STANDBY MODE: (cont')

tube and insert into the bottom end. Now, insert the feed tubes back inside (reverse insertion positioning) the hopper to prevent product from entering the freezing cylinder. The hole-side of the feed tube should now be at the top.

When in the Standby Mode is it also advised to remove the valve caps (typically the star shaped caps) from the dispensing aperture of the valve body. You should also remove the drip tray and drip tray cover. These parts should be sanitized upon removal and dried for later use. The exterior of the machine, and specifically the valve body, should also be cleaned and sanitized.

To exit Standby Mode and return to normal operation (Auto Mode), press and hold the Wash button for five (5) seconds (machine will beep 5 times), then release the Wash button. The machine will return to the Auto Mode when the Wash button is released and will begin rotating the augers and cycling the refrigeration system so that the product is frozen to the selected consistency.

When exiting the Standby Mode and returning to the Auto mode, the feed tubes must be reversed from the Standby position with the holes positioned on the top of the feed tube to the normal operating position with the holes being nearer the bottom so that the product mix can flow into the freezing cylinder. Failure return the feed tubes to the Auto position may result in damage to the machine.

# Cleaning the Machine

## Draining Product from the Machine

Step 1: Turn the Auto Mode OFF for both freezing cylinders. Place the hopper cooling switch in the OFF position.

Step 2: Remove the hopper lids and feed tubes from the hopper. Remove the all of the star caps from the dispenser valves.

Step 3: Unscrew the Adjustable Flow Rate Screws in the handles to allow the draw valves to fully open.

Step 4: Place a large bucket beneath the dispenser door. Press the Wash button. Pull and hold all three (3) handles down until all the product is removed from the freezing cylinders and hoppers. Press the Wash button to turn Wash Mode off.

Step 5: Pour water/cleaning solution into the hoppers and repeat step 4 until the water being drained into the bucket comes out clean.

## Cleaning the Machine (Quick Rinse & Sanitize)

Every 2-3 days the machine should be shut down and fully cleaned. For mix changes or sanitizations between product changes, follow the steps below.

Step 1: Pour a gallon of room-temperature water into each hopper. Allow the water to flow down into the freezing cylinders. Using a tube brush, clean the inside of the hoppers including the L-shaped level probes.

Step 2: Press the Wash button and run in Wash Mode for 1-2 minutes.

# Cleaning the Machine

## Cleaning the Machine (Quick Rinse & Sanitize cont')

Step 3: While the unit is in Wash Mode, place a large bucket beneath the dispenser door. Pull and hold all three (3) handles down until all the water is removed from the machine. Press the Wash button to turn Wash Mode off and discard the water.

Step 4: Repeat this rinse process 2-3 more times until the discarded water becomes clear.

Step 5: Repeat steps 1-3 using water containing approved sanitizing solution and then rinse with a water solution.

Step 6: If the machine is to be immediately run with new product, then pour 1-2 cups of the product into the hoppers, activate the WASH mode, and dispense the product out the valves until the water remaining in the cylinders is pushed out by the product.

If the machine is not going to be run immediately with new product after cleaning, you will need to remove the dispensing door and beater bars and dry the freezing cylinder and beater bar components to prevent corrosion or oxidation (rust). Once you've removed the dispensing door and beater bars it's a good practice to go ahead and do the full clean process of the components in a sink with warm soapy water before reassembling the machine parts (after clean rinsing and drying all parts).

.

# Cleaning the Machine

## Complete Cleaning of the Machine

Step 1: Conduct the quick cleaning and sanitization steps noted above.

Step 2: Remove the valve body components by first removing the valve body retaining pin, as shown below.



Step 3: With the handle pin removed, remove the valve assemblies (handles and plungers) from the valve body. ◀

Step 4: Unscrew the 4 thumb screws and remove the valve body from the machine.



Step 5: Remove the beater bar from the freezing cylinder. Use caution when removing the beater bar, as the scraper blade edges are sharp and may cause injury.

Step 6: Prepare a sink of the sanitizer solution and warm water. Use a brush kit to thoroughly clean each of the disassembled parts. Use a small pipe brush to clean the channels in the valve body that the soft serve flows through. Remove the scraper blades and seal from the beater bar and clean all components thoroughly.

Step 7: Clean the freezing cylinder and hopper with sanitizing solution using a large tube brush.

Step 8: Dry all of the cleaned components in preparation for re-assembly. Dry the inside of the freezing cylinder and the hopper.

# Reassembly after Cleaning

**Step 1:** Make sure the Power switch is in the OFF position. Lubricate the inside surface of the shaft seal and slide the shaft seal down onto the end of the beater bar shaft so that the flared-end of the shaft seal points away from the beater bar. Then place a small amount of additional lubricant on the inside of the flared-end of the shaft seal.

**Step 2:** Re-attach the four (4) scraper blades back onto both beaters. Be sure the scraper blades slide completely under the stainless steel tabs at the end of each blade.

**Step 3:** Slide the beater assemblies inside the freezing cylinder, shaft side first. Be sure the shaft end engages into the back of the freezing cylinder. To engage the shaft, lightly push the beater bar toward the back of the machine and slowly rotate the beater bar until the square end of the shaft fits into the corresponding socket in the back of the freezing cylinder.

**Step 4:** Reattach the door bearings and screw on the rods onto the back side of the dispenser door. Use the handle pin to gently tighten.

**Step 5:** Place the dispenser door o-rings into the grooves and lubricate the O-rings, as the lubrication helps the O-rings to stick to the dispenser door while it is being mounted on the machine.

**Step 6:** Slide the door flush onto the freezing cylinder, checking to confirm that the O-rings stayed in the grooves. Tighten the door knobs equally in a criss-cross pattern to ensure the door is snug. The longer knobs should be screwed into the top two sockets and the shorter knobs should be screwed into the bottom two positions. Be sure dispenser door o-rings are securely in place before moving forward. Do not overtighten the knobs, as this will cause the seals to fail and the machine to leak.

**Step 7:** Lubricate the o-rings on the three (3) draw valves. Slide the draw valves into the dispenser door from the bottom until the slot in the draw valves comes into view through the hole where the handle is inserted. Be sure the draw valve slot is facing forward. Wipe away excess lubricant.

# Reassembly after Cleaning

Step 8: Snap the star caps onto the dispenser door spouts. Install the three (3) handles and slide the handle pin into place.

Step 9: Install the air cap onto the feed tubes. Make sure the hole in the air orifice is not clogged. If clogged, use soap, water, and a brush to clear the hole. Do not enlarge the hole in the cap.

See step 4 above for this picture.

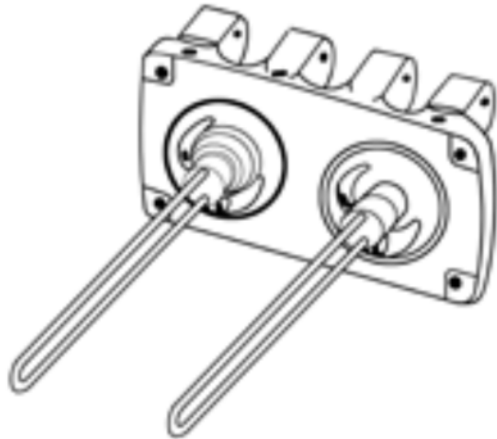

See step 9 above for this picture.



# Adding Mix Into the Machine

Step 1: With the feed tubes removed from the hoppers, pour a small amount of mix (appx 2 cups) into one of the hoppers. As product starts to fill the freezing cylinder, push down on the hopper's corresponding handle. The remaining sanitizer within the freezing cylinder should begin to flow out ahead of the mix. As soon as only mix is being dispensed, return the handle to the closed position. This step ensures that all excess sanitizer has been removed from the freezing cylinders.

Step 2: Pour the rest of the mix into the desired hoppers.

Step 3: Once the bubbles stop rising from the hole openings in the hoppers, insert the feed tubes with the hole closest to the bottom and insert the air caps as needed. Place the cover on the hoppers and turn on the Hopper Cooling Power Switch.

Step 5: Press the Auto button to begin freezing. The Auto indicator light will turn on and the mix will be frozen and ready to dispense in about 7-10 minutes under normal conditions.

When the Auto mode is selected, the numbers on the control panel should begin at 0 and quickly rise to about 84 to about 87 when the machine first begins freezing the mix from a liquid state. If the numbers slow down in their rise before reaching 84 or pass by 87 without slowing down, then adjust the consistency or firmness setting and restart the Auto mode.

If the Auto mode number goes past 87 quickly, then decrease the firmness setting number and restart the Auto mode.

If the Auto mode number slows before reaching 84, then increase the firmness setting number and restart the Auto mode.



# Error Codes

The following error codes may be displayed on the control panel. Follow the troubleshooting recommendations below and contact your service provider if the problem continues.



## Problem

1. Beater motor rotational speed is low according to the sensor.
2. Belt is slipping on the pulley.

## Solution

1. Visually inspect the drive belts by removing the rear panel of the machine. Be sure the machine is powered OFF and unplugged before inspecting. Look for signs of cracking, tears, uneven wear, or excessive belt looseness. If signs do exist, replace drive belts with new ones.
2. If the belts are in good condition, check the tightness of the belts. The belts should not move more than about 1-2 inches horizontally when tightened properly. If they move more than 1-2 inches, tighten the belts and reassemble the machine to test the results.

If problems persist, contact an authorized repair technician.



Unit is in the standby mode. To exit the standby mode, press and hold the Wash button for 5 seconds.

# Error Codes



## Problem

1. The temperature inside the freezing cylinder has dropped below 10°F (-12°C) when the machine is in Standby mode.
2. Temperature sensor(s) are disconnected from the main circuit board or are not operating properly.

## Solution

1. Check the freezing cylinder to make sure product has not frozen solid. If the product is frozen solid, turn machine off for 45 minutes and allow time to defrost before restarting. Adjust the Product Firmness Level as needed to a lower number (from 7 to 4 for example). If problems persists, contact an authorized service technician.



## Problem

1. The temperature inside the freezing cylinder has risen above 140°F (60°C) or the temperature sensor circuit is short.

## Solution

1. Inspect R404A refrigeration system to be sure high side and low side pressures are correct. If problems persist, contact an authorized service technician.



## Problem

1. Product level in hopper is low. Unit will beep three (3) times while “CL” flashes in the display.

## Solution

1. Refill hopper with more product. After the hopper has been re-filled, the display will no longer flash. If problems persist, contact an authorized service technician.

# Error Codes



## Problem

1. Machine has entered Low Temperature Protection. When the temperature of the freezing cylinders has dropped below 10°F (-12° C) while the machine is in Auto Mode, the compressor will turn off and go into Discharge Mode.

## Solution

1. In Auto Mode, the machine automatically detects the temperature of the product in the freezing cylinder via temperature probes. This Low Temperature Protection is to prevent the product from over freezing and possibly freezing solid. If over freezing occurs, turn the machine off for 10 minutes and then decrease the firmness setting to a lower number (change from 7 to 4, for example) and restart the machine. If problems persist, contact an authorized service technician.



## Problem

1. Breaker in the side panel access door is tripped.
2. Frozen product in the freezing cylinder or object restricting the rotation of the beaters or problem with beater motor. Check for loose wiring, overheating, or faulty starting components.
3. Faulty rotational movement sensor(s).
4. Rotation sensor(s) disconnected at the main circuit board.

## Solution

1. Switch breaker(s) to the upright position.
2. Set Auto Mode OFF and decrease the temperature setting to soften product (See Section 5). Be sure product is not completely frozen solid inside the freezing cylinder before restarting.

# Error Codes



## Cont'

3. With the unit powered OFF and UNPLUGGED, carefully inspect beater motors with rear panel removed. Check for overheating, loose wiring, or any signs of obstruction. If motors seems excessively hot, allow time for the machine to cool down before restarting. If problems persist, call an authorized service technician.

4. Inspect the rotational sensors.

5. Inspect the main circuit board for proper connection.



## Problem

1. Dispensing handle has been left open for over 60 seconds.

2. Dry torsion spring assembly.

## Solution

1. Return handle(s) back to upright position. Turn power switch OFF and restart as normal. Draw valves may not easily return to their original position if the proper amount of lubricant was not applied to the draw valve o-rings or h-rings. Make sure that there is enough lubricant on each draw valve when assembling the machine.

2. Lubricate torsion spring assembly.

If problem still exists, inspect limit switch located behind the control panel for any malfunction, and contact an authorized service technician.

# Error Codes



## Problem

1. High pressure switch has been activated.

## Solution

1. If the high pressure switch is activated, the unit will beep and display “HH” on the LCD screen. This is caused by high pressure being detected at high pressure side of the main compressor refrigeration system.

## Possible causes:

High ambient temperature

Poor cooling from the condenser

Poor air circulation around the machine

Faulty main condenser fan

Dirty condenser coils



**Contact an authorized commercial refrigeration technician to inspect the refrigeration system.**

# Routine Maintenance

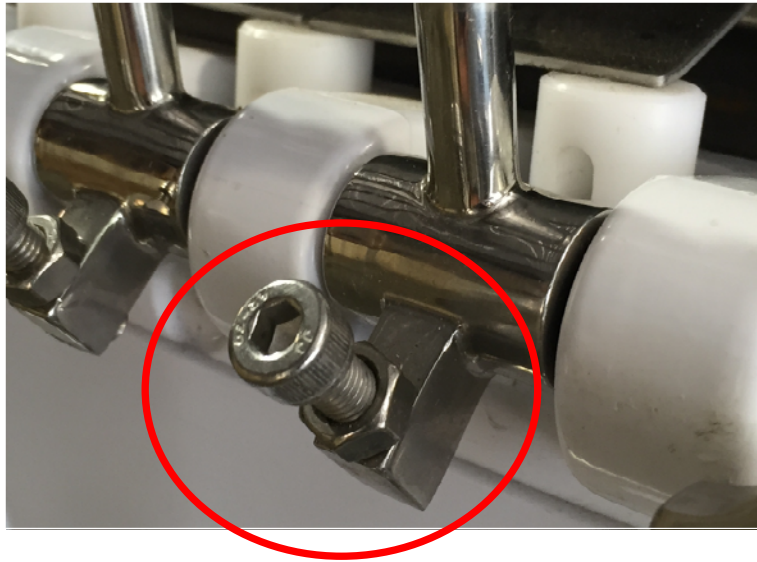

The dispensing handles feature adjustable flow rate screws to control how fast the product is dispensed. To increase the flow rate, turn the screw counterclockwise (loosen). To decrease the flow rate, turn the screw clockwise (tighten). Once you have the flow rate screw in the desired position, tighten the nut on the threaded screw against the handle. This will prevent the flow rate screw from moving/turning away from your desired set point for the flow rate. During sanitizing and rinsing, the flow rate screws should be unscrewed to a “wide open” position to allow the water and sanitizer to freely flow through the orifices.

# Routine Maintenance

Item Description	Every 4 weeks	Every 3 months	Annually
Replace Shaft Seal		X	
Replace Scraper Blades	X		
Replace Dispenser Door O-rings		X	
Replace Draw Valve O-rings		X	
Replace Feed Tube O-rings		X	
Replace Door Bearings		X	
Replace Drive Belts			X
Clean Condenser			X

- Be sure to drain the product and thoroughly clean and sanitize your unit every 2 to 3 days (or as instructed by health codes within your state). Proper cleaning and preventative maintenance results in a creamier product consistency, increased unit reliability and efficiency, and prevention of costly repairs from occurring in the future. Do not run the machine while the machine is empty. This can severely damage internal parts.
- Be familiar with all the operational modes of your machine and what they do. Understand the different features of each mode for safe and reliable operation.
- Use a recommended soft serve machine cleaner and sanitizer when cleaning your unit. Regular dish soap, chemicals, and detergents can degrade seals and leave unwanted residues in your machine.

# Routine Maintenance

## Things to make sure you DO with your machine.

**ALWAYS** unplug the machine before conducting any maintenance, disassembly, or service. **NEVER** remove any side or back panel of the machine without first unplugging the machine. Serious bodily injury can occur.

Be sure to drain the product, and thoroughly clean and sanitize your unit every 2 to 3 days. Proper cleaning and preventative maintenance results in a creamier product consistency, increases your unit reliability and efficiency, and prevents costly repairs from occurring in the future.

Be familiar with all the operational modes of your machine and what they do. Understand the different features of each mode for safe and reliable operation.

Use a recommended soft serve machine cleaner and sanitizer when cleaning your unit. Regular dish soap, chemicals, and detergents can degrade seals and leave unwanted residues in your machine.

Visually inspect the wearable parts regularly (drive belts, o-rings, shaft seals, dispensing head o-rings, door bearings). Seals, o-rings, and/or belts that are torn, cracking, hardened, or unevenly worn need to be replaced.

Lubricate seals and o-rings with a food grade lubricant.



# Routine Maintenance

## Things to make sure you DON'T DO with your machine.

Do not run the machine while the machine is empty. This can severely damage internal parts.

Do not pour water, product, or any fluid into the hopper while the beaters are removed from the freezing cylinder. Doing this will cause the fluid to be discharged from the machine.

Do not add any candies, jellies, or other particles into the hopper. Particles may clog the passageway leading into the freezing cylinder causing damage to the unit.

Do not operate the machine while the side panels are removed from the unit. Loose garments and long hair can get caught in the moving parts, resulting in serious injury. **ALWAYS unplug the machine before removing any side or rear panel.**

Do not run the machine with water in Auto Mode. The water will solidify into ice, expand, and severely damage the machine internally which might be beyond repair.

## Routine Maintenance (cont')

- Visually inspect the wearable parts regularly (drive belts, o-rings, shaft seals, dispensing head o-rings, door bearings). Seals, o-rings, and/or belts that are torn, cracking, hardened, or unevenly worn need to be replaced.
- Do not run the machine with water in Auto Mode. The water will freeze into ice, expand, and severely damage the beaters, freezing cylinder, bearings, belts, and drive motors which can lead to irreparable damage.
- Lubricate all seals and o-rings with a food grade lubricant. Do not pour water, product, or any fluid into the hopper while the beaters are removed from the freezing cylinder. Doing this will cause the fluid to be discharged from the discharge tube located under the machine.
- Do not add any candies, jellies, or other particles into the hopper. Particles may clog the passageway leading into the freezing cylinder causing damage to the unit.
- Do not operate the machine with any of the side panels removed from the unit. Loose garments and long hair can get caught in the moving parts resulting in serious injury

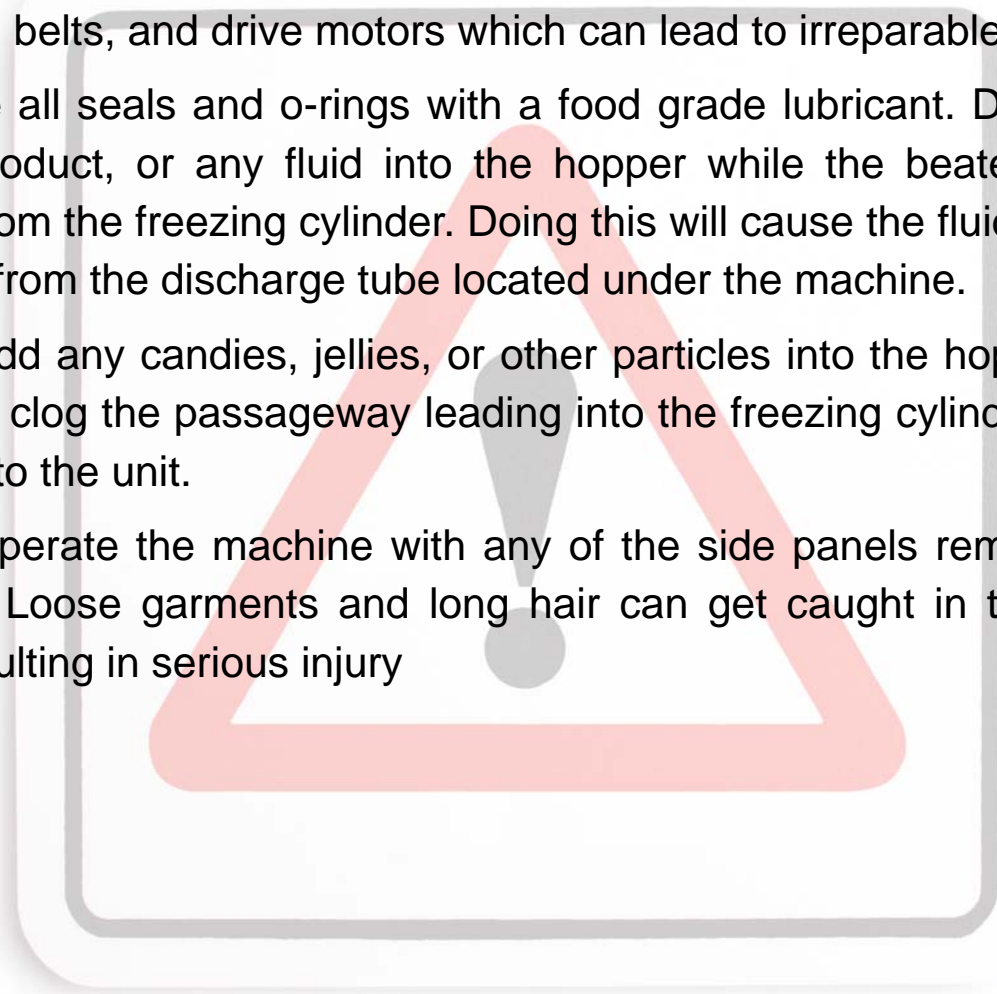

# Troubleshooting

Problem	Possible Cause	Solution
Squealing sound when the handle is pulled down to dispense or when the drive motors turn on during the Auto mode.	<ol style="list-style-type: none"> <li>1. Product inside the freezing cylinder is frozen solid or nearly solid.</li> <li>2. Product Firmness Level is set too high.</li> <li>3. Drive motor belt is loose and needs adjustment.</li> <li>4. Worn or slippery belts.</li> </ol>	<ol style="list-style-type: none"> <li>1. Turn the machine off to allow the mix inside the freezing cylinder to thaw.</li> <li>2. Decrease the Firmness Level Setting (lower number).</li> <li>3. <a href="#">With the machine unplugged</a>, inspect belts for proper tension and tighten as needed.</li> <li>4. With the machine unplugged, replace worn belts with new.</li> </ol>
No product comes out when the draw valve is opened and the machine is in Auto Mode.	<ol style="list-style-type: none"> <li>1. The feed tube is installed with the hole on the upward side instead of the downward side.</li> <li>2. Low level of mix in the hopper.</li> <li>3. Mix inside the freezing cylinder is frozen solid or nearly solid</li> <li>4. Beater is rotating in the wrong direction.</li> </ol>	<ol style="list-style-type: none"> <li>1. Remove and reverse the position of the feed tube so the hole is near the bottom of the tube when installed. .</li> <li>2. Add mix to the hopper.</li> <li>3. Decrease the firmness level (lower number) setting.</li> <li>4. Call the Donper USA service line to correct the motor rotational direction, as an electrician will be needed to evaluate the electrical connections.</li> </ol>
Mix is too firm.	<ol style="list-style-type: none"> <li>1. Mix in the freezing cylinder is too cold.</li> <li>2. The feed tube and/or air cap are not installed correctly.</li> </ol>	<ol style="list-style-type: none"> <li>1. Decrease the firmness level setting (lower number).</li> <li>2. Install feed tube in the standard insertion position (i.e. hole side down).</li> </ol>

# Troubleshooting

<p>Mix is too soft.</p>	<ol style="list-style-type: none"> <li>1. Mix in the freezing cylinder is too warm.</li> <li>2. The mix is aged or over- agitated.</li> <li>3. Not enough space around the machine or obstructions around the machine that prevent proper air flow for the refrigeration system to cool properly.</li> <li>4. Worn scraper blades.</li> </ol>	<ol style="list-style-type: none"> <li>1. Increase the firmness level setting (higher number).</li> <li>2. Replace old mix with fresh product.</li> <li>3. Space machines properly to allow for adequate air flow across the condenser (8” in between machines and 12” behind each machine is optimal).</li> <li>4. Check scraper blades for signs of wear. Replace if there is any damage or if they are unevenly worn.</li> <li>5. Clean the condenser to allow better air flow. <b>Make sure that the machine unplugged before removing the back panel to clean the condenser.</b></li> </ol>
<p>The mix in the hopper is too cold.</p>	<ol style="list-style-type: none"> <li>1. The temperature setting on the thermostat needs adjustment.</li> <li>2. Faulty thermostat.</li> </ol>	<ol style="list-style-type: none"> <li>1. Adjust hopper thermostat temperature.</li> <li>2. Call the Donper USA service line to have thermostat inspected/ replaced.</li> </ol>
<p>The mix in the hopper is warm.</p>	<ol style="list-style-type: none"> <li>1. The temperature setting on the thermostat needs adjustment.</li> <li>2. Faulty thermostat.</li> <li>3. Dirty condenser.</li> </ol>	<ol style="list-style-type: none"> <li>1. Adjust hopper thermostat temperature.</li> <li>2. Call the Donper USA service line to have thermostat inspected and/or replaced.</li> <li>3. Clean the condenser. Make sure that the machine is completely turned OFF.</li> </ol>

# Troubleshooting

<p>The freezing cylinder walls are scored.</p>	<ol style="list-style-type: none"> <li>1. The front dispenser door bearing is missing or worn.</li> <li>2. Improper scraper blade installation.</li> <li>3. Damaged dispenser door.</li> </ol>	<ol style="list-style-type: none"> <li>1. <b>With the machine unplugged</b>, install or replace a new door bearing.</li> <li>2. With the machine unplugged, check scraper blades to make sure they are properly installed (i.e. Check that the blades fit snug onto the beater, and that they are also slid completely under the stainless steel tabs).</li> <li>3. <b>With the machine unplugged</b>, replace with new dispenser door.</li> </ol>
<p>Excessive mix/ water leakage from discharge tube.</p>	<ol style="list-style-type: none"> <li>1. Missing or worn shaft seal.</li> <li>2. Lack of lubrication on the shaft seal.</li> </ol>	<ol style="list-style-type: none"> <li>1. <b>With the machine unplugged</b>, install or replace a new shaft seal.</li> <li>2. <b>With the machine unplugged</b>, lubricate the shaft seal with foodgrade lubricant.</li> </ol>
<p>Excessive mix leakage from dispenser door spout.</p>	<ol style="list-style-type: none"> <li>1. Missing or worn draw valve o-rings.</li> <li>2. Lack of lubrication on the draw valve o-rings.</li> </ol>	<ol style="list-style-type: none"> <li>1. <b>With the machine unplugged</b>, install or replace with new o-rings.</li> <li>2. <b>With the machine unplugged</b>, lubricate the o-rings with a foodgrade lubricant.</li> </ol>
<p>Product is not feeding into the freezing cylinder.</p>	<ol style="list-style-type: none"> <li>1. Not enough mix in the hopper.</li> <li>2. The mix inlet hole on the feed tube is clogged.</li> <li>3. The feed tube is installed upside down.</li> <li>4. The air orifice (feed tube cap) is not installed.</li> </ol>	<ol style="list-style-type: none"> <li>1. Fill the hopper with more mix.</li> <li>2. Remove the feed tube and clear the inlet hole.</li> <li>3. Install the feed tube with the inlet hole side down.</li> <li>4. Install the air orifice (feed tube cap) on the feed tube.</li> </ol>

# Warranty Information

Donper USA is committed to providing quality products and excellent after the sale service and warranty support. As such, every Donper USA soft serve machine comes with a full 2 year non-consumable parts warranty for any manufacturer's defects. We also offer a 3 year warranty on the compressors in the machine. These warranties do not cover abuse, failure to maintain, or failure to conduct preventative maintenance on the machine as noted in this manual.

These warranties are not provided by the manufacturer, these warranties are provided by our company, Donper USA in Houston, Texas. We stock all warranty parts for the Donper machines and our technical support team are available M-F 9am to 4pm CST at 1-844-366-7371 to assist with any technical service issues and to dispatch warranty parts via overnight delivery. We'll do our best to help you resolve any issues as quickly as possible to minimize your down time.

Donper USA soft serve machines have an optional 1 year labor warranty that is available. Please inquire to your sales representative if you are interested in purchasing the labor warranty at the time of your purchase.

Thank you for your purchase and we hope you'll enjoy several years of reliable operation from your Donper USA machine.