



CE ISO 9001

## D600 SOFT SERVE MACHINE

The D600 is the perfect entry level soft serve machine for any location. With low power consumption, strong production, two flavors and a twist, hopper cooling, and digital consistency controls, the D600 has all the features of much more expensive machines. The D600 is an air cooled countertop model that requires only a power plug to start producing smooth creamy soft serve at your location.

### Features

- Air cooled countertop model
- Two flavor with twist
- Serves frozen yogurt, sorbet, soft serve ice cream, etc
- 15-20 min approximate freeze time to first dispense frozen product
- Refrigerated hoppers for faster recovery times
- Product consistency is adjustable by an LCD control

**DONPER** USA

Donper USA  
500 Stonegate Dr.  
Katy, TX 77494

1-844-366-7371  
sales@donperusa.com  
www.donperusa.com

# D600

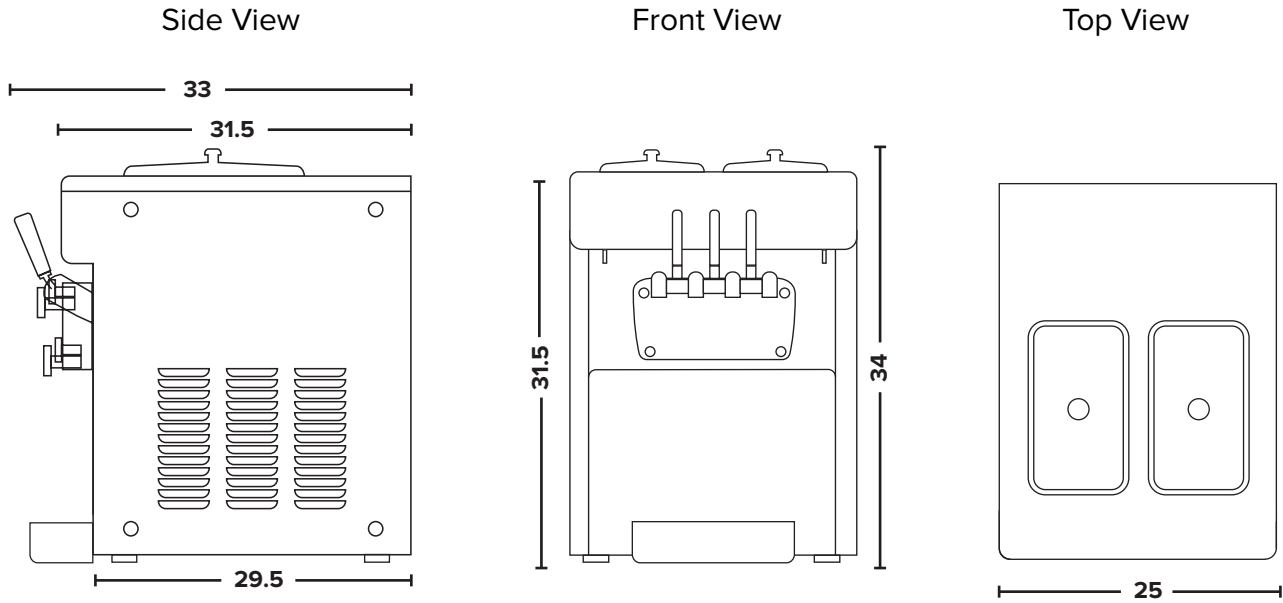

Measurements in inches.

## Size and Capacity

Freezing Cylinders (each)	1.7 Qt (1.6 L)
Refrigerated Hoppers (each)	5.8 Qt (5.5 L)
Height	34 in (864 mm)
Width	25 in (635 mm)
Depth	33 in (838 mm)
Weight	230 lbs (105 kg)

## Electrical

Voltage	115 v
Phase	Single
Rated Input Power	20A (2300 W)
Breaker Size	20A
Main Compressor	3/4 HP (R404A)
Hopper Cooling Compressor	1/6 HP (R134a)
Drive Motor	1/2 HP (750 W)
Hertz	60 Hz
Plug type	NEMA L5-20P

## Distributed By:

**DONPER** USA

Donper USA  
500 Stonegate Dr.  
Katy, TX 77494

1-844-366-7371  
sales@donperusa.com  
www.donperusa.com