

NEWTON
COMMERCIAL

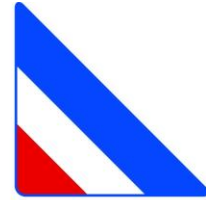

classic car interior trim

TRIUMPH TR2/3/3A/3B TRIM CATALOGUE

ISSUE DATE: MARCH 2016



TR2
1953 - 1955



TR3A/B
1957 - 1962



TR3
1955 - 1957

EASTLANDS INDUSTRIAL ESTATE, LEISTON, SUFFOLK. IP16 4LL.

TEL: 0044 (0) 1728 832880 FAX: 0044 (0) 1728 832810

WEB SITE: www.newtoncomm.co.uk

E-MAIL: sales@newtoncomm.co.uk

BRIEF HISTORY OF TR2-3

Produced by The Standard Motor Company as a development of the unsuccessful TR1/20T prototype, introduced at the 1952 London Motor Show. The **TR2** was launched in 1953 and is regarded as the first of the true Triumph sports cars. The pressed steel body was mounted on a ladder type chassis with independent coil sprung suspension at the front & leaf springs on a live axle at the rear. Steel wheels were standard with wires as an option. Drum brakes were fitted all round. The 1991cc Standard Vanguard 4 cylinder in line engine (used throughout the TR2/3/3A range) with a 4 speed manual gearbox producing 90 BHP (overdrive was available on top gear). Notably the car became well liked in the USA, becoming Triumphs best-selling car as well as being the lowest priced British car able to exceed 100mph. In 1955 the **TR2** was replaced by the **TR3**, essentially an upgrade which was produced until the summer of 1957.



The **TR3** offered an increase in power to 95BHP with carburettor changes (later 100BHP due to cylinder head and manifold modifications) and with overdrive available on the top three gears. The other significant improvement came after the first 4408 cars when the front drum brakes were replaced by disc brakes. (Making Triumph the first volume sports car manufacturer to use disc brakes) The list of factory optional extras consisted of seatbelts, overdrive, wire wheels, steel hardtop, occasional rear seat, radio, heater and leather upholstery. Still maintaining its popularity overseas to the extent that of the 13,377 **TR3s** produced, only 1286 were sold in the UK.



September 1957 saw the launch of the TR3 update which among other improvements included the wider front radiator grill, a lockable boot handle & exterior door handles.

This update was unofficially called the '**TR3A**' which was built between 1957 and 1962. However, such was the success of the TR3A that the original body panel moulds began to wear out. This resulted in a further facelift model where the new panel pressings included raised hinge & door handle fixing points along with a redesigned rear floor section. (This facelift was after commission No. TS60001)

The TR4 (Basically a re-bodied TR3) was introduced in August 1961 but was initially not well received in the USA.

Triumph decided to re-introduce the TR3 as a stop gap from March 1962 running alongside TR4 production. This was designated **TR3B** using the TR3 engine & a TR4 gearbox (4 synchro) for commission Nos 'TSF' and later cars used the TR4 engine (2138cc) & 4 synchro gearbox for commission Nos 'TCF'.

Production of the TR3B ended in October 1962.

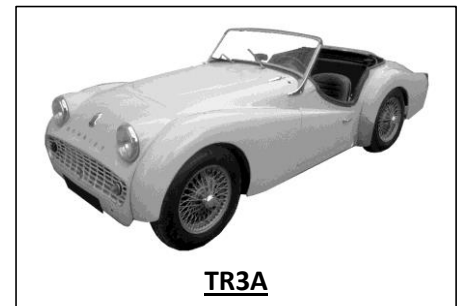

INTERIOR TRIM

The interior trim for TR2 was fairly basic, with upgrades in seats, carpet design and trim panels largely following changes in model/body modifications through the TR3 range. Generally as follows.

SEATS

TR2 - Sheet metal seat frame (both seats fixed), spring case on the base with 'horsehair' paddings under the seat covers. Seat covers originally vinyl, three pleats surrounded by a horseshoe design with self-coloured piping.

TR3 - (Up to TS22013) used the same design seat but with a fixed drivers & a folding passenger seat allowing access to the optional rear seat. Most seats featured Cream or White piping. Leather was offered as a factory option. See the 'Original Colours Available' chart in each parts list in this catalogue)

TR3A - (TS22014 to end of production) front seat covers redesigned with horizontal flutes (1 fixed & 1 folding seat), optional rear seat (to TS60000 had a curved front edge) now consisted of a base assembly only. All seats had white piping.

The rear seat from TS60001 to end of production had a straight front edge. Again, leather was offered as a factory option. TR3B seats were identical to TR3A seats.

PANELS

TR2 - (TS1 - 8636) Door panels were padded, no piping at the top, straight edged pocket opening with a flocked pocket assembly behind. Rear quarter panels had no padding & no piping. Wheel arch covers had self-coloured piping with a felt padding underneath. Rear Cockpit panel had no padding, made from plain fibreboard, creased to give fold points, covered in vinyl/leathercloth & with a shaped metal bracket fixed vertically at the back of the board.

TR3 - (TS8637 - 22013) Door panels and rear quarter panels were the same as TR2. Wheel arch covers were the same shape as TR2 but with white piping (For most colours). The rear cockpit panel was a painted & grained board with an embossed pattern in its surface & creased at fold points.

TR3A - (TS22014 - approx. 35350) Door panels were padded with white piping along top edge, kidney shaped pocket opening & a flocked pocket behind. Rear quarter panels were padded with white piping along top edges. Wheel arch covers were white piped. The rear cockpit panel changed for this model. A vinyl horizontal sewn flute design with white piping around the wheel arch cut outs. The sewn cover was trimmed (with a wadding padding underneath) over a plywood lower panel riveted to a shaped metal top. This assembly was held in place with a single upper bracket & two lower brackets. (As were the cockpit panels of all subsequent models).

TR3A - (TS approx. 35351 - TS60000) Door panels, rear quarter panels & wheel arch covers were the same as the previous model. The rear cockpit panel was changed to simplify its construction. Now on a one piece moulded hardboard, the padded fluted design of the previous model was reproduced using high frequency welding. White piping was again used around the wheel arch cut outs.

TR3A – (TS60001 – 83572) and **TR3B** – (TSF1 – 530) & (TCF1 – 2804). This model was produced from the re-tooled body panels resulting in a 'Facelift' model with a revised flat rear floor. The door panels had a rounded lower rear corner, otherwise similar to previous model. Rear quarter panel as previous model. Re-designed wheel arch cover with white piping. The rear cockpit panel was similar in construction to the previous model but with a larger cut out in the board at the middle of its bottom edge to clear the re-designed body.



TR2 INTERIOR
Matador Red vinyl with matador red piping.



TR3 INTERIOR
Cherokee red vinyl with white piping.



TR3A INTERIOR
Black vinyl with white piping.

CARPETS - Originally there were three basic styles of carpet set as follows;

TR2 – 3 (TS1 – 22013)

Front footwell mats had a heelmat on the driver's side along with a small kick pad on the driver's scuttle carpet. The front tunnel covering was made in three sections in an effort to follow the tunnel contours. All floor mats & front edge of tunnel carpets were bound. Originally supplied in wool only.

TR3A (TS22014 – 60000)

Similar to previous model – simplified front tunnel carpet & redesigned rear area. Originally supplied in wool up to TS35350, Then in Nylon loop pile up to TS60000.

TR3A/B – (TS60001 on)

Similar to the previous model but with a redesigned rear area due to new body tooling. Originally supplied with Nylon loop pile carpet.

BOOT TRIM

TR2 Was fitted with a Boot Bulkhead board, held in place with self-tapping screws & cup washers. This board was painted to match the body colour up to end of TR3 (TS22013), after which they were all painted black. We only offer black.

Boot Floor Mats were originally carpet with bound edges to match the main carpet set (Up to TS22013). Cars after this (TR3A&B) all had boot floor mats made from black Hardura. (We can supply carpet if required)

The carpets sets offered in this catalogue all follow the original design for each model and are currently available only in a tufted or a fibre bonded nylon automotive grade carpet with same coloured binding or, if required please enquire about a contrasting coloured binding.

The following pages show all the trim items available for each model, indicating commission numbers and build dates to help decide what should be correct for your car.

TR2
AUG 1953 – OCT 1955
COMMISSION Nos TS1 – TS8636

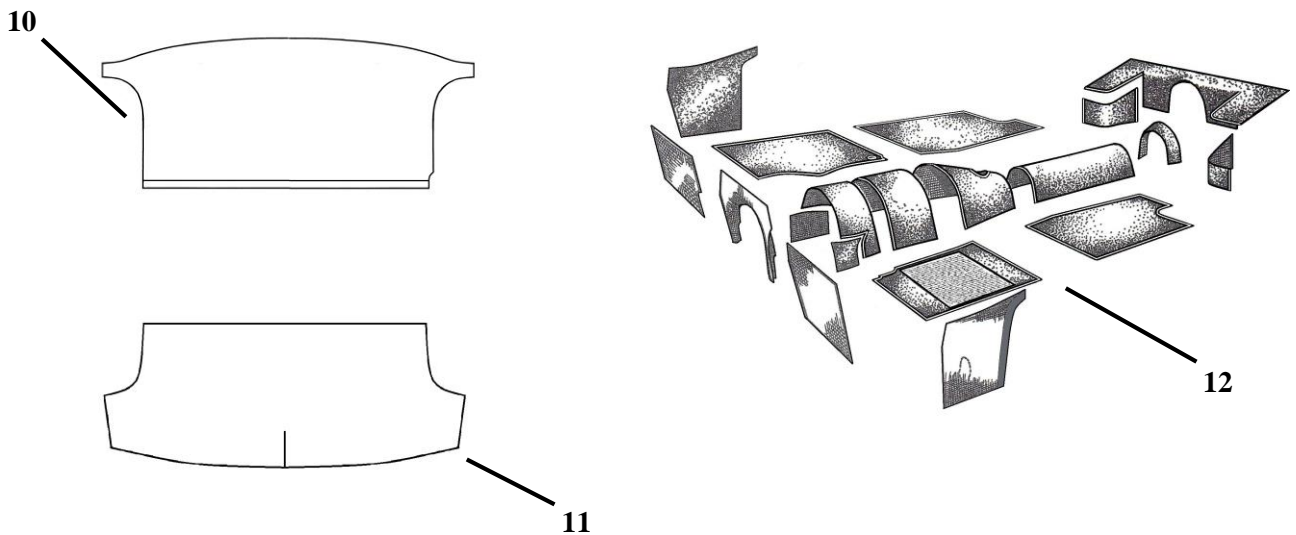
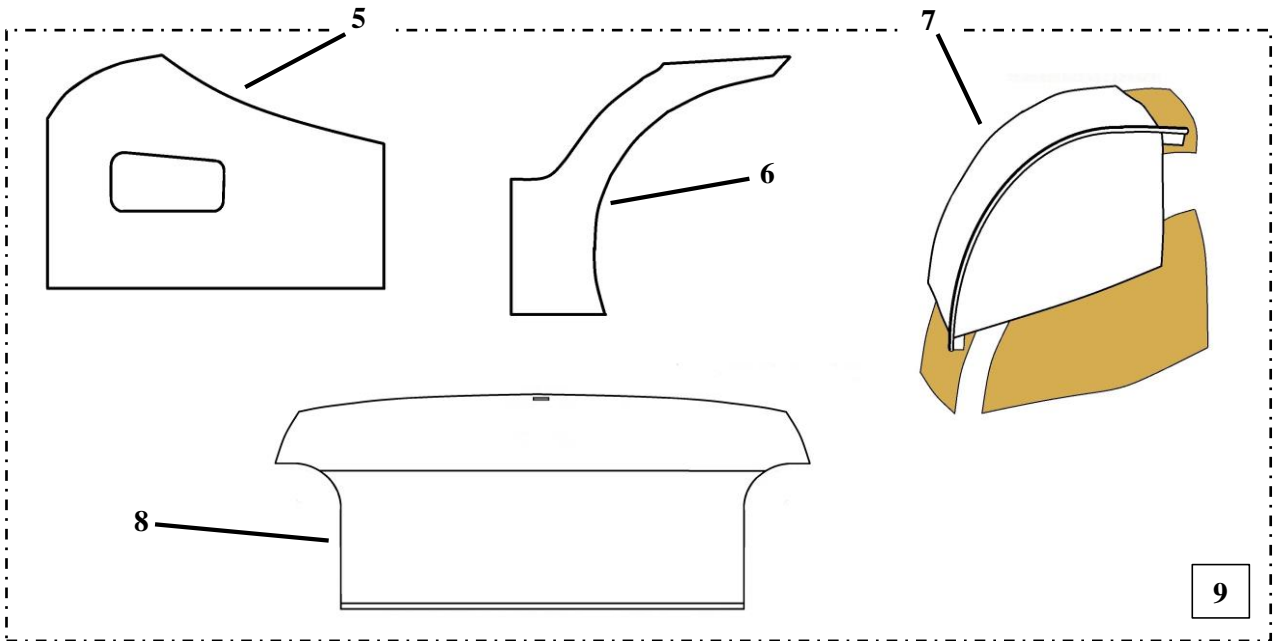
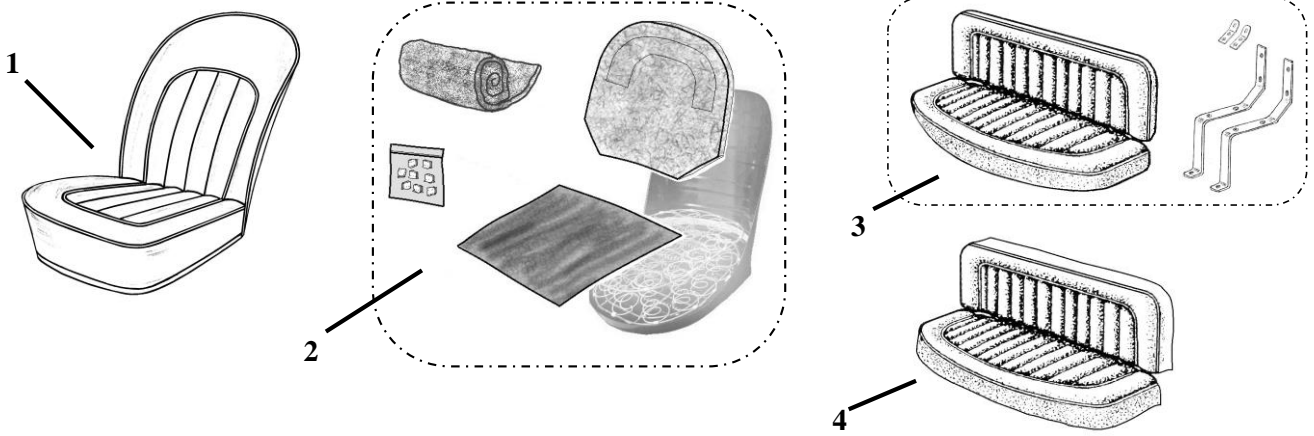

TR2
AUG 1953 – OCT 1955
 COMMISSION Nos TS1 – TS8636

<u>Diag. No</u>	<u>Part Number</u>	<u>Description</u>
1	SC3402	Seat Cover Kit – Vinyl – Both seats.
1	SC3403	Seat Cover Kit – Leather – Both seats.
NOTE; Originally both seats were fixed – piping was self-coloured on TR2.		
2	RFK258	Seat Padding Kit – For 2 seats.
3	S3420	Complete Occasional Rear Seat Assembly – Vinyl. (Includes mounting brackets)
3	S3425	Complete Occasional Rear Seat Assembly – Leather. (Includes mounting brackets)
4	SC3420	Occasional Rear Seat Covering Kit – Vinyl.
4	SC3425	Occasional Rear Seat Covering Kit – Leather.
NOTE; Although rear seats are offered as an option here, they were NOT originally available on this model.		
5	DP2500	Door Panels – Pair (Includes fitted flocked pocket).
6	WA2500	Rear Quarter Panels – Pair.
7	WAC2500	Wheel Arch Covers – Pair (Includes felt padding).
8	CP2508	Rear Cockpit Panel – (Includes fitted rear central metal fixing bracket).
9	BTK3200	Trim Panel Kit – 7 Piece – (Includes items 5, 6, 7 & 8 above).
NOTE; For other Panel Kit options - See Pages 14, 15 & 16		

<u>SEAT & TRIM PANEL - ORIGINAL COLOURS AVAILABLE</u>			
NOTE; All pipings were originally self-coloured			
<u>COLOUR CODE</u>	<u>DESCRIPTION</u>	<u>COLOUR CODE</u>	<u>DESCRIPTION</u>
A	BLACK (STAG GRAIN)	F	TAN (CINNAMON)
M	RED (CHEROKEE RED – BRIGHT)	D	BEIGE (T-TYPE BEIGE)
M2	RED (MATADOR RED)	D2	STONE (DOESKIN)
MB	MIDNIGHT BLUE	P	GREY
OTHER COLOURS ARE AVAILABLE – PLEASE ENQUIRE.			

<u>BOOT TRIM</u>		
10	PT2500A	Boot Bulkhead Panel – (Painted & grained fibreboard – Black only).
NOTE; Originally this part was painted to match the body colour, you can overspray to your colour choice.		
11	CK3420	Boot Floor Mat – Carpet to match main carpet set – bound edges.
<u>CARPET SETS</u>		
12	CK3430	Carpet Set – LHD – Nylon tufted or fibre bonded with matching binding.
12	CK3431	Carpet Set – RHD – Nylon tufted or fibre bonded with matching binding.

<u>CARPET COLOURS</u>			
<u>COLOUR CODE</u>	<u>DESCRIPTION & TYPE</u>	<u>COLOUR CODE</u>	<u>DESCRIPTION & TYPE</u>
A	BLACK - (TUFTED)	B	BLUE - (FIBRE BONDED)
F	AUTUMN LEAF - (TUFTED)	M	RED - (TUFTED)
P	GREY - (FIBRE BONDED)		

PLEASE NOTE; - OTHER COLOURS ARE AVAILABLE – PLEASE ENQUIRE.

TR3
OCT 1955 – AUG 1957
COMMISSION Nos TS8637 – TS22013

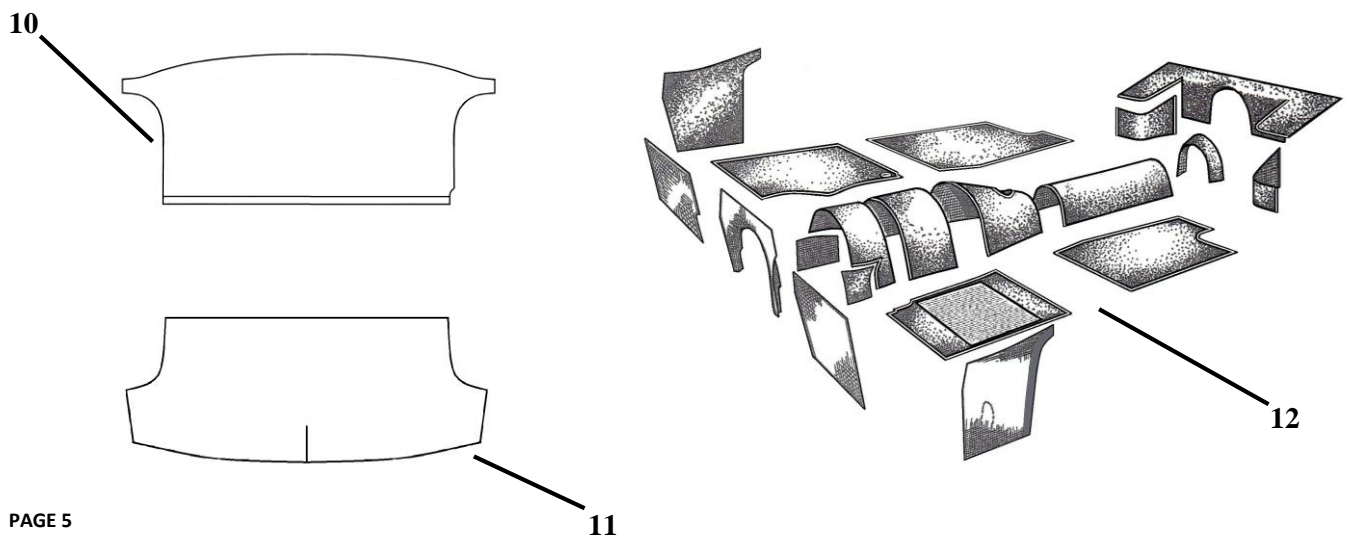
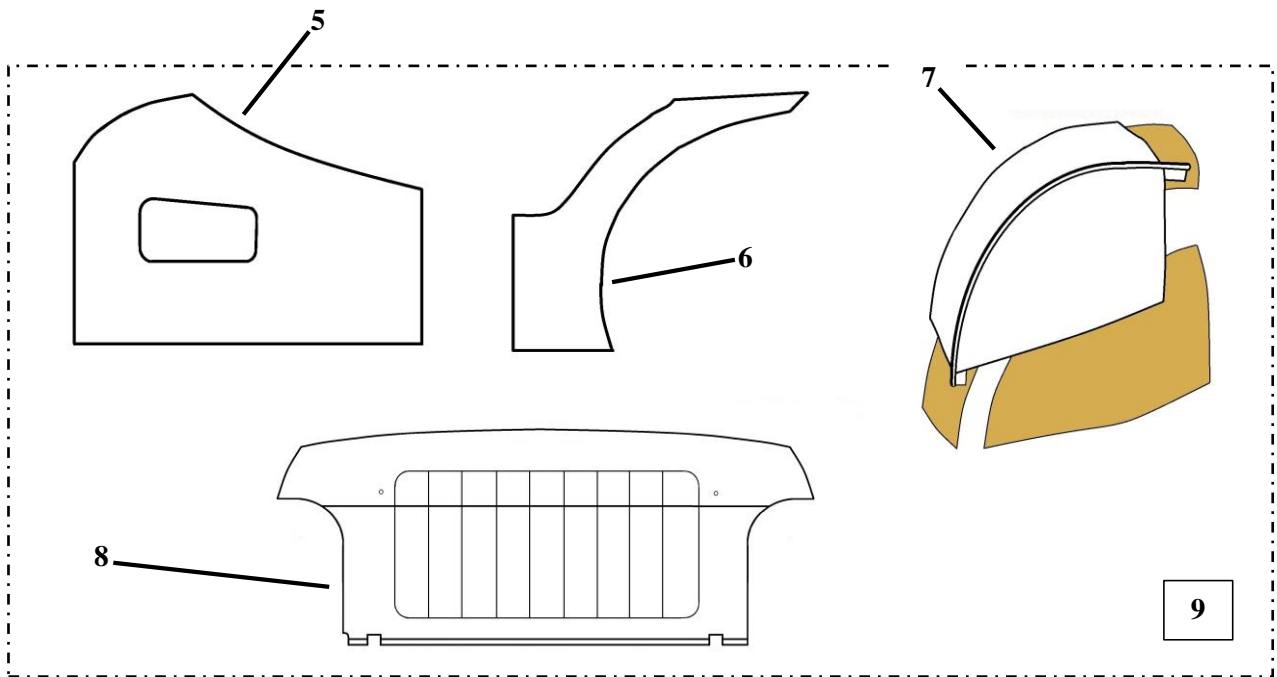
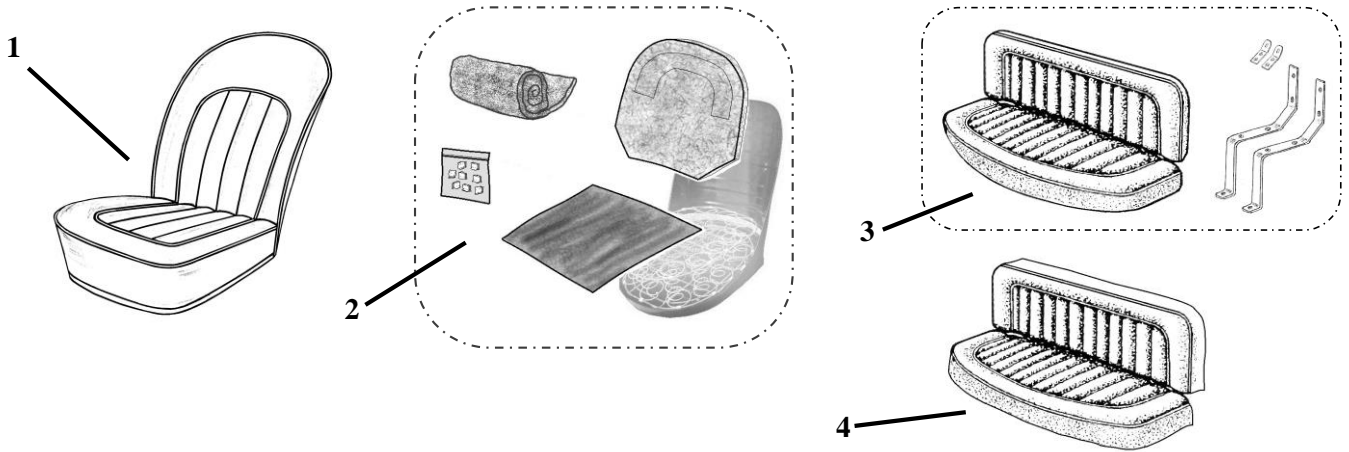

TR3
OCT 1955 – AUG 1957
 COMMISSION Nos TS8637 – TS22013

<u>Diag. No</u>	<u>Part Number</u>	<u>Description</u>
1	SC3404	Seat Cover Kit – Vinyl – Both seats.
1	SC3405	Seat Cover Kit – Leather – Both seats.
NOTE; Originally the driver's seat was fixed & passenger seat was folding – contrasting piping on most colours, see chart below.		
2	RFK258	Seat Padding Kit – For 2 seats.
3	S3420	Complete Occasional Rear Seat Assembly – Vinyl. (Includes mounting brackets)
3	S3425	Complete Occasional Rear Seat Assembly – Leather. (Includes mounting brackets)
4	SC3420	Occasional Rear Seat Covering Kit – Vinyl.
4	SC3425	Occasional Rear Seat Covering Kit – Leather.
NOTE; Rear seats were offered as a Factory optional extra – hence the need for a folding front seat to allow access.		
5	DP2500	Door Panels – Pair (Includes fitted flocked pocket).
6	WA2500	Rear Quarter Panels – Pair.
7	WAC2510	Wheel Arch Covers – Pair (Includes felt padding).
8	CP2509	Rear Cockpit Panel – (Black painted & grained, creased fibreboard)
NOTE; Originally the Rear Cockpit Panel was supplied black painted or to match the rest of the interior trim, our black panels can be over painted with a suitable automotive spray paint or a domestic colour matched emulsion paint using a spray application.		
9	BTK3201	Trim Panel Kit – 7 Piece (Includes items 5,6,7 & 8 above)
NOTE; For other Panel Kit options – See Pages 14, 15 & 16		

SEAT & TRIM PANEL – ORIGINAL COLOURS AVAILABLE

NOTE; Generally a White contrasting piping was used on seats & wheel arch covers with the exception of some neutral colours as shown below right.

<u>COLOUR CODE</u>	<u>DESCRIPTION</u>	<u>COLOUR CODE</u>	<u>DESCRIPTION</u>
AW	BLACK/WHITE	F	TAN (CINNAMON)
MW	RED(CHEROKEE RED)/WHITE	D	BEIGE (T – TYPE BEIGE)
M2W	RED(MATADOR RED)/WHITE	D2	STONE (DOESKIN)
MBW	MIDNIGHT BLUE/WHITE	P	GREY

OTHER COLOURS ARE AVAILABLE – PLEASE ENQUIRE

BOOT TRIM

10	PT2500A	Boot Bulkhead Panel – (Painted & grained fibreboard – Black only).
NOTE; Originally this part was painted to match the body colour, you can overspray to your colour choice.		
11	CK3420	Boot Floor Mat – Carpet to match main carpet set – bound edges.
<u>CARPET SETS</u>		
12	CK3430	Carpet Set – LHD – Nylon tufted or fibre bonded with matching binding.
12	CK3431	Carpet Set – RHD – Nylon tufted or fibre bonded with matching binding.

CARPET COLOURS

<u>COLOUR CODE</u>	<u>DESCRIPTION & TYPE</u>	<u>COLOUR CODE</u>	<u>DESCRIPTION & TYPE</u>
A	BLACK - (TUFTED)	B	BLUE - (FIBRE BONDED)
F	AUTUMN LEAF - (TUFTED)	M	RED - (TUFTED)
P	GREY - (FIBRE BONDED)		

PLEASE NOTE; - OTHER COLOURS ARE AVAILABLE – PLEASE ENQUIRE.

TR3A

SEPT 1957 – MID 1958

COMMISSION Nos TS22014 – APPROX. TS35350

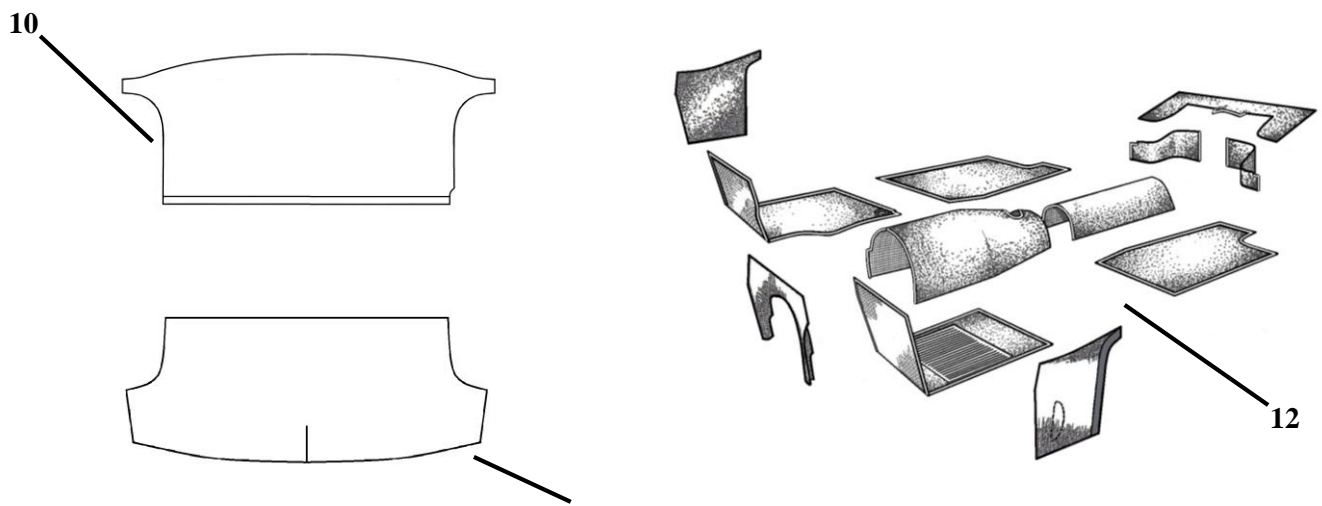
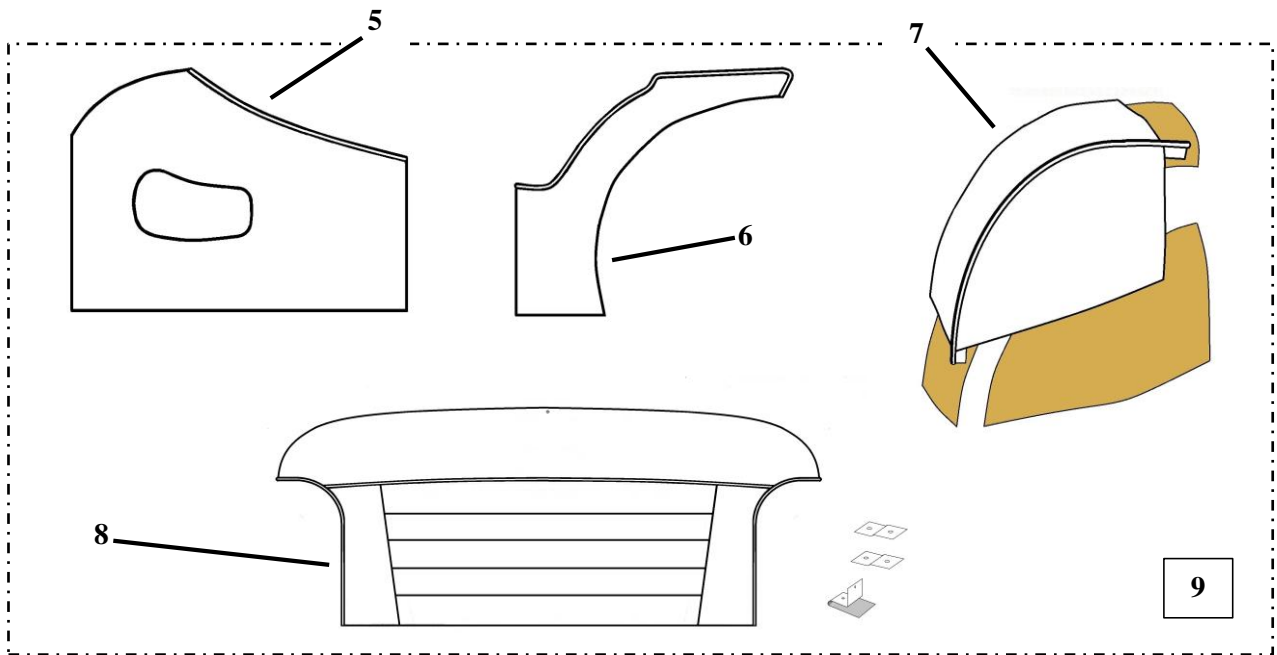
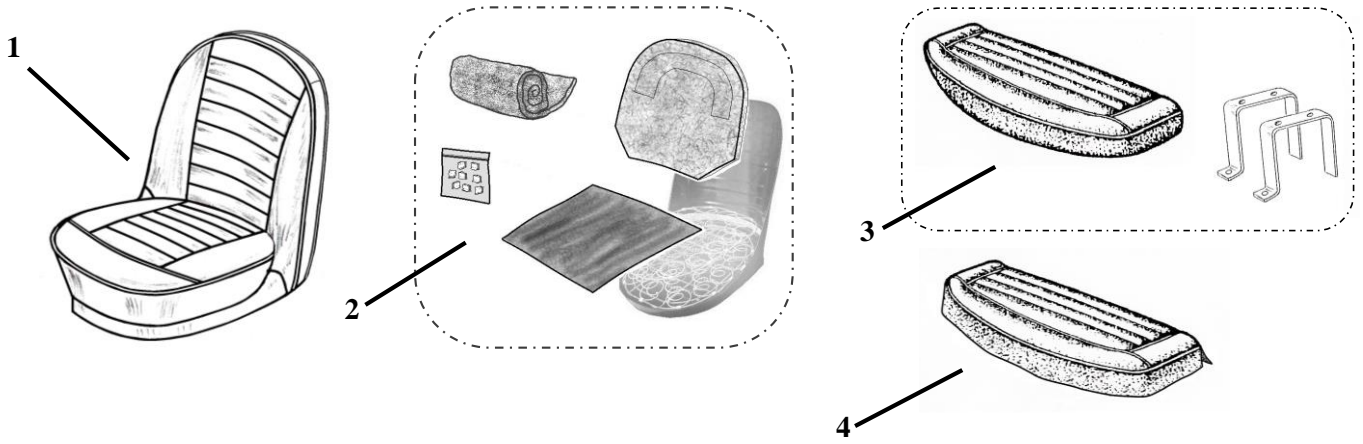

TR3A
SEPT1957 – MID 1958
 COMMISSION Nos TS22014 – APPROX. TS35350

<u>Diag. No</u>	<u>Part Number</u>	<u>Description</u>
1	SC3406	Seat Cover Kit – Vinyl – Both seats.
1	SC3407	Seat Cover Kit – Leather – Both seats.
NOTE; Originally the driver's seat was fixed & passenger seat was folding – contrasting piping on most colours, see chart below.		
2	RFK258	Seat Padding Kit – For 2 seats.
3	S3421	Complete Occasional Rear Seat Assembly – Vinyl. (Includes mounting brackets)
3	S3426	Complete Occasional Rear Seat Assembly – Leather. (Includes mounting brackets)
4	SC3421	Occasional Rear Seat Covering Kit – Vinyl.
4	SC3426	Occasional Rear Seat Covering Kit – Leather.
NOTE; Rear seat bases only, were offered as a Factory optional extra – hence the need for a folding front seat to allow access.		
5	DP2510	Door Panels – Pair (Includes fitted flocked pocket).
6	WA2510	Rear Quarter Panels – Pair.
7	WAC2510	Wheel Arch Covers – Pair (Includes felt padding).
8	CP2510	Rear Cockpit Panel – (Supplied with fixing brackets)
NOTE; As original, the Rear Cockpit Panel is made from a plywood lower & a metal top with a padded sewn covering considered enough to provide support as the rear seat back if fitted.		
9	BTK3202	Trim Panel Kit – 7 Piece (Includes items 5,6,7 & 8 above)
NOTE; For other Panel Kit options – See Pages 14, 15 & 16		

SEAT & TRIM PANEL – ORIGINAL COLOURS AVAILABLE

NOTE; Generally a White contrasting piping was used on seats, door tops, rear quarter panel tops & wheel arch covers with the exception of some neutral colours as shown below right.

<u>COLOUR CODE</u>	<u>DESCRIPTION</u>	<u>COLOUR CODE</u>	<u>DESCRIPTION</u>
AW	BLACK/WHITE	F	TAN (CINNAMON)
MW	RED(CHEROKEE RED)/WHITE	D	BEIGE (T – TYPE BEIGE)
M2W	RED(MATADOR RED)/WHITE	D2	STONE (DOESKIN)
MBW	MIDNIGHT BLUE/WHITE	P	GREY

OTHER COLOURS ARE AVAILABLE – PLEASE ENQUIRE

BOOT TRIM

10	PT2500A	Boot Bulkhead Panel – (Painted & grained fibreboard – Black only).
NOTE; From commission No TS22014 onwards this part was originally only supplied in a black finish.		
11	CK3426	Boot Floor Mat –Black Hardura – unbound edges. (As original)
<u>CARPET SETS</u>		
12	CK3434	Carpet Set – LHD – Nylon tufted or fibre bonded with matching binding.
12	CK3435	Carpet Set – RHD – Nylon tufted or fibre bonded with matching binding.

CARPET COLOURS

<u>COLOUR CODE</u>	<u>DESCRIPTION & TYPE</u>	<u>COLOUR CODE</u>	<u>DESCRIPTION & TYPE</u>
A	BLACK - (TUFTED)	B	BLUE - (FIBRE BONDED)
F	AUTUMN LEAF - (TUFTED)	M	RED - (TUFTED)
P	GREY - (FIBRE BONDED)		

PLEASE NOTE; - OTHER COLOURS ARE AVAILABLE – PLEASE ENQUIRE.

TR3A
MID 1958 – SEPT 1959
COMMISSION Nos APPROX. TS35351 – TS60000

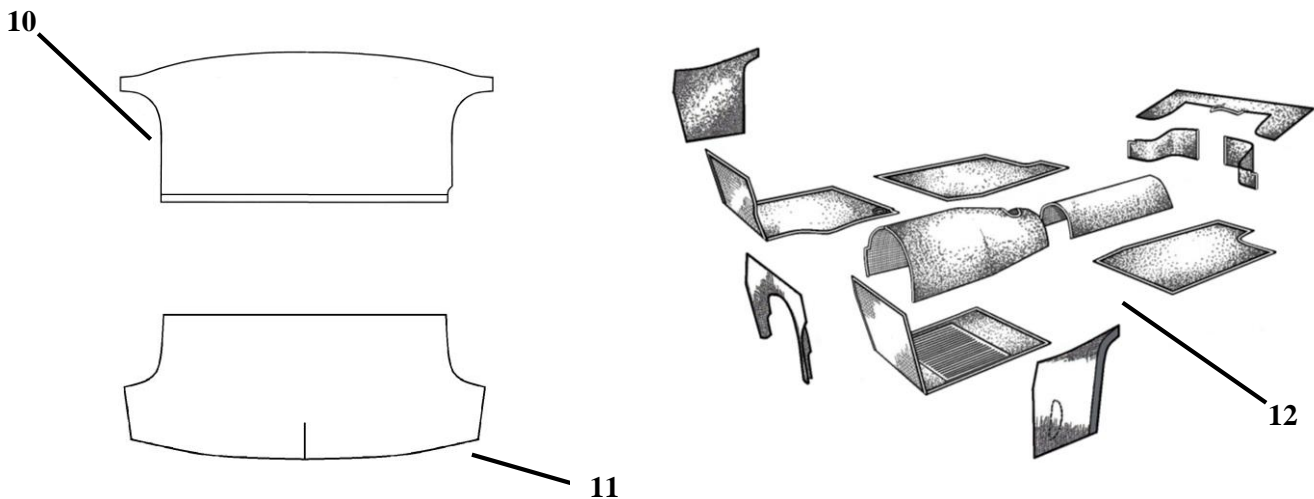
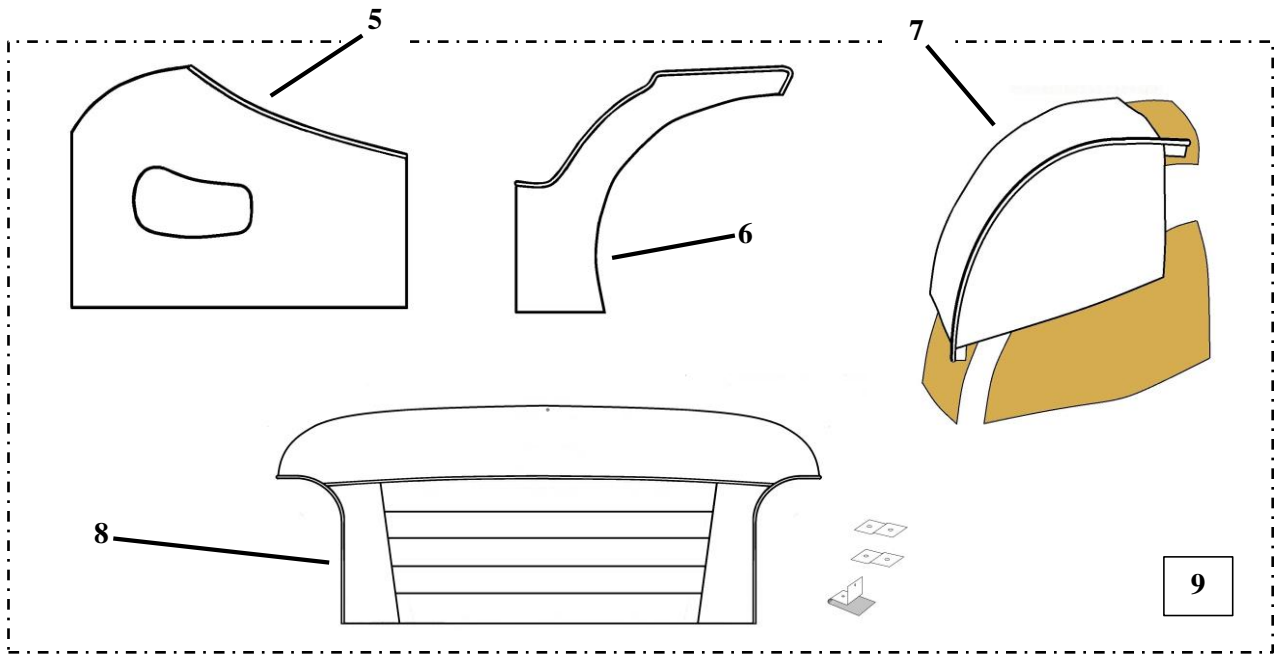
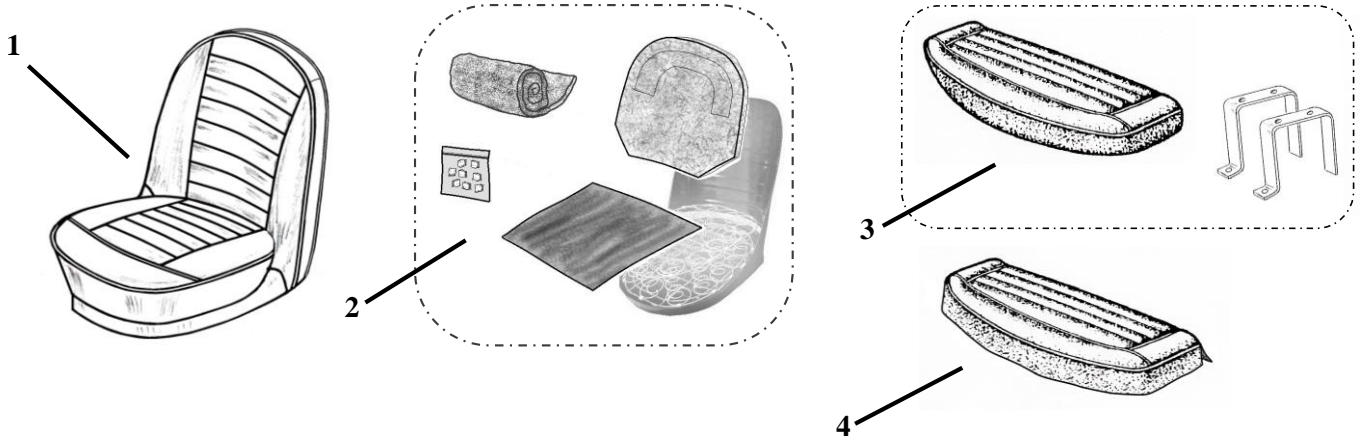

TR3A
MID 1958 – SEPT 1959
 COMMISSION Nos APPROX. TS35351 – TS60000

<u>Diag. No</u>	<u>Part Number</u>	<u>Description</u>
1	SC3406	Seat Cover Kit – Vinyl – Both seats.
1	SC3407	Seat Cover Kit – Leather – Both seats.
NOTE; Originally the driver's seat was fixed & passenger seat was folding – contrasting piping on most colours, see chart below.		
2	RFK258	Seat Padding Kit – For 2 seats.
3	S3421	Complete Occasional Rear Seat Assembly – Vinyl. (Includes mounting brackets)
3	S3426	Complete Occasional Rear Seat Assembly – Leather. (Includes mounting brackets)
4	SC3421	Occasional Rear Seat Covering Kit – Vinyl.
4	SC3426	Occasional Rear Seat Covering Kit – Leather.
NOTE; Rear seat bases only, were offered as a Factory optional extra – hence the need for a folding front seat to allow access.		
5	DP2510	Door Panels – Pair (Includes fitted flocked pocket).
6	WA2510	Rear Quarter Panels – Pair.
7	WAC2510	Wheel Arch Covers – Pair (Includes felt padding).
8	CP2520	Rear Cockpit Panel – (Supplied with fixing brackets)
NOTE; The rear cockpit panel was originally made from a moulded hardboard panel with a covering of a similar design to the previous model but the lines were heat welded not sewn. Due to manufacturing restrictions our panels are made from a hardboard lower section with a shaped metal top to achieve the original shape. In all other respects the original design is followed.		
9	BTK3203	Trim Panel Kit – 7 Piece (Includes items 5,6,7 & 8 above)
NOTE; For other Panel Kit options – See Pages 14, 15 & 16		

SEAT & TRIM PANEL – ORIGINAL COLOURS AVAILABLE

NOTE; Generally a White contrasting piping was used on seats, door tops, rear quarter panel tops & wheel arch covers with the exception of some neutral colours as shown below right.

<u>COLOUR CODE</u>	<u>DESCRIPTION</u>	<u>COLOUR CODE</u>	<u>DESCRIPTION</u>
AW	BLACK/WHITE	F	TAN (CINNAMON)
MW	RED(CHEROKEE RED)/WHITE	D	BEIGE (T – TYPE BEIGE)
M2W	RED(MATADOR RED)/WHITE	D2	STONE (DOESKIN)
MBW	MIDNIGHT BLUE/WHITE	P	GREY

OTHER COLOURS ARE AVAILABLE – PLEASE ENQUIRE

BOOT TRIM

10	PT2500A	Boot Bulkhead Panel – (Painted & grained fibreboard – Black only).
NOTE; From commission No TS22014 onwards this part was originally only supplied in a black finish.		
11	CK3426	Boot Floor Mat –Black Hardura – unbound edges. (As original)

CARPET SETS

12	CK3434	Carpet Set – LHD – Nylon tufted or fibre bonded with matching binding.
12	CK3435	Carpet Set – RHD – Nylon tufted or fibre bonded with matching binding.

CARPET COLOURS

<u>COLOUR CODE</u>	<u>DESCRIPTION & TYPE</u>	<u>COLOUR CODE</u>	<u>DESCRIPTION & TYPE</u>
A	BLACK - (TUFTED)	B	BLUE - (FIBRE BONDED)
F	AUTUMN LEAF - (TUFTED)	M	RED - (TUFTED)
P	GREY - (FIBRE BONDED)		

PLEASE NOTE; - OTHER COLOURS ARE AVAILABLE – PLEASE ENQUIRE.

TR3A

OCT 1959 – FEB 1962

COMMISSION Nos TS60001 – TS83572

TR3B

MAR 1962 – SEPT 1962

COMMISSION Nos TSF1 – TSF530 (TR3 ENGINE)

MAY 1962 – OCT 1962

COMMISSION Nos TCF1 – TCF2804 (TR4 ENGINE)

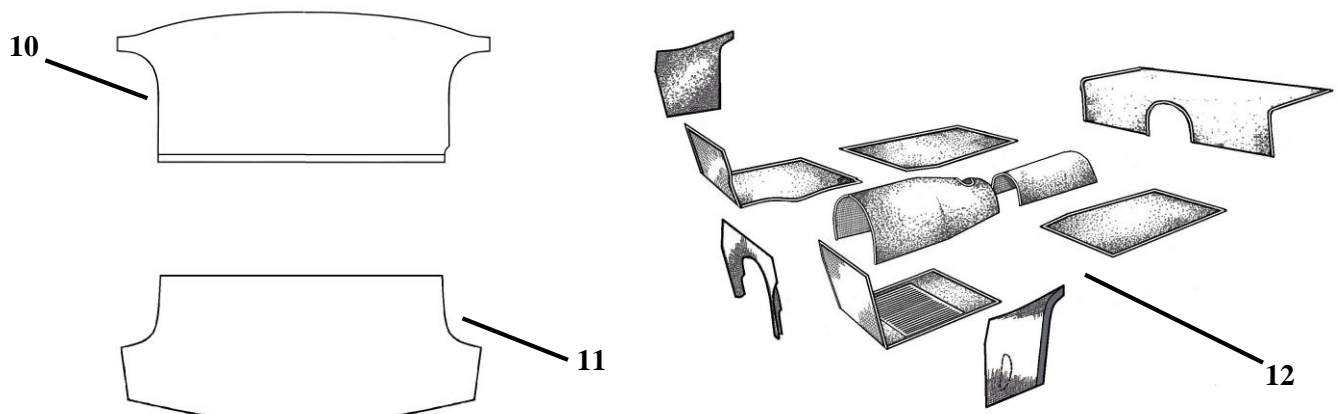
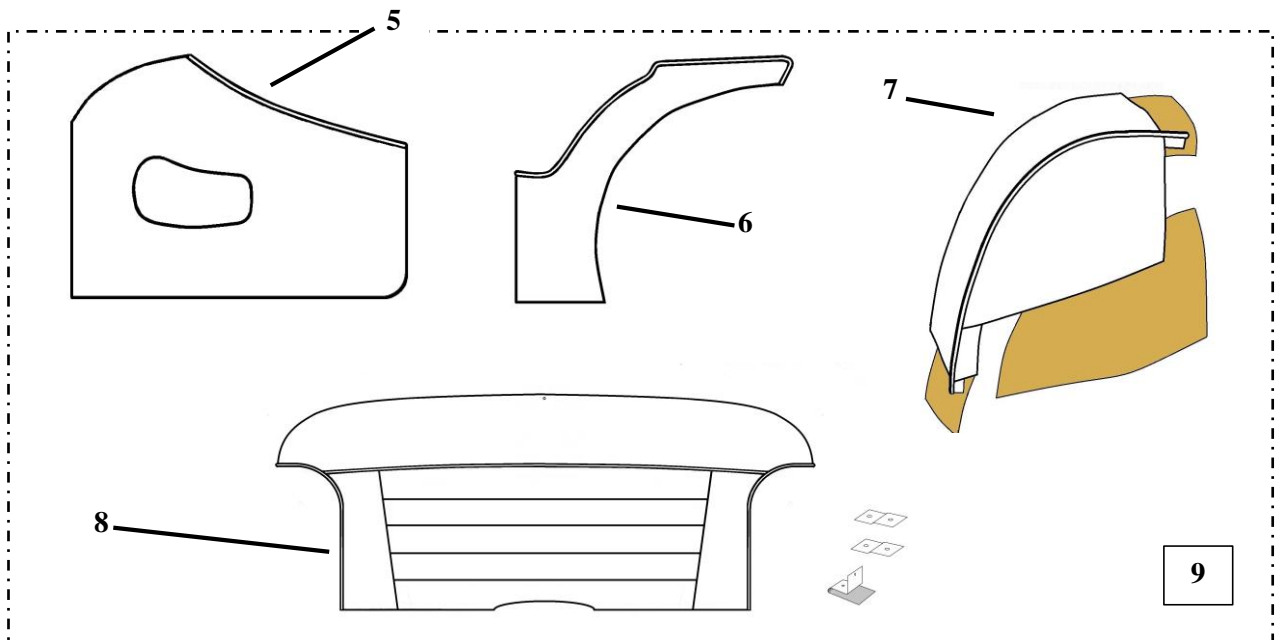
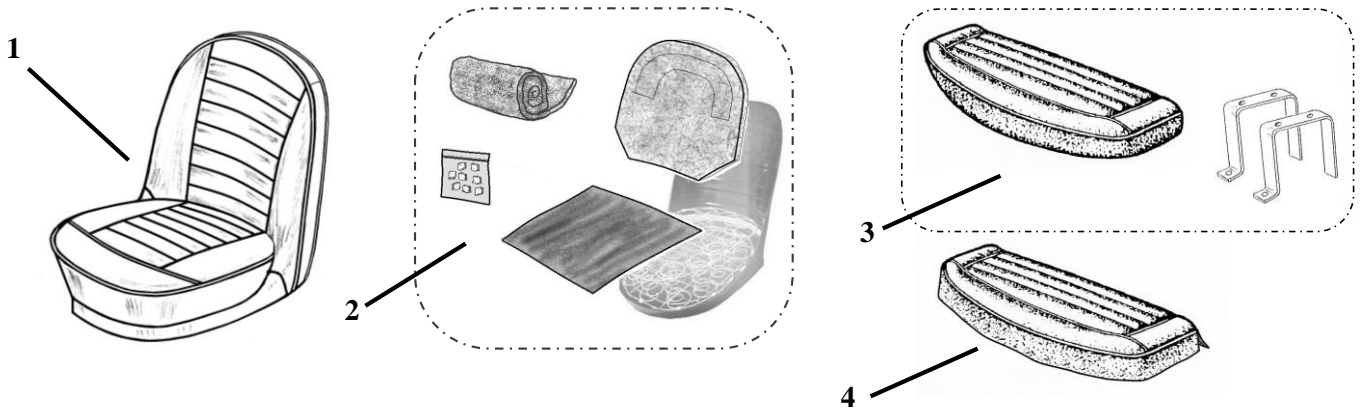

TR3A
OCT 1959 – FEB 1962
 COMMISSION Nos TS60001 – TS83572

TR3B
MAR 1962 – SEPT 1962
 COMMISSION Nos TSF1 – TSF530 (TR3 ENGINE)
MAY 1962 – OCT 1962
 COMMISSION Nos TCF1 – TCF2804 (TR4 ENGINE)

<u>Diag. No</u>	<u>Part Number</u>	<u>Description</u>
1	SC3406	Seat Cover Kit – Vinyl – Both seats.
1	SC3407	Seat Cover Kit – Leather – Both seats.
NOTE; Originally the driver's seat was fixed & passenger seat was folding – contrasting piping on most colours, see chart below.		
2	RFK258	Seat Padding Kit – For 2 seats.
3	S3422	Complete Occasional Rear Seat Assembly – Vinyl. (Includes mounting brackets)
3	S3427	Complete Occasional Rear Seat Assembly – Leather. (Includes mounting brackets)
4	SC3422	Occasional Rear Seat Covering Kit – Vinyl.
4	SC3427	Occasional Rear Seat Covering Kit – Leather.
NOTE; Rear seat bases only, were offered as a Factory optional extra – hence the need for a folding front seat to allow access.		
5	DP2520	Door Panels – Pair (Includes fitted flocked pocket).
6	WA2510	Rear Quarter Panels – Pair.
7	WAC2520	Wheel Arch Covers – Pair (Includes felt padding).
8	CP2530	Rear Cockpit Panel – (Supplied with fixing brackets)
NOTE; The rear cockpit panel was originally made from a moulded hardboard panel with a covering of a similar design to the previous model but the lines were heat welded not sewn. Due to manufacturing restrictions our panels are made from a hardboard lower section with a shaped metal top to achieve the original shape. In all other respects the original design is followed.		
9	BTK3204	Trim Panel Kit – 7 Piece (Includes items 5,6,7 & 8 above)
NOTE; For other Panel Kit options – See Pages 14, 15 & 16		

SEAT & TRIM PANEL – ORIGINAL COLOURS AVAILABLE

NOTE; Generally a White contrasting piping was used on seats, door tops, rear quarter panel tops & wheel arch covers with the exception of some neutral colours as shown below right.

<u>COLOUR CODE</u>	<u>DESCRIPTION</u>	<u>COLOUR CODE</u>	<u>DESCRIPTION</u>
AW	BLACK/WHITE	F	TAN (CINNAMON)
MW	RED(CHEROKEE RED)/WHITE	D	BEIGE (T – TYPE BEIGE)
M2W	RED(MATADOR RED)/WHITE	D2	STONE (DOESKIN)
MBW	MIDNIGHT BLUE/WHITE	P	GREY

OTHER COLOURS ARE AVAILABLE – PLEASE ENQUIRE

BOOT TRIM

10	PT2500A	Boot Bulkhead Panel – (Painted & grained fibreboard – Black only).
NOTE; From commission No TS22014 onwards this part was originally only supplied in a black finish.		
11	CK3426	Boot Floor Mat –Black Hardura – unbound edges. (As original)

CARPET SETS

12	CK3436	Carpet Set – LHD – Nylon tufted or fibre bonded with matching binding.
12	CK3438	Carpet Set – RHD – Nylon tufted or fibre bonded with matching binding.

CARPET COLOURS

<u>COLOUR CODE</u>	<u>DESCRIPTION & TYPE</u>	<u>COLOUR CODE</u>	<u>DESCRIPTION & TYPE</u>
A	BLACK - (TUFTED)	B	BLUE - (FIBRE BONDED)
F	AUTUMN LEAF - (TUFTED)	M	RED - (TUFTED)
P	GREY - (FIBRE BONDED)		

PLEASE NOTE; - OTHER COLOURS ARE AVAILABLE – PLEASE ENQUIRE.

TR2 – 3 – 3A/B ACCESSORIES – ALL MODELS

OVERMATS

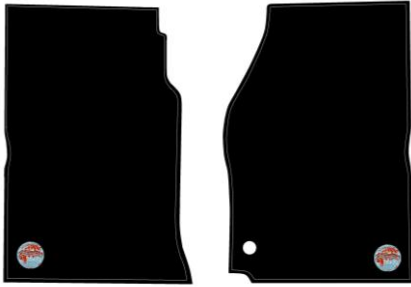

PART NUMBER

CK3437A

BLACK ONLY
NON SLIP RUBBER BACKING, BOUND
ALL ROUND PLUS A TRIUMPH LOGO.

PVC TOOL POUCH



PART NUMBER

PT4003

COLOURS AVAILABLE
A = BLACK
B = BLUE
M = RED

PVC TOOL ROLL

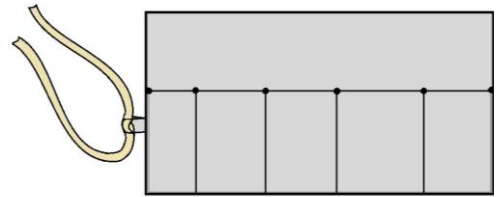

PART NUMBER

24731

AVAILABLE IN BLACK ONLY

HEAVY DUTY PVC TOOL ROLL WITH A TAPE
TIE - AS ORIGINAL.

DASHBOARD COVERING KITS

Originally all dashboards, centre instrument panel & glovebox lids were covered in leathercloth to match the colour of the seats & interior panels. We offer a choice of styles, vinyl or leather, in all colours as shown below.

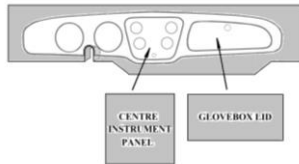

PART NUMBER

CC3408

LHD only kit with sewn in flap for steering
column recess.

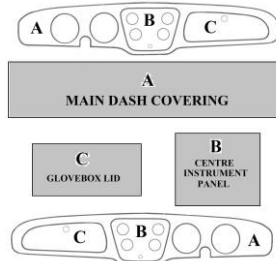

PART NUMBER

CC3409

LHD or RHD kit – plain material only.

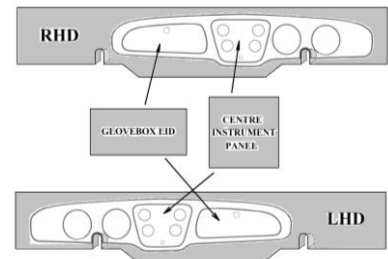

PART NUMBER

CC3411

LHD or RHD kit with two sewn flaps for
steering column.

Pictures above show alignment.

COCKPIT CAPPING KITS

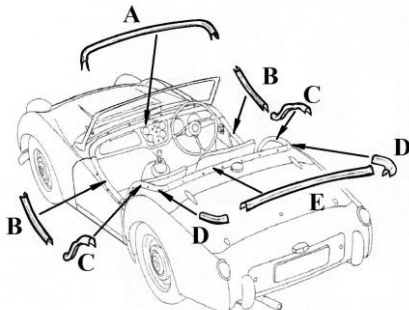

CC3400 – ALL VINYL
CC3406 – LEATHER KIT

KEY FOR LEATHER KIT AS
FOLLOWS

A = DASH RAIL (Leather)
B = DOOR CAPPINGS x 2 (Leather)
C = REAR QTR CAPS x2 (Leather)
D = REAR C/PIT ENDS x 2 (Vinyl)
E = REAR C/PIT RAIL (Vinyl)

HOOD FRAME COVER

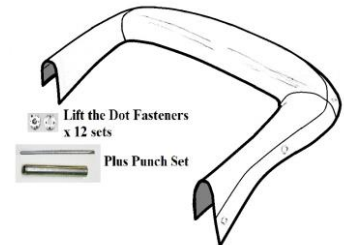

VT727

Available in Vinyl or Leather

COLOURS AVAILABLE FOR ALL ITEMS SHOWN ABOVE

COLOUR CODE	DESCRIPTION	COLOUR CODE	DESCRIPTION
A	BLACK (STAG GRAIN)	F	TAN (CINNAMON)
M	RED – (BRIGHT – CHEROKEE RED)	D	BEIGE (T-TYPE BEIGE)
M2	RED (MATADOR RED)	D2	STONE (DOESKIN)
MB	MIDNIGHT BLUE	P	GREY

OTHER COLOURS AVAILABLE – PLEASE ENQUIRE.

PLEASE NOTE: FOR LEATHER OPTIONS – PLEASE GIVE PART No + COLOUR CODE + L

e.g. VT727M2L = HOOD FRAME COVER IN RED LEATHER

TR2/3/3A/3B

PANEL KITS

STANDARD TRIM PANEL KIT – 6 PIECE

CONTENTS: DOOR PANELS (COMPLETE), REAR QUARTER PANELS & WHEEL ARCH COVERS
ALL TO ORIGINAL SPECIFICATION

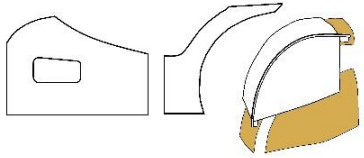
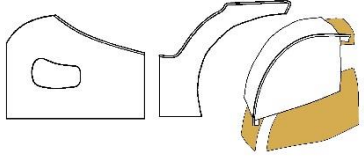
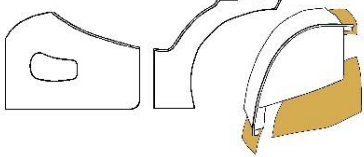
PART NUMBER	DESCRIPTION	DESIGN
ATK3200	TR2 (AUG 1953 – OCT 1955) Commission Nos TS1 – TS8636 TR3 (OCT 1955 – AUG 1957) Commission Nos TS8637 – TS22013	
ATK3202	TR3A (SEPT 1957 – SEPT 1959) Commission Nos TS22014 – TS60000	
ATK3204	TR3A (OCT 1959 – FEB 1962) Commission Nos TS60001 – TS83572 TR3B (MARCH 1962 – OCT 1962) All Commission Nos TSF and TCF	

STANDARD TRIM PANEL KIT – 7 PIECE

CONTENTS: DOOR PANELS (COMPLETE), REAR QUARTER PANELS, WHEEL ARCH COVERS & COCKPIT PANEL.

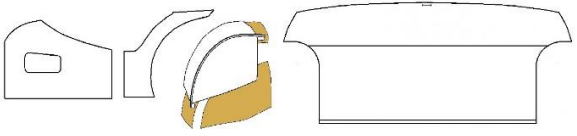
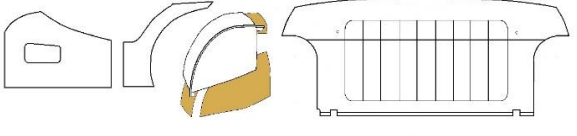
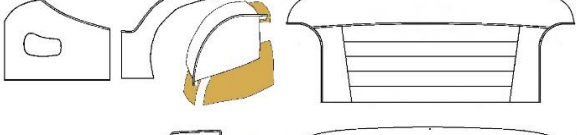
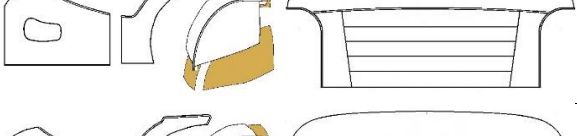
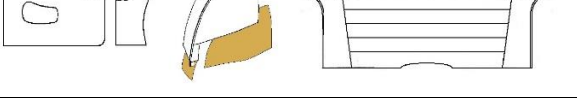
PART NUMBER	DESCRIPTION	DESIGN
BTK3200	TR2 (AUG 1953 – OCT 1955) Commission Nos TS1 – TS8636	
BTK3201	TR3 (OCT 1955 – AUG 1957) Commission Nos TS8637 – TS22013	
BTK3202	TR3A (SEPT 1957 – MID 1958) Commission Nos TS22014 – Approx. TS35350	
BTK3203	TR3A (MID 1958 – SEPT 1959) Commission No. Approx. TS35351 – TS60000	
BTK3204	TR3A (OCT 1959 – FEB 1962) Commission Nos TS60001 – TS83572 TR3B (MARCH 1962 – OCT 1962) All Commission Nos TSF and TCF	

DE LUXE TRIM PANEL KIT – 9 PIECE

CONTENTS: DOOR PANELS (COMPLETE), REAR QUARTER PANELS, WHEEL ARCH COVERS, COCKPIT PANEL, VINYL COCKPIT CAPPING KIT & UNIVERSAL DASHBOARD COVERING KIT.

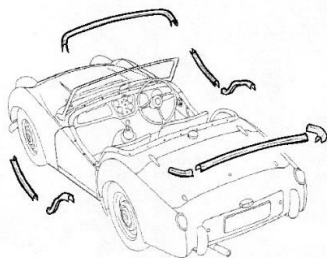

PART NUMBER
CC3400
COCKPIT COVERING KIT

**ALL DE LUXE KITS
INCLUDE THESE
PARTS**

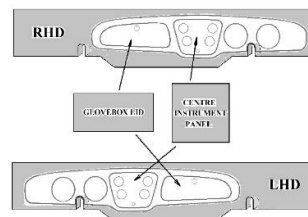

PART NUMBER
CC3411
DASHBOARD COVERING KIT

PART NUMBER	DESCRIPTION	DESIGN
DTK3200	TR2 (AUG 1953 – OCT 1955) Commission Nos TS1 – TS8636	
DTK3201	TR3 (OCT 1955 – AUG 1957) Commission Nos TS8637 – TS22013	
DTK3202	TR3A (SEPT 1957 – MID 1958) Commission Nos TS22014 – Approx. TS35350	
DTK3203	TR3A (MID 1958 – SEPT 1959) Commission Nos Approx. TS35351 – TS60000	
DTK3204	TR3A (OCT 1959 – FEB 1962) Commission Nos TS60001 – TS83572 TR3B (MARCH 1962 – OCT 1962) All Commission Nos TSF and TCF	

TRIM PANEL – ORIGINAL COLOURS AVAILABLE

NOTE; Generally a White contrasting piping was used on seats, door tops, rear quarter panel tops & wheel arch covers for TR3/3A/3B models, with the exception of some neutral colours as shown below right.

<u>COLOUR CODE</u>	<u>DESCRIPTION</u>	<u>COLOUR CODE</u>	<u>DESCRIPTION</u>
AW	BLACK/WHITE	F	TAN (CINNAMON)
MW	RED(CHEROKEE RED)/WHITE	D	BEIGE (T – TYPE BEIGE)
M2W	RED(MATADOR RED)/WHITE	D2	STONE (DOESKIN)
MBW	MIDNIGHT BLUE/WHITE	P	GREY

OTHER COLOURS ARE AVAILABLE – PLEASE ENQUIRE
PLEASE NOTE: NAMES IN BRACKETS SHOW THE MODERN COLOUR NAMES.

LEATHER COVERED TRIM PANEL KIT – 7 PIECE

CONTENTS: DOOR PANELS (COMPLETE), REAR QUARTER PANELS, WHEEL ARCH COVERS & COCKPIT PANEL.

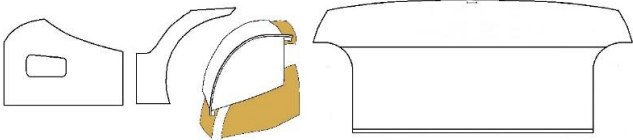
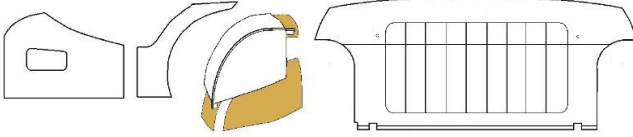
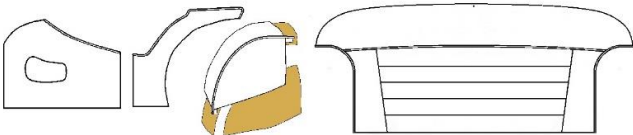
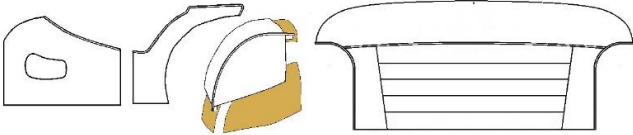
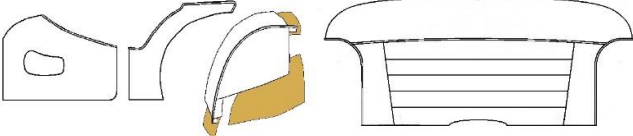
PART NUMBER	DESCRIPTION	DESIGN
CTK3200	TR2 (AUG 1953 – OCT 1955) Commission Nos TS1 – TS8636	
CTK3201	TR3 (OCT 1955 – AUG 1957) Commission Nos TS8637 – TS22013	
NOTE: REAR C/PIT PANEL IN THIS KIT NOT LEATHER COVERED – AS ORIGINAL STYLE – IF REQUIRED PLEASE ENQUIRE.		
CTK3202	TR3A (SEPT 1957 – MID 1958) Commission Nos TS22014 – APPROX. TS35350	 NOTE: REAR COCKPIT PLEATS SEWN – AS NORMAL FOR THIS MODEL.
CTK3203	TR3A (MID 1958 – SEPT 1959) Commission Nos Approx. TS35351 – TS60000	 NOTE: REAR COCKPIT PLEATS SEWN
CTK3204	TR3A (OCT 1959 – FEB 1962) Commission Nos TS60001 – TS83572 TR3B (MARCH 1962 – OCT 1962) All Commission Nos - TSF and TCF	 NOTE: REAR COCKPIT PLEATS SEWN

TRIM PANEL – ORIGINAL COLOURS AVAILABLE

NOTE; Generally a White contrasting piping was used on seats, door tops, rear quarter panel tops & wheel arch covers for TR3/3A/3B models, with the exception of some neutral colours as shown below right.

COLOUR CODE	DESCRIPTION	COLOUR CODE	DESCRIPTION
AW	BLACK/WHITE	F	TAN (CINNAMON)
MW	RED(CHEROKEE RED)/WHITE	D	BEIGE (T – TYPE BEIGE)
M2W	RED(MATADOR RED)/WHITE	D2	STONE (DOESKIN)
MBW	MIDNIGHT BLUE/WHITE	P	GREY

OTHER COLOURS ARE AVAILABLE – PLEASE ENQUIRE
PLEASE NOTE: NAMES IN BRACKETS SHOW THE MODERN COLOUR NAMES.

ARE YOU AWARE THAT **NEWTON COMMERCIAL** ALSO PRODUCES INTERIOR TRIM FOR THE FOLLOWING VEHICLES?

CLASSIC MINI

MORRIS MINOR

MG T – TYPE

MGB

MGF

MG MIDGET

A.H. SPRITE

TRIUMPH TR2 - 3

TRIUMPH TR4 – 6

TRIUMPH HERALD

TRIUMPH VITESSE

TRIUMPH SPITFIRE

TRIUMPH GT6

VW CLASSIC BEETLE

VW TYPE 2 VAN

VW TYPE 25 VAN

VW TYPE 4 VAN

VW KARMANN GHIA

VW GOLF Mk 1 & Mk11

VW SCIROCCO Mk1 & 11

VW CORRADO

LOTUS ELAN 62 – 73

PLUS OTHERS

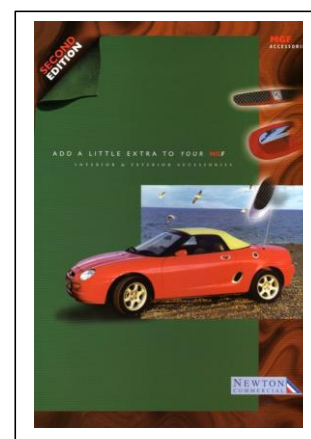
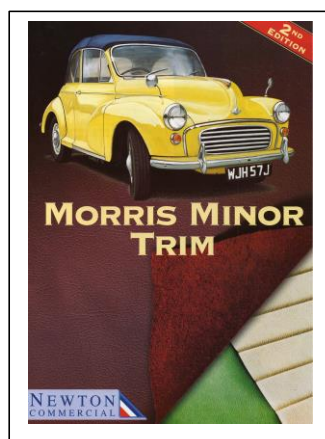
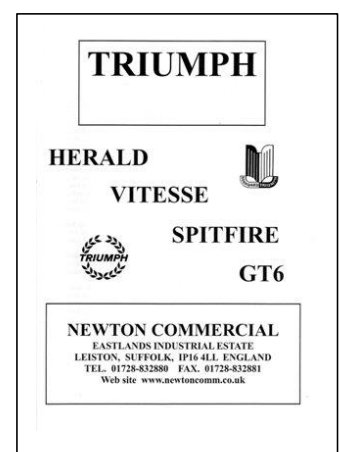

PLEASE VISIT OUR WEB SITE OR CONTACT OUR SALES TEAM FOR INFORMATION, CATALOGUES, COLOUR SAMPLES AND PRICES.

NEWTON COMMERCIAL
 EASTLANDS INDUSTRIAL ESTATE, LEISTON, SUFFOLK. IP16 4LL.
 TEL: 0044 (0) 1728 832880 FAX: 0044 (0) 1728 832810
 WEB SITE: www.newtoncomm.co.uk
 E-MAIL: sales@newtoncomm.co.uk