

2ND
EDITION

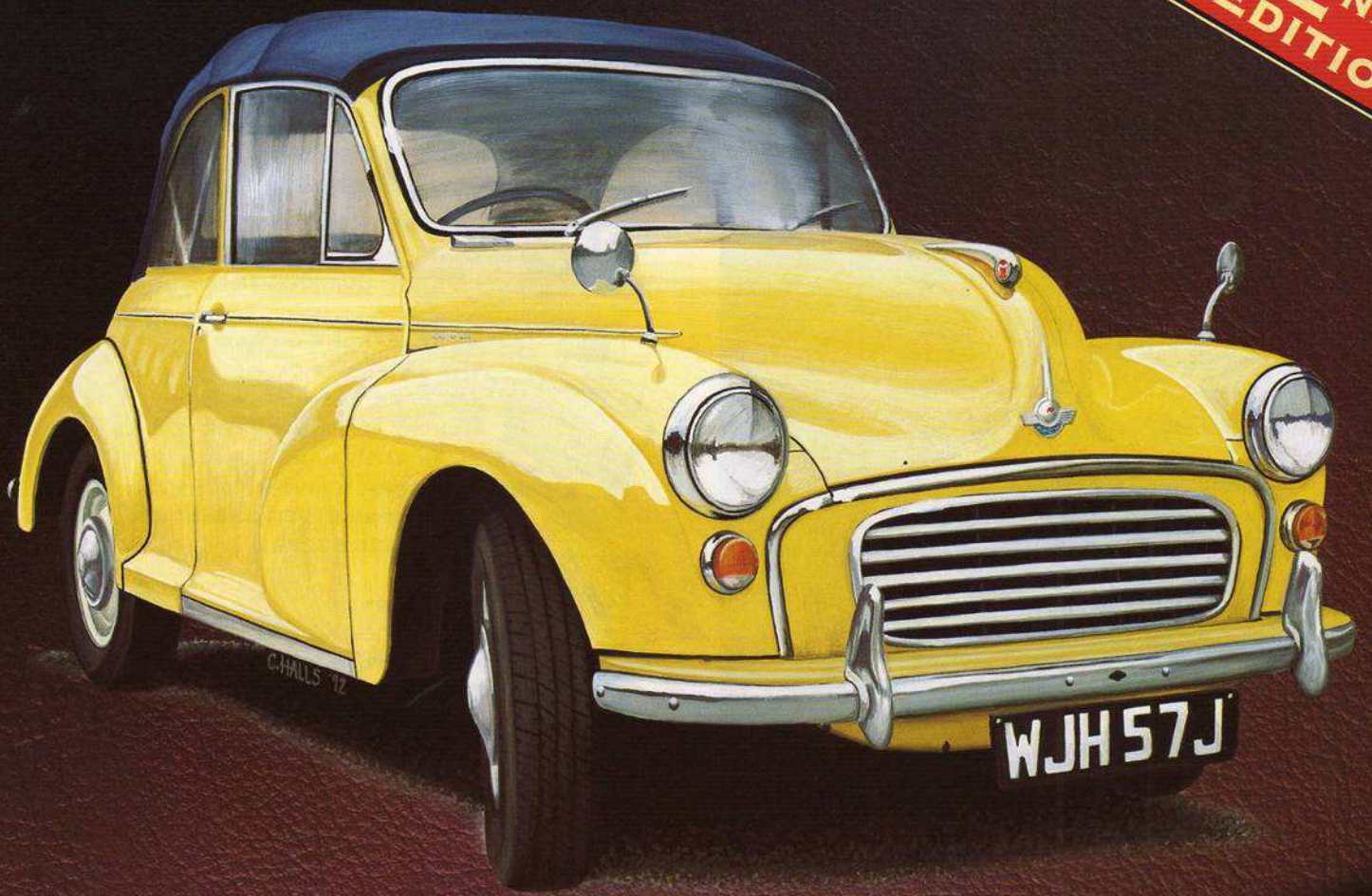

MORRIS MINOR TRIM

NEWTON
COMMERCIAL



CONTENTS

2	CONTENTS
3	INTRODUCTION AND ABOUT THIS BROCHURE
4	PICTORIAL PAGE 1
5	SUFFOLK RECLINING SEATS
6	MINOR MM SERIES 1949-53
7	MINOR MM SERIES 1949-53
8	MINOR SERIES II 1953-56
9	MINOR SERIES II 1953-56
10	MINOR 1956-59
11	MINOR 1956-59
12	MINOR 1960-62
13	MINOR 1960-62
14	MINOR 1962-64 'DUOTONE'
15	MINOR 1962-64 'DUOTONE'
16	MINOR 1964-71
17	MINOR 1964-71
18	MINOR VAN & PICK UP
19	MINOR VAN & PICK UP
20	ACCESSORIES
21	MORRIS MINOR INTERIOR PANELS
22	DELUXE CLASSIC CARPET SETS
23	MORRIS MINOR ACCESSORIES

ORDERING METHODS



BY POST TO: -
 NEWTON COMMERCIAL,
 EASTLANDS INDUSTRIAL ESTATE,
 LEISTON, SUFFOLK, IP16 4LL.



BY TELEPHONE OR FAX: -
 THE SALES OFFICE PHONE LINES
 ARE OPEN FROM 9.00-4.30PM
 MONDAY TO FRIDAY. THERE WILL
 BE AN ANSWERING SERVICE AT
 ALL OTHER TIMES.
TELEPHONE 01728 832880 OR
FAX 01728 832881



BY INTERNET: -
 YOU CAN E-MAIL THE SALES OFFICE AT
NEWTONCOMM@ANGLIANET.CO.UK



Payment can be accepted by form of Credit or Debit card with the above logos, if you wish to send a cheque please make payable to Newton Commercial stating Card Number and expiry date. If switch, please state issue no.

HOW TO FIND US :-

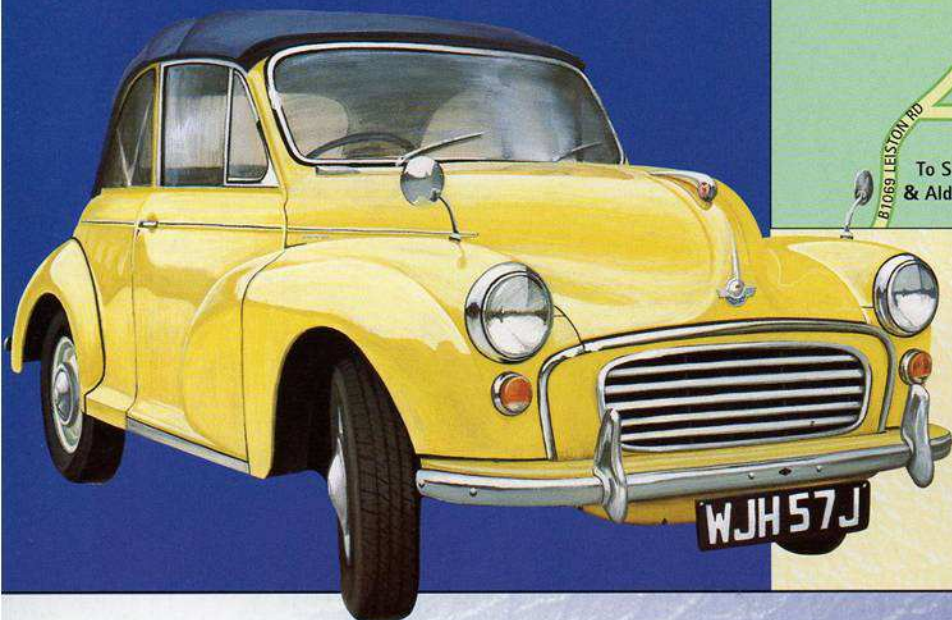
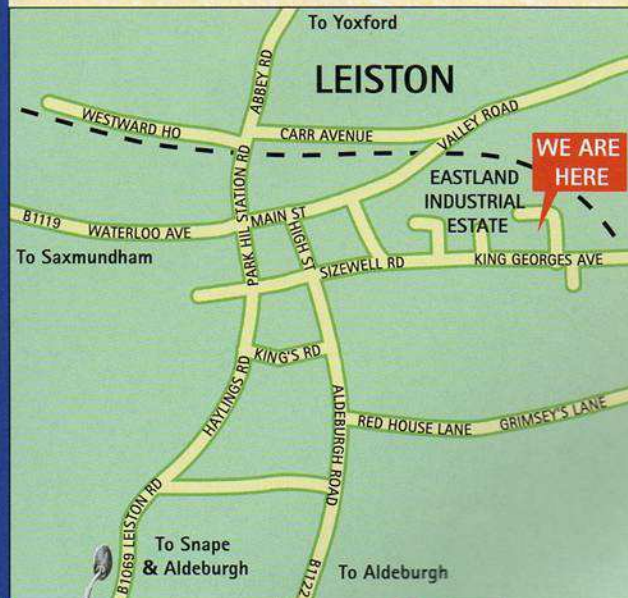

TELEPHONE NUMBER +44 (0)1728 832880

FAX NUMBER +44 (0)1728 832881

Newton Commercial was formed in 1979 by myself Richard Newton and my wife, Vera Newton to manufacture interior trim for British Classic cars. Right from the start we concentrated all our efforts on the post-war BMC range of cars. During the 1980 period we developed original specification trim for Morris Minors, Minis, Triumph Spitfire, GT6, Herald, Vitesse, the TR range as well as MGA, MGB and lately the MGF + New Mini.

Having been in the Motor trade all of my working life, I served my Apprenticeship at Morris Motors in Cowley, then spent a year at the BMC Competitions Department at Abingdon helping to prepare the Works race and rally cars. Moving then to Downton Engineering near Salisbury as Sales Manager to Bunty and Daniel Richmond, I then moved to Germany to manage the Wooding Hamburg Racing Team who ran Mini Coopers and then Ford Escort BDA's in the

European Championship. On returning to England in the mid 70's, I spent several years with Serck Services, the Radiator people, before Vera and I set up Newton Commercial from our semi detached house outside Ipswich.

Today, the Company has a large 20,000 square foot purpose built Factory in Leiston, Suffolk employing over 40 skilled craftsmen and women. All aspects of cutting, sewing, panel trimming and carpet moulding are carried out using the latest up to date technology available to our industry. The Company is an approved trim manufacturer for British Motor Heritage Ltd., whose other approved workshops and wholesalers throughout the world continually monitor the quality of our goods. The Company is also very pleased to have been awarded the "Investor In People" certificate for the third time since the inception of the scheme in the mid 1990's.



ABOUT THIS BROCHURE

We first started manufacturing interior trim for the Morris Minor in 1980 and over the following years we have developed and marketed virtually every piece that was originally fitted to these cars. Right from the start it was decided by Vera and myself that it was only possible to take on this project if we actually remanufactured these items to their original specification. Consequently, all materials have been specially commissioned to the original colours, grains and textures.

Apart from giving you graphic style drawings for every model, we have also made every effort to give you colour pictures so that you can recognize your requirements and see our quality as well.

Apart from the original specification items you will see listed, we have also recently developed certain items that we believe will enhance your Morris Minor as well. Our Suffolk reclining seats have proved very successful as they not only give increased comfort for long journeys but also look great and are a safety feature. Our latest development is our new Deluxe carpet sets, which have the tunnel sections, moulded to fit exactly. They are much easier to fit and really look the business!

We hope you enjoy our brochure and we look forward to being of service to you.



INVESTOR IN PEOPLE



BRITISH MOTOR HERITAGE APPROVED

A SNAPSHOT OF MORRIS MINOR SEAT DESIGNS FROM 1949 TO 1971

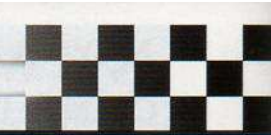

MM Series 1949-53



Series II 1953-56



Minor 1956-59



MADE IN ENGLAND



Minor 1960-62



Minor 1962-64 Duotone Style



Minor 1964-71



Our new seat covers fitted with a complete trim kit 1964-71

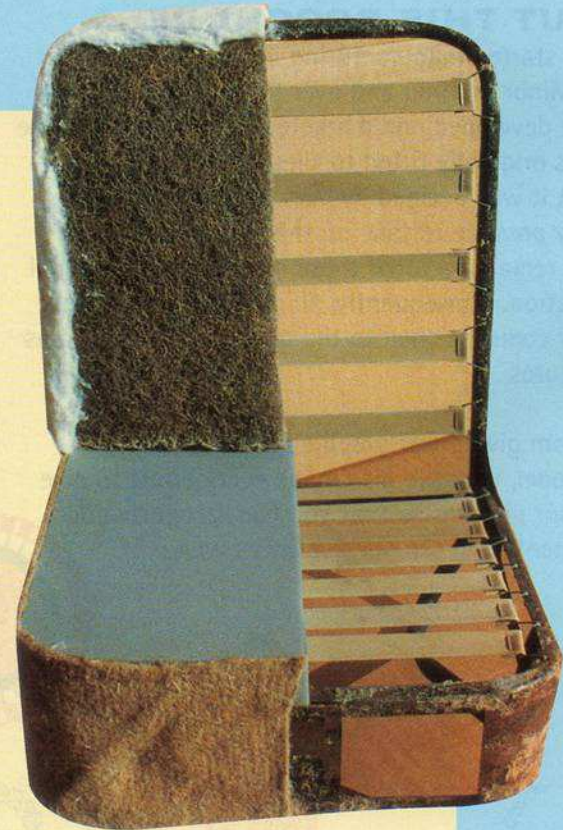

Typical seat make up of the internal items required for cars from 1956- 1971

We are utilizing new MG Rover components to make these seats in conjunction with seat covers. The seats have the latest in reclining and tilting mechanisms and twin post headrests.

The seats come with a special subframe to fit the Minor floor exactly and also seat runners which move approximately 7" front to back movement. The subframe picks up the original front bolt holes in the floor and for total rigidity, two holes need to be drilled in the floor to hold the rear of the subframe in place. M8 or M10 x 30mm long Nylock nuts & large washer for under floor.

The seats can be ordered in original Minor trim colours to match either existing trim or new trim supplied by Newton Commercial.

DESCRIPTION	PART NO
COMPLETE LH FRONT SEAT VINYL	S609
COMPLETE RH FRONT SEAT VINYL	S610
COMPLETE LH FRONT SEAT LEATHER	S613
COMPLETE RH FRONT SEAT LEATHER	S614
REAR SEAT COVERING KIT - 56-60 2DR	SC660
REAR SEAT COVERING KIT 56-60 4DR	SC661
REAR SEAT COVERING KIT - 56-60 TRAV	SC662
REAR SEAT COVERING KIT 60-62 2DR	SC663
REAR SEAT COVERING KIT 60-62 4DR	SC664
REAR SEAT COVERING KIT - 60-62 TRAV	SC665
REAR SEAT COVERING KIT 62-64 2DR	SC666
REAR SEAT COVERING KIT 62-64 4DR	SC667
REAR SEAT COVERING KIT - 62-64 - TRAV	SC668
REAR SEAT COVERING KIT - 64-71 - 2DR	SC669
REAR SEAT COVERING KIT - 64-71 - 4DR	SC670
REAR SEAT COVERING KIT 64-71 TRAV	SC671

The above numbers are for vinyl rear seat covers, for the leather equivalent please place an 'L' after the colour code.
Example: SC660HL Leather in Blue Grey

1. Subframe between seat and floor plan
2. Twin post headrest
3. Reclining wheel adjustment
4. Seat tilting handle
5. Interior showing reclining seats

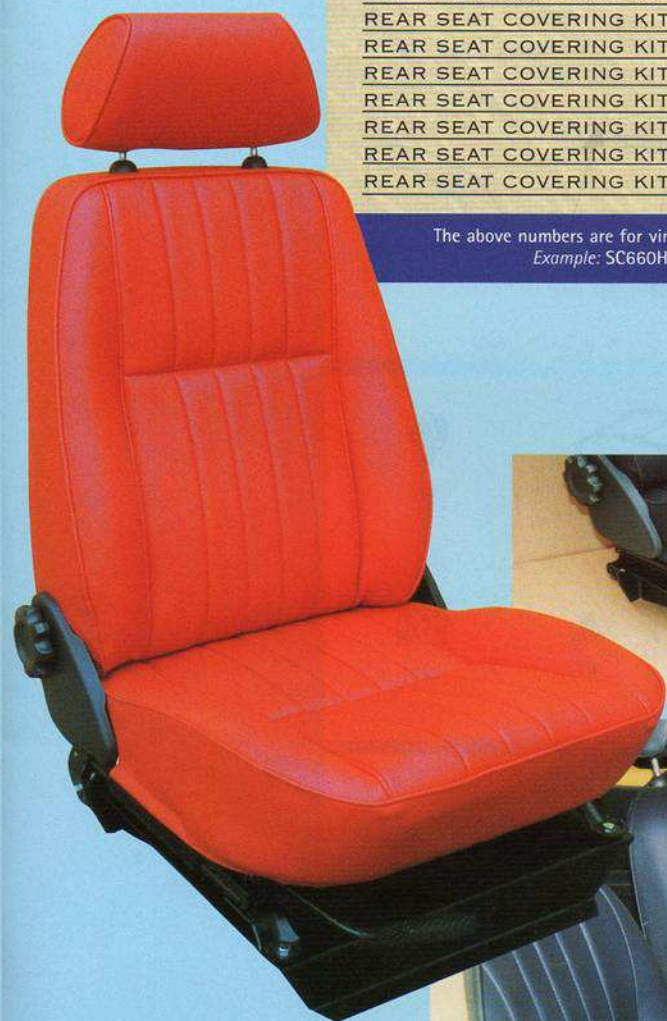

COLOURS AVAILABLE

BLACK BLUE NAVY CHEROKEE RED PORCELAIN GREEN
GREY MAROON SUEDE GREEN BISCUIT

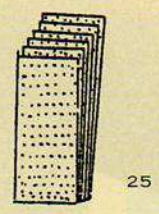
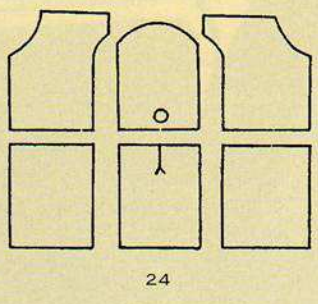
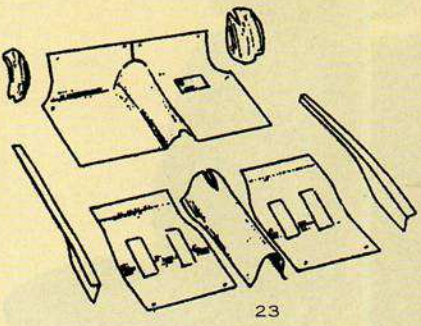
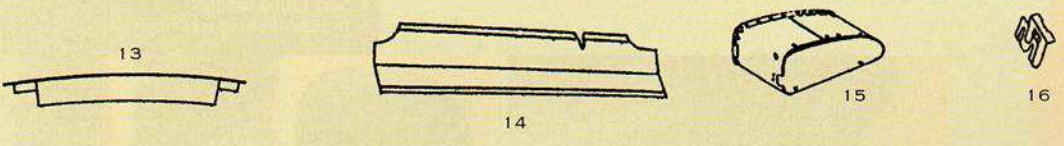
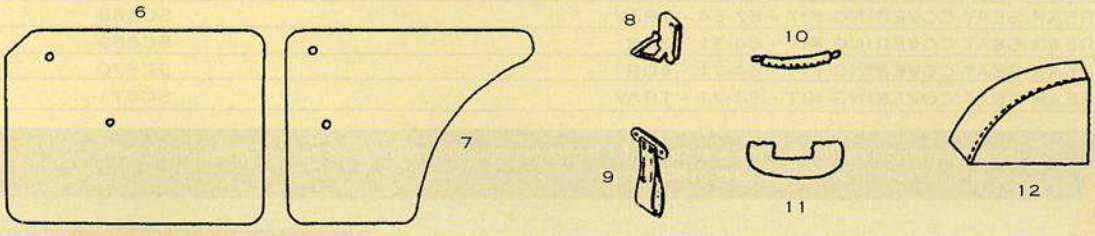
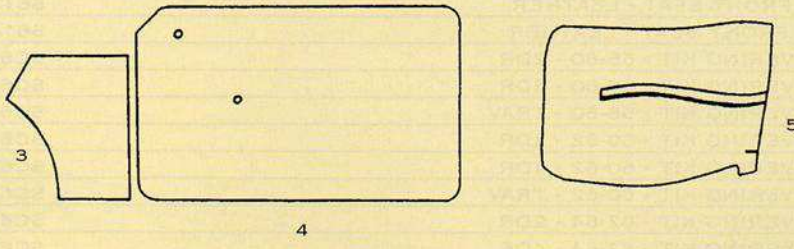
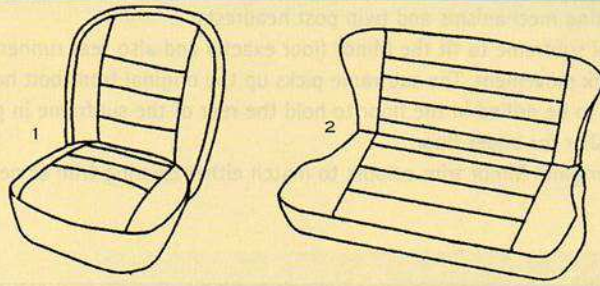

The seats on the MM models are extremely comfortable and considered by some to be the best ever designed for the Morris Minor. Originally these seats were covered in Rexine with contrasting coloured piping but after a short period of production leather seat facings were introduced. We can offer you a seat covering kit in either vinyl or leather to original specification in Maroon, Suede Green or Beige. Because of the complexity of these seats, we would strongly recommend that an experienced car trimmer fit these seat covers for you as the internal fixings and general fitting of the front seat covers is a specialised job. Most MM models had a decorative chrome strip on the door panels please retain your old units as these items are no longer available. Early cars had chain type door pulls - please send your old pulls and we will recover them for you. This also applies to the rear door pulls on 4-door models. Later cars were fitted with a more conventional type of door pull as illustrated. We do not list a headlining kit for this model, but please contact us for advice on this item. We would suggest you contact us before actually ordering parts for this model, as there are certain intricacies that need to be discussed.

No	DESCRIPTION	2 DOOR	4 DOOR	CONVERTIBLE
1	FRONT SEAT COVERING KIT BOTH SEATS LEATHER	SC601	SC601	SC601
1	FRONT SEAT COVERING KIT BOTH SEATS VINYL	SC602	SC602	SC602
2	REAR SEAT COVERING KIT LEATHER	SC603	SC604	SC603
2	REAR SEAT COVERING KIT VINYL	SC605	SC606	SC605
3	PAIR OF SCUTTLE PANELS	FL692	FL692	FL692
4	PAIR OF DOOR PANELS 2 DOOR MODELS	DP680		DP680
5	PAIR OF REAR QUARTER PANELS	WA693		WA693
6	PAIR OF DOOR PANELS 4 DOOR MODELS FRONT		DP681	
7	PAIR OF DOOR PANELS 4 DOOR MODELS - BACK		DP682	
8	PACKET OF 44 DOOR PANEL CLIPS	C702	C702	C702
9	DOOR PULL EACH VINYL	DC700	DC700	DC700
9	DOOR PULL EACH - LEATHER	DC701	DC701	DC701
10	DOOR PULL CHAIN TYPE	DC704	DC704	DC704
11	DOOR PULL - 4 DOOR REAR RECOVERING KIT		DC705	
12	PAIR OF WHEEL ARCH COVERS		WA706	
13	COCKPIT RAIL COVERING KIT			RC741
14	PARCEL SHELF RHD	PT716	PT716	PT716
14	PARCEL SHELF LHD	PT717	PT717	PT717
15	GLOVE BOX - LH	GB714	GB714	GB714
15	GLOVE BOX - RH	GB715	GB715	GB715
16	PACKET OF 8 GLOVE BOX CLIPS	GB724	GB724	GB724
17	BULKHEAD SOUND DEADENING KIT	CK751	CK751	CK751
18	DOOR DRAUGHT EXCLUDER FOR TWO DOORS	DE733	DE733	DE733
19	PACKET OF 20 DRAUGHT EXCLUDER CLIPS	DE736	DE736	DE736
20	2 DOOR WEATHERSTRIPS 2 PER WINDOW	WS737		WS737
20	4 DOOR WEATHERSTRIPS 2 PER WINDOW	FRONT = WS738	REAR = WS739	
21	WEATHERSTRIP CLIPS - 12 PER WINDOW	WS740	WS740	WS740
22	PACKET OF 20 SCREWS AND CUPWASHERS	SS100	SS100	SS100
23	CARPET SET RHD	CK742	CK742	CK742
23	CARPET SET LHD	CK743	CK743	CK743
24	CARPET UNDERFELT KIT	CK750	CK750	CK750
25	BITUMEN SOUND DEADENING PADS EACH	PT4008	PT4008	PT4008
	COMPLETE INTERIOR TRIM KIT LEATHER	TK650	TK651	TK680
	COMPLETE INTERIOR TRIM KIT VINYL	TK648	TK649	TK679

COLOURS AVAILABLE

SEAT COVERS MAROON/BEIGE SUEDE GREEN/BEIGE BEIGE/MAROON MAROON/MAROON
 PANELS MAROON BEIGE SUEDE GREEN
 CARPETS MAROON GREEN BLACK BROWN

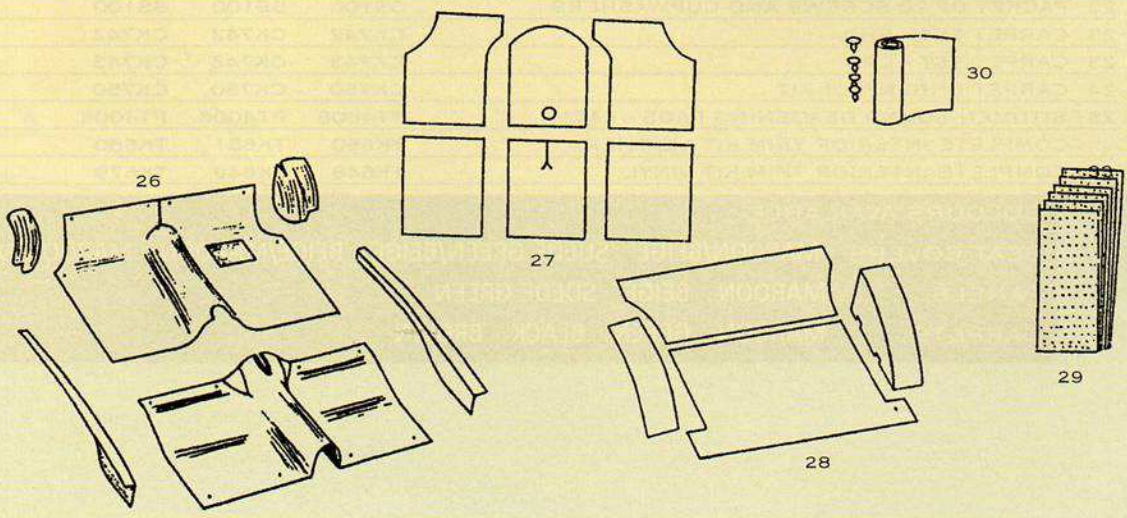
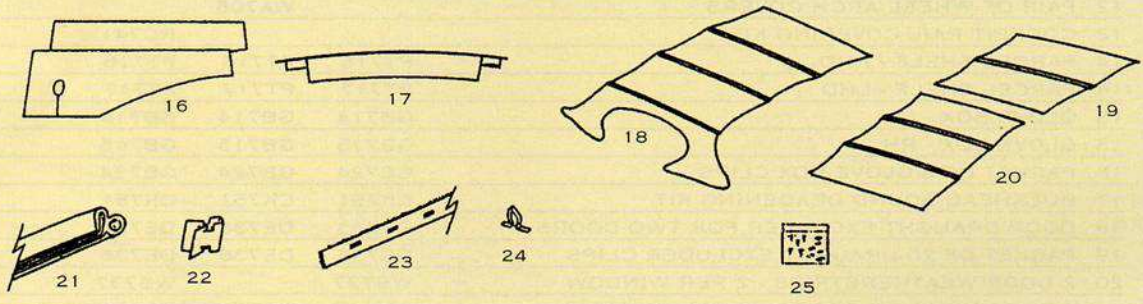
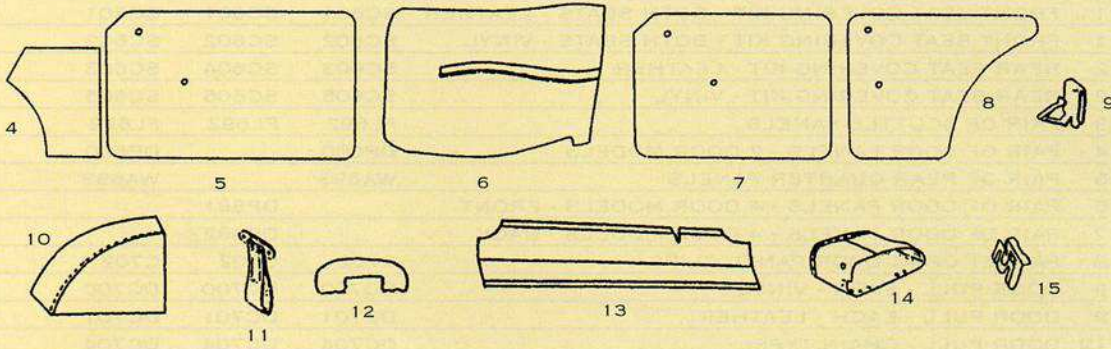
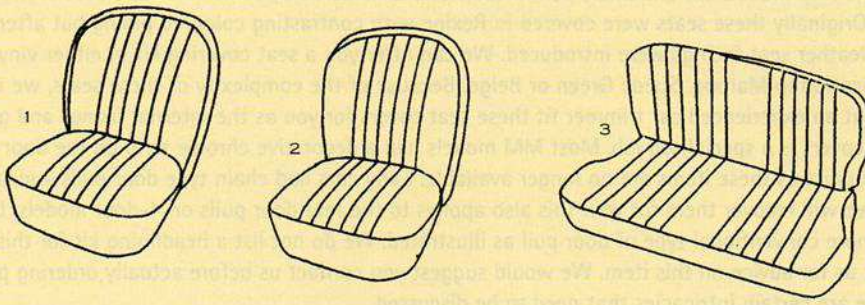

In the main the main trim panels on the Series II models were identical to those fitted to the earlier MM cars, but the seat design and construction changed slightly as can be seen here. The carpets although looking very similar were of different design as well. The Traveller series was also introduced at this time and you will see the necessary parts we manufacture for this model alongside the saloon parts. Although the front seats on all Series II vehicles look the same, early seats produced in 1953 did not have the more conventional envelope style squab cover, but a cover that was basically tacked to the seat frame and then a vinyl covered fibreboard backboard which in turn was also tacked onto the frame. The only physical way of checking to see which type of seat you have is to examine the back of the squab near the rear piping. If there is a "decorative" stitch line just below this piping on the back panel then this is the early type seat. The base covers are the same for both types. You will note that we have listed headlining kits. These are not for early cars with the plywood type headlining but for later cars with conventional hooped linings. Although we mention the rear 4 door armrest recovering kit, we would suggest you send your old units to us for recovering, as this can be quite tricky.

No	DESCRIPTION	2 DOOR	4 DOOR	CONVERTIBLE	TRAVELLER
1	FRONT SEAT COVERING KIT EARLY LEATHER	SC607	SC607	SC607	SC607
1	FRONT SEAT COVERING KIT EARLY VINYL	SC608	SC608	SC608	SC608
1	FRONT SEAT COVERING KIT LATE LEATHER	SC609	SC609	SC609	SC609
1	FRONT SEAT COVERING KIT LATE - VINYL	SC609/2	SC609/2	SC609/2	SC609/2
2	REAR SEAT COVERING KIT - LEATHER	SC610	SC612	SC610	SC614
2	REAR SEAT COVERING KIT VINYL	SC611	SC613	SC611	SC615
4	PAIR OF SCUTTLE PANELS	FL692	FL692	FL692	FL692
5	PAIR OF DOOR PANELS 2 DOOR MODELS	DP680		DP680	DP680
6	PAIR OF REAR QUARTER PANELS	WA693		WA693	WA694
7	PAIR OF DOOR PANELS 4 DOOR MODELS FRONT		DP681		
8	PAIR OF DOOR PANELS - 4 DOOR MODELS BACK		DP682		
9	PACKET OF 44 DOOR PANEL CLIPS	C702	C702	C702	C702
10	PAIR OF WHEEL ARCH COVERS		WA706		
11	DOOR PULL EACH - LEATHER	DC701	DC701	DC701	DC701
11	DOOR PULL - EACH VINYL	DC700	DC700	DC700	DC700
12	DOOR PULL - 4 DOOR REAR RECOVERING KIT		DC705		
13	PARCEL SHELF RHD	PT716	PT716	PT716	PT716
13	PARCEL SHELF LHD	PT717	PT717	PT717	PT717
14	GLOVE BOX LH	GB710	GB710	GB710	GB710
14	GLOVE BOX RH	GB711	GB711	GB711	GB711
15	PACKET OF 8 GLOVE BOX CLIPS	GB724	GB724	GB724	GB724
16	PAIR OF REAR COMPARTMENT PANELS				CP699
17	COCKPIT RAIL COVERING KIT			RC741	
18	HEADLINING KIT LARGE REAR WINDOW 4 HOOPS	HL724	HL724		
18	HEADLINING KIT SMALL REAR WINDOW - 4 HOOPS	HL725	HL725		
19	FRONT HEADLINING				HL727
20	REAR HEADLINING				HL728
21	DOOR DRAUGHT EXCLUDER FOR TWO DOORS	DE733	DE733	DE733	DE733
22	PACKET OF 20 DRAUGHT EXCLUDER CLIPS	DE736	DE736	DE736	DE736
23	2 DOOR WEATHERSTRIPS 2 PER WINDOW	WS737		WS737	WS737
23	4 DOOR WEATHERSTRIPS - 2 PER WINDOW	FRONT = WS738 REAR = WS739			
24	WEATHERSTRIP CLIPS 12 PER WINDOW	WS740	WS740	WS740	WS740
25	PACKET OF 20 SCREWS AND CUPWASHERS	SS100	SS100	SS100	SS100
26	CARPET SET RHD	CK744	CK744	CK744	CK744
26	CARPET SET LHD	CK745	CK745	CK745	CK745
27	CARPET UNDERFELT KIT	CK750	CK750	CK750	CK750
28	REAR COMPARTMENT MAT SET - GREY HARDURA				CK749
29	BULKHEAD SOUND DEADENING KIT	CK751	CK751	CK751	CK751
30	BITUMEN SOUND DEADENING PADS EACH	PT4008	PT4008	PT4008	PT4008
	COMPLETE INTERIOR TRIM KIT LEATHER	TK654	TK655	TK682	TK657
	COMPLETE INTERIOR TRIM KIT VINYL	TK652	TK653	TK681	TK656

COLOURS AVAILABLE
MAROON SUEDE GREEN DOVE GREY

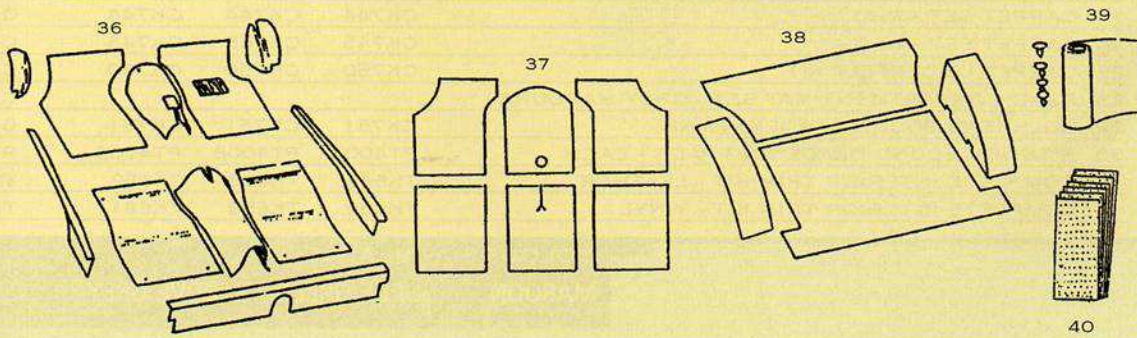
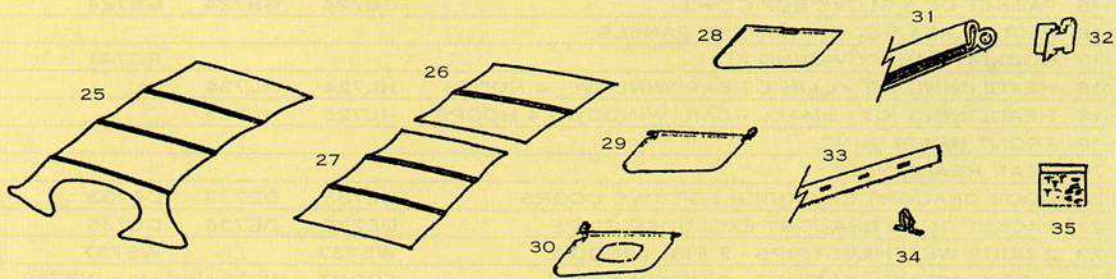
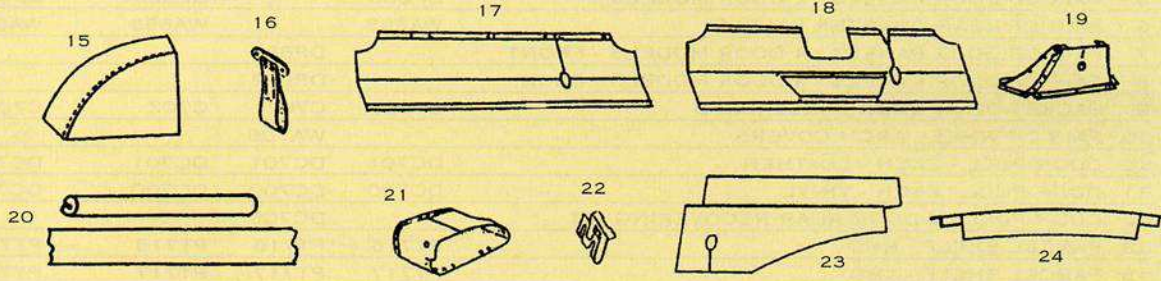
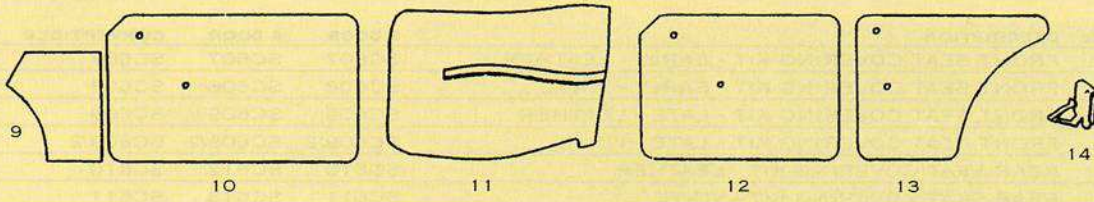
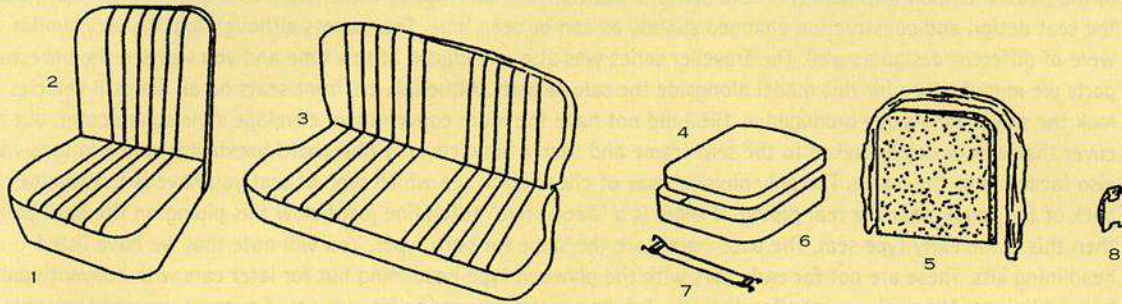

With the introduction of the Minor 1000 in late 1956 a completely new front seat frame was used with "modern" internal foams and seat straps. Originally "Deluxe" cars usually had leather faced seat covers, whereas "standard" cars had vinyl seat covers. It is possible, however, to find cars fitted with leather front and vinyl rear seats. Contrasting light grey coloured pipings were also used in this period, although we have come across many cars fitted with self-coloured pipings. Most front seats during this period were "fixed" but in 1959 it is possible to find passenger seats that "fold" down. This allowed better access on 2 door models to the rear seats. Other changes on this range included a new larger parcel tray usually with a heater duct fitted, which actually enclosed the round heater unit but it is possible that certain cars had just a parcel tray. A foamed crash pad was also added to the front of the parcel tray. We are offering two types of headlining material for all models, one being a creamy beige with a light brown fleck and the other a very light grey with matching sunvisors. Please note from the illustration there are two types available, one with a central fixing bracket and the other which is a large pad and has brackets fitted at either end.

No	DESCRIPTION	2 DOOR	4 DOOR	CONVERTIBLE	TRAVELLER
1	FRONT SEAT BASE COVER LEATHER	SC622	SC622	SC622	SC622
1	FRONT SEAT BASE COVER VINYL	SC616	SC616	SC616	SC616
2	FRONT SEAT SQUAB COVER LEATHER FIXED	SC623	SC623	SC623	SC623
2	FRONT SEAT SQUAB COVER VINYL FIXED	SC617	SC617	SC617	SC617
3	REAR SEAT COVERING KIT LEATHER	SC625	SC626	SC625	SC627
3	REAR SEAT COVERING KIT VINYL	SC619	SC620	SC619	SC621
4	FRONT SEAT BASE FOAM CUSHION	SF655	SF655	SF655	SF655
5	FRONT SEAT SQUAB PADDING	SF666	SF666	SF666	SF666
6	FRONT SEAT BASE FRAME FOAM WRAP	SF660	SF660	SF660	SF660
7	PIRELLI SEAT STRAPS	ST654	ST654	ST654	ST654
8	PACKET OF 20 FRONT SEAT CLIPS	C707	C707	C707	C707
9	PAIR OF SCUTTLE PANELS	FL692	FL692	FL692	FL692
10	PAIR OF DOOR PANELS - 2 DOOR MODELS	DP680		DP680	DP680
11	PAIR OF REAR QUARTER PANELS	WA693		WA693	WA694
12	PAIR OF DOOR PANELS 4 DOOR MODELS FRONT		DP681		
13	PAIR OF DOOR PANELS 4 DOOR MODELS BACK		DP682		
14	PACKET OF 44 DOOR PANEL CLIPS	C702	C702	C702	C702
15	PAIR OF WHEEL ARCH COVERS		WA706		
16	DOOR PULL EACH LEATHER	DC701	DC701	DC701	DC701
16	DOOR PULL EACH VINYL	DC700	DC700	DC700	DC700
17	PARCEL SHELF RHD	PT721	PT721	PT721	PT721
17	PARCEL SHELF LHD	PT722	PT722	PT722	PT722
18	PARCEL SHELF RHD TO ACCEPT DUCT	PT718	PT718	PT718	PT718
18	PARCEL SHELF LHD TO ACCEPT DUCT	PT719	PT719	PT719	PT719
19	PARCEL TRAY HEATER DUCT	PT720	PT720	PT720	PT720
20	CRASH PAD KIT	PT723	PT723	PT723	PT723
21	GLOVE BOX LH	GB710	GB710	GB710	GB710
21	GLOVE BOX RH	GB711	GB711	GB711	GB711
22	PACKET OF 8 GLOVE BOX CLIPS	GB724	GB724	GB724	GB724
23	PAIR OF REAR COMPARTMENT PANELS				CP699
24	COCKPIT RAIL COVERING KIT			RC741	
25	HEADLINING KIT SMALL REAR WINDOW 4 HOOPS	HL725	HL725	(EARLY MODELS)	
25	HEADLINING KIT LARGE REAR WINDOW 3 HOOPS	HL726	HL726	(LATER MODELS)	
26	FRONT HEADLINING				HL727
27	REAR HEADLINING				HL728
28	EARLY TYPE SUNVISOR CENTRAL BRACKET	SV2000	SV2000	SV2000	SV2000
29	LATER TYPE SUNVISOR OUTER BRACKETS	SV732	SV732	SV732	SV732
30	LATER TYPE SUNVISOR OUTER BRACKETS MIRROR	SV733	SV733	SV733	SV733
31	DOOR DRAUGHT EXCLUDER FOR TWO DOORS	DE733	DE733	DE733	DE733
32	PACKET OF 20 DRAUGHT EXCLUDER CLIPS	DE736	DE736	DE736	DE736
33	2 DOOR WEATHERSTRIPS 2 PER WINDOW	WS737		WS737	WS737
33	4 DOOR WEATHERSTRIPS 2 PER WINDOW	FRONT = WS738	REAR = WS739		
34	WEATHERSTRIP CLIPS 12 PER WINDOW	WS740	WS740	WS740	WS740
35	PACKET OF 20 SCREWS AND CUPWASHERS	SS100	SS100	SS100	SS100
36	CARPET-SET RHD	CK746	CK746	CK746	CK746
36	CARPET SET LHD	CK747	CK747	CK747	CK747
37	CARPET UNDERFELT KIT	CK750	CK750	CK750	CK750
38	REAR COMPARTMENT MAT SET GREY HARDURA				CK749
39	BULKHEAD SOUND DEADENING KIT	CK751	CK751	CK751	CK751
40	BITUMEN SOUND DEADENING PADS EACH	PT4008	PT4008	PT4008	PT4008
	COMPLETE INTERIOR TRIM KIT LEATHER	TK661	TK662	TK684	TK663
	COMPLETE INTERIOR TRIM KIT VINYL	TK658	TK659	TK683	TK660

COLOURS AVAILABLE
 MAROON SUED GREEN

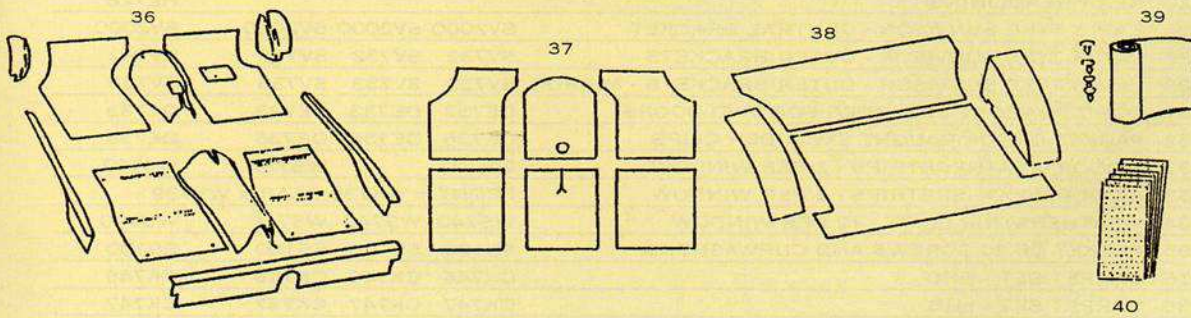
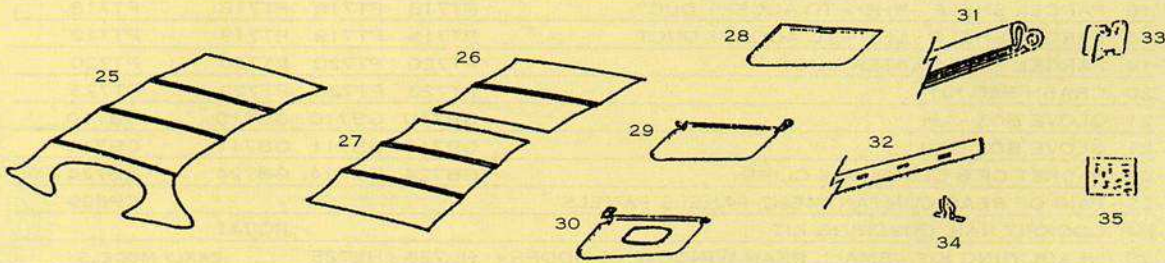
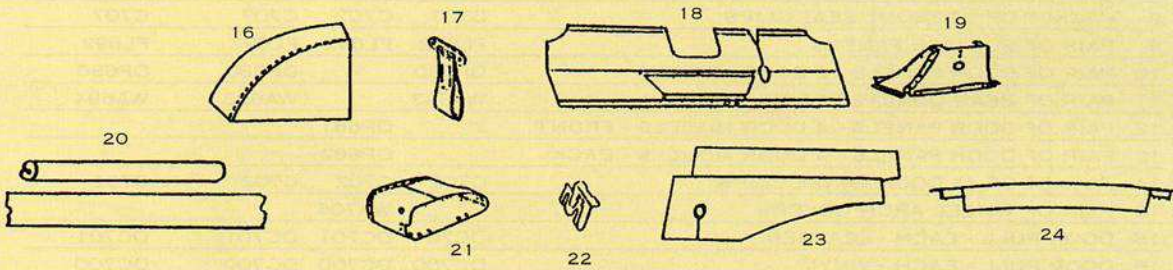
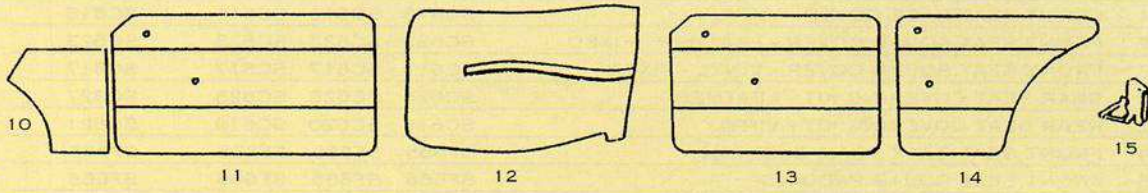
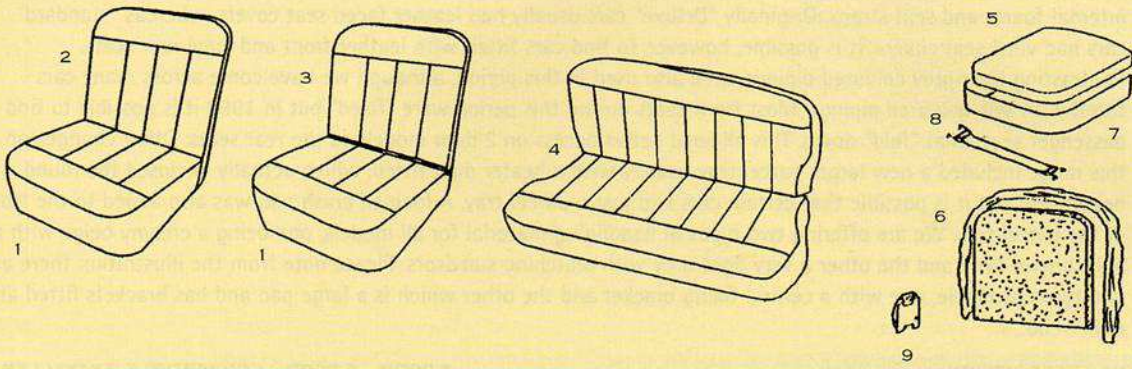

In the autumn of 1959 the seat design was changed again to incorporate larger fluted facing panels on both the front and rear seats. The passenger seat was of the "folding" type again on 2 door models and both leather and vinyl seats were offered. The design on the door panels was also altered to give them more character. The specification of this model was the same as the 56-59 cars.

No	DESCRIPTION	2 DOOR	4 DOOR	CONVERTIBLE	TRAVELLER
1	FRONT SEAT BASE COVER LEATHER	SC634	SC634	SC634	SC634
1	FRONT SEAT BASE COVER VINYL	SC628	SC628	SC628	SC628
2	FRONT SEAT SQUAB COVER LEATHER FIXED	SC635	SC635	SC635	SC635
2	FRONT SEAT SQUAB COVER VINYL FIXED	SC629	SC629	SC629	SC629
3	FRONT SEAT SQUAB COVER LEATHER FOLDING	SC636	SC636	SC636	SC636
3	FRONT SEAT SQUAB COVER VINYL FOLDING	SC630	SC630	SC630	SC630
4	REAR SEAT COVERING KIT LEATHER	SC637	SC638	SC637	SC639
4	REAR SEAT COVERING KIT VINYL	SC631	SC632	SC631	SC633
5	FRONT SEAT BASE FOAM CUSHION	SF655	SF655	SF655	SF655
6	FRONT SEAT SQUAB PADDING	SF666	SF666	SF666	SF666
7	FRONT SEAT BASE FRAME FOAM WRAP	SF660	SF660	SF660	SF660
8	PIRELLI SEAT STRAPS	ST654	ST654	ST654	ST654
9	PACKET OF 20 FRONT SEAT CLIPS	C707	C707	C707	C707
10	PAIR OF SCUTTLE PANELS	FL692	FL692	FL692	FL692
11	PAIR OF DOOR PANELS - 2 DOOR MODELS	DP683		DP683	DP683
12	PAIR OF REAR QUARTER PANELS	WA693		WA693	WA694
13	PAIR OF DOOR PANELS 4 DOOR MODELS FRONT		DP684		
14	PAIR OF DOOR PANELS 4 DOOR MODELS BACK		DP685		
15	PACKET OF 44 DOOR PANEL CLIPS	C702	C702	C702	C702
16	PAIR OF WHEEL ARCH COVERS		WA706		
17	DOOR PULL - EACH LEATHER	DC701	DC701	DC701	DC701
17	DOOR PULL EACH VINYL	DC700	DC700	DC700	DC700
18	PARCEL SHELF RHD	PT718	PT718	PT718	PT718
18	PARCEL SHELF LHD	PT719	PT719	PT719	PT719
19	PARCEL TRAY HEATER DUCT	PT720	PT720	PT720	PT720
20	PARCEL TRAY CRASH PAD BLACK ONLY	PT723	PT723	PT723	PT723
21	GLOVE BOX LH	GB710	GB710	GB710	GB710
21	GLOVE BOX RH	GB711	GB711	GB711	GB711
22	PACKET OF 8 GLOVE BOX CLIPS	GB724	GB724	GB724	GB724
23	PAIR OF REAR COMPARTMENT PANELS				CP699
24	COCKPIT RAIL COVERING KIT			RC741	
25	HEADLINING KIT	HL726	HL726		
26	FRONT HEADLINING				HL727
27	REAR HEADLINING				HL728
28	EARLY TYPE SUNVISOR CENTRAL BRACKET	SV2000	SV2000	SV2000	SV2000
29	LATER TYPE SUNVISOR OUTER BRACKETS	SV732	SV732	SV732	SV732
30	LATER TYPE SUNVISOR OUTER BRACKETS MIRROR	SV733	SV733	SV733	SV733
31	DOOR DRAUGHT EXCLUDER FOR TWO DOORS	DE733	DE733	DE733	DE733
32	PACKET OF 20 DRAUGHT EXCLUDER CLIPS	DE736	DE736	DE736	DE736
33	2 DOOR WEATHERSTRIPS 2 PER WINDOW	WS737		WS737	WS737
33	4 DOOR WEATHERSTRIPS 2 PER WINDOW	FRONT = WS738	REAR = WS739		
34	WEATHERSTRIP CLIPS 12 PER WINDOW	WS740	WS740	WS740	WS740
35	PACKET OF 20 SCREWS AND CUPWASHERS	SS100	SS100	SS100	SS100
36	CARPET SET RHD	CK746	CK746	CK746	CK746
36	CARPET SET - LHD	CK747	CK747	CK747	CK747
37	CARPET UNDERFELT KIT	CK750	CK750	CK750	CK750
38	REAR COMPARTMENT MAT SET GREY HARDURA				CK749
39	BULKHEAD SOUND DEADENING KIT	CK751	CK751	CK751	CK751
40	BITUMEN SOUND DEADENING PADS EACH	PT4008	PT4008	PT4008	PT4008
	COMPLETE INTERIOR TRIM KIT LEATHER	TK667	TK668	TK686	TK666
	COMPLETE INTERIOR TRIM KIT - VINYL	TK664	TK665	TK685	TK669

COLOURS AVAILABLE

MAROON

LIGHT BLUE

BISCUIT

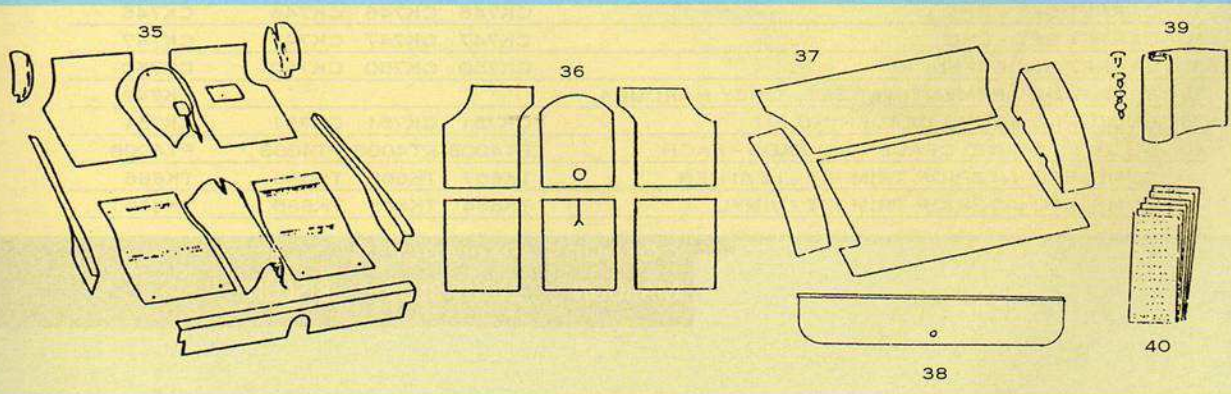
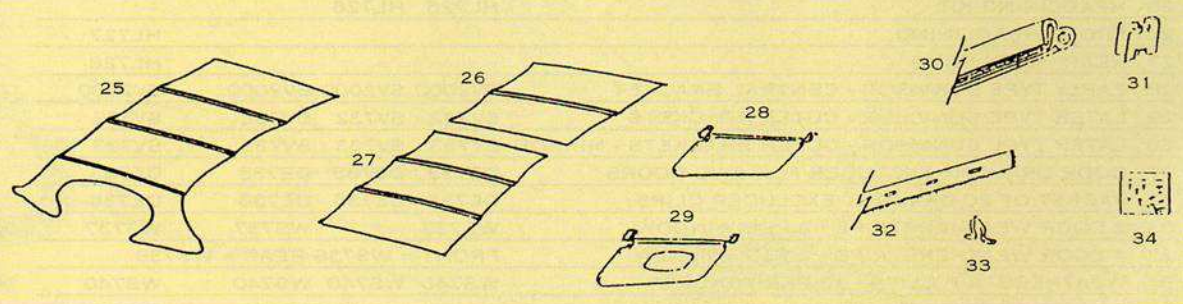
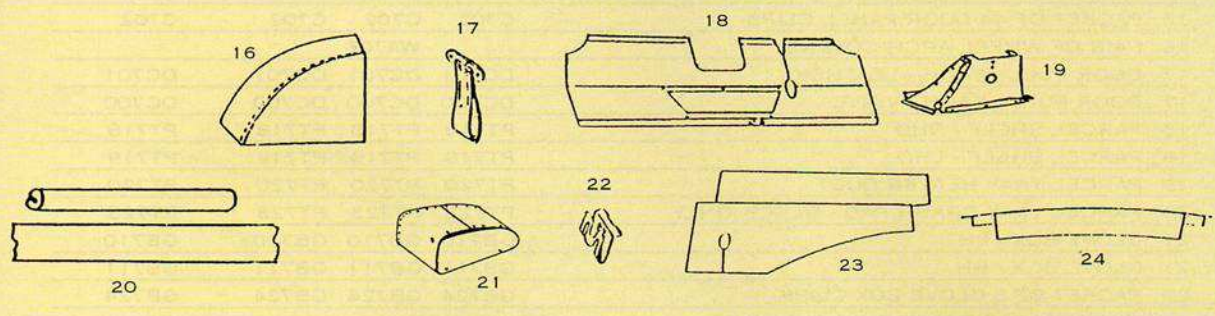
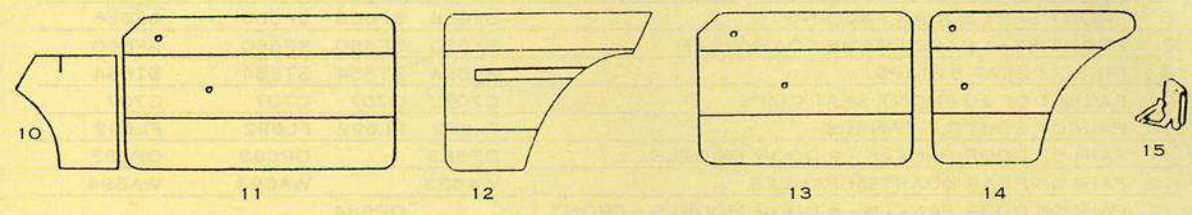
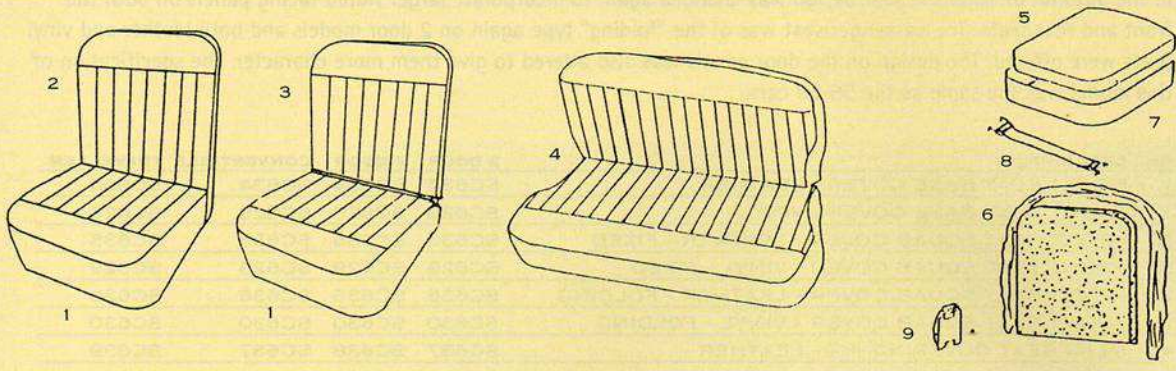

For the October 1961 Motor Show in London, BMC introduced a much face lifted Minor range and amongst many modifications to the body, the interior design was completely changed. The 1960's new pastel colour scheme was introduced which stayed in production until the Minor was finally withdrawn in the early 1970's. Cherokee Red, Blue Grey and Porcelain Green were the new colours with the addition of Beige "Duotone" contrasting material used on the seats and trim panels. This design was used on all deluxe models, but standard models did not have the "Duotone" inserts. The dash board was also altered, consequently the shape of the glove boxes was different to previous models as well as having a chromed finishing strip right round the leading edge. At this time the Travellers were supplied with black painted fibreboard panels under the rear load area to hide the spare wheel situated underneath.

No	DESCRIPTION	2 DOOR	4 DOOR	CONVERTIBLE	TRAVELLER
1	FRONT SEAT BASE COVER VINYL	SC640	SC640	SC640	SC640
2	FRONT SEAT SQUAB COVER VINYL FIXED	SC641	SC641	SC641	SC641
3	FRONT SEAT SQUAB COVER VINYL FOLDING	SC642	SC642	SC642	SC642
4	REAR SEAT COVERING KIT VINYL	SC643	SC644	SC643	SC645
5	FRONT SEAT BASE FOAM CUSHION	SF655	SF655	SF655	SF655
6	FRONT SEAT SQUAB PADDING	SF666	SF666	SF666	SF666
7	FRONT SEAT BASE FRAME FOAM WRAP	SF660	SF660	SF660	SF660
8	PIRELLI SEAT STRAPS	ST654	ST654	ST654	ST654
9	PACKET OF 20 FRONT SEAT CLIPS	C707	C707	C707	C707
10	PAIR OF SCUTTLE PANELS	FL692	FL692	FL692	FL692
11	PAIR OF DOOR PANELS 2 DOOR MODELS	DP686		DP686	DP686
12	PAIR OF REAR QUARTER PANELS	WA695		WA695	WA696
13	PAIR OF DOOR PANELS 4 DOOR MODELS FRONT		DP687		
14	PAIR OF DOOR PANELS 4 DOOR MODELS BACK		DP688		
15	PACKET OF 44 DOOR PANEL CLIPS	C702	C702	C702	C702
16	PAIR OF WHEEL ARCH COVERS	WA706	WA706	WA706	WA707
17	DOOR PULL - EACH LEATHER	DC701	DC701	DC701	DC701
17	DOOR PULL - EACH VINYL	DC700	DC700	DC700	DC700
18	PARCEL SHELF RHD	PT718	PT718	PT718	PT718
18	PARCEL SHELF LHD	PT719	PT719	PT719	PT719
19	PARCEL TRAY HEATER DUCT	PT720	PT720	PT720	PT720
20	PARCEL TRAY CRASH PAD BLACK ONLY	PT723	PT723	PT723	PT723
21	GLOVE BOX LH	GB712	GB712	GB712	GB712
21	GLOVE BOX RH	GB713	GB713	GB713	GB713
22	PACKET OF 8 GLOVE BOX CLIPS	GB724	GB724	GB724	GB724
23	PAIR OF REAR COMPARTMENT PANELS				CP699
24	COCKPIT RAIL COVERING KIT			RC741	
25	HEADLINING KIT	HL726	HL726		
26	FRONT HEADLINING				HL727
27	REAR HEADLINING				HL728
28	LATER TYPE SUNVISOR OUTER BRACKETS	SV732	SV732	SV732	SV732
29	LATER TYPE SUNVISOR OUTER BRACKETS MIRROR	SV733	SV733	SV733	SV733
30	DOOR DRAUGHT EXCLUDER FOR TWO DOORS	DE733	DE733	DE733	DE733
31	PACKET OF 20 DRAUGHT EXCLUDER CLIPS	DE736	DE736	DE736	DE736
32	2 DOOR WEATHERSTRIPS - 2 PER WINDOW	WS737		WS737	WS737
32	4 DOOR WEATHERSTRIPS 2 PER WINDOW	FRONT = WS738	REAR = WS739		
33	WEATHERSTRIP CLIPS - 12 PER WINDOW	WS740	WS740	WS740	WS740
34	PACKET OF 20 SCREWS AND CUPWASHERS	SS100	SS100	SS100	SS100
35	CARPET SET RHD	CK746	CK746	CK746	CK746
35	CARPET SET - LHD	CK747	CK747	CK747	CK747
36	CARPET UNDERFELT KIT	CK750	CK750	CK750	CK750
37	REAR COMPARTMENT MAT SET GREY HARDURA				CK749
38	SPARE WHEEL APERTURE BOARD				TP140
39	BULKHEAD SOUND DEADENING PADS KIT	CK751	CK751	CK751	CK751
40	BITUMEN SOUND DEADENING PADS EACH	PT4008	PT4008	PT4008	PT4008
	COMPLETE INTERIOR TRIM KIT VINYL ONLY	TK670	TK671	TK687	TK672

COLOURS AVAILABLE

PORCELAIN GREEN

CHEROKEE RED

BLUE GREY

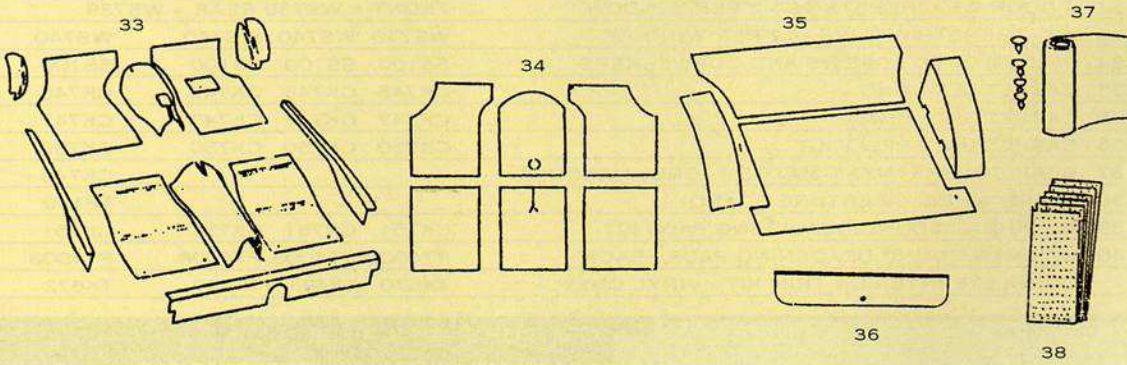
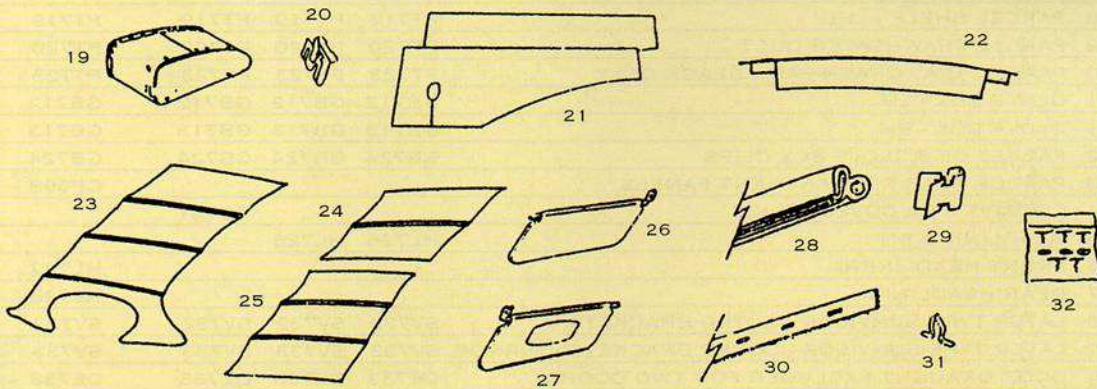
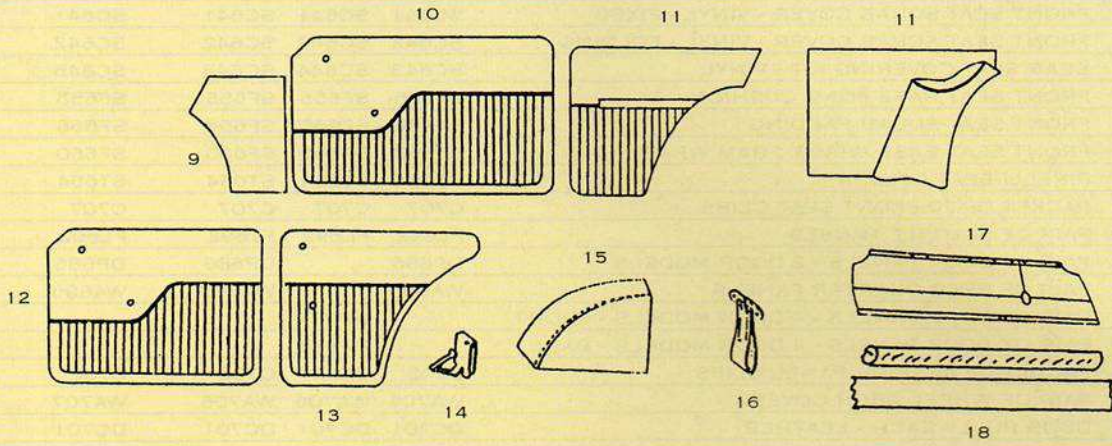
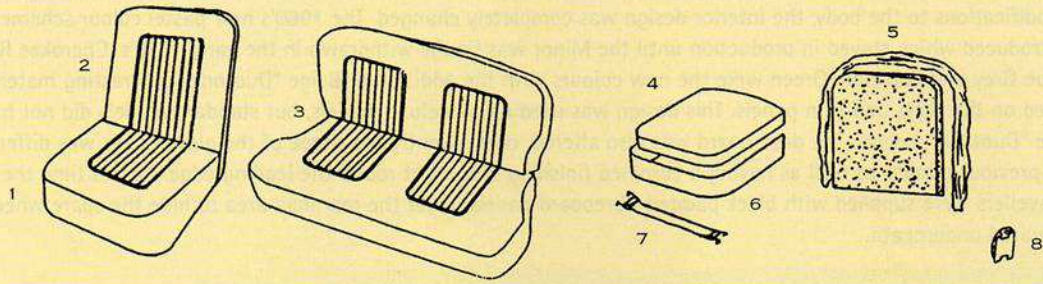

The final interior trim design came in late 1963 with the introduction of heat formed designs on all seat covers, door and saloon rear quarter panels. The design is created by a High Frequency electrical welding technique that we carry out on our own machines. Initially Cherokee Red, Blue Grey and Porcelain Green were offered but later models have Black, Navy, Autumn Leaf and Lime flower. All these colours are available with the exception of Lime flower, which because of very low numbers originally manufactured does not warrant us having new material made. As a matter of interest most cars sold to the Military Forces and Social Services were fitted out in Autumn Leaf and all police cars had Black interiors usually with zips in their headlinings for the Blue lamp! If you are interested in having leather seats instead of the standard vinyl type we cannot offer you the same design but suggest you consider the design used on the 60-62 models. This combination has proved very popular over the years. Apart from the items mentioned above very little else has changed except for the glove boxes that were altered to fit the modified dashboard.

No	DESCRIPTION	2 DOOR	4 DOOR	CONVERTIBLE	TRAVELLER
1	FRONT SEAT BASE COVER VINYL	SC646	SC646	SC646	SC646
2	FRONT SEAT SQUAB COVER VINYL	SC647	SC647	SC647	SC647
3	REAR SEAT COVERING KIT VINYL	SC650	SC651	SC650	SC652
4	FRONT SEAT BASE FOAM CUSHION	SF655	SF655	SF655	SF655
5	FRONT SEAT SQUAB PADDING	SF666	SF666	SF666	SF666
6	FRONT SEAT BASE FRAME FOAM WRAP	SF660	SF660	SF660	SF660
7	PIRELLI SEAT STRAPS	ST654	ST654	ST654	ST654
8	PACKET OF FRONT 20 SEAT CLIPS	C707	C707	C707	C707
9	PAIR OF SCUTTLE PANELS	FL692	FL692	FL692	FL692
10	PAIR OF DOOR PANELS 2 DOOR MODELS	DP689		DP689	DP689
11	PAIR OF REAR QUARTER PANELS	WA697		WA697	WA698
12	PAIR OF DOOR PANELS 4 DOOR MODELS FRONT		DP690		
13	PAIR OF DOOR PANELS - 4 DOOR MODELS BACK		DP691		
14	PACKET OF 44 DOOR PANEL CLIPS	C702	C702	C702	C702
15	PAIR OF WHEEL ARCH COVERS	WA706	WA706	WA706	
16	DOOR PULL - EACH LEATHER	DC701	DC701	DC701	DC701
16	DOOR PULL EACH VINYL	DC700	DC700	DC700	DC700
17	PARCEL SHELF RHD	PT721	PT721	PT721	PT721
17	PARCEL SHELF LHD	PT722	PT722	PT722	PT722
18	PARCEL TRAY CRASH PAD BLACK ONLY	PT723	PT723	PT723	PT723
19	GLOVE BOX LH	GB714	GB714	GB714	GB714
19	GLOVE BOX RH	GB715	GB715	GB715	GB715
20	PACKET OF 8 GLOVE BOX CLIPS	GB724	GB724	GB724	GB724
21	PAIR OF REAR COMPARTMENT PANELS				CP699
22	COCKPIT RAIL COVERING KIT			RC741	
23	HEADLINING KIT	HL726	HL726		
24	FRONT HEADLINING				HL727
25	REAR HEADLINING				HL728
26	LATER TYPE SUNVISOR - OUTER BRACKETS	SV732	SV732	SV732	SV732
27	LATER TYPE SUNVISOR OUTER BRACKETS MIRROR	SV733	SV733	SV733	SV733
28	DOOR DRAUGHT EXCLUDER FOR TWO DOORS	DE733	DE733	DE733	DE733
29	PACKET OF 20 DRAUGHT EXCLUDER CLIPS	DE736	DE736	DE736	DE736
30	2 DOOR WEATHERSTRIPS 2 PER WINDOW	WS737		WS737	WS737
30	4 DOOR WEATHERSTRIPS 2 PER WINDOW	FRONT = WS738	REAR = WS739		
31	WEATHERSTRIP CLIPS - 12 PER WINDOW	WS740	WS740	WS740	WS740
32	PACKET OF 20 SCREWS AND CUPWASHERS	SS100	SS100	SS100	SS100
33	CARPET SET RHD	CK746	CK746	CK746	CK746
33	CARPET SET - LHD	CK747	CK747	CK747	CK747
34	CARPET UNDERFELT KIT	CK750	CK750	CK750	CK750
35	REAR COMPARTMENT MAT SET GREY HARDURA				CK749
36	SPARE WHEEL APERTURE BOARD				TP140
37	BULKHEAD SOUND DEADENING KIT	CK751	CK751	CK751	CK751
38	BITUMEN SOUND DEADENING PADS EACH	PT4008	PT4008	PT4008	PT4008
	COMPLETE INTERIOR TRIM KIT VINYL	TK673	TK674	TK688	TK675

COLOURS AVAILABLE

PORCELAIN GREEN CHEROKEE RED BLUE GREY
BLACK AUTUMN LEAF

MINOR VAN & PICK UP

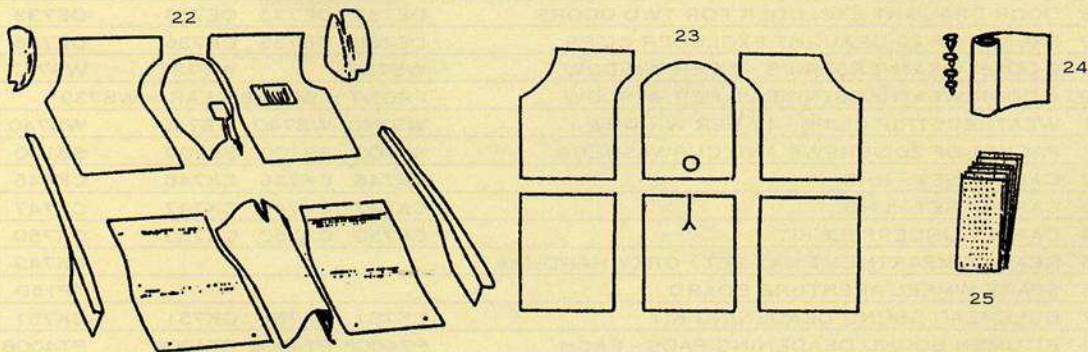
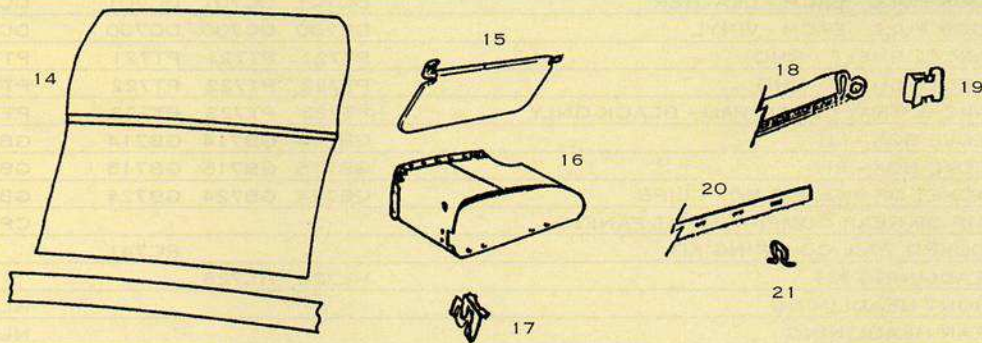
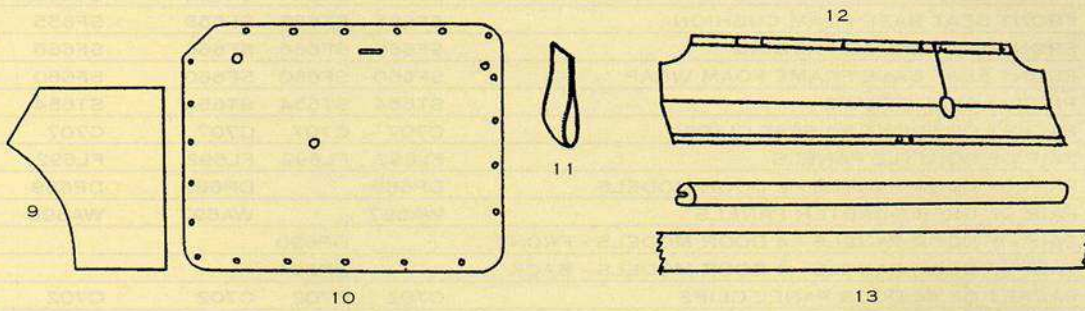
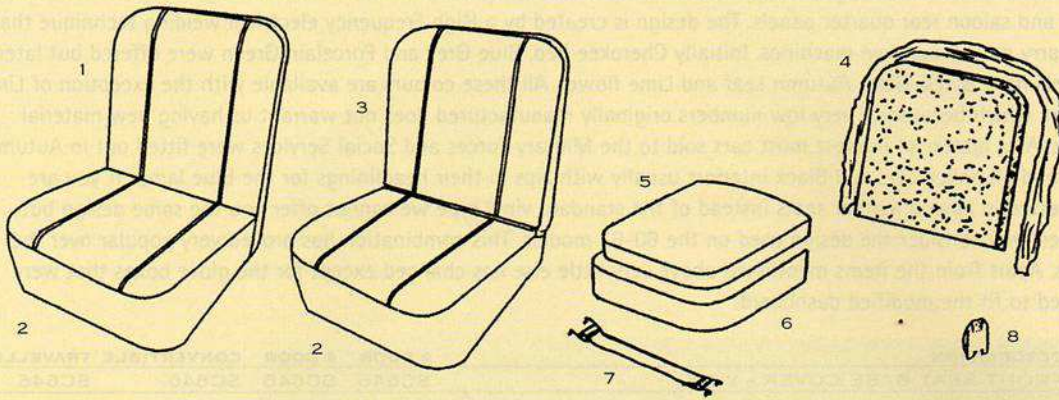

Vans and Pickups were obviously the workhorses of the Minor range and in their day were used not only by the Butcher, Baker and Candlestick maker but also by Farmers and huge organisations like the Post Office and the Armed Forces. Consequently the interior trim was functional and fairly basic and usually only came in two colours namely black and brown. We can only offer trim for these cars in black, as the demand for the brown is too low for us to warrant the expenditure on having new material manufactured. There were various seat designs over the years, but the most popular today is the later style that has two simulated stitch weld designs on the seat cover faces as illustrated. It is usual to find that the passenger seat is of the folding type but it is possible to have two fixed seats so please check the seats carefully before ordering. The door panels are as original, being painted black hardboard and come with necessary fitting clips. One interesting feature on these models is that the very early style glove boxes introduced in 1953 was retained right up to the end of production. These boxes had a scallop cut out of the outer side which originally was to allow for the wiper motor which very early on was situated on the outside of the inner dash area. It is unlikely that any of the original rubber floor mats are still available so we have designed a carpet set based on our very popular saloon sets which in conjunction with our other new items finishes off the interior beautifully.

NO	DESCRIPTION	PART NO
1	FRONT SEAT SQUAB COVER VINYL FIXED	SC740
2	FRONT SEAT BASE COVER	SC741
3	FRONT SEAT SQUAB COVER VINYL FOLDING	SC742
4	FRONT SEAT SQUAB PADDING	SF666
5	FRONT SEAT BASE FOAM CUSHION	SF655
6	FRONT SEAT BASE FRAME FOAM WRAP	SF660
7	PIRELLI SEAT STRAPS	ST654
8	PACKET OF FRONT SEAT CLIPS	C707
9	PAIR OF SCUTTLE PANELS	FL692
10	PAIR OF DOOR PANELS INC FIXING CLIPS	DP704
11	DOOR PULL EACH VINYL	DC703
12	PARCEL SHELF - RHD	PT721
12	PARCEL SHELF - LHD	PT722
13	PARCEL TRAY CRASH PAD BLACK ONLY	PT723
14	HEADLINING UP TO 1968	HL729
15	HEADLINING AFTER 1968	HL730
15	LATER TYPE SUNVISOR OUTER BRACKETS	SV732
16	GLOVE BOX LH	GB710
16	GLOVE BOX RH	GB711
17	PACKET OF 8 GLOVE BOX CLIPS	GB724
18	DOOR OR DRAUGHT EXCLUDER FOR TWO DOORS	DE733
19	DRAUGHT EXCLUDER CLIPS	DE736
20	2 DOOR WEATHERSTRIPS 2 PER WINDOW	WS738
21	WEATHERSTRIP CLIPS 12 PER WINDOW	WS740
22	CARPET SET RHD	CK748
23	CARPET SET - LHD	CK741
24	BULKHEAD SOUND DEADENING KIT	CK751
25	BITUMEN SOUND DEADENING PADS EACH	PT4008

COLOURS AVAILABLE
 BLACK AUTUMN LEAF

ACCESSORIES FOR ALL MODELS

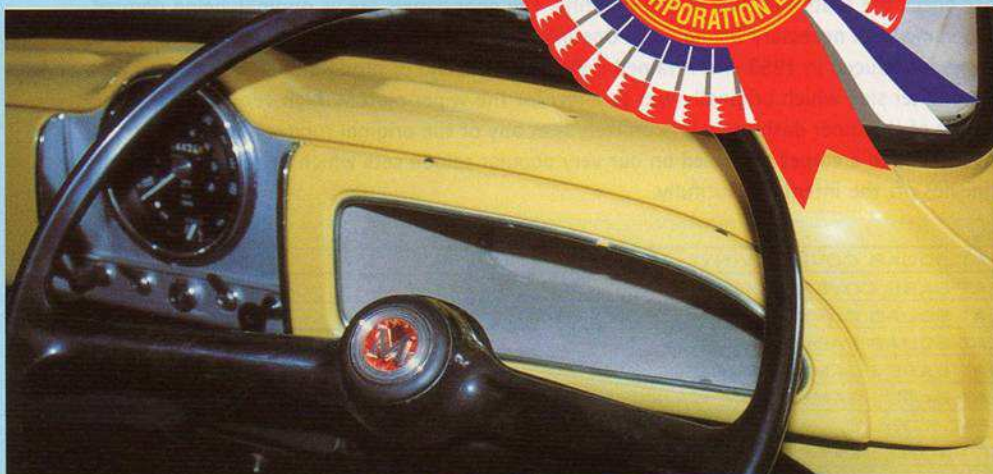

Late style glove box 1964-71



Early sunvisor pad 1949-57



Later style sunvisor pad complete with attachment brackets

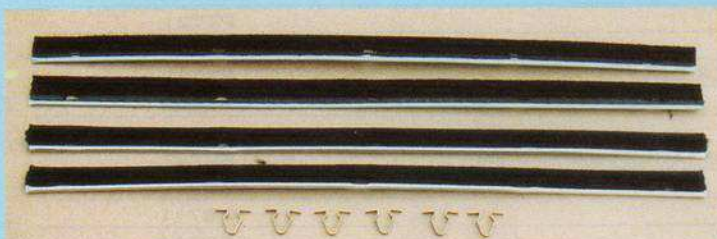

Set of four door weatherstrips with their clips



Selection of vinyl door pulls with their metal fixing bracket

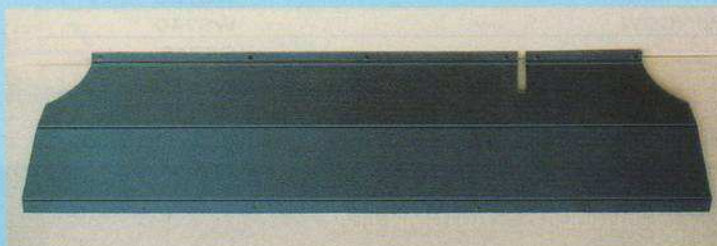

Early style parcel tray 1949-56

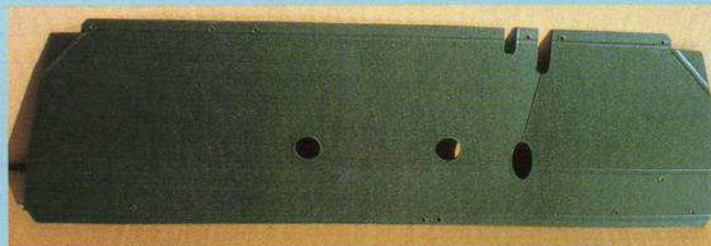

Late style parcel tray 1964-71



MADE IN ENGLAND

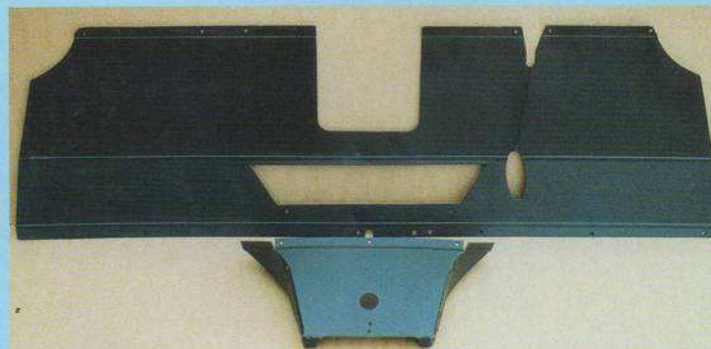

Mid range parcel shelf with the duct to cover the front of the heater unit

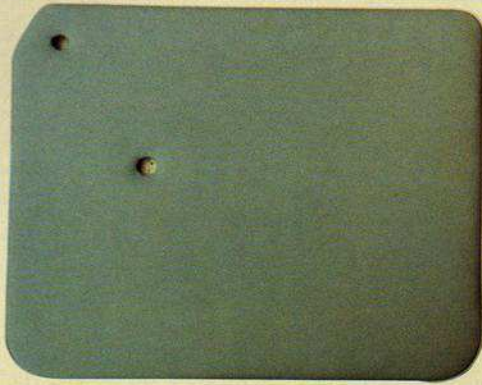

1949-59 Door Panel

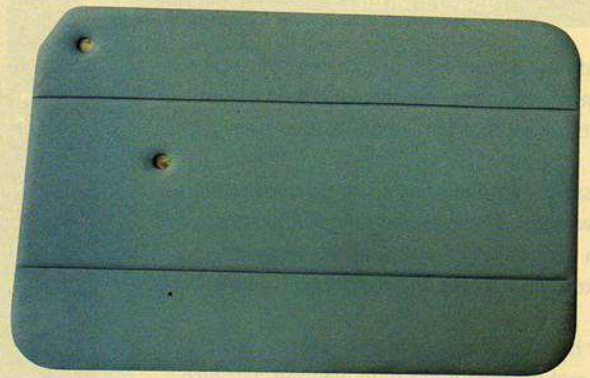

1960-62 Door Panel - All models

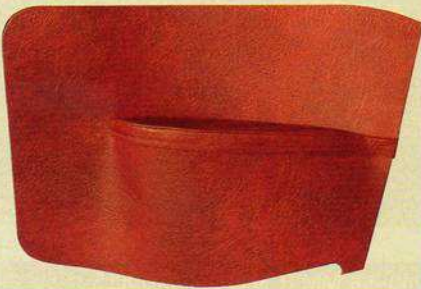

1949-62 Saloon Rear Quarter Panel

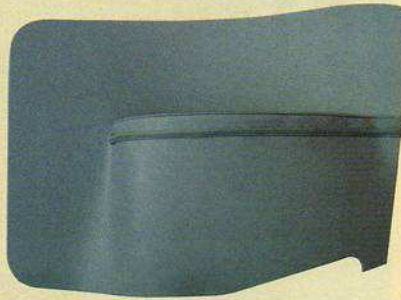

1953-63 Traveller Rear Quarter Panel

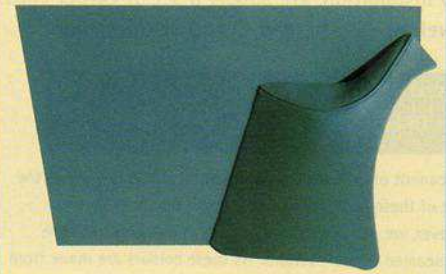

1964-71 Traveller Rear Quarter Panel

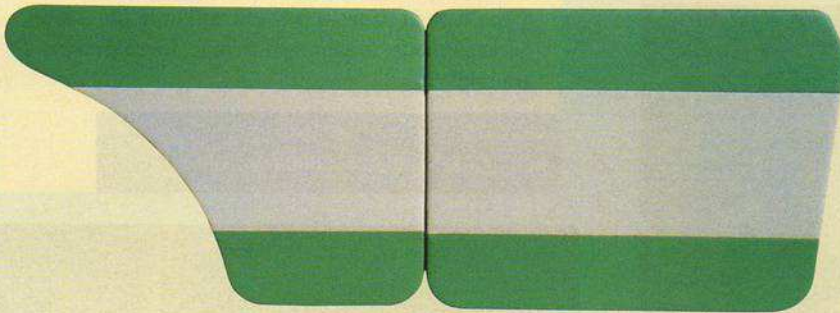

1962-64 Duotone Front and Rear Door Panels - 4 door saloon

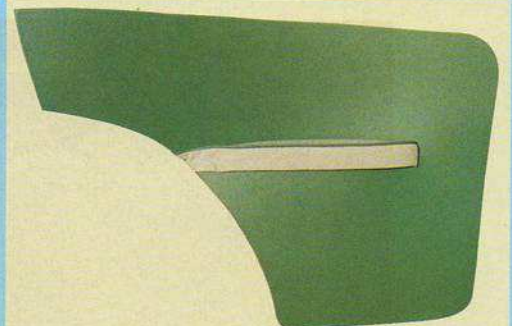

1962-64 Rear Quarter Panel

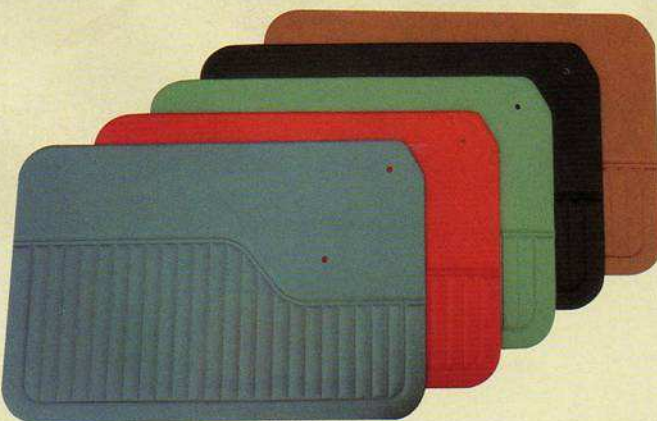

1964-71 Late Style Door Panels - All models



1964-71 Saloon Rear Quarter Panel

DELUXE CLASSIC CARPET SETS

1956-71 MODELS

Our brand new deluxe moulded carpet sets now include moulded tunnel carpets which fit around the whole tunnel section like a glove.

We also supply an underfelt kit to go underneath these new items. There are no longer any ugly seams on the tunnel carpets and the moulded handbrake section hides the handbrake cables.

The floor mats have a special PVC backing which not only makes them more hard wearing, but also waterproof from underneath.

The rest of the 11 piece kit is not PVC backed for easy installation. We supply a set of carpet clips as well as easy to read fitting instructions.

COLOURS AVAILABLE

BLUE GREEN DOVE GREY RED BLACK

(We cannot offer Brown or Navy in the moulded style as the make of these colours does not mould successfully. However, we can offer these colours in our previous style with seamed tunnel sections. As these colours are made from a tufted piled material these seams will not show.)

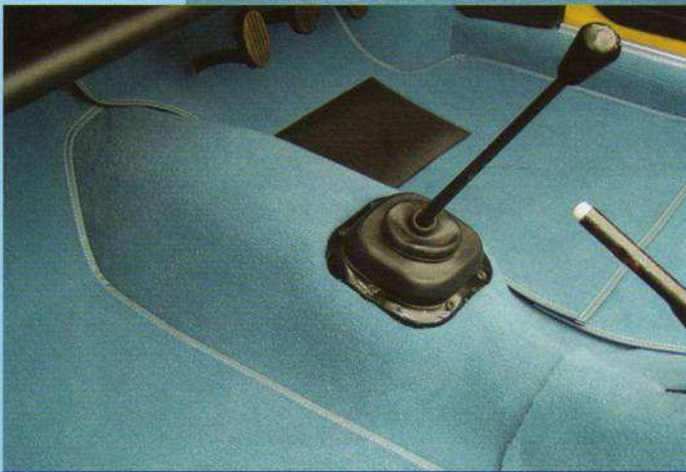
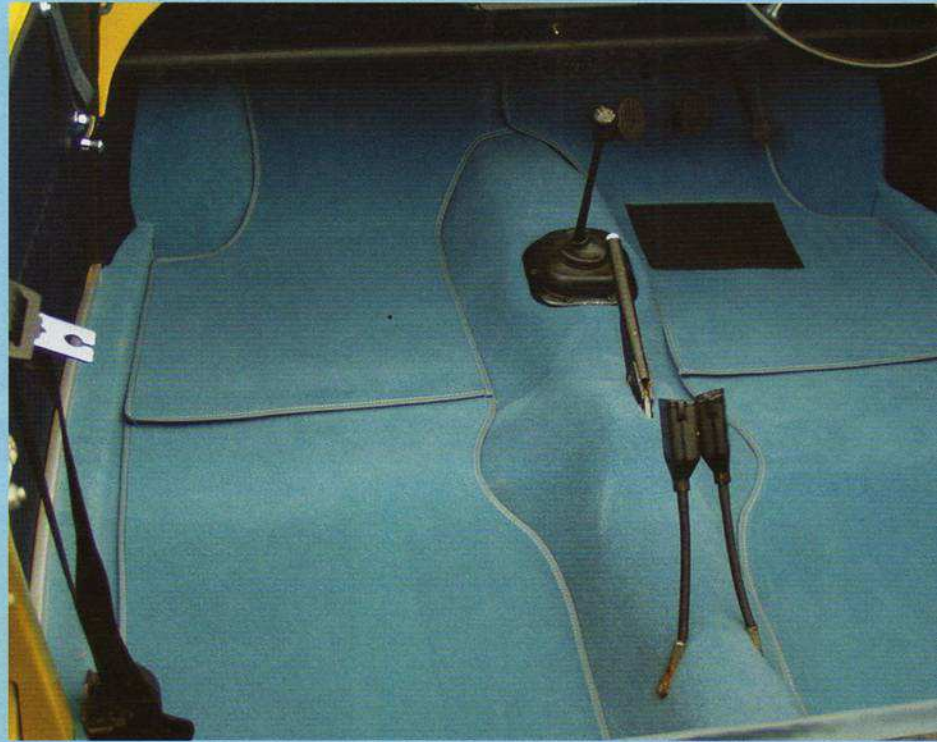

CLOSE UP VIEWS OF NEW MOULDED SECTIONS

1949-56 MM & SERIES II MODELS

We are not offering the moulded style carpet sets for these models, only original designs. If you look at pages 6 & 8 you will note the design for each model is slightly different. These designs are original.

COLOURS AVAILABLE

RED GREEN BLACK BROWN GREY





SALOON BOOT FLOOR CARPET WITH FIXINGS INCLUDED

COMPLETE INTERIOR TRIM KITS

The beauty of purchasing one of our 'Complete trim kits' is that not only do you receive everything to rebuild your interior but you will know that all the colours match because everything is brand new. The other great advantage is that when buying one of these kits there is a price saving of approximately 10 per cent.

Many customers now are replacing their front seats with our modern recliners mentioned earlier and purchasing them in conjunction with the complete interiors. If you wish to do this, please contact us so that we can advise you on a special price.

You may want to replace your original vinyl seats with leather covers – please see our price list for relevant details.



SEAT REBUILDING AND INTERIOR FITTING

We can also offer a seat refurbishment service. If you cannot get your seats delivered to us, we can arrange collection from your address, strip them down, inspect the frames, repair where necessary, repaint them and fit new covers, foams, straps, etc. Please contact us initially so that we can quote you the carriage and fitting charges.

We can also retrim your car if you wish. We generally only offer this service during the winter period (October–February), so that we can guarantee a reasonable turnaround. We would normally require your car for about two working weeks for a full retrim. Please contact us initially to discuss dates and costs involved.



TRAVELLER GREY HARDURA REAR COMPARTMENT COVERING KIT





TELEPHONE ORDERING

NEWTON COMMERCIAL

EASTLANDS INDUSTRIAL ESTATE

LEISTON, SUFFOLK IP16 4LL

TEL: 01728 832880 FAX: 01728 832881

WWW: NEWTONCOMM.CO.UK

EMAIL: NEWTONCOMM@ANGLIANET.CO.UK



BRITISH MOTOR
HERITAGE APPROVED