

NEWTON COMMERCIAL
Capri 1 Piece Moulded Carpet
FITTING INSTRUCTIONS

Please read these instructions carefully to give an idea of the sequence of events. When removing clips screws and bolts etc.
 Please remember to put them in a plastic bag label and store them safely for re-use.
 Take some pictures to remind you how things fitted

SEAT AND CENTER CONSOLE REMOVAL



The first part of the removal process is to remove your seats. Firstly move your seat forward and remove the two 10mm bolts then move the seat back and remove the front two bolts, the seat can now be taken out of the car.



Remove the rear seat base by undoing the 2 screws either side.



Pull the belts through there slots and the base is now free to come out of the car.

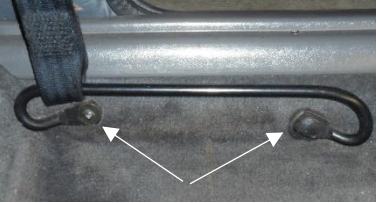

Undo the bolt and screw holding in the seat belt mount and remove.



Then remove the bolt from your seat belt mount on either side of the tunnel.



There are two variations of the center console that go along with the 1 piece carpet, if you have the one without the clock and gear lever surround please go straight to removing the gear lever knob.

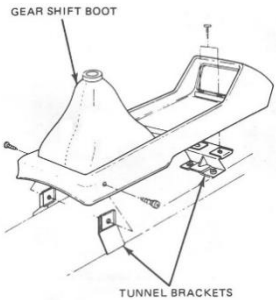

If you have this type of console please follow the next instructions.

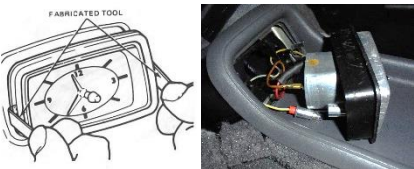

A pair of tweezers or any tool that can grab onto the lip of the clock will be needed for this step, this will allow you to pull the clock out of its hole. Disconnect the clock and remove.

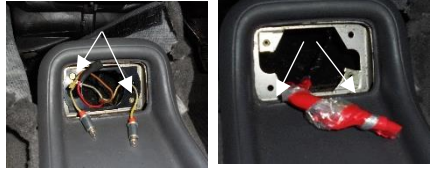

Undo the two screws holding the clock mount in and remove. The cables can now be wrapped together so they stay out of the way. Once this is done remove the two screws that situate just under the clock which hold the console to the tunnel.



Remove the two screws by the gear lever.



Undo the gear knob and remove. The tunnel should now pull free. Once free remove the mounting plates.



Remove the handbrake cover and grip if there is one.



Next you will need to undo the four screws which hold on the sill plates, remove the sill plates from both sides of the car.

All of the screws and bolts will now have been removed and will allow for the carpet set to come out. Start with pulling the carpet away from the rear quarter panels.



Now the carpet has been fully removed we can focus on removing the underfelt. Remove all of the pieces on the floor first.



Then starting with the passenger side, you will need to cut the old underfelt in line with the glovebox support rails being careful not to cut any wires. This section will now be removable.



Next is the driver's side, start your cut on the tunnel and work up to the left locating tag, cut down to the middle tag then cut all the way along in a straight line to the body panel. This section will now be removable.



The tunnel section will be the last piece of underfelt remaining and should pull straight out with nothing else needing to be done.

UNDER FELT FITTING

Take this opportunity to make any repairs to your floor as necessary. Please make sure that floorpan is dry before fitting your new underfelt.

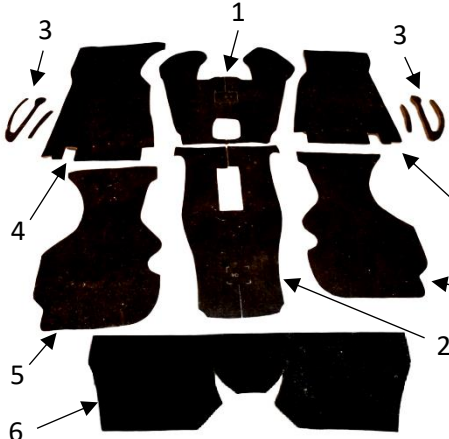

Picture shows and identifies all components of your new underfelt kit.

1. Front tunnel section
2. Rear tunnel section
3. Floor filler felt
4. Front footwell felt
5. Rear floor well felt
6. Rear seat base section

Please note - The picture is an underfelt for a two piece carpet the one piece will have no cut outs in the tunnel section.

First we need to start off with number 1 - the front tunnel section. Place this section onto the tunnel making sure the slits in the center of the felt line up with the holes at the back along with the join at the front near the heater matrix. Once happy with the fit glue down.



Secondly use number 2 - the rear tunnel section. Line up the cuts in the underfelt along with the tunnel and glue down.



Use part's 3 - the floor filler felt to fill in the pressings pressed into the floor pan. These can be glued in place on their respected sides.



Place the drivers side mat from number 4 into the car and trim back the felt to clear the pedal assembly. Furthermore where the underfelt overlaps on the tunnel section mark and cut to allow the underfelt to sit flush.



The same can now be done with the passenger's side front footwell underfelt. Make sure you are happy with the placement on both sides and glue them down.



Pieces number 5 - the rear floor well sections, can be laid into place on the floor well and glued in. Minimal trimming if any is needed.



The rear seat base section can now be glued down into place.

MAIN CARPET AREA FITTING



Start by laying the carpet in the car and feeding the front of the carpet under the heater matrix, Make sure the carpet sits nicely over the cross member and seat mounts.



Once you are happy with how the carpet is sitting lift the driver's side and spray glue onto the top of the tunnel and stick down.



Make sure the location is correct across the cross member again and if all is correct glue down the side of the tunnel and stick down.

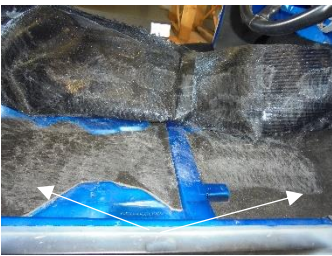

Next glue down the footwell sections all the way down the car to the outer seat mount and then stick down.



Now these sections are glued down you can cut the hole out for the steering column assembly.



Once the steering column hole is cut the piece over the foot rest pressing can be glued and stuck down.

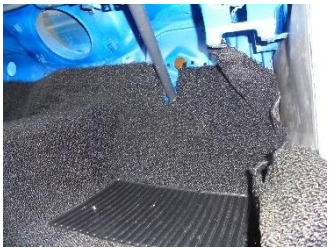

If you are fitting a loop pile style carpet lightly glue the scuttle area as this will need to be trimmed. If you are fitting a nylon carpet this can be glue as normal and stuck down, no trimming is needed.



With the loop pile carpet, place the scuttle panel in place and mark where you need to trim. We would advise trimming in stages so not to cut off too much.

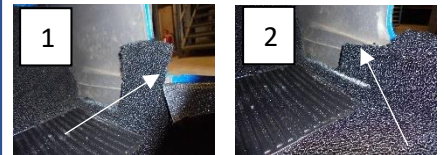

The next step for both carpets will be to trim the sill area – firstly start by making an incision at the front of the sill, cut this down flush with the sill. Secondly continue the cut along toward the front of the car. This will leave roughly a 100mm tab



Once the front sill section has been trimmed to size glue the outer seat mount and the sill section.



At this point the 100mm tab can be fed behind the scuttle panel.



Glue the rear area of the carpet and stick down. The lip on the rear section should also be glued.



Next you will need to trim the top of the sill so that this sits flush, please note the B post foot-notes will be where you need to stop cutting.

This is now the driver's side complete, repeat the previous steps for the passenger side minus cutting the hole for the steering column.

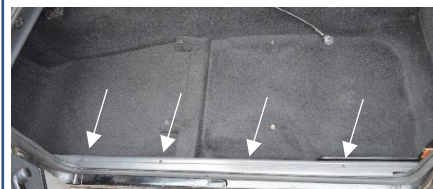

Now the passenger's side is fully fitted you can now refit the sill plates using the four screws removed earlier.

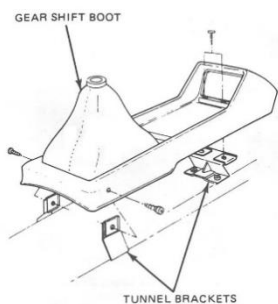

Locate the holes needed for the center console mounting plates and refit.

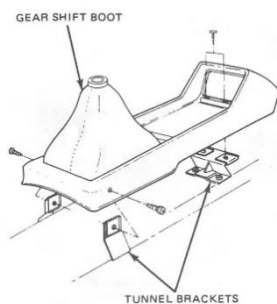

Refit the center console and all relevant screws.



Next refit the wires back into the clock and refit into the hole.



Screw the gear lever knob back on and any gaiters or surrounds back onto the hand brake lever.

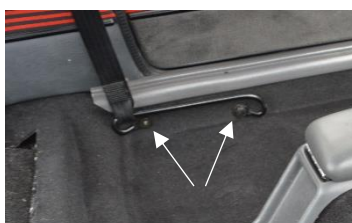

Locate the seat belt holes in the sill and make a hole in the carpet big enough to fit the bolt and screw through. The seat belt mounts can now be refitted.



Then locate the seat belt holes in the tunnel, again make a hole in the carpet big enough to fit the bolt through. The seat belts can now be screwed into place.

Find the insertion holes for the front seats and create a hole for the bolts. There is two on the front and two on the back.



The carpet has now been fully fitted!

YOU HAVE NOW FINISHED FITTING YOUR BRAND NEW NEWTON COMMERCIAL CARPET SET.

HAPPY MOTORING!