

Package Contents

Filter housing, 2-3/4" port x 3/8" brass (lead free) compression fittings installed in housing, mounting bracket attached to housing, ProMax™ FULL SPECTRUM™ filter cartridge installed in housing, 30" x 3/8" compression fitting flex hose and filter cartridge replacement wrench

Tools and Hardware Required

Adjustable wrench, screwdriver, Teflon tape, 4 - screws for mounting bracket to cabinet, 1/2" drill bit when using optional faucet

System Specifications

- Overall height from bottom of housing to top of bracket is 18.5". Diameter is 7.25"
- Type of installation: Under counter – Inline or with optional separate faucet - for cold water use ONLY
- Space Requirement: System requires minimum of 2" below sump(housing) for filter replacement
- Maximum Working Pressure: 860 KPA (125 psig)
NOTE: Should your water pressure exceed 80 psig, install a pressure reducing valve before installing the system
- Minimum Working Pressure: 137 KPA (20 psig)
- Minimum Working Temperature: 5° C (41° F)
- Maximum Working Temperature: 38° C (100° F)
- Recommended Flow Rate: 0.2 – 1.0 gpm
- Contaminant Reduction: Refer to Lab Reports
- Filter Life Expectancy: Up to 1 year with inline installation and up to 2 years with separate faucet installation
- Replacement filter: PM-FS10-RF

STANDARD INLINE SYSTEM

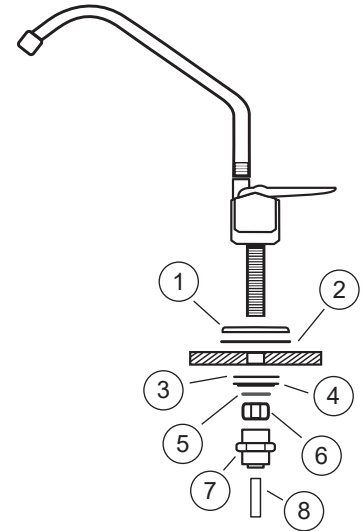

1. Face Plate
2. Large Rubber Washer
3. Small Rubber Washer
4. Plastic Washer
5. Star washer
6. Steel nut
7. Quick connect fitting
8. 3/8" tubing

OPTIONAL SEPARATE FAUCET KIT

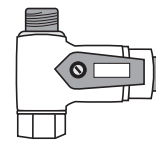

T-Valve optional. Shown in OPEN position

Designed to fit under sink or in basement. Do NOT install where the temperature could fall below freezing as damage could result. No power required. For use with cold potable water only.

READ COMPLETELY BEFORE INSTALLING OR USE.

CAUTION: Before beginning the installation, turn OFF the cold water supply under your sink or your house supply at the meter. Open the cold water faucet to release any water pressure.

WARNING: Do not use water source that is microbiologically unsafe or of unknown quality without adequate disinfection before or after the system. For specific health requirements, consult your healthcare professional. Check and comply with any installation state or local codes that may apply.

SHOULD YOU HAVE QUESTIONS ABOUT INSTALLING YOUR PROONE SYSTEM, PLEASE CONTACT TECHNICAL SUPPORT AT 800-544-3533 X27 OR EMAIL SUPPORT@PROONEUSA.COM FOR ASSISTANCE.

1.0 Standard Inline Installation

Install Filter Housing – see diagram A on page 3

1. Select a suitable location for the filter housing under the sink.

NOTE: Location should be reasonably accessible for filter replacement. When mounting housing to cabinet, leave a minimum 2" space below sump/filter housing for removal of sump for maintenance and filter replacement and orientate to match the desired flow direction.

DO NOT INSTALL where temperatures fall below freezing as damage to the system will occur.

NOTE: The flow arrow and IN/OUT are embossed on the top of the black plastic housing head. **DO NOT** reverse.

NOTE: Filter cartridge is pre-installed at the factory.

WARNING: Be sure to turn off your water supply or manual shut off valve for your cold water before proceeding with the installation. If your plumbing does not include a manual shut off valve at the sink, we recommend one be installed before proceeding.

2. Secure the bracket attached to the filter housing assembly to the side of the sink cabinet in the desired location. Depending on your installation, use appropriate fasteners not supplied with your system. Be sure to securely mount the housing using the 4 mounting holes as it will be heavy when full of water.

3. Remove existing flex hose connection at the cold water shut off valve and attach to the **OUT** side of your filter. Filter housing requires a 3/8" compression fitting on the end of your existing flex hose.

4. Using the flex hose included with your system, attach one end to the **IN** side of the filter housing and the other end to the manual shut off valve. The flex hose requires a 3/8" compression fitting.

MAKE SURE FITTINGS ARE TIGHTENED SECURELY. DO NOT OVER-TIGHTENED.
GO TO STEP 3.0 – START-UP to complete the installation.

2.0 Inline Installation With Separate Faucet (Optional Kit) –

See diagram B on page 3 for Optional Faucet

Begin installation by following steps 1 & 2 in section 1.0 above. Then continue with 2.0 below.

1. Disconnect existing flex hose connected to your manual cold water shut off valve or cold water supply.

2. Install the T-valve as shown in Diagram B on page 3. Requires 3/8" compression fitting size.

3. Re-connect existing flex hose to the outflow side of the T-valve. Other end should remain connected to existing faucet.

4. Prepare a piece of 3/8" plastic tubing (included) to fit between the quick connect push fitting on the T-valve and the IN side on the water filter housing - **ADD additional 1-1/2"** to tubing length as tubing will travel about 3/4" into each fitting to seat properly.

5. Insert one end of plastic tubing into the quick connect on the T-valve - press in firmly.

6. With other end of tubing, remove nut and compression washer from filter housing. Slide nut first onto tubing, then slide compression washer onto tubing. Insert tubing firmly into brass fitting (lead free) on housing. Slide compression washer and nut onto threads and begin to tighten nut using wrench. Tighten securely. **DO NOT** over tighten.

7. Select a suitable location for the drinking water faucet as close to the sink as possible allowing convenient space under the sink for assembly. The spout of the faucet should be able to reach the sink. A 2" flat area is required to mount the faucet. Check for clearance, then drill the sink top with a 1/2" bit to accommodate the faucet inlet pipe.

8. See Optional Faucet details and diagram on page 1 for installation on the faucet through the sink top.

9. Remove the plastic quick connect adaptor, the brass nut and the lock washer from the inlet pipe.

10. Insert the faucet stem through the sink top to seat the rubber washer.

11. Replace the lock washer and brass nut and tighten firmly with a wrench.

12. Attach the plastic quick connect to the threaded stem of the faucet using Teflon tape (not supplied)

13. Prepare a piece of 3/8" plastic tubing (included) to fit between the quick connect push fitting on the faucet and the **OUT** side on the water filter housing - **ADD additional 1-1/2"** to tubing length as tubing will travel about 3/4" into each fitting to seat properly. Insert end of plastic tubing into the quick connect push in fitting on faucet. Press firmly.

14. With other end of tubing, remove nut and compression washer from filter housing. Slide nut first onto tubing, then slide compression washer onto tubing. Insert tubing firmly into brass fitting (lead free) on housing. Slide compression washer and nut onto threads and begin to tighten nut using wrench. Tighten securely. **DO NOT** over tighten.

GO TO STEP 3.0 – START-UP to complete the installation.

3.0 START-UP

1. Slowly turn on your water supply or manual shut off valve.

2. Check for leaks before proceeding

3. Press the RED button on top of the black housing head to allow trapped air out of the system.

4. Slowly turn on your cold water faucet.

5. Water should start flowing out of faucet.

6. Allow water to flow for a few minutes to flush out the system before using the water. Some residual particles may be expelled during this flushing process. This is normal.

7. **Your system is now ready for use.**

DIAGRAM A

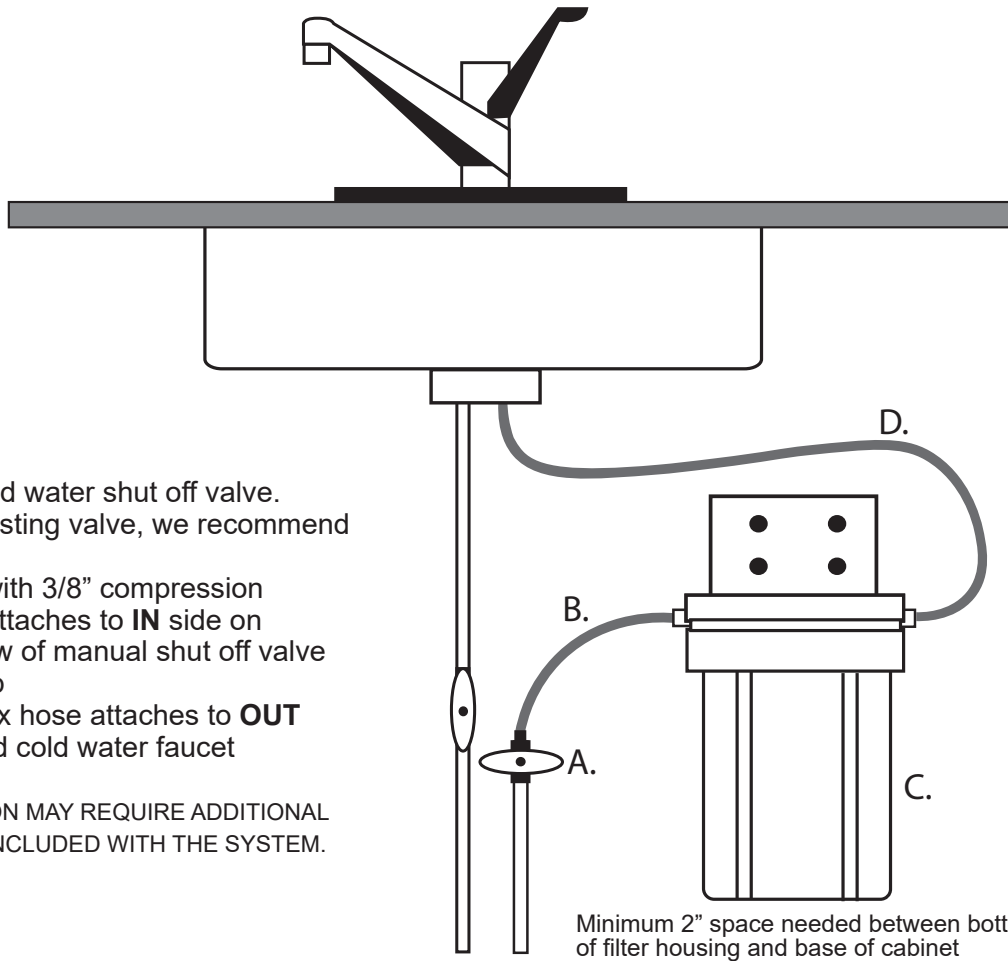

- A. Existing manual cold water shut off valve.
If there's not an existing valve, we recommend one be installed.
- B. Braided flex hose with 3/8" compression fittings (included) attaches to **IN** side on housing and outflow of manual shut off valve
- C. Filter housing/sump
- D. Existing braided flex hose attaches to **OUT** on filter housing and cold water faucet

YOUR INSTALLATION MAY REQUIRE ADDITIONAL
HARDWARE NOT INCLUDED WITH THE SYSTEM.

Minimum 2" space needed between bottom
of filter housing and base of cabinet

DIAGRAM B

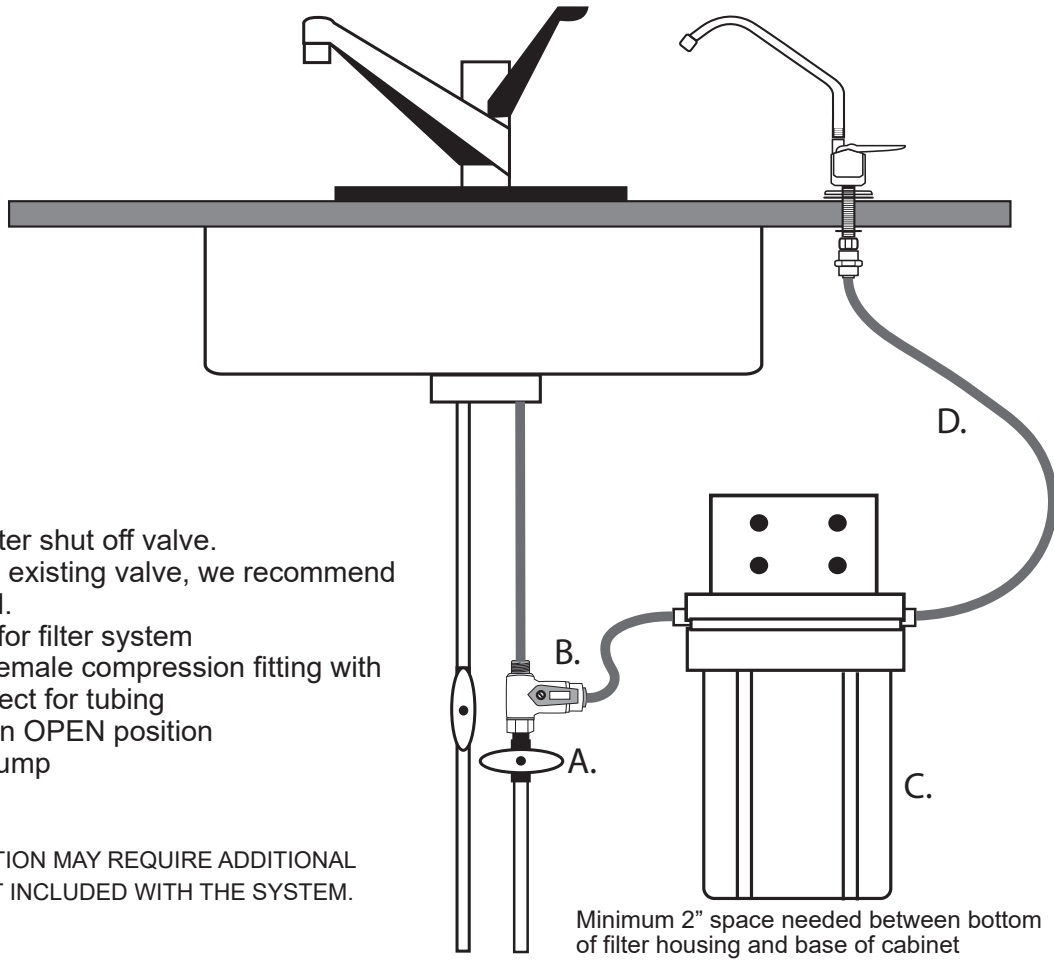

- A. Manual cold water shut off valve.
If there's not an existing valve, we recommend one be installed.
- B. Shutoff T-valve for filter system
3/8" male and female compression fitting with
3/8" quick connect for tubing
Handle shown in OPEN position
- C. Filter housing/sump
- D. Plastic tubing

YOUR INSTALLATION MAY REQUIRE ADDITIONAL
HARDWARE NOT INCLUDED WITH THE SYSTEM.

Minimum 2" space needed between bottom
of filter housing and base of cabinet

3.0 How To Replace The FS-10 Filter Cartridge



WARNING: Water pressure must be released prior to unscrewing the sump.

1. Turn off the water supply or manual water shut off valve. Turn on faucet to release water and pressure.
2. Press the RED button on top of the black housing head to release any remaining pressure in the filter housing.
3. Using the supplied wrench ONLY, slowly unscrew the filter housing sump by turning counterclockwise until removed.
4. Drain water from filter housing/sump over sink and remove old filter cartridge by gently pulling it out from the housing and discard. Make sure inside of sump is clean. OK to wash with warm, soapy water and rinse well.
5. Insert new filter cartridge into housing. Make sure cartridge end with washer is installed facing upward in housing.
6. Lubricate the O-ring and sump threads with food grade silicone grease.
7. Using the supplied wrench ONLY, screw housing/sump back onto filter head clockwise securely. Hand tighten, firmly, being careful not to cross thread. DO NOT over tighten.
8. Slowly turn on water supply or manual water shut off valve.
9. Open the cold water faucet downstream to release any air.
10. Turn off faucet and press RED button on top of the black housing head to allow any trapped air out of the system.
11. Slowly turn on your cold water faucet. Water should start flowing out of faucet.
12. Check for any leaks.
13. Allow water to flow for a few minutes to flush out the system before using the water. Some residual particles may be expelled during this flushing process. This is normal.
14. **Your system is now ready for use.**

THIS END UP

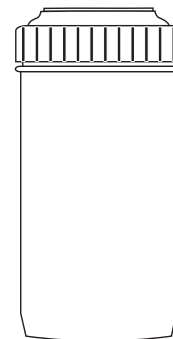

FAQ's

1. How do I know when to replace my filter cartridge?
The actual life expectancy of your filter will vary depending on the specific chemistry and level of contaminants present in your water source. We recommend you replace your filter up to 12 months for inline application and up to 18 months for separate faucet application. You may also consider replacing your filter should the following occur.
 - a. When the flow rate diminishes
 - b. When you notice a change in taste or odor
2. How to maintain your system
 - a. When changing the filter, we recommend you lubricate the O-ring and sump threads with food grade silicone
 - b. We recommend you replace the filter housing every 5 years.

ProOne® LIMITED WARRANTY. Lincoln-Remi Group, LLC d/b/a ProOne® Water Filters ("PO") sells its products with the intent that they are free from defects in materials and workmanship under normal use and care. PO provides a limited warranty to the original retail purchaser of ProOne® products ("Customer") of those ProOne® products described in this Limited Warranty when purchased from ProOne® or an authorized ProOne® dealer. PO will repair or replace any ProOne® product, at its sole discretion during the warranty period under the following conditions:

1. Product Name: FS10 Under Counter System
2. If during two (2) years following the purchase of a ProOne® FS10 filter system and one (1) year for the FS10 replacement filter cartridge excluding the filter media, PO will replace or repair any component in this system when found to be defective by ProOne® during the warranty period,
3. No warranty is given as to the service life or performance of any filter media or any filter element because performance of ProOne® filters will vary with water conditions and water consumption. Customer is encouraged to visit the Lab Report Disclaimer under Terms and Conditions at www.prooneusa.com.
4. Any damage caused by misuse or abuse; accident; improper installation; dropped product; failure to follow recommended installation or provide recommended maintenance; transportation damage; neglect; environmental conditions; or any other conditions whatsoever that are beyond the control of PO are excluded from this warranty.
5. This express limited warranty is the sole and exclusive warranty.
6. ALL OTHER WARRANTIES, WHETHER EXPRESS OR IMPLIED, INCLUDING BUT NOT LIMITED TO, ANY IMPLIED WARRANTIES OF MERCHANTABILITY, FITNESS OR FITNESS FOR ANY PARTICULAR PURPOSE OR ANY OTHER POTENTIAL OBLIGATION ON THE PART OF PO WITH RESPECT TO PRODUCTS SOLD BY PO ARE DISCLAIMED. EXCEPT FOR ANY EXPRESS WARRANTIES, ALL ProOne® PRODUCTS ARE SOLD "AS-IS". PO shall not be held liable for any incidental, consequential or special damages of any sort whatsoever. The liability of PO is limited to the original retail purchaser and to the repair or replacement of defective components only during the Warranty Period. Labor charges incurred are not covered under this warranty. No refunds will be given at any time to anyone other than the original retail purchaser, except as provided in the refund policy of ProOne®. Please visit Refunds and Returns under Terms and Conditions at www.prooneusa.com. The Customer is also encouraged to review the Lab Report Disclaimer under Terms and Conditions at www.prooneusa.com. The liability of PO terminates upon the expiration of the Warranty Period or transfer of product ownership.
7. To obtain warranty service on, or replacement of a ProOne® product, Customer should contact ProOne® customer service by email to support@prooneusa.com to confirm eligibility of warranty. Customer may be asked to send, at the sole expense of the Customer: (a) the product including its original packaging; and (b) the dated sales receipt as proof of purchase, and a prepaid return package, to the following address: ProOne, 1200 Benstein Rd, Commerce Twp., MI 48390. NO C.O.D's will be accepted.
8. This warranty provides you with specific legal rights. You may have additional rights which may vary from country to country. Because of individual country laws and regulations, some of the above limitations and exclusions may not apply to you. For any warranty questions, please call 1-800-544-3533 or email to support@prooneusa.com.

Attention CA, IA and WI Consumers. In compliance with states' law, ProOne products are sold and shipped to residents of these states without any health related performance claims except for aesthetics including chlorine reduction and improvement with taste, odor and sediment. Other states may apply.