

Countertop & Under Counter Systems

Countertop

Mini Countertop

Under Counter



ProOne®

WATER FILTERS

Instructions

Customer Support:
+1 (800) 544-3533 or
support@prooneusa.com

Index

ProOne®/Coldstream Filter Element	3
ProOne®/Coldstream Standard Countertop System, ProOne®/Coldstream Mini Countertop System	4
Package Contents	
Specifications	
Before Installation	5
Installation	
Conditioning Your Filter Element	
Using Your System	
How to Clean & Replace the Filter Element	6
Removing, Cleaning, Conditioning & Replacing Your Filter Element	
ProOne®/Coldstream Standard Under Counter System (Inline Installation)	7
Package Contents, Specifications. Tools & Hardware	
Installing Your Filter Housing	8
Connecting The System With Existing Faucet	9
Start Up	
ProOne®/Coldstream Standard Under Counter System (Optional Faucet)	10
Package Contents, Specifications. Tools & Hardware	
Installing Your Filter Housing	11
Connecting the System, T-Valve & Hammer Arrestor (optional)	12
Installing the Faucet	13
Installing the Connecting Tube	14
Using the Faucet	
Start up	
How to Clean & Replace the Filter Element	
Removing, Cleaning, Conditioning & Replacing Your Filter Element	15
FAQs	16

ProOne®/Coldstream Filter Element

The ProOne®/Coldstream Filter element offers the most advanced ceramic filter technology featuring:

- 2-layer outer ceramic shell with “scrub through” usage indicator. Once your filter element reaches the white layer, it’s time to replace it
- Ceramic shell is silver infused to help prevent growth of bacteria
- Outer layer of the ceramic shell acts as a pre-sediment filter and is cleanable
- Inner core proprietary carbon block technology
- Filter element is cleanable and reusable
- Life expectancy for standard ProOne®/Coldstream filter element is up to 2600 gallons and up to 750 gallons for the Mini ProOne®/Coldstream filter element

CAUTION: Do not install where exposure to freezing may occur as damage will result.

CAUTION: Before beginning the installation, turn OFF the cold water supply under your sink or your house supply line at the meter. Open the cold water faucet to release any water pressure.

CAUTION: If you hear any noises such as banging or rattling of pipes when turning on or off any water faucet or device, you may have a water condition known as “water hammer”. Water hammer is known to cause damage to plumbing, fittings and even water devices. We highly recommend adding a “water hammer” arrestor device(optional) to your ProOne® under counter system whether or not you are aware of this condition.

NOTICE: Installation and plumbing should comply with all local laws and regulations.

WARNING: Do not use water source that is microbiologically unsafe or of unknown quality without adequate disinfection before or after the system. For specific health requirements, consult your healthcare professional.

ProOne®

W A T E R F I L T E R S

ProOne®/Coldstream Standard Countertop & Mini Countertop System

Package Contents

- (a) Filter Housing
- (b) Diverter Valve
- (c) Hose
- (d*) ProOne®/Coldstream Filter Element (*Installed)
- (e) Housing Wrench
- (f) Standard Faucet Adapter
- (g) Outlet spout
- (h) Selector
- (i) Not included: Universal Adapter (Optional)

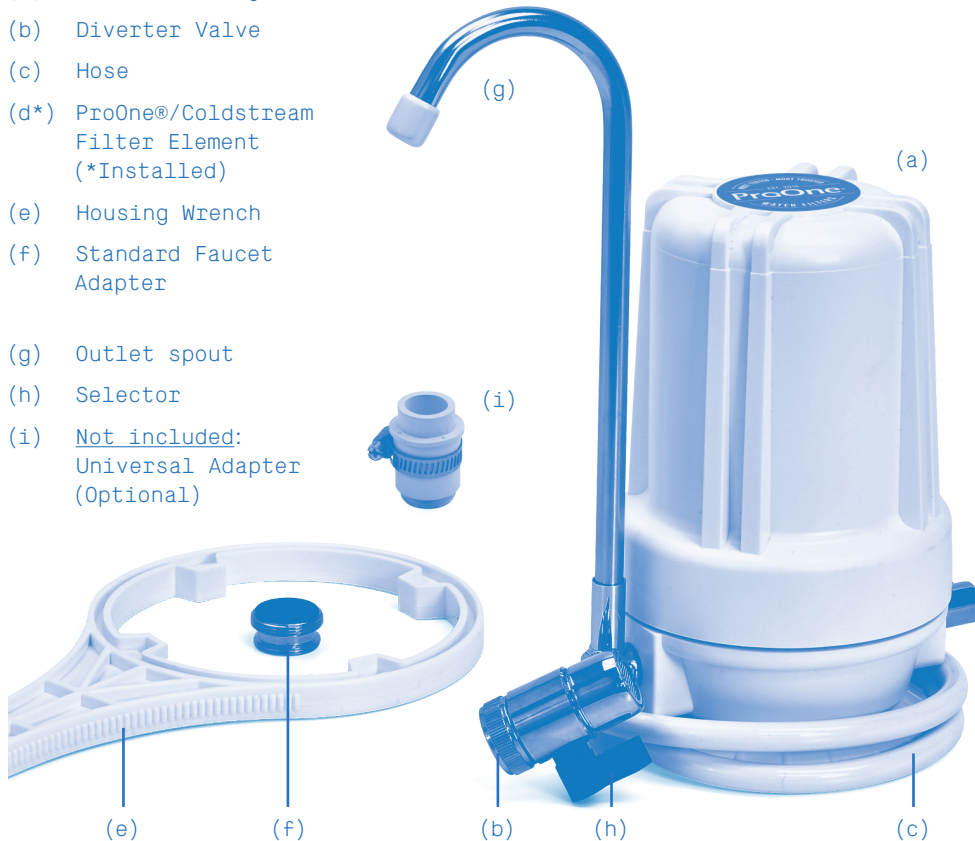

Specifications

Type of installation:	Countertop Faucet
Maximum Working Pressure:	75 psi
Minimum Working Pressure:	10 psi
Maximum Working Temperature:	38° C (110° F)
Minimum Working Temperature:	5° C (41° F)
Recommended Flow Rate:	0.2 – 1.0 gpm
Contaminant Reduction:	Refer to Lab Report
Standard/Mini Filter Life Expectancy:	2600 gallons / 750 gallons
Standard Replacement Filter Element:	POC-737RF
Mini Replacement Filter Element:	POCM-737RF

Before Installation

- Designed to fit most faucets with removable aerator
- No power required
- Quick and easy installation. Just connect to your faucet
- No tools required
- Includes standard faucet adapter
- Optional universal adapter available
- For use with cold potable water only
- For specific health requirements, consult your healthcare professional

Installation

1. Select a location for the System. The System is designed to be free standing near a sink so that water from the System outlet can drain into your sink.
2. Connect the System (filter element is pre-installed). Remove the aerator from your faucet. Screw the diverter valve(b) onto your faucet if a male thread is visible. If not, use the adapter(f) provided with your System and screw diverter valve into the adapter. Do not over-tighten.
3. If your faucet does not have a removable aerator or the adaptor does not fit, please contact our customer support team to request a universal faucet adapter(g) at 1-800-544-3533 (ext: 127) or email support@prooneusa.com.

Conditioning Your Filter Element

1. Hold the unit upside-down over the kitchen sink for step 2.
2. Turn on the cold tap with low to moderate pressure, rotate the selector(h) on the diverter valve to allow water to slowly fill the unit for the first time. It may take a few minutes for water to flow through the outlet spout(g).
3. Once water begins to flow through the outlet spout, place system on counter next to sink and allow water to run 5 minutes or 2 gallons and discard. This will expel any trapped air and condition the filter element for use.
4. System is now ready for use.

Using Your System

To dispense water from the system, rotate the selector (h) on the diverter valve(b) allowing water to flow through the System and exit the outlet spout(g). When turned off, dripping may occur from spout, this is normal and will stop quickly.

How to Clean & Replace Your Filter Element

Your ProOne®/Coldstream filter element consists of 2 layers. The outer layer acts like a pre-sediment filter element and is cleanable/reusable. Periodic cleaning is recommended but especially if you see a build up of discolored particulates on the outer blue surface of the filter element.

Once you scrub/clean through the blue layer and begin to see white, it's time to replace the filter element.

Removing/Replacing Your Filter Element

With the cold tap turned off, and the diverter valve is in the off position, hold the System unit upside-down over the sink.

Unscrew the housing(a), which will be full of water, using wrench(e) from the base. The ProOne®/Coldstream filter element(d*) can now be removed by gently pulling it away from the base.

Cleaning Your Filter Element

While holding the filter element under running water in one hand, use the dark green side of the scrubby sponge included and gently scrub the entire outer ceramic surface. You should see any residue build up slowly disappear as you scrub the filter element.

Rinse well after scrubbing.

Once cleaned, re-insert the filter element (the end cap of the filter element with the hole goes into the base) into the housing and securely tighten the filter housing back onto the base. Use the supplied wrench to tighten. DO NOT over tighten.

Replacing Your Filter Element

Insert end with hole side of the ProOne®/Coldstream filter element into the base of the filter system.

Please make sure that the washers on each end of the filter element have been inserted correctly. After it has been installed, please condition the new filter element as explained on page 5.

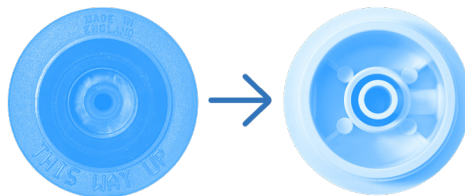

ProOne®/Coldstream Standard Under Counter System (Existing Faucet)

Package Contents

- (a) Filter housing
- (b) 3/8" compression fittings attached
- (c*) ProOne®/Coldstream Filter (*Installed)
- (e) Water Hammer Arrestor with connecting tube (optional). For use where the water condition known as "Water Hammer" may be present. Contact ProOne® support at support@prooneusa.com to find out more about "Water Hammer"
- (g) Mounting bracket (attached)
- (h) 30" Braided hose with 3/8" female compression fittings on both ends

Specifications

Type of installation: Under Counter with Existing Faucet

Using existing faucet

Maximum Working Pressure: 125 psi (860 kpa)

Minimum Working Pressure: 20 psi (137 kpa)

Maximum Working Temperature: 38° C (110° F)

Minimum Working Temperature: 5° C (41° F)

Recommended Flow Rate: 0.2 - 1.0 gpm

Contaminant Reduction: Refer to Lab Report

Standard Life Expectancy: 2600 gallons

Standard Replacement Filter: POC-737RF

Tools & Hardware

The following tools & hardware may be required:

- Philips screw driver
- Adjustable wrench
- Teflon tape
- Safety glasses

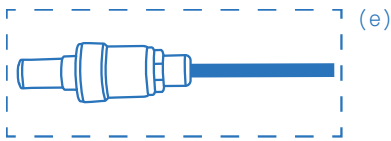

Warning

Use with cold potable water only. Do not use a water source that is microbiologically unsafe or of unknown quality without adequate disinfection before or after the system. For specific health requirements, consult your healthcare professional.

Caution

Before beginning the installation, turn OFF the cold water supply under your sink or your house water supply at the meter. Open the cold water faucet to release any water pressure.

Installing Your Filter Housing

1. Select a suitable location for the filter housing(a) under the sink.

NOTE: location should be reasonably accessible for filter replacement. When mounting housing to cabinet, make sure to leave enough space below filter housing (min. 2 inches) for maintenance and filter replacement.

DO NOT INSTALL where temperatures fall below freezing as damage to the system will occur.

NOTE: The flow arrow and inlet/outlet are embossed on the top of the white plastic head.

2. Secure the mounting bracket(g) to the side of the sink cabinet in the desired location.

Connecting The System To Your Existing Faucet ^(Diagram A)

1. Disconnect existing flex hose connected to your manual cold water shut off valve.
2. Leave other end connected to your faucet.
3. Install one end of the enclosed flex hose to your cold water shut off valve.
4. Connect the other end of the flex hose to the inlet side of the System.
5. Connect the loose end of your original flex hose going to the cold side of your existing faucet to the outlet side of the System.

Diagram A:

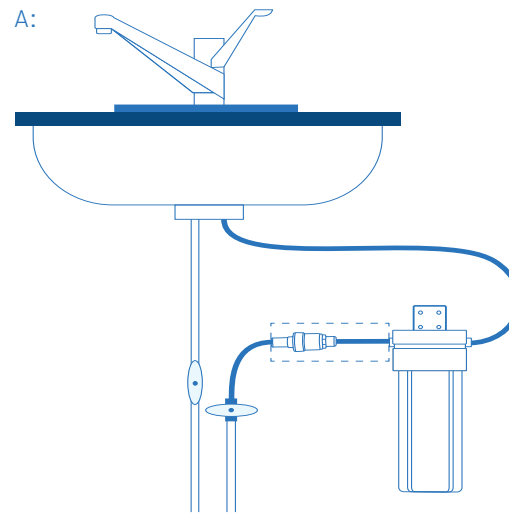

Start Up

1. Turn Cold water faucet shut off valve on slowly.
2. Open existing faucet slowly.
3. Allow trapped air and water to flow out of the faucet.
4. Allow water to flow for about 5 minutes to flush System before use.
5. Inspect fittings and installation to make sure there are no leaks
6. You are now ready for use.
7. We recommend periodic inspection of installation to be sure there are no leak or water conditions such as Water Hammer occurring as it may cause damage to your System.
Go to How To Clean and Replace Your Filter on page 14.

ProOne®/Coldstream Standard Under Counter System (Optional Faucet)

Package Contents

- (a) Filter housing
- (b) 3/8" quick connect push fittings attached
- (c*) ProOne®/Coldstream Filter (*Installed)
- (d) Separate faucet & hardware kit with connecting tube
- (e) Water Hammer Arrestor with connecting tube (optional). For use where the water condition known as "Water Hammer" may be present. Contact ProOne support at support@prooneusa.com to find out more about "Water Hammer"
- (f) T-valve (optional)
- (g) Mounting bracket (attached)

Specifications

Type of installation: Under Counter with Separate Faucet

Using optional separate faucet

Maximum Working Pressure:	75 psi (517 kpa)
Minimum Working Pressure:	10 psi (69 kpa)
Maximum Working Temperature:	38° C (110° F)
Minimum Working Temperature:	5° C (41° F)
Recommended Flow Rate:	0.2 – 1.0 gpm
Contaminant Reduction:	Refer to Lab Report
Standard Life Expectancy:	2600 gallons
Standard Replacement Filter:	POC-737RF

Tools & Hardware

The following tools & hardware may be required:

- Philips screw driver
- Plastic tube cutter
- 1/2" hole cutter or drill bit for countertop faucet
- 3/8" drill motor
- Adjustable wrench
- Teflon tape
- Safety glasses

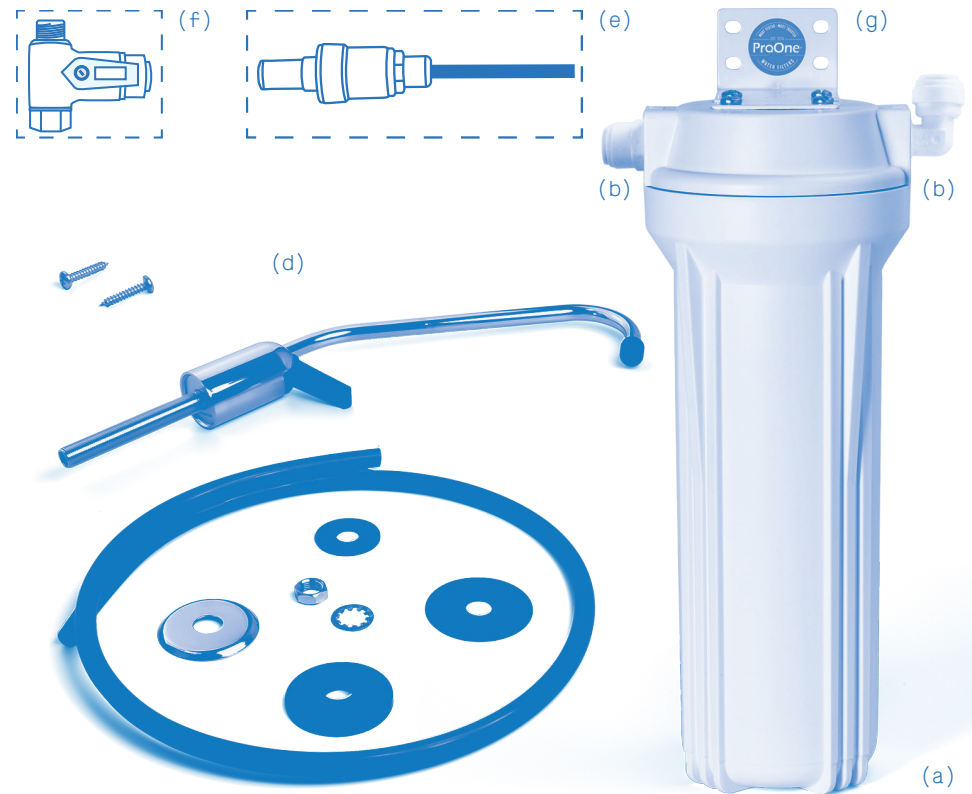

<p>⚠ Caution</p> <p>Before beginning the installation, turn OFF the cold water supply under your sink or your house water supply at the meter. Open the cold water faucet to release any water pressure.</p>	<p>⚠ Warning</p> <p>Use with cold potable water only. Do not use a water source that is microbiologically unsafe or of unknown quality without adequate disinfection before or after the system. For specific health requirements, consult your healthcare professional.</p>
---------------------------------------------------------------------------------------------------------------------------------------------------------------------------------------------------------------------	-------------------------------------------------------------------------------------------------------------------------------------------------------------------------------------------------------------------------------------------------------------------------------------

Installing Your Filter Housing

1. Select a suitable location for the filter housing(a) under the sink.

NOTE: location should be reasonably accessible for filter replacement. When mounting housing to cabinet, make sure to leave enough space below filter housing (min. 2 inches) for maintenance and filter replacement.

DO NOT INSTALL where temperatures fall below freezing as damage to the system will occur.

NOTE: The flow arrow and inlet/outlet are embossed on the top of the white plastic head.

2. Secure the mounting bracket(g) to the side of the sink cabinet in the desired location.

Connecting the System, T-Valve & Hammer Arrestor With Separate Faucet (optional)

1. Disconnect existing flex hose connected to your manual cold water shut off valve or cold water supply line.
2. Install the optional T-valve(f) as shown in the Diagram below. Configured for standard 3/8" fitting.
3. Reconnect existing flex hose to the outflow side of the T-valve. Other end of your flex hose should remain connected to the existing faucet.
4. Prepare a piece of 3/8" plastic tubing (included) to fit between the quick connect push fitting on the T-valve and the IN side on the water filter housing - ADD additional 1-1/2" to tubing length as tubing will travel about 3/4" into each fitting to seat properly.
5. When adding the optional Hammer Arrestor(e) device, insert the outflow tube of the Hammer Arrestor (with precut tubing - DO NOT ALTER the length of the outflow tube) into the INLET side of the water filter assembly.
6. Insert one end of plastic tubing into the quick connect on the T-valve - press in firmly.
7. With the other end of tubing, insert into the INLET side of the Hammer Arrestor if adding to your system, or the water filter assembly. Press in firmly.

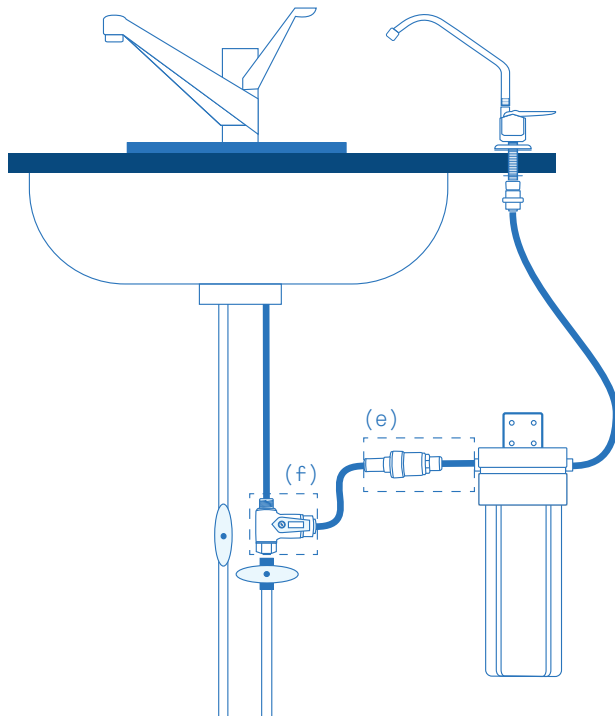

Installing the Faucet

1. Select a suitable location for the drinking water faucet as close to the sink as possible allowing convenient space under the sink for assembly. The spout of the faucet should be able to reach the sink. A 2" flat area is required to mount the faucet. Check for clearance then drill the sink top with a 1/2" bit to accommodate the faucet inlet pipe. We recommend you consult a qualified installer or plumber for drilling through your countertop.
2. Install the faucet through the sink top by:
 - a. Add the face plate(a) and large rubber washer(b) to the faucet stem.
 - b. Insert the faucet stem through the sink.
 - c. Place small rubber washer(c), plastic washer(d), star washer(e) and steel nut(f) onto the faucet stem. Tighten firmly with a wrench.
 - d. Attach the quick connect connector(g) to the threaded stem of the faucet using Teflon tape. DO NOT over tighten.

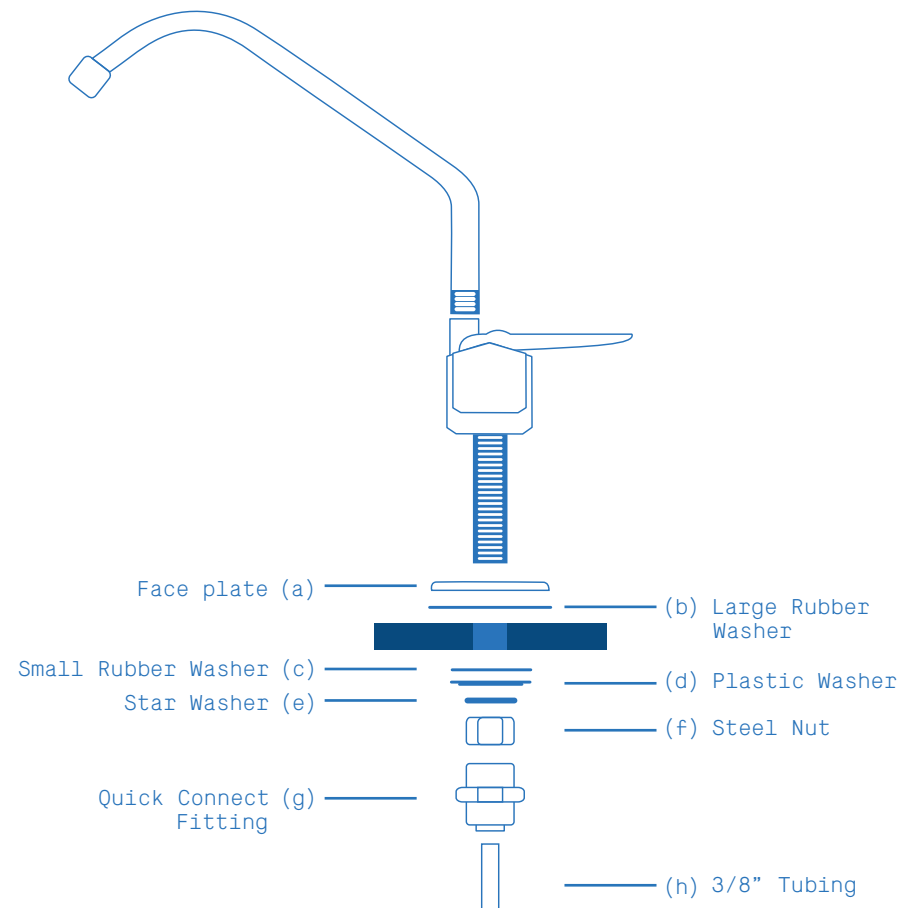

Installing the Connecting Tube

1. Prepare a piece of 3/8" included plastic tubing(h) to fit between the quick connect push fitting on the faucet and the OUTLET side on the water filter housing
2. ADD additional 1-1/2" to tubing length measurement as tubing will travel about 3/4" into each fitting to seat properly.
3. Insert end of plastic tubing into the quick connect push in fitting on the faucet. Press firmly.

Using the Faucet

1. Press down lever for on demand use or pull up lever for continuous use.

Start Up

1. Make sure T-valve is in the open position.
2. Open the faucet fully by lifting the black lever to its vertical position to allow trapped air and water to flow out of the System. Make sure the spout is positioned over the sink.
3. Slowly turn on your cold water supply valve under your sink or your house supply at the meter.
4. Water should start flowing out of the faucet. Look at the installation to make sure there is no water leaking from any of the fittings, tubing or housing.
5. Allow water to flow for about 5 minutes to flush out the system before using the water. Some residual particles may be expelled during the flush; this is normal.
6. Return black lever to off position.
7. Your system is now ready for use.

How to Clean & Replace Your Filter

CAUTION: Never remove the filter housing with water pressure in the System.

Your ProOne®/Coldstream filter element consists of 2 layers. The outer layer acts like a pre-sediment filter and is cleanable/reusable. Periodic cleaning is recommended but especially if you see a build up of discolored particulates on the outer blue surface of the filter element.

Once you scrub/clean through the blue layer and begin to see white, it's time to replace the filter element.

Removing Your Filter Element

Turn off the T-valve or supply line going to the System. Turn on the faucet to release any pressure.

Slowly unscrew the housing(a), which will be full of water, from the base. The ProOne®/Coldstream filter element(c*) can now be removed by gently pulling it away from the base.

Drain water from the filter housing over the sink and remove the filter element by gently pulling it out from the housing. Make sure the inside of the housing is clean. Wash housing with warm soapy water and rinse well.

Cleaning Your Filter Element

While holding the filter element under running water in one hand, use the dark green side of the scrubby sponge included and gently scrub the entire outer ceramic surface. You should see any residue build up slowly disappear as you scrub the filter element.

Rinse well after scrubbing.

Once cleaned, re-insert the filter element (the end cap of the filter element with the hole goes into the base) into the housing and securely tighten the filter housing back onto the base. Use the supplied wrench to tighten. DO NOT over tighten.

Replacing Your Filter

Insert end with hole side of the ProOne®/Coldstream Filter into the base of the filter system.

Please make sure that the washers on each end of the filter have been inserted correctly.

After the filter replacement has been installed, please go to Start Up as previously described in your system's section.

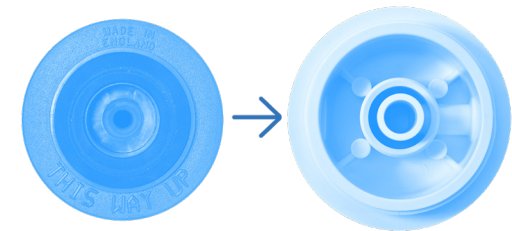

FAQs

How do I know when to replace my filter element?

- When the flow rate diminishes When you notice a change in taste or odor.
- When the inner, white layer of the ceramic shell of your filter element is visible.
- When you've filter the maximum amount according to your filter element's life expectancy.

What if I don't use the System for an extended period of time?

We recommend you drain your System and remove the filter element. When ready to use again, just reinstall and recondition the filter element before use.

How long will my filter element last before needing to be replaced?

The actual life expectancy of your filter element will vary depending on the specific chemistry and level of contaminants present in your water source but the filter element has an End Of Life Rating up to 2,600 gallons. Please visit the Independent Lab Report for details.

Most Tested. Most Trusted.



ProOne® Limited Warranty

Lincoln-Remi Group, LLC d/b/a ProOne® Water vvs("PO") sells its products with the intent that they are free from defects in materials and workmanship under normal use and care. PO provides a limited warranty to the original retail purchaser of ProOne® products ("Customer") of those ProOne® products described in this Limited Warranty when purchased from ProOne® or an authorized ProOne® dealer. PO will repair or replace any ProOne® product, at it's sole discretion during the warranty period under the following conditions:

1. Product Name: ProOne®/Coldstream Countertop and Mini Faucet Filter System. ProOne®/Coldstream Under Counter Filter System
2. If during two (2) years following the purchase of a ProOne®/Coldstream Countertop, Mini Faucet or Under Counter Filter System and one (1) year for the POC-737-RF replacement filter cartridge and 6 months for the POCM-737-RF replacement filter cartridge excluding the filter media, PO will replace or repair any component in this system when found to be defective by ProOne® during the warranty period.
3. No warranty is given as to the service life or performance of any filter media or any filter element because performance of ProOne® filters will vary with water conditions and water consumption. Customer is encouraged to visit the Lab Report Disclaimer under Terms and Conditions at www.prooneusa.com.
4. Any damage caused by misuse or abuse; accident; improper installation; dropped product; failure to follow recommended installation or provide recommended maintenance; transportation damage; neglect; environmental and water conditions including but not limited to water hammer; or any other conditions whatsoever that are beyond the control of PO are excluded from this warranty.
5. This express limited warranty is the sole and exclusive warranty.
6. ALL OTHER WARRANTIES, WHETHER EXPRESS OR IMPLIED, INCLUDING BUT NOT LIMITED TO, ANY IMPLIED WARRANTIES OF MERCHANTABILITY, FITNESS OR FITNESS FOR ANY PARTICULAR PURPOSE OR ANY OTHER POTENTIAL OBLIGATION ON THE PART OF PO WITH RESPECT TO PRODUCTS SOLD BY PO ARE DISCLAIMED. EXCEPT FOR ANY EXPRESS WARRANTIES, ALL ProOne® PRODUCTS ARE SOLD "AS-IS". PO shall not be held liable for any incidental, consequential or special damages of any sort whatsoever. The liability of PO is limited to the original retail purchaser and to the repair or replacement of defective components only during the Warranty Period. Labor charges incurred are not covered under this warranty. No refunds will be given at any time to anyone other than the original retail purchaser, except as provided in the refund policy of ProOne®. Please visit Refunds and Returns under Terms and Conditions at www.prooneusa.com The Customer is also encouraged to review the Lab Report Disclaimer under Terms and Conditions at www.prooneusa.com. The liability of PO terminates upon the expiration of the Warranty Period or transfer of product ownership.
7. To obtain warranty service on, or replacement of a ProOne® product, Customer should contact ProOne® customer service by email to support@prooneusa.com to confirm eligibility of warranty. Customer may be asked to send, . at the sole expense of the Customer: (a) the product including its original packaging; and (b) the dated sales receipt as proof of purchase, and a prepaid return package, to the following address:
support@prooneusa.com

[ProOne, 1200 Benstein Rd, Commerce Twp., MI 48390](mailto:support@prooneusa.com). NO C.O.D's will be accepted.

8. This warranty provides you with specific legal rights. You may have additional rights which may vary from country to country. Because of individual country laws and regulations, some of the above limitations and exclusions may not apply to you. For any warranty questions, please call 1-800-544-3533 or email to customerservice@prooneusa.com.

Attention CA, IA and WI Consumers. In compliance with states' law, ProOne products are sold and shipped to residents of these states without any health related performance claims except for aesthetics including chlorine reduction and improvement with taste, odor and sediment. Other states may apply.