

# OPERATING AND CARE INSTRUCTIONS

## VitaClay® Smart Organic Multi-Cooker

VM7900-8

VM7900-6Y

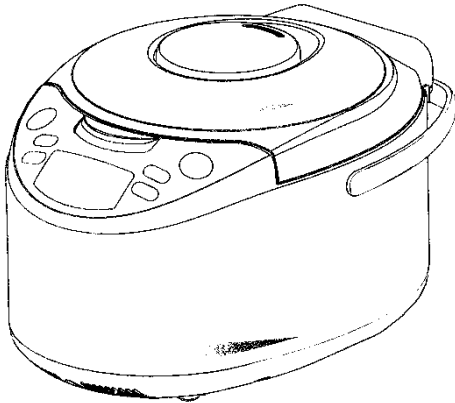

**READ ALL INSTRUCTIONS BEFORE INITIAL USE  
HOUSEHOLD USE ONLY**

© 2012 Essenergy, Inc. All rights reserved

## **IMPORTANT SAFETY INFORMATION**

**When using electrical appliances, basic electrical precautions should always be followed to reduce the risk of fire, electric shock and injury, including the following:**

- 1. Read all instructions before using the appliance.**
2. Do not operate any appliances that have damaged plugs or cords, malfunctioned or been damaged in any way. Return the appliance to the manufacturer or qualified service technician for repair or adjustment.
3. **Do not immerse** the heating unit of the appliance in water or any other liquid. To prevent electrical shock, do not place the cord, plug or cooking unit near water or other liquids.
4. Always unplug the cooker when not in use or before cleaning. Allow cooker to cool before cleaning or removing parts.
5. Do not touch hot surfaces; Use the handles or knobs provided.
6. **Avoid sudden temperature changes.** Clay is sensitive to changes in temperature, so allow it to cool and heat gradually. Placing a cold pot onto a hot surface or a hot pot in cold environment (such as a very cold countertop, the refrigerator or freezer) can cause the pot to crack. Also be sure that the outside of the pot is dry before placing inside the housing to cook.
7. Do not put cold liquids or food into heated pot. Thaw frozen foods before placing in heated pot unless warm liquid is already in pot. Do not immerse heated pot into cold water.
8. Do not place cooker on or near a hot gas or electric stove burner. Do not place cooker inside a hot oven or broiler.
9. Do not use outdoors.
10. Do not let cord hang over the edge of a table or countertop and do not let it touch heated surfaces.
11. Use **extreme care** when moving the cooker if it is filled with hot liquid.
12. Ensure cooker is always placed on a **flat, level surface** before use.
13. Closely supervise whenever cooker is being used by or near children.
14. Do not use this cooker for anything other than its intended use.
15. The use of accessory attachments not supplied or recommended by Essenergy may cause injury, fire or electrical shock and may also damage the cooker.
16. To disconnect, turn unit off and remove the plug from wall outlet by holding the plug. Do not pull the cord.
17. The clay pot is fragile. Be careful when carrying or storing.
18. Do not cook food directly in metal housing.
19. Do not start cooking function while the clay pot is empty.

20. Dry heat can cause the clay pot to crack or break. Always have some liquid present in the clay pot when the cooking cycle begins.
21. When using this appliance, provide adequate air space above and on all sides for air circulation. On surfaces where heat may cause a problem, an insulated heat pad is recommended.
22. When opening heated cooker, carefully lift and tilt cover away from you to avoid scalding and to allow condensed water to drip into pot. Steam and condensation will be very hot; be very careful not to burn.
23. **CAUTION:** To reduce the risk of electric shock, cook only in removable container.
24. To ensure continued protection against risk of electric shock, connect to properly grounded outlet only.
25. **SAVE THESE INSTRUCTIONS.**

This appliance is intended for **HOUSEHOLD USE ONLY**. There are no User Serviceable Parts inside. The heating unit needs no lubrication or other service. Do not attempt to service this appliance.

## **GROUNDING INSTRUCTIONS:**

This appliance must be grounded. It is equipped with a 3-wire detachable cord with grounded plug. The plug must be plugged into an outlet that is properly installed and grounded.

**WARNING:** Improper use of the grounded wire can result in a risk of electric shock. Consult a qualified electrician if necessary. Do not attempt to defeat this safety feature by modifying the plug.

The short power cord is provided to reduce the hazards resulting from entanglement or tripping over a long cord. An extension cord may be used with care.

If it is necessary to use an extension cord, it should be positioned so that it does not drape over the counter or tabletop where it can be pulled on by children or tripped over and:

- a) Use only 3-wire extension cord with 3-blade grounding plug.
- b) The marked rating of extension cord must be equal to or greater than the rating of this appliance. Electrical rating of this appliance. Electrical rating is listed on the bottom of this unit.

## **CLEAN UNIT THOROUGHLY BEFORE FIRST USE**

- Ensure the packing paper on the heating surface is removed.
- Wash the clay pot and lid with warm water and a small amount of detergent.
- Rinse and dry clay pot thoroughly before placing in the housing.

- Plug the power cord into the unit first and then plug into the wall outlet. When the cooker is ready for operation you will hear a long “beep”.
- Ensure the clock is set to the current time before using the Delay Timer key features (see Function Keys).

**Caution:**

1. A slight odor and/or smoke smell may be noticed during the initial use of this appliance. This is normal with many heating appliances and will disappear after the first few uses.
2. The cooker should be used for its intended purpose only and not for other cooking purposes such as stir frying, deep oil frying or rendering fat.
3. If liquids have been soaking in the clay pot for a long time, a leak could occur. Use a dry towel to dry the outside surface of the inner clay pot.
4. During the cooking process, the steam cap should always be in place for safety and performance.
5. Do not touch the steam cap during cooking process as it becomes very hot.
6. The clay pot and lid become very hot during the cooking process and/or when cooking is finished. Use a dry cloth to pick up the clay pot and use the enclosed lid lifter for the lid. Do not use bare hands.

## **CLAY POT CARING**

Unglazed natural clay promotes nourishing traditions, preserving all essential nutrients and vitamins in your foods. It creates excellent texture and intensifies foods' flavors. However,

- Like any ceramic material, clay pots should not be exposed to sudden temperature changes.
- The clay pot is considered a consumable part. For optimum cooking results, keep the clay pot in 'wet' cooking conditions to allow slow simmer and intensify flavors. Frequent dry heating clay pot causes stress that may lead to crack. To promote longevity of your cooker and clay pot, keep the pot in 'wet' cooking conditions—meaning water-based liquid should always be present in the clay pot during cooking.
- If the clay pot is preheated or is hot to the touch, do not add cold or frozen foods. Do not preheat or dry heat the clay pot. The clay pot should be at room temperature when adding hot or very cold ingredients.
- Do not add cold water if the pot is still hot.
- Thoroughly wash or sanitize the clay pot and let it dry completely before store your VitaClay® in a dry and clean environment.

PARTS ASSEMBLY ILLUSTRATION:

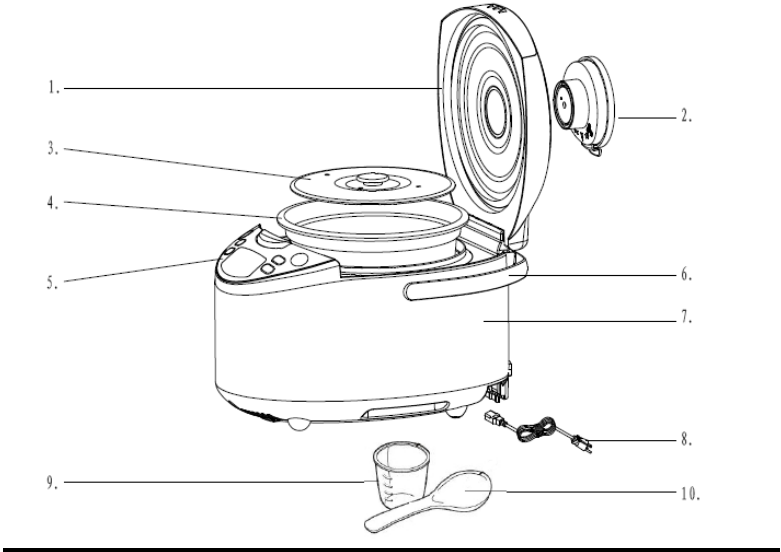

- (1) Cooker Cover
- (2) Steam Cap
- (3) Clay Lid
- (4) Clay Pot
- (5) Control Panel
- (6) Handle
- (7) Main Housing
- (8) Power Cord
- (9) Measuring Cup
- (10) Rice Spoon

# CONTROL PANEL DISPLAY AND FUNCTION KEYS



- (1) Delay Timer key
- (2) Hour & Minute keys: clock setting and/or slow cooking time duration setting
- (3) LCD rice cooking mode indicators (regular rice/brown rice/sweet rice/reheat)
- (4) Start/Cancel function key and indicator light
- (5) Rice Cooking selection key
- (6) Slow cooking selection key
- (7) remaining cook time indicator
- (8) Warm Time indicator
- (9) LCD Slow cooking mode indicators (Stew / Braise / porridge & Soup & Yogurt)

## **Function Keys**

### **Cooking with Delay Timer:**

- (a) Press the desired cooking key (“rice cooking” or “slow cooking”). If it is for “slow cooking”, press “Hour” or “Minute” key for desired cooking time; If it is for “rice cooking”, you do not need to set for cooking time as it is programmed to cook automatically.
- (b) Within a few seconds (while it is blinking), press “Delay” Timer key (1)
- (c) Using the “hour” and “minute” keys, set the screen the desired time ahead to begin cooking (If you want to start cooking one hour from

now, set to 1:00. To cook 3 hours and 30 minutes from now, set to 3:30)

- (d) Or Press START key, the LCD will automatically display the Delay time and will begin cooking at the desired time.

---

---

### **Rice Cooking Mode Indicators (3)**

---

---

Regular rice, Brown rice, Sweet rice, or Reheat rice

---

---

### **Start / Cancel Key (4)**

---

---

- (a) Press the key once, it starts cooking cycle after function key(s) is (are) selected.
- (b) Press the key again, it cancels the cooking cycle.

---

---

### **Rice Cooking Selection Key (5)**

---

---

Press for Rice Cooking selection to choose any of. White (rice or quinoa), Brown (rice), Sweet (rice) or Reheat (rice).

---

---

### **Slow Cooking Selection Key (6)**

---

---

Press for Slow Cooking Selection key, for any of following cooking functions: Stew/Braise/porridge or Soup or Yogurt

---

---

### **Clock and Time Left Indicator (7)**

---

---

- (a) Remaining cook time indicator (count down)
- (b) Time cooker has been on warm mode (count up)

---

---

### **Warm Time Indicator (8)**

---

---

Duration of warm time indicator.

---

---

### **LCD Warm Indicator (9)**

---

---

- (a) Indicator displays cooking cycle is at Warm.
- (b) The clay pot maintains a temperature between 70 °C to 75 °C (158 °F and 167 °F).
- (c) It automatically stays in WARM for 12 hours



## **USING THE RICE COOKER**

### **Rinsing Rice:**

To make great rice we recommend rinsing your plain, raw rice before cooking. If the rice is flavored or enriched, or the package clearly states not to rinse, however, doing so will wash away infused flavors. Try rinsing your plain rice in a strainer or bowl for best results.

The Rice Cooking Function Key (5) cycles between regular rice, brown rice, sweet rice and reheat rice options. Each option has a different micro computerized cooking mode which enables the cooker to determine the cook time automatically based on the rice option you choose. Cooking time setting is not required.

Assumed after rinsed the rice, we recommend water to rice ratios are:

- (a) For white rice (sushi rice, jasmine rice, etc.), place slightly over 1 part of water per part of rice, adjust the ratio as needed;
- (b) For sweet rice, place slightly less than 1 part of water per part of rice, adjust the ratio as needed;
- (c) For Brown rice, 1.5 part of water per part of brown rice, adjust the ratio as needed;
- (d) Ratio of water to quinoa is 2 part of water per part of quinoa. Choose on Regular (white) rice setting.

### **Note:**

1. If you decide not to rinse the rice, another quarter cup of water per cup of rice may need to be added.
2. To achieve the best cooking results, after the sound of the ‘beep’, let the rice stay on “Warm” mode for at least an additional 15 to 20 minutes. And then serve.
3. If you plan to keep the rice on WARM much longer than 30 minutes, we recommend adding a little more water to avoid the rice drying out on the bottom.

### **To start rice cooking immediately:**

- (a) Rinse rice thoroughly and place in the clay pot with the desired amount of water. Cover with clay lid.
- (b) Place the clay pot on the cooker’s heating element. Ensure the heating surface is clean: any particle interference could prevent the cooker from cooking evenly, can cause a burning smell and can even cause the pot to

crack. If there is food residue on the heating element, wipe with a damp cloth or magic eraser sponge until it is clean. Do not fill with or immerse in water.

- (c) Close the cooker cover. You will hear a “click” when it is snapped in. Plug cord into a 120V AC 60Hz only outlet.
  - (d) Press rice cooking function key (5) to select type of rice.
  - (e) Press “Start/cancel” key or within 7 seconds, the light indicator will turn on to indicate cooking cycle has started;
  - (e) A few minutes before cooking cycle completes, a “beep” will sound to indicate that the cooker will automatically switched to the “Keep Warm” state and then rice is ready to serve.
4. (d) For the best results, once rice is cooked, allow to remain on “warm” setting for 10-20 minutes before serving. It is then recommended to push the red “cancel” key to turn off the heat. If you plan to keep the rice in WARM mode much longer than 30 minutes, we recommend adding a little more water to avoid the rice drying out on the bottom. Rice or other food can be left in a closed cooker for several hours with no power and will stay warm, due to clay’s natural thermal retention.

### **To program rice cooking at the desired time clock:**

- (a) Repeat steps (a) to (c) above.
- (b) Press Delay Timer Function Key (1).
- (c) Make sure the clock is set at present time.
- (d) Press “Hour /Minute” function keys (2) until reached at desired cooking time.
- (e) Press Start / Cancel key, or within a few seconds, the LCD will display the pre-programmed time. The cooker will begin cooking at the desired time clock. A “beep” will sound to indicate cooking cycle has started and the cooking indicator light will turn on.
- (f) A few minutes before cooking is done, a “beep” will sound to indicate that the cooker has automatically switched to “Warm” mode and the Warm/Cancel light will turn on. Once the cooker enters the Warm mode, the rice is ready to serve.

### **Brown Rice and Quick Serving Tips**

A whole grain of rice has several layers, but only the outermost layer (the hull) is removed to produce what we call brown rice. This process is the least damaging



to the nutritional value of the rice and avoids the unnecessary loss of nutrients that occurs with further processing.

- Rinse brown rice at least three times in cold water.
- Stir with hands in a circular motion
- Drain and place into clay pot
- Follow instructions for “Using the Rice Cooker”

Cook the brown rice in mushroom or vegetable stock, leftover vegetable-steaming water or with your favorite herbs. Other variations are to add cashews, cranberries, raisins, apple chunks, mango cubes, mushrooms, garlic and onions. Sauté these ingredients in olive oil and mix into the prepared rice. Cooking the rice in mushroom stock and then mixing it with mushrooms makes a flavorful dish.

You can turn any rice dish bright yellow by adding a few dashes of turmeric. This doesn't change the flavor, just the color.

### **Reheating Cold Rice**

Previously cooked rice can be reheated in the cooker. If the clay pot has been in the refrigerator, be sure to allow it to return to room temperature. Use a spoon or spatula to scoop the rice away from the bottom of the pot. Then place the pot inside the housing with the previously cooked rice, add a few tablespoons of water, cover, and select the “reheat rice” option. Break up the cold rice in the clay pot and add hot water as desired to speed up reheating process.

### **Quick Serving Ideas**

- (1) Heat cooked rice with milk. Add in cinnamon, nutmeg, raisins and honey for a delicious rice pudding.
- (2) Make homemade vegetable sushi rolls by wrapping brown rice and your favorite vegetables in sheets of well moistened nori.
- (3) Use rice leftovers for cold rice salads: great for on-the-go lunches. Be creative and add in chicken or tofu with your favorite vegetables, nuts, herbs and spices.
- (4) Serve beans and rice accompanied by the vegetables of your choice for a simple yet delicious lunch or dinner entrée.
- (5) Rice as a side dish need not be served plain - spruce it up with the toppings of your choice. Some favorites include nuts, sesame seeds, sautéed mushrooms and scallions.
- (6) Place rice and chopped vegetables in pita bread, top with your favorite dressing and enjoy a quick and easy lunch.

## **USING THE SLOW COOKER**

The VitaClay® preserves nutrients allowing food to cook in its natural juices. It brings food to a boil 2-4 times faster than conventional slow cookers then reduces the heat to a slow simmer for gourmet perfection. The Automatic Warming Cycle holds food perfectly cooked for up to 12 hours. It reduces the cooking time by 30-50%. It also reduces the cooking liquid by 7 - 8% of the original amount per cooking hour in addition to adequate liquid requirements by each specific type of food. ***Suggestion for initial use: test frequently to see if the contents are covered with the cooking liquid during cooking, then come to your own decision on the duration of cooking and amount of liquid desired.***

To convert cooking time from conventional slow cooker recipes into VitaClay® slow cooking: the rule of thumb is if the conventional slow cooking time is set on 'high' for 4 hours, or on 'low' for 8 hours, the VitaClay® will only take 2 hours. Most dishes will require no longer than 2 hours to fully cook.

### **To start the slow cooker immediately:**

- (a) Place recipe contents in the clay pot and cover with the lid.
- (b) Place the clay pot on the cooker's heating base. Ensure there is no particle interference to prevent the cooker from cooking evenly.
- (c) Close the cooker cover. You will hear a "click" when it is snapped in. Plug cord into a 120V AC 60Hz only outlet.
- (d) Press the slow cooker function key (6) to select desired function cycle. When the "default" cooking time indicator flashes, enter the desired cooking time by pressing "Minute" or "Hour" key while it is flashing.
- (e) Press "Start/cancel" key or within 7 seconds, the slow cooker will "beep," start to heat up and the indicator light will illuminate. When the Slow Cooker reaches the desired cooking time, the system will indicate cooking is complete and will automatically switch to "Warm." The LCD will display the warm time duration.

Note:

1. To steam veggies or fish, place 2 to 4 cups of water in VitaClay, then place veggies inside a steam tray or bowl; press "Slow cooking" key, followed by pressing "minute" key for 30 minutes, continue pressing "Hour" key until "0" hour, press "Start/Cancel" key to start steam.

### **Caution:**

1. To prevent overflow: do not fill the cooker more than  $\frac{3}{4}$  full of water.
2. Ensure all ingredients are fully cooked before serving. If not, re-program to cook longer.

3. If the Stew/Soup cycle is too thick and causes the cooker to overheat, the cooker will give a warning “beep” and switch to the Warm cycle. You can cancel the operation by pressing the Warm/Cancel function key (4).
4. Do not add any liquid to a hot clay pot, as it can crack the clay pot or lid.
5. Do not place clay pot or lid on cold surface.

### **To program slow cooker to cook at the desired time clock:**

- (a) Make sure the clock is set at present time.
- (b) Repeat steps (a) to (d) above.
- (c) Press Delay timer function key (1).
- (d) Select “Hour”/“Minute” function keys (2) to the desired time to cook.
- (g) Press “Start/Cancel” key, or within 7 seconds, the LCD will display the pre-programmed time. The cooker will begin cooking at the desired time clock. A “beep” will sound to indicate cooking cycle has started and the cooking indicator light will turn on.

**Recommendations:** When making porridges/oatmeal, (1) set minimum cooking time to prevent from burning or sticking to the bottom (normally around 20 minutes); (2) let cooker cover open during cooking to prevent overflow; (3) Do not add any cold or hot liquid during cooking that may cause clay pot crack. Approximate 2-3 cups water per cup oatmeal.

## **CARE AND CLEANING**

- Like any ceramic material, clay pots should not be exposed to sudden temperature changes.
- The clay pot is considered a consumable part. For optimum cooking results, keep the clay pot in ‘wet’ cooking conditions to allow slow simmer and intensify flavors. Frequent dry heating of the clay pot causes stress that may lead to a crack. To promote longevity of your cooker and clay pot, keep the pot in ‘wet’ cooking condition—meaning to always have some water-based liquid present in the pot when cooking.
- If the clay pot is preheated or is hot to the touch, do not add cold or frozen foods. Do not preheat or dry heat the clay pot. The clay pot should be at room temperature when adding hot or cold ingredients.
- Do not use cold water if the pot is still hot.
- Thoroughly wash or sanitize the clay pot and let it dry completely before storing your VitaClay® in a dry and clean environment.

- For general washing, wait until the clay pot cools. Then wash it in warm water with a very small amount of natural dishwashing liquid and rinse thoroughly.
- Do not use abrasive scouring powders or steel wool. Plastic brush or nylon scrub pads can be used as needed.
- For hard to remove residue or burns, or to do a thorough cleaning, boil water with several spoonfuls of baking soda in the clay pot for 1-2 hours (make sure the water doesn't boil away completely).
- After washing, dry thoroughly and store. Always clean and dry thoroughly before storing.
- If the cooker should become moldy (because it was not thoroughly cleaned or food residue was left inside), make a paste of baking soda and water, cover the cooker with the paste and allow it to dry. When the paste is dry, rinse with water and dry well.
- If clay pot pores become clogged, boil the pot to remove debris. Use a roaster with a rack and add tepid water. Place the pot bottom on the rack and bring water to a boil. Boil for 30 minutes to remove the debris. Repeat doing the top if necessary.
- Some cooking residue may fill into the venting holes of the clay lid itself, or around the clay lid. To clean, use a warm water to wash the clay lid, and use damp cloth to wipe silicon vent gasket and the large silicone ring (being careful not to remove it).

**Caution:** When washing the clay pot, it is recommended that a soft cloth or pad be placed between the pot and sink to protect the pot from hitting the sink.

### **A remedy to remove burnt food from the bottom of the pot-**

*Put 1 cup water, 1/4 vinegar, 1 TP of baking soda and turned the cooker on the Slow cooking – Stew setting and let it on for 20 minutes. If you need to boil it for 40 minutes, you need to double the ingredients, specially water to prevent from dry heating that causes stress on clay pot.*

### **CLEANING OUTSIDE OF COOKER UNIT**

The outside of the cooker may be wiped clean with a soft cloth and warm soapy water. Wipe dry. Do not use abrasive cleaners. Grease may be removed with diluted ammonia. Do not let the Control Panel or any electrical mechanisms within the unit get wet.

### **CLEANING INSIDE OF COOKER UNIT**

If an object becomes stuck to the heat element lightly rub it off using a fine sandpaper #600 or steel wool. Then wipe with a damp cloth.

## How to Operate the New VitaClay® Yogurt Maker Option

Ever wanted to make your own yogurt but thought it would be too hard? It couldn't be easier with the new yogurt maker built right into your new VitaClay® multicooker!

1. Place 32 oz to 48 oz of fresh, pasteurized milk into a high-sided sauce pan (1 cup of milk makes about a cup of yogurt).
2. Heat the milk until it just starts frothing (but before it boils) or measure it: use a cooking thermometer and watch until it is heated to **180°F (82°C)**. Remove the saucepan from heat and allow the milk to cool to lukewarm. To accelerate the cooling down, place the saucepan in cold water.
3. When the temperature reaches **110°F (43°C)**, you may add your yogurt culture. Culture may either be bought freeze-dried or you can use plain yogurt from the store or a previous homemade batch. If not using a thermometer, wait until the pot is just cool enough to touch with your bare hands (still very warm). Pour the milk into a small clean cup and add 2-3 Tablespoons of plain yogurt then stir culture in to distribute it evenly. Mix the room temperature milk well with the smooth mixture and pour into VitaClay pot.
4. Place the clay pot into the VitaClay cooker and push the "Yogurt" button. Set it for 6 to 8 hours. Wait for the beep and it will begin the incubation. Place the clay lid on the pot and close up the cooker.
5. Once the yogurt is done, dispense the yogurt into your own containers or leave in the clay pot to refrigerate for 4 hours before using. Store in the refrigerator and use within 4-5 days.
6. Greek yogurt: The yogurt will thicken further in refrigerator. After more whey separates from the yogurt, it will become creamy Greek yogurt or yogurt cheese. You might use a strainer or cheese cloth to separate more of the whey from the yogurt. This will help thicken more.
7. Feel free to flavor with fruit, honey or vanilla beans and enjoy!
8. Don't forget to save a small amount to make the next batch!

### Note:

1. 6 to 8 hours is best. The longer the yogurt coagulates beyond that time, the sourer the taste becomes.
2. Water may condense on the lid of the cooker. When you remove the lid, take care not to drip any accumulated water into the finished yogurt.
3. Mark the date you made the yogurt or with the date the yogurt will expire (10 days). Chill them in the refrigerator for a minimum of three hours before eating.

4. THE YOGURT MAKER SHOULD REMAIN PERFECTLY STILL DURING THE MATURING PROCESS. DO NOT REMOVE THE APPLIACNE AS THIS WILL AFFECT THE FIRMNESS OF THE YOGURT.

## **CHOOSING THE MILK**

The following types of milk may be used: Pasteurized milk of any fat content (full, 2%, 1% or fat-free), Powdered milk, Long-life UHT sterilized milk, Soy milk. Be sure to use UHT soy milk which contains one of the following ingredients: fructose, honey or malt. These ingredients are necessary for fermentation and you will not succeed if none are available in the milk.

Fresh milk must be boiled and, if necessary, filtered before the use. The taste and texture of the yogurt varies according to the milk and yogurt starter selected.

## **UNFLAVORED YOGURT**

The taste and texture of the yogurt varies according to the milk and yogurt starter selected. You should experiment with milk of various fat contents to determine which one you prefer.

## **YOGURT FLAVORED AFTER COOKING**

You may choose to make flavored yogurt and add sugar, honey, flavorings, fruit or other ingredients to taste just prior to eating.

## **YOGURT FLAVORED WITH JAM AND JELLY, (OR HONEY, OR SYRUP)**

Ingredients:

- 4-5 tablespoons of jam and jelly, (or honey or syrup)
- 5 tablespoon of unflavored yogurt or 1 tablespoon of culture
- 32 oz of milk

Heat the milk until it boils (82°C-180°F), for 1-2 minutes and starts to climb the sides of the saucepan. Remove the saucepan from heat and allow the milk to cool lukewarm (43°C-110°F). To accelerate the cooling down, place the saucepan in cold water. Warm the jam and jelly (or honey or syrup) over low heat. Add half of the milk and stir until smooth; let cool again to (43°C-110°F), stir together the culture, jam or jelly and remaining milk until smooth. Add the jam or jelly (or or honey or syrup) while stirring. Add the mixture in VitaClay cooker. Cover the cooker. Set “Yogurt” for 6 hours.

## **YOGURT FLAVORED WITH FRESH FRUIT**



### Ingredients:

- ½ cup chopped fresh fruit
- 4 tablespoons of sugars or to taste
- 1-3 cup water
- 5 tablespoons of unflavored yogurt or 1 tablespoon of culture
- 32 oz of milk

Heat the milk until it boils (82°C-180°F), for 1-2 minutes and starts to climb the sides of the saucepan. Remove the saucepan from heat and allow the milk to cool lukewarm (43°C-110°F). To accelerate the cooling down, place the saucepan in cold water. Cook the fruit in the sugar and water over low heat for 10-15 minutes or until thickened. Let cool again to (43°C-110°F). Stir together the culture and milk until smooth. Stir in the chopped fruit. Add the mixture in VitaClay cooker. Cover the cooker. Set “Yogurt” for 6 hours.



# LIMITED ONE-YEAR WARRANTY

## On-Line warranty registration

[www.vitaclaychef.com](http://www.vitaclaychef.com)

Essenergy, Inc. (“Essenergy”) warrants this Product against defects in material or workmanship for a period of one (1) year from the date of original purchase, when utilized for normal household use. Essenergy will repair or replace the Product, at its option, at no charge except for shipping and handling.

This warranty does not cover: (1) The clay pot or lid; (2) damage due to incorrect customer instruction, installation or set up; (3) cosmetic damage or other damage due to an act of God, accident, misuse, abuse, or negligence; (4) commercial use of the Product; (5) modification of any part of the Product; (6) damage due to improper operation, improper maintenance, or connection to an improper voltage supply; (7) damage due to attempted repair of the Product by anyone not authorized by Essenergy to service the Product; (8) normal wear of parts; (9) Damage or defects caused by shipping, faulty packaging or mishandling in transit; (10) any non-electric/mechanical attachments and accessories and disposable parts including measuring cup, spoon, inner pot, outside case, cord and plug.

**KEEP YOUR SALES RECEIPT.** Warranty service will require presentation of proof of purchase in the form of a bill of sale or receipt which shows the date of purchase and establishes that the Product is within the warranty period.

**PLEASE REGISTER YOUR PRODUCT WITHIN 10 DAYS OF PURCHASE.** Product must be registered in order to claim warranty service. Please visit [www.VitaClayChef.com](http://www.VitaClayChef.com) to register your product. If you need a registration form, please contact [service@essenergy.com](mailto:service@essenergy.com) or call us toll-free at 1-877-877-9121.

This warranty is invalid if the factory applied serial number or production date has been altered or removed from the Product.

To obtain warranty service, first contact customer service to receive an RMA number. You will receive instructions for the return of your unit once it has been authorized. You will need to send the complete electronic housing (**without the clay pot or lid**) insured, freight prepaid, plus proof of purchase (as described above). Be sure to package in the original packaging and ensure the machine is secure inside of the box, with no rattling or movement once the box is sealed. If the unit arrives with damage from shipment, the warranty will be invalidated.

Please attach your name, address, telephone number, and a description of the problem along with return postage. A warranty form should be completed and

included with the package. The product must be sent carefully packed and properly cushioned to prevent damage in transit. Your failure to abide by these provisions may cause your request for warranty service to be denied, and the repaired unit will be returned at your expense. This warranty is extended only to the original purchaser of this product and does not extend to any commercial use or unreasonable use. This warranty is valid only in the United States.

NOTE: REPAIR OR REPLACEMENT AS PROVIDED UNDER THIS WARRANTY IS THE EXCLUSIVE REMEDY OF THE CONSUMER. ESSENERGY SHALL NOT BE LIABLE FOR ANY INCIDENTAL OR CONSEQUENTIAL DAMAGES FOR BREACH OF ANY EXPRESS OR IMPLIED WARRANTY ON THIS PRODUCT EXCEPT TO THE EXTENT PROHIBITED BY APPLICABLE LAW. ANY IMPLIED WARRANTY OF MERCHANTABILITY OR FITNESS FOR A PARTICULAR PURPOSE ON THIS PRODUCT IS LIMITED IN DURATION TO THE DURATION OF THIS WARRANTY.

Some states do not allow the exclusion or limitation of incidental or consequential damages, or allow limitations on how long an implied warranty lasts, so the above limitations or exclusions may not apply to you. This warranty gives you specific legal rights, and you may have other rights which vary from state to state.

**Essenergy, Inc.**  
**[www.VitaClayChef.com](http://www.VitaClayChef.com)**  
**(408) 329-7392 (Customer support)**  
**Made in China**

Revision: 9/2017