



TAC
1354 Clifford Avenue
P. O. Box 2940
Loves Park, IL 61132-2940
www.tac.com

MK-2690

***Pneumatic Valve Actuator
General Instructions***

Application

For proportional pneumatic control of 1/2" to 1-1/4" VB-111 and VB-9xxx series valves.

Features

- Compact size with 6 in.² (39 cm²) effective area.
- Rugged die cast aluminum housing.
- Replaceable beaded molded neoprene diaphragm.



Applicable Literature

- Environmental Controls Cross-Reference Guide
F-23638
- Environmental Controls Reference Manual
F-21683
- Environmental Controls Application Manual
F-21335
- AV-400 Valve Linkage — General Instructions
F-19073

SPECIFICATIONS

Actuator Inputs

Compatible With: Proportional pneumatic signal. See Table-1.
Start Point, Non-adjustable.
Air Connections: 1/8" FNPT located on side of housing.

Actuator Outputs

Mechanical:
Stroke, 1/2" (12.6 mm) nominal.

Environment

Ambient Temperature Limits:
Shipping, -40 to 220° F (-40 to 104° C).
Operating, -20 to 220° F (-29 to 104° C).
Humidity: 5 to 95% RH, non-condensing.
Location: NEMA Type 1 indoor only.
Maximum Air Pressure: 30 psig (207 kPa).
Spring: Retracts actuator shaft and raises valve stem on loss of air pressure.
Springs provided in AV-400 linkage (order separately).

Table-1 Spring Ranges.

Actuator Part Number	Nominal Spring Range* (Spring Color Code)	
	psig	kPa
MK-2690	3 to 7 (Yellow)	21 to 48
	5 to 10 (Black)	34 to 69
	8 to 13 (Blue)	55 to 90

*Nominal (no load) condition, spring ranges based on 1/2" (13 mm) maximum stroke, provided by AV-400 linkage (order separately).

ACCESSORIES

AK-42309-500 Positive positioner and linkage;
use with MK-2690-0-0-1 or MK-2690-0-0-2 models only
AV-400 Valve linkage

TOOLS

TOOL-95-1 Pneumatic calibration tool kit

MAINTENANCE PARTS

PNV-102 Diaphragm

INSTALLATION

Inspection

Inspect the package for damage. If damaged, notify the appropriate carrier immediately. If undamaged, open the package and inspect the device for obvious damage. Return damaged products.

Requirements

- Job piping diagrams
- Tools (not provided):
 - 1-5/8" open-ended wrench
 - Appropriate screwdriver
- Training: Installer must be a qualified, experienced technician

CAUTION

- Make all connections in accordance with the piping diagram.
 - Do not exceed ratings of the device(s).
 - Avoid locations where excessive moisture, corrosive fumes, or vibration is present.
-

Mounting

The MK-2690 is generally installed in an upright position. When connecting to the control air line the actuator may be swiveled to any convenient position above the center line of the valve body.

NOTE

The actuator should be removed from the valve body during valve installation.

Installing Actuator on Valve Body

1. Position actuator assembly over valve stem and spring and secure with mounting nut. (See Figure-1.)
2. Swivel actuator to convenient position for piping.
3. Connect air supply to actuator.

For information on valve linkage assembly, see General Instructions for AV-400 linkage (F-19073).

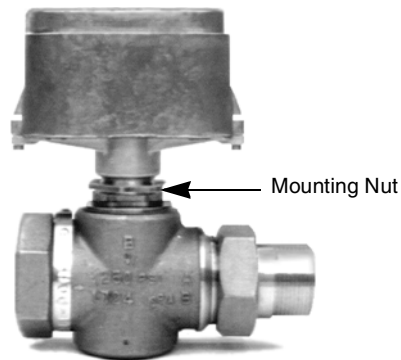

Figure-1 Actuator Assembled to Valve Body with Linkage.

Removing Actuator from Valve Body

1. Loosen mounting nut. (See Figure-1.)
2. Lift actuator straight up until it clears the valve spring.

NOTE

When removing the actuator, make sure that the piston is not pulled out of the diaphragm.

3. Lay the actuator on its top until it is to be installed.

MAINTENANCE

Regular maintenance of the total system is recommended to assure sustained optimum performance.

FIELD REPAIR

Replacing Actuator Diaphragm

1. Disconnect air supply to actuator.
2. Loosen mounting nut. (See Figure-3.)
3. Lift the actuator off the valve body and linkage.
4. Place actuator on its top, and remove two (2) lower housing screws. Remove lower housing.
5. Remove piston from actuator.
6. Turn actuator housing over and remove the diaphragm retaining screws.
7. Remove diaphragm and its retainer from actuator housing by pulling them straight out from housing. (See Figure-2 and Figure-3.)
8. Remove diaphragm retainer from old diaphragm and install new diaphragm.
9. Place diaphragm and retainer in housing and secure with two screws.
10. Place the actuator housing on its top (open side up) and center the piston on the diaphragm. (See Figure-2.)
11. Pull protrusions on diaphragm through mating holes on piston. (See Figure-2.)
12. Push the piston down evenly, rolling diaphragm around piston. Be certain to position the piston squarely on diaphragm with equal distances from piston to housing sides. (See Figure-2.)
13. Install lower housing to the actuator housing with two retaining screws.
14. The actuator is now assembled. (See Figure-1.)
15. Install actuator on valve body.

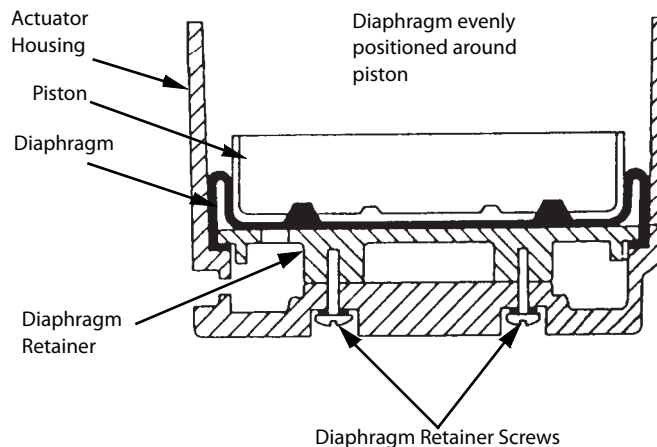

Figure-2 Positioning Piston in Diaphragm
(shown with actuator in the inverted position).

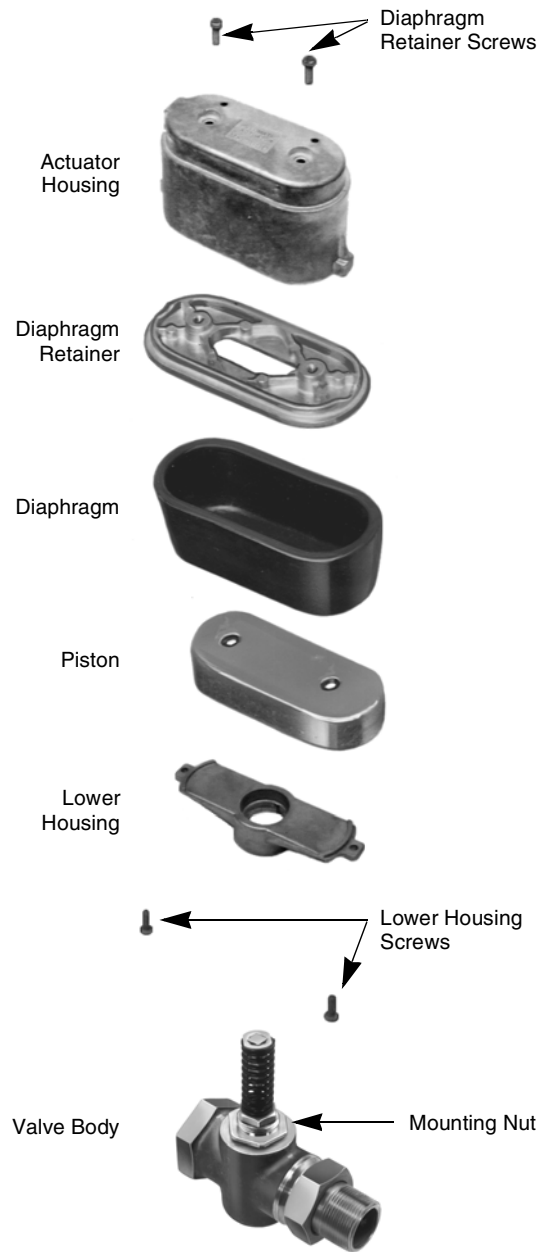

Figure-3 Exploded View of MK-2690.

DIMENSIONAL DATA

All dimensions in inches (millimeters in brackets). See Figure-4.

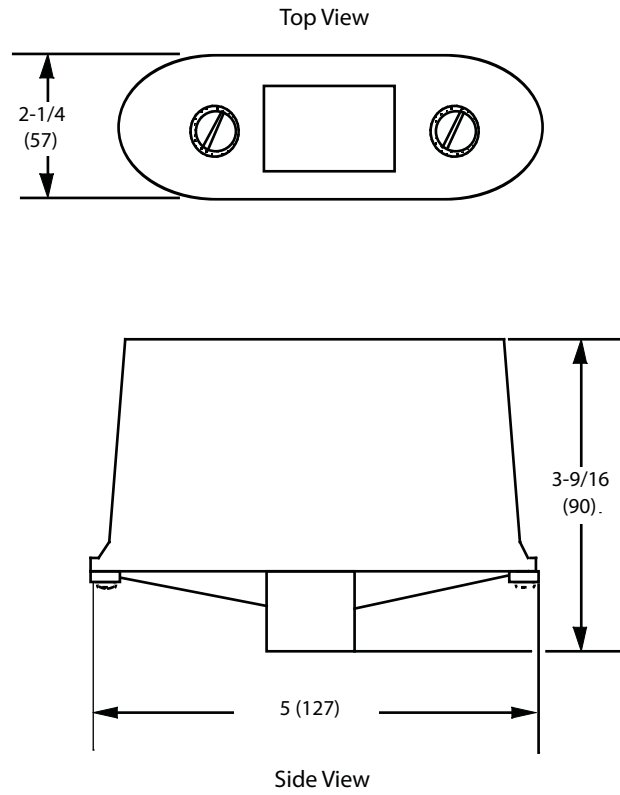

Figure-4 MK-2690 Pneumatic Actuator.

Copyright 2006, TAC
All brand names, trademarks and registered
trademarks are the property of their respective
owners. Information contained within this
document is subject to change without notice.

TAC
1354 Clifford Avenue
P.O. Box 2940
Loves Park, IL 61132-2940

F-13893-5



www.tac.com

