

DISCLAIMER OF WARRANTY

This motorcycle is sold "as is" with all faults, obvious or not. There are no warranties expressed or implied, including any warranty of merchantability and warranty of fitness for any particular purpose.

"WARNING"

THE COBRA CX50FWE (KING) IS A COMPETITION MODEL ONLY AND IS **NOT** MANUFACTURED FOR, NOR SHOULD IT BE USED ON PUBLIC STREETS, ROADS OR HIGHWAYS.

THE USE OF THIS BIKE SHOULD BE LIMITED TO PARTICIPATION IN SANCTIONED COMPETITION EVENTS UPON A CLOSED COURSE BY A SUFFICIENTLY SKILLED RIDER AND SHOULD NOT BE USED FOR GENERAL OFF-ROAD RECREATIONAL RIDING.

IMPROPER USE OF THIS MOTORCYCLE CAN CAUSE INJURY OR DEATH.

THIS BIKE IS INTENDED FOR EXPERIENCED RACERS ONLY AND NOT FOR BEGINNERS.

IT IS YOUR RESPONSIBILITY AS THE OWNER OF THIS COBRA MOTORCYCLE OR AS THE PARENT, OR LEGAL GUARDIAN OF THE OPERATOR, TO KEEP THIS COBRA MOTORCYCLE IN PROPER OPERATING CONDITION.

THIS BIKE WAS DESIGNED FOR RIDERS THAT WEIGH LESS THAN 80 LBS WITH FULL RIDING GEAR AND SHOULD NOT BE OPERATED BY RIDERS THAT WEIGH MORE THAN THAT.

BE SURE THAT THE RIDER ALWAYS WEARS ADEQUATE SAFETY GEAR EVERYTIME HE OR SHE RIDES THEIR COBRA MOTORCYCLE.

IMPORTANT SAFETY NOTICE

WARNING

Failure to follow WARNING instructions could result in severe injury or death to the machine operator, a bystander, or a person inspecting or repairing the machine.

CAUTION:

A CAUTION indicates special precautions that must be taken to avoid damage to the machine.

NOTE: A NOTE provides key information to make procedures easier or clearer.



Table of Contents

GENERAL INFORMATION	4
SPECIFICATIONS - GENERAL	4
OPTIONAL SUSPENSION COMPONENTS	5
SPECIFICATIONS - TORQUE VALUES	5
BREAK-IN PROCEDURE	6
STARTING PROCEDURE	7
MAINTENANCE	8
TIPS	8
SCHEDULE	9
REPLACING TRANSMISSION / CLUTCH LUBRICANT	10
PROPER CHAIN ADJUSTMENT	11
REAR BRAKE MAINTENANCE	12
BRAKE BLEEDING PROCEDURE	13
AIR FILTER CLEANING	14
FORK MAINTENANCE	15
Fork Air Bleeding	16
Fork Oil Replacement	16
FRICTIONAL DRIVE (V3 CFD)	17
PARTS – AIRBOX & INLET SYSTEM	19
PARTS – BARS AND CONTROLS	20
PARTS – CARBURETOR	21
PARTS – COOLANT SYSTEM	22
PARTS – ELECTRICAL SYSTEM	23
PARTS – ENGINE – BOTTOM END AND TRANSMISSION	24
PARTS – ENGINE CLUTCH AND KICK LEVER	26
PARTS – ENGINE – WATER PUMP	28
PARTS – ENGINE – TOP END	29
PARTS – EXHAUST SYSTEM	30
PARTS – FORKS & TRIPLE CLAMPS	32
PARTS – FORKS – LEG ASSEMBLY – BRAKE SIDE	34
PARTS – FORKS – LEG ASSEMBLY – NON-BRAKE SIDE	36
PARTS – FRAME I	38
PARTS – FRAME II	39
PARTS – FRONT BRAKES	40
PARTS – FRONT WHEEL	41
PARTS – PLASTIC BODYWORK & SEAT	42
PARTS – REAR BRAKE	43

PARTS – REAR WHEEL	44
PARTS – SHOCK	45
PARTS – SHOCK - INSIDE.....	46
PARTS – SWINGARM ASSEMBLY	47
SERVICE	48
ENGINE SERVICE	48
Base Gasket Selection	49
Engine Removal.....	51
Complete Engine Disassembly Procedure	52
Top End Disassembly Procedure.....	53
Splitting the Cases.....	54
Engine assembly.....	54
CLUTCH.....	56
CLUTCH ASSEMBLY:	59
IGNITION	60
COOLING SYSTEM.....	62
FUEL & AIR SYSTEM	64
Carburetor:.....	64
Reeds:.....	66
EXHAUST	66
REAR WHEEL PULLERS	66
BRAKES	67
FRONT FORKS.....	67
REAR SHOCK	67
TUNING	68
CLUTCH.....	68
GEARING	71
SUSPENSION	73
Adjustment.....	73
Front Fork Operation	74
Fork Damping Adjustments	74
Rear Shock Adjustments	75
CARBURETION	76
TROUBLESHOOTING.....	79

General Information

Specifications - General

Items	CX50 FWE
Dimensions Wheelbase Wheel size Seat height	39" (991mm) 10" (254mm) rear, 12" (305mm) front 26" (660mm)
Engine Type Cooling system Coolant Displacement Bore and stroke Ignition system Spark plug Gap Ignition timing Fuel type Premix Oil type Premix oil ratio after break-in Carburetion Slow (Pilot) Jet / Main Jet Float Height	2-stroke, single cylinder, reed valve Liquid-cooled Liquid Performance Mini Coolant  49.8 cc 39 mm x 41.7 mm PVL Analogic Autolite – XS61 & 4261  0.023" – 0.025" (0.58 – 0.64 mm) 0.035" (0.9 mm) Before Top Dead Center (BTDC) High octane <i>pump</i> gasoline <i>Bel-Ray H1-R</i>  40:1 to 50:1 19 mm Dell'Orto 60 / 96 16mm \pm 0.5mm (0.63" \pm 0.020")
Transmission Speed Final drive ratio Chain Transmission / clutch oil type Quantity	Single 14/37 T 100 links 420 <i>Cobra Venom 3 Shoe Clutch Milk</i> 250ml (8oz)
Chassis Front tire Pressure Rear tire Pressure Front fork Fork oil type Fork oil amount Std settings Rear shock (std. settings)	2.50 (60/100) - 12" 16 psi minimum 2.75 (80/100) - 10" 16 psi min. (20 psi for hard pack or rocky conditions) CARD 32mm USD Fully Adjustable w/ Smart Leg 2.5wt Bel-Ray Fork Oil 155 ml Smart leg: 1.5 out, Compression and rebound 2 out Compression: Low 12 out, High 15 out Rebound 16 out, Race sag 75mm

Optional Suspension Components

Weight of Rider (lb)	Fork Spring	Shock Spring
Less than 50 lb	0.23 kg/mm KCCS3223	red, 3.3 kg/mm SCKGFX33
50 – 60	0.23 kg/mm KCCS3223	gray, 3.5 kg/mm SCKGFX35
60-75	0.25 kg/mm KCCS3225	yellow, 3.7 kg/mm SCKGFX37
Greater than 80	0.27 kg/mm KCCS3227	gold, 3.9 kg/mm SCKGFX39

Specifications - Torque Values

Fastener	Torque Value			Loctite™	Size & Remarks
	ft-lb	in-lb	Nm		
Cylinder head nuts	10.3	123	14		M7 x 1.0
Crankcase bolts	8.8	105	12		M6 x 1.0
Spark plug	(SP)	(SP)	(SP)		M14 x 1.25
Stator bolts	2.1	25	2.8		M5 X 0.8
Stator cover bolts	1.7	20	2.3		M4 X 0.75
Clutch cover bolts	5.8	70	7.9		M6 X 1.0
Clutch nut	40	480	54	263	M10 x 1.25
Clutch bolts	12	144	16	263	M6 x 1.0
Engine mount bolts	22	265	30		M8 X 1.25
Swingarm pivot	21	250	28		M14 X 2.0
Shock bolt	35	420	47	243	M10 x 1.5
Water pump impeller	6	75	8	243	M5 x 0.8
Water pump pulley	10	124	14	243	M6 x 1.0
Intake manifold bolts	4.6	55	6.2		M6 X 1.0
Axle nuts	25	300	34		M12 X 1.25
Rear sprocket bolts	16	195	22	243	7 mm
Rear brake rotor bolts	9	108	12	243	M6 x 1.0
Triple clamp bolts (top)	9	108	12		M6 x 1.0
Triple clamp bolts (bottom)	6	72	8		M6 x 1.0
Ignition rotor nut	30	400	45	243	M10 x 1.25

(SP) To apply the proper torque to the spark plug when inserting, one must first screw the spark plug in until the metal gasket ring causes resistance and then turn another 1/8 to 1/4 turn.

Break-In Procedure

Your Cobra CX50 FWE King is a close-tolerance high performance machine and break-in time is very important for maximum life and performance. The CX50 can be ridden hard after the first ½ hour break-in time.

Cobra recommends *Bel-Ray H1-R* premix oil with high octane pump gas mixed at 40:1 (150 ml oil to 2 gallons of gas). Other brands of oil should be mixed at 32:1 for break-in.



CAUTION:

Failure to use proper fuel, oil, or fuel/oil mixture may result in premature engine wear or damage to the machine.

Adhering to the following break-in schedule will result in long lasting high performance machine.

- Start bike on stand
- First 5 minute period, operate the bike on the stand with a combination of idle and high RPM operation. (avoid prolonged high RPM but spin the rear wheel good at least once or twice per minute)
- Allow bike to cool
- Ride for 15 minutes maximum (avoid prolonged high RPM operation and avoid abusing the clutch with throttle blipping).
- Cool and inspect bike for loose fasteners.
- Next ½ hour of operation, avoid prolonged operation at Wide Open Throttle.
- After 1 hour of operation
 - Check for loose bolts and nuts on the bike and retighten as necessary (proper torque values are listed under Specifications).
 - Clean the carburetor bowl.
 - Change the transmission / clutch lubricant.
- Check CFD torque and adjust as necessary
- After 8 hours of operation
 - Change the fork oil.
 - Have a Certified Cobra Mechanic change the shock oil.
- Your bike is now ready for the highest level of competition!

NOTE:

During break-in the bike will likely lose some engine coolant through the radiator overflow hose. Losing up to 4 oz (120 ml, ½ cup) is normal. Proper coolant level will cover the top of the radiator cores. Removing the radiator cap and looking inside is the only way to check the coolant level.

WARNING

Never open the radiator cap of a machine that has a hot or warm engine or one that has recently been ridden. Burning and scalding could occur.

Starting Procedure

Before starting the machine inspect the following:

- Tire pressure
- Chain tension
- Coolant level
- Proper wear on chain rollers and sliders
- Handlebar tightness
- Throttle assembly movement/cable adjustment
- Air Filter
- Check for loose nuts and bolts
- Turn the fuel on by rotating the fuel petcock knob to the vertically downward position (reserve position is horizontally forward)

NOTE: For best results from your Cobra Motorcycle use only the recommended fuels. Testing has shown that most 'race' fuels actually degrade performance.

WARNING

Always wear a helmet and other protective riding gear.

When your pre-ride inspection is complete the bike may be started. For a cold engine follow this procedure.

1. Place the motorcycle on a stand of sufficient strength that positions the motorcycle in a level upright position with the rear wheel off the ground.
2. Pull up the choke knob and turn it to lock it.
3. Kick start the engine.
4. Rev the engine in short spurts, turning the throttle no more than 1/4 open until the engine will run without the choke.
5. Verify a functional engine shut-off switch by shutting off the engine.
6. Restart the engine and proceed with riding when the engine is sufficiently warm (i.e. the side of the cylinder is warm to touch).

CAUTION:

Never rev an engine full throttle when it's cold or slightly warmed up and, for best clutch performance, warm up the bike before taking off.

WARNING

This is a high performance race motorcycle. Too much application of throttle will likely land your little racer on his or her arse. Fenders can be replaced but bruised egos and other body parts take longer.

CAUTION:

Cobra recommends that you tell your child to take it easy the first couple of minutes in practice until the engine comes up to full operating temperature.

CAUTION:

Make sure your riders' foot is not resting on the foot brake while they are riding.

Maintenance

A properly maintained machine is safer, faster, and more fun to ride. It is important that you adhere to this maintenance schedule so as to promote the longevity of your Cobra Motorcycle.

Tips

1. Recommended lubricants:
 - a. Cobra Clutch Milk is by far the best **auto clutch lubricant**. It is a full synthetic lubricant that has been specifically formulated for Cobra's auto clutch and has;
 - Exceptional film strength over petroleum based oils or synthetic blends.
 - Extreme temperature tolerance.
 - NO frictional modifiers.
 - Dispersant package to keep clutch fibers in suspension so they can be flushed out when the oil is changed.
 - Extremely low viscosity for minimal drag and 'windage'.
 - b. *Bel-Ray H1-R* oil is the recommended **premix oil** because:
 - Its Ester base leaves a film on all parts at all times. No metal to metal startups or corrosion potential.
 - Exception film strength over petroleum based oils or synthetic blends.
 - Easily atomizes and burns completely.
 - Does not fall out of suspension from premix in cold weather.
 - Produces virtually no coking deposits, leaving pistons, rings and heads extremely clean with minimal pipe 'spooge'.
2. Filling your transmission with more than 8.0 oz (235 cc) of lubricant may help to transfer heat from the clutch. Filling with more than 12 oz (350 cc) will degrade performance.
3. The cylinder base gasket has been 'fitted' for your engine. The code number stamped into the engine cases will guide you to what thickness base gasket is required during a common top end service. See the service section of this manual to correspond a code number with a base gasket part number.
4. Evaluate the bikes jetting only after it has been warmed up to race temperatures.
5. New chains will stretch on first use. Never install a new chain prior to a race. Always 'break' them in during practice.
6. Your Cobra Motorcycle has a 10 digit VIN (Vehicle Identification Number). The first two digits indicate the model and the seventh indicates the model year (MY).
 - a. Example, ACxxxx9xxx is a 2009 MY CX50 SR.
7. Because of the amount of heat generated by the clutch and engine during extended periods of riding, it is advisable to remove the ignition cover afterward to allow the ignition to cool off. The heat transfers through the

cases and can damage the stator as it cools off because of lack of airflow around the stator.

8. If you ever need to weld anything on the bike, disconnect the spark plug cap, unplug the ignition, disconnect the kill switch, scrape the paint bare near the area to be welded and put the ground clamp as close to the area to be welded as possible.

WARNING

Be sure the fuel tank and carburetor have been removed and safely located away from the welding process.

9. The frame is 4130 Chrome Moly and it is important to weld it with the proper rod and heat settings set as light as possible. Cobra recommends replacing the frame with a new one if the old one becomes damaged. Use ER70S6 filler if welding on the frame.
10. If your kick-starter lever does not return properly, first try loosening the six kick/clutch cover screws ½ turn. Hold the kick lever ½ way down while retightening the six screws starting for the center and working out
11. Inspect CFD slip torque after the 2nd ride and then again after the 6th ride. After this follow the recommended schedule below.
12. Check proper clutch engagement before and after each ride. If the clutch is engaging properly DO NOT feel the need to take the clutch apart to; measure the spring stack, clean the stack, replace the springs, etc... Cobra has worked very hard to make a clutch that is low maintenance and so only take it apart if it NEEDS to be maintained.

Schedule

- Prior to each ride
 - Check the air filter (clean and re-oil as necessary).
 - Insure the smooth operation of the throttle cable (throttle soundly 'clacks' shut).
 - Check for frayed strands of the throttle cable inside the throttle housing and replace if necessary.
 - Check for adequate tire pressures and adjust if necessary.
 - Check all nuts and bolts for proper torque and re-torque if necessary.
 - Spray all moving parts with WD40 or other light oil.
 - Check drive chain for
 - Proper tension and adjust if necessary.
 - Adequate lubrication and lubricate if necessary.
 - Insure that the ignition stator and rotor are clean and dry.
 - Check the frame for cracks in the metal or cracks in the paint that might indicate that the metal has been stressed beyond it's safe limits. Replace or get properly rewelded as necessary.
 - Check the rims for signs of stress, like cracks around the rim, spokes and hub.
 - Equalize the pressure in the forks with atmosphere.
- Every 2 hours of operation

- Replace the transmission oil.
- Check the CFD torque.
- Every 10 hours of operation
 - Replace the fork oil.
 - Have the shock oil replaced by a Certified Cobra Mechanic.

Replacing Transmission / Clutch Lubricant

Tools needed:

- 5mm allen wrench
- Minimum of 250 ml (8 oz) *Cobra Venom 3 Shoe Clutch Milk* (Part #MCMUGF32).

Procedure:

1. Begin this procedure with a bike that has been ridden more than 5 minutes but less than 10 minutes. It is desired to have the engine warm enough so that the oil is 'runny' but not so hot that there is risk of being burned by the engine or the oil.



Hot oil and hot components on the motorcycle may cause burns.

2. Remove the oil drain plug located on the right side of the engine, on the clutch cover, near the brake lever (figure 1).

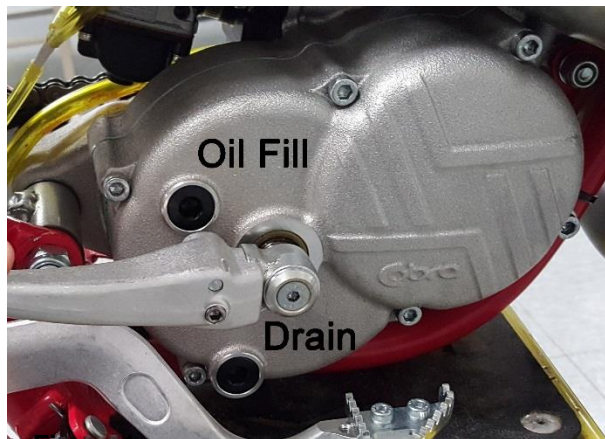

Figure 1

3. After it has drained, reinstall the plug, being sure that the gasket is in place.
4. Reapply oil from oil fill plug 250 cc (8 oz) *Cobra Venom 3 Shoe Clutch Milk* thru the oil fill plug.

NOTE: Putting additional oil, up to 350 ml (12 oz), can help clutch life. More than 350 ml (12 oz) will degrade engine performance.

NOTE: It can be helpful to lean the bike over on its left side to add oil to the bike.

5. Reapply the oil fill plug, hand tight, being sure the gasket is in place.

CAUTION:

Cobra has spent considerable time and money developing the proper lubrication to handle the harsh environment of the automatic clutch and transmission of this motorcycle. Cobra's specially developed *Cobra Venom 3 Shoe Clutch Milk* (Part #MCMUGF32) was formulated to provide superior lubrication and cooling capability over extended periods of time and is the recommended lubricant for your Cobra motorcycle.

Proper Chain adjustment

Tools required for chain adjustment

- 19 mm wrench or socket
- 13 mm wrench or socket

1. Make sure that the rear wheel is aligned properly.
2. For proper adjustment, the chain should have 35 mm (1 3/8") free movement just behind the chain block with no load on the bike (figure 2)

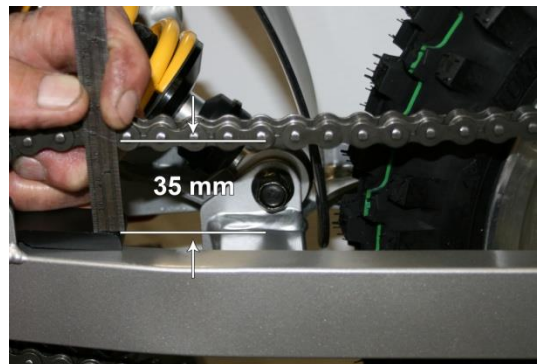
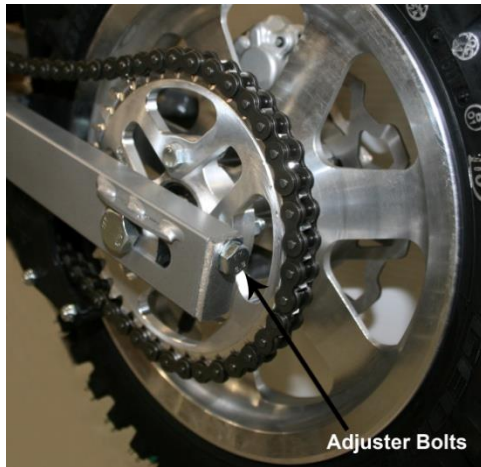

Figure 2

CAUTION:

Sit on the bike and verify that the chain has a minimum of 12mm (1/2") free movement when the chain is at it's tightest point.



3. If the chain requires adjusting, loosen the axle with a 19 mm wrench and tighten the chain by rotating the adjuster bolts clockwise (CW) or loosen the chain by rotating the adjuster bolts (CCW).
4. Retighten the axel bolt to 25 ft-lb (34 Nm).
5. Retighten the adjuster bolt

Rear Brake Maintenance

CAUTION:

Too little brake pedal free-play will allow the brake pads to drag causing the pads to wear prematurely and possible engine component failures. Too much free-play will not allow the rider to apply the brakes quickly.

1. Set pedal height/position first, then
2. Set pedal free play.

Brake pedal height can be adjusted with the bolt and nut located under the rear of the brake pedal. The free-play is adjusted with the adjustable plunger on the end of the brake pedal.

CAUTION:

Use only DOT 4 brake fluid

Setting rear brake pedal position (see figure 2b):

1. Loosen the lock nut (10mm wrench).
2. Adjust the brake lever stop (10mm wrench) so that the lever is comfortably reachable in both:
 - a. Standing riding position, and
 - b. Sitting riding position.
3. Tighten the lock nut (10 mm wrench).

CAUTION:

Adequate pedal free play is required so that the brake pads do not drag on the rotor. 1" MINIMUM.

⚠ WARNING

Make sure that the free play locking clip is installed such that one must push forward, toward the front of the bike, to remove. Otherwise the clip is apt to come undone while riding.

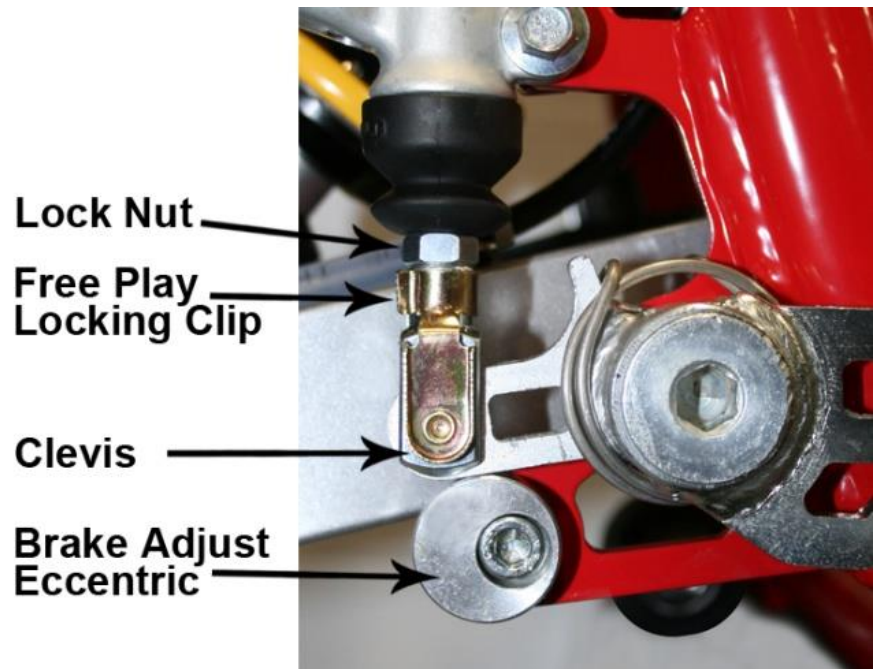

Figure 2b

To adjust (see figure 2b):

1. Loosen the lock nut (10mm).
2. Undo the free play locking clip from around the brake adjustor (plunger), with your hand by pushing it forward.
3. Slide the pin of the locking free play locking clip from the brake lever

4. Adjust as needed by rotating the clevis on the end of the adjustor (plunger).

NOTE: Turning the clevis Clockwise will lengthen the adjustor (plunger), removing free play from the system, and turning the clevis Counter-Clockwise will shorten the adjustor (plunger) adding free play to the system.

Brake Bleeding Procedure

Tools Required:

- Front: T10 Torx bit/driver, Cobra bleed kit (BCKG0031)
- Rear: 3mm hex key (Allen wrench, T10 Torx bit/driver, Cobra bleed kit(BCKG0031)

Procedure:

- Remove the brake fluid reservoir cover.
- Fill the syringe half full with brake fluid.
- Remove the brake caliper bleed screw.
- Attach the syringe to the brake caliper bleed access. Keep the syringe oriented as not to allow air from the syringe into the system.
- Using the syringe pull fluid through the system. Use caution not to let the fluid in the reservoir to become low and introduce air into the system.
- Using the syringe push fluid back into the system until the reservoir is full.
- Repeat these actions of pulling and pushing fluid through the system a few times.
- With the reservoir full, engage the brake lever/pedal and hold it there as if engaging the brakes.
- While doing this pull on the plunger of the syringe. Doing this will cause a vacuum in the system. The vacuum will swell the air bubbles which assist in them moving throughout the system.
- Continue pulling a vacuum and release the brake lever/pedal (careful not to allow the reservoir to become empty).
- Once again engage the brakes while continuing to pull a vacuum.
- When the reservoir is almost empty stop and push fluid back into the system.
- Repeat these steps with the vacuum until no more air bubbles can be removed from the system.

- Remove the syringe. Be sure to keep the caliper below the level of the reservoir to allow the fluid to run out of the caliper and not allowing air into the system.
- Reinstall the bleed screw, being sure that the ring is in place.
- Fill the reservoir with fluid (the fluid should be full enough that the fluid spills out when placing the lid on) and replace the cover.

Air Filter Cleaning

- Remove the seat
- Squeeze the two tabs together as shown in figure A1 and pull the wire retainer up and out of the air box
- The filter may now be pulled from the airbox
- Clean the airbox of dirt and clean the filter sealing surface of the old sealing grease.

CAUTION:

Pay particular attention to clean any particles from the airbox between the filter location and the carburetor.

NOTE: Cobra has available a carburetor cover that allows easy cleaning of the airbox.

1. Remove the air boot
2. Install the cover (RCMU0109) over the carburetor inlet
3. Spray out the airbox.



Figure A1

⚠ WARNING

Do not clean the air filter with gasoline or other highly volatile petroleum product. Diesel fuel or kerosene would be preferred but caution should still be taken. Hot soapy water works well.

1. Clean the filter in hot soapy water to remove all dirt particles.
2. Allow it to dry thoroughly.
3. Saturate with filter oil and remove excess.

NOTE: It's very important to oil your filter consistently each time because varied amounts of oil will change your carburetor jetting.

4. Apply grease to the black sealing surface of the filter and reinstall.
5. Squeeze the two finger tabs together on the wire retainer and install into the airbox as in figure A2



Figure A2

6. Push the wire retainer down until it bottoms, making sure the two bottom tabs on the retainer go through the two associated holes in the bottom of the airbox.
7. Push the two top retainer arms out so that they properly insert into each side hole.

CAUTION:

If the side arms do not align with the associated holes it is quite likely that the legs did not make it into the holes. Realign and try again.

8. When properly installed, the filter and retainer should look like figure A4.



Figure A4



NOTE: Make sure you change or clean your filter after each moto. We recommend carrying multiple filters in your toolbox, one for each practice session and moto.

Fork Maintenance

Cobra strongly recommends that a professional service technician conduct all internal maintenance other than changing springs and oil. This will help to ensure safe and consistent operation.

For routine maintenance, the chart below provides suggested service intervals for common procedures:

	<u>Each Ride</u>	<u>10 hours</u>	<u>20 hours</u>	<u>As Needed</u>
<u>Bleed excess air</u>	<u>X</u>			
<u>Change Oil</u>		<u>X</u>		
<u>Change Seal/Striper</u>			<u>X</u>	
<u>Change Bushings</u>				<u>X</u>

Fork Air Bleeding

Tools required

- 3mm hex key (Allen wrench)

During normal operation, both fork legs will build up air pressure. This pressure acts as an additional spring so it must be bled on a regular basis to maintain consistent suspension operation. Before each ride, loosen the socket head cap screw located at the front of each fork cap far enough so that any excess pressure in the leg is relieved. After excess air is bled off, retighten the screw to 5 in-lb. Be careful not to lose or damage the sealing ring that is located under the head of each bleed screw.

Fork Oil Replacement

Tools required

- 32mm Fork Cap Tool (MCMUTL32)
- 19mm wrench or socket
- 4 & 5 mm hex key (Allen wrench)
- 9/16 wrench
- Mallet
- 2.5 wt. Bel-Ray fork oil



Disassembly procedure

1. Remove the front wheel (19 mm wrench).
2. Remove the brake caliper from the fork leg (4 mm hex key).
3. Loosen the fork caps (32mm fork cap tool).
4. Remove the fork legs from the triple clamps (5 mm hex key).
5. One leg at a time
 - a. Remove the fork cap from the fork tube.
 - b. Pull the fork spring down to gain access to the fork cap jam nut and secure it with a 9/16 wrench.
 - c. Holding in one hand the 9/16 wrench use the fork cap wrench to unscrew the fork cap from the damper rod.
 - d. Remove the fork spring pad, and fork spring.
 - e. Inside the damper rod, the rebound adjustment screw pin is resting and will fall out of the damper rod when the fork is inverted. Try to catch it before it falls into your oil bucket.
 - f. Invert the fork and allow the oil to drain completely. Working the damper rod up and down will speed up the draining process.

Assembly procedure

1. Fill the fork with 155ml of fork oil.
2. Work the damper rod up and down to allow the fork cartridge to fill with oil.
3. Install the rebound adjustment screw pin into the damper rod.

4. Install the fork spring and spring pad.
5. Extend the damper rod completely and Compress the fork spring enough to begin threading the fork cap back onto the damper rod.
6. Make sure that the fork cap threads onto the damper rod completely before it makes contact with the jamnut.
7. Tighten the jamnut.
8. Tighten the fork cap to the fork leg outer
9. Pump the fork leg several times to verify that it operates smoothly.
10. Install each leg back into the triple clamp. Torque each pinch bolt to 8N-m (6 ft-lb) making sure both legs are set to the same height in the clamps.
11. Reinstall the brake caliper.
12. Reinstall the front wheel (25 ft-lb, 34 Nm).

Frictional Drive (V3 CFD)

The Cobra Frictional Drive (CFD) is essentially an adjustable slip clutch that dissipates torque spikes transmitted from the rear wheel to the rest of the drive line and engine. Instead of these torque spikes potentially damaging internal components, the CFD allows the transmission to slip with respect to the engine. For this to occur, the CFD must function properly by 'slipping' above a minimum torque value.

The safe minimum slip torque of the CFD should be checked every 2 hours of operation, after break-in.

The slip torque value should be above 80 ft-lb (108 Nm) measured at the sprocket with the following process.

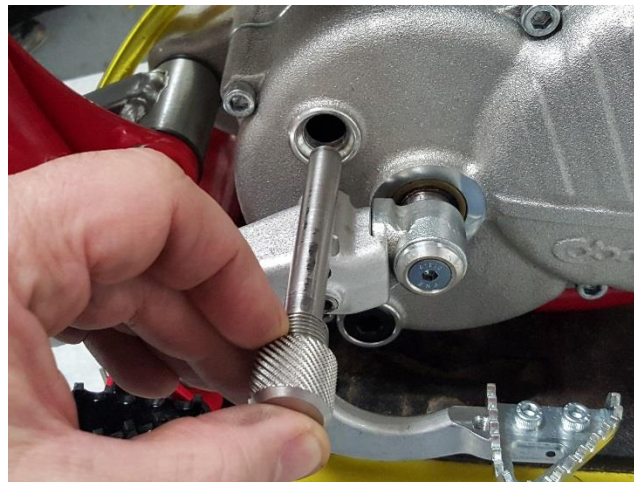

To properly measure the minimum torque at which the CFD (Cobra Frictional Drive) slips

1. Remove the oil fill plug and install the check tool/pin MCMUTL40.
2. Make sure that it is threaded in completely until it bottoms out.
3. Install the Sprocket Socket CFD torque checking tool (MCMUTL15) on the output shaft protruding through the sprocket.

CAUTION

It may be necessary to remove the ECKGSR03 sprocket clip, or the sprocket entirely, to ensure good engagement between the tool and the shaft

4. Verify with a torque wrench applied to the Sprocket Socket that the V3 CFD does not slip below 108 Nm (80 ft-lb) in either direction.
5. If there is slippage below 108 Nm (80 ft-lb) remove the cotter pin and tighten the castle nut on the CFD one more position (it is a left hand thread nut so you must turn it counter clockwise)

NOTE: This V3 CFD torque checking method is possible to do with the chain on. Just put the bike on a stand so that the rear wheel can turn freely.

NOTE: The CFD hubs can be removed with the universal puller (MCMUTL70).

If it slips below the value, the CFD must be readjusted as per described in the service section of this manual.

NOTE:

If the bike makes a whir, whir, whir, sound coming from the clutch side engine cover it is very probable that the CFD has slipped enough that the brass bushing has worn sufficiently to let the gear operate off center. Time to install a CFD refresh kit.EKMU



Parts – Airbox & Inlet System

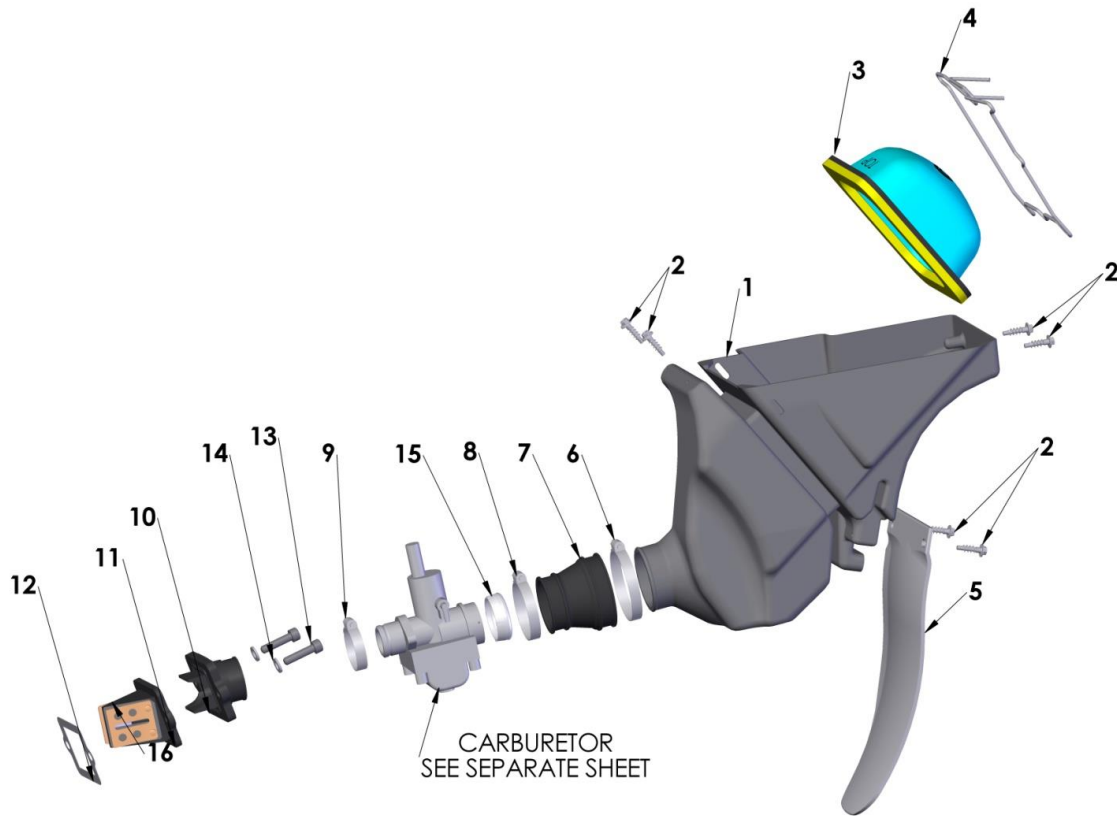

Air Box		
REF #	PART #	DESCRIPTION
	RCMU0018	CARBURETOR
1	TCCS0002	AIRBOX
2	HCSP0004	SCREW – PLASCREW - ALUMINUM
3	RCCS0016	AIR FILTER
4	RCKG0503	RETAINER – AIR FILTER
5	TCC60008	MUDFLAP
6	MCKGHO03	HOSE CLAMP – AIRBOX TO BOOT
7	RCKG0505	AIR BOOT
8	MCKGHO01	HOSE CLAMP – BOOT TO CARB
9	MCKGHO04	HOSE CLAMP – CARB TO MANIFOLD
10	RCMU0036	INLET MANIFOLD – 2016.5
11	ECMU0246	REED CAGE ASSEMBLY WITH REEDS VFORCE
12	ZCCS0001	GASKET – REEDS TO ENGINE
13	HCBC0603	M6X30mm SOCKET HEAD CAP SCREW
14	HCWF0601	6mm FLAT WASHER
15	RCCM1301	VELOCITY STACK (SCREWS ONTO CARB)
16	ECCS0030	REED REPLACEMENT KIT

Parts – Bars and Controls

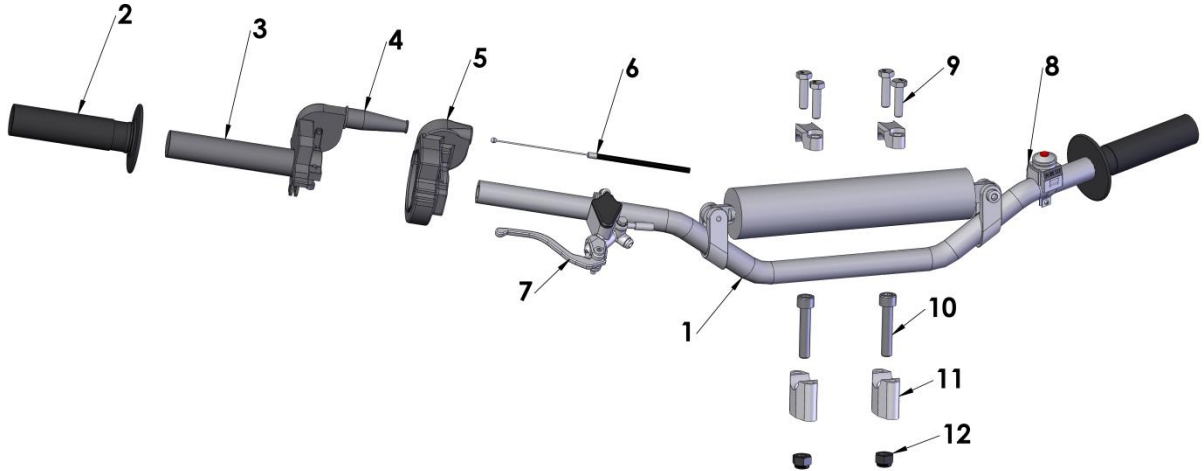

Bars and Controls		
REF #	PART #	DESCRIPTION
1	FAMU0014	HANDLEBAS – PRO TAPER MICROBARS – COBRA BEND
2	TCMU0021	GRIPS (SET OF TWO) – MICROGRIPS – RED / GRAY FEW
3	FAMU0016	THROTTLE ASSEMBLY – PRO TAPER COBRA
3A	FAMU0015	TUBE ASSEMBLY – THROTTLE – 2 PIECE PRO TAPER MICRO
3B	HCBC0525	M5 X 25 SHCS – THROTTLE ASSEMBLY
3C	FCMU0041	STOP RING – MICRO BAR THROTTLE
4	FCPW0004	CABLE COVER
5	FCMU0021	THROTTLE COVER
6	FCMU0019	THROTTLE CABLE
6A	HCNJ0801	NUT – 8MM JAM
7	BAKG0003	BRAKE ASSEMBLY FRONT
8	FCMU0033	KILL SWITCH ASSEMBLY
9	HCBC0806	M8X30mm SOCKET HEAD CAP SCREW (4 REQ'D)
10	HCBC1001	M10X45mm SOCKET HEAD CAP SCREW (2 REQ'D)
11	TKMU0404BLK	BAR MOUNT KIT, SHORT (1 REQ'D) STANDARD
11A	TKMU0403	BAR MOUNT KIT, TALL (1 REQ'D)
12	HCNL1001	M10 LOCK NUT
ACCESSORY	BCKG0023	ALLOY BRAKE LEVER W/BALL
ACCESSORY	BCKG0024	BRAKE PERCH ASSY W/LEVER & BALL

Parts – Carburetor

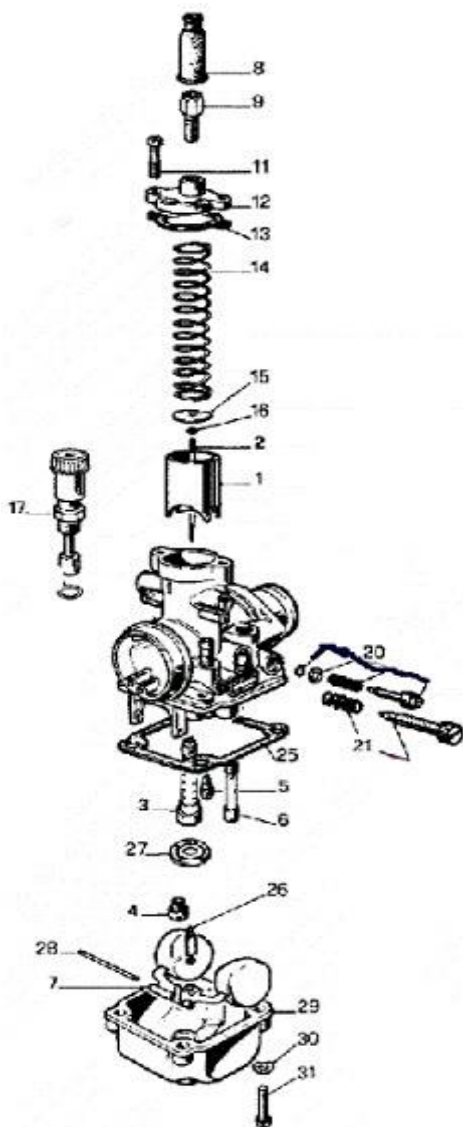

Carburetor		
REF. #	PART #	DESCRIPTION
	RCMU0018	CARBURETOR
1	RCMU0305	SLIDE - #40
2	RCMU0601	NEEDLE - W7
3	RCMU0023	ATOMIZER 2.62 AU
4	RCMU00xx	MAIN JET, xx denotes size
5	RCMU00xx	PILOT JET, xx denotes size
7	RCMU0301	FLOAT
8	RCMU0102	RUBBER CABLE CAP SEAL
9	RCMU0003	CABLE ADJUSTOR
11	RCMU0006	TOP CARB SCREW
12	RCMU0106	CARB TOP
13	ZCMU0007	TOP CARB GASKET
14	RCMU0004L	SLIDE SPRING - LIGHT
15	RCMU0028	NEEDLE RETAINER PLATE
16	RCMU0007	NEEDLE CLIP
17	RCMU0204	CHOKE ASSEMBLY
NOT SHOWN	RCMU0209	O-RING CHOKE ASSEMBLY
20	RCMU0009	FUEL MIXTURE SCREW
21	RCMU0011	IDLE ADJUSTMENT SCREW
25	RCMU0103	FLOAT BOWL GASKET
26	RCMU0107	FLOAT NEEDLE
27	RCMU0012	DIFFUSER
28	RCMU0016	FLOAT RETAINER PIN
29	RCMU0108	FLOAT BOWL
30	HCWF0401	WASHER 4MM FLAT
31	RCMU0201	SCREW – FLOAT BOWL
NOT SHOWN	RCCM1301	VELOCITY STACK
NOT SHOWN	MCKGHO01	CLAMP – CARBURETOR TO FILTER
NOT SHOWN	RCCS0006	FUEL LINE, 5"
NOT SHOWN	MCMUCL04	HOSE CLAMPS – FUEL LINE
NOT SHOWN	RCMU0018	CARBURETOR COMPLETE 19 mm
NOT SHOWN	RCMU0020	ELBOW - CARB VENT
NOT SHOWN	RAMU0001	CANNULUS - Y STYLE CARB VENTS
NOT SHOWN	RCMU0031	SLIDE - #30
NOT SHOWN	RCMU0250	SLIDE - #50
NOT SHOWN	ECKG0160	SLIDE - #60
NOT SHOWN	RCMU0026	NEEDLE - W4
NOT SHOWN	RCMU0602	NEEDLE - W16

PILOT JET		MAIN JET					
48	RCMU0048	85	RCMU0085	92	RCMU0092	99	RCMU0099
50	RCMU0050	86	RCMU0086	93	RCMU0093	100	RCMU1100
52	RCMU0052	87	RCMU0087	94	RCMU0094	101	RCMU1101
55	RCMU0055	88	RCMU0088	95	RCMU0095	102	RCMU1102
60	RCMU0060	89	RCMU0089	96	RCMU0096		
65	RCMU0065	90	RCMU0090	97	RCMU0097		
		91	RCMU0091	98	RCMU0098		

Parts – Coolant System

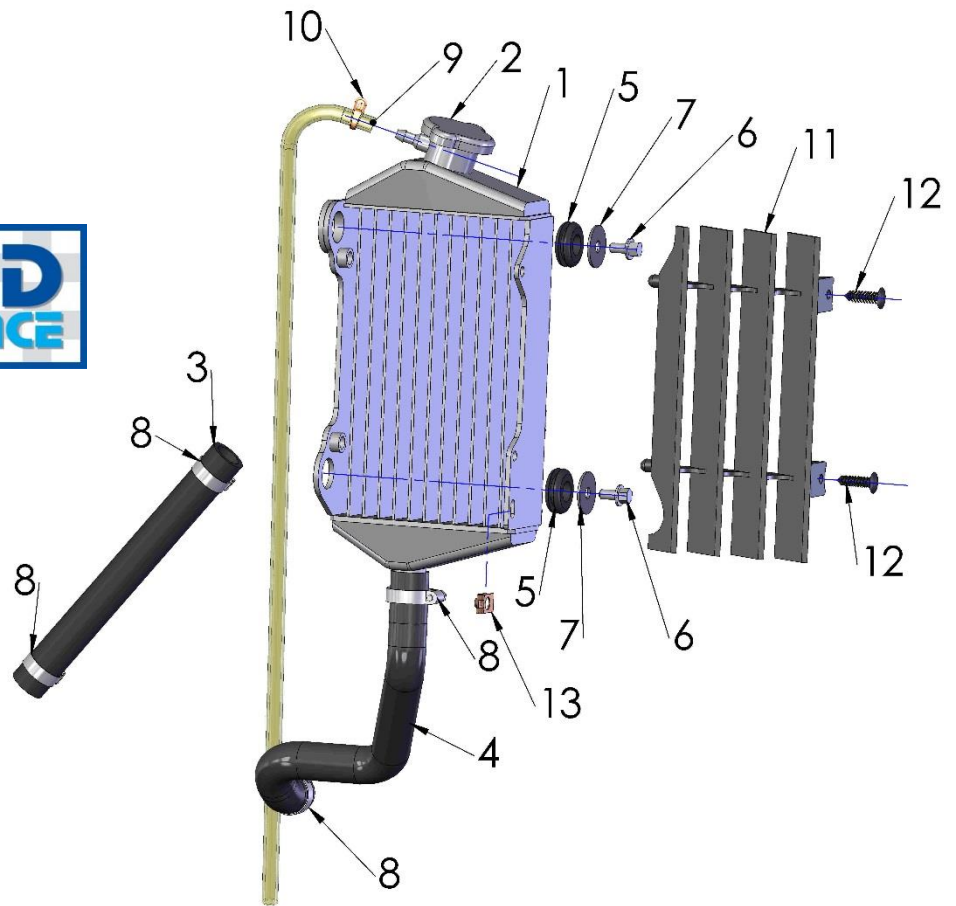

Coolant System		
REF #	PART #	DESCRIPTION
1	FCCS0058	RADIATOR WITH CAP - 2016
2	FCMU0052	CAP, 1.3 BAR, WITH RIBS
3	ECCS0014	RADIATOR HOSE, TOP, LEFT
4	ECMU0275	RADIATOR HOSE, BOTTOM
5A	MCMUGR03	GROMMET, RADIATOR MOUNTING (TOP) THICK ONE
5B	MCC6GR01	GROMMET, RADIATOR MOUNTING (BOTTOM) ONE
6	HCBF0616	M6X16mm FLANGE HEAD BOLT (2 REQ'D)
7	HCWF1478	FLAT WASHER (2 REQ'D)
8	MCMUCL07	HOSE CLAMP (4 REQ'D)
9	FCKG0214	RADIATOR OVERFLOW HOSE, 22"
10	MCMUCL05	HOSE CLAMP FOR OVERFLOW HOSE
11	FCCS0043	LOUVER
12	HCSP0002	PUSH PIN (2 REQ'D)
	HCPP0001	PUSH PIN - REMOVABLE
13	HCCN0000	5mm CLIP NUT

Parts – Electrical System

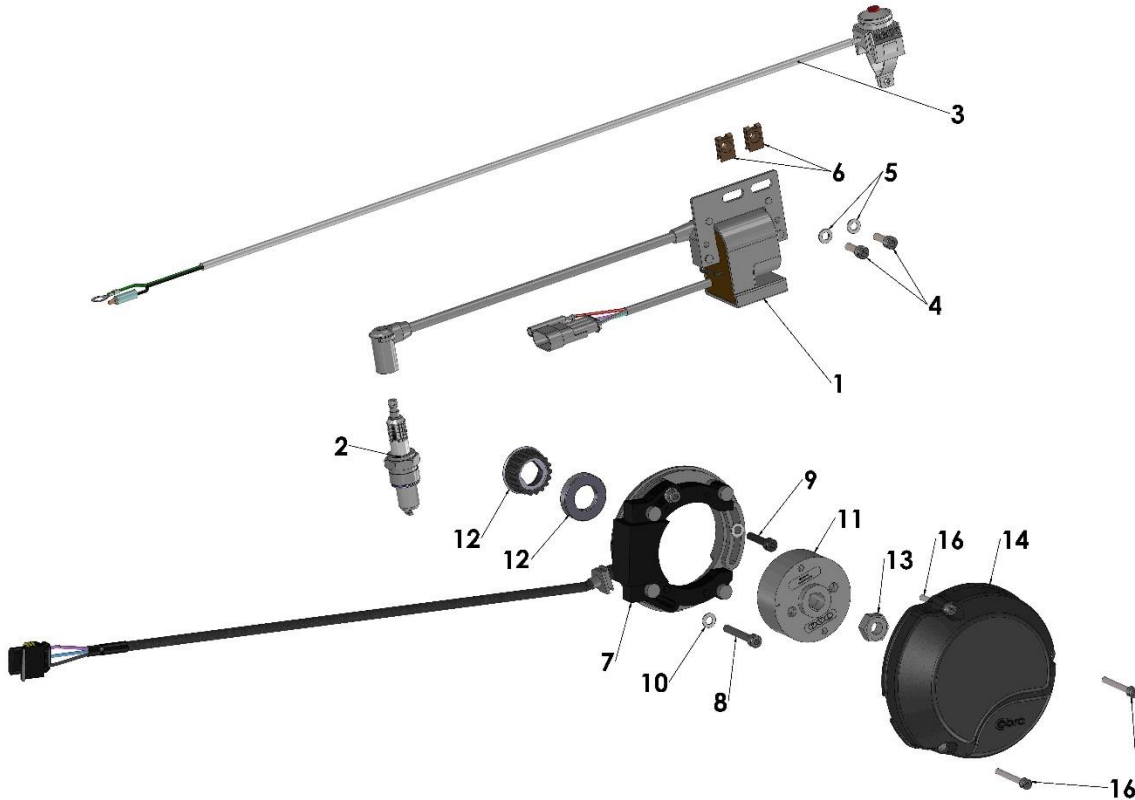

Electrical System		
REF #	PART #	DESCRIPTION
1	IAMU0005	COIL/CDI W/SPARK PLUG CAP
2	ECMU0010C	SPARK PLUG, AUTOLITE COPPER
2A	ECMU0010I	SPARK PLUG, AUTOLITE IRIIDIUM
3	FCMU0033	KILL SWITCH ASSEMBLY
4	HCBC0516	M5X16mm SOCKET HEAD CAP SCREW (2 REQ'D)
5	HCWF0501	5mm FLAT WASHER (2 REQ'D)
6	HCCN0000	5mm CLIP NUT (2 REQ'D)
7	ICMU0023	STATOR WITH GROMMET
8	HCBC0535	M5X35mm SOCKET HEAD CAP SCREW (2 REQ'D)
9	HCBC0525	M5X25mm SOCKET HEAD CAP SCREW
10	HCWF0601	6MM FLAT WASHER FOR STATOR (3 REQ'D)
11	ICMU0042	ROTOR – FEW 2016.5
12	EKMU0035	KIT – PULLEYS, SPACER & BELT RETAINER, FWE 2016.5
13	HCNS1001	NUT M10
14	ECFW0001	IGNITION COVER
15		
16	HCBC0401	M4X25mm SOCKET HEAD CAP SCREW (3 REQ'D)
	ICMU0012	WOODRUFF KEY (NOT SHOWN)
NOT SHOWN	FCMU0030	COVER – KILL SWITCH SCREW
ACCESSORY	ICMU0017	SPARK PLUG CAP – 0 Ω



Parts – Engine – Bottom End and Transmission

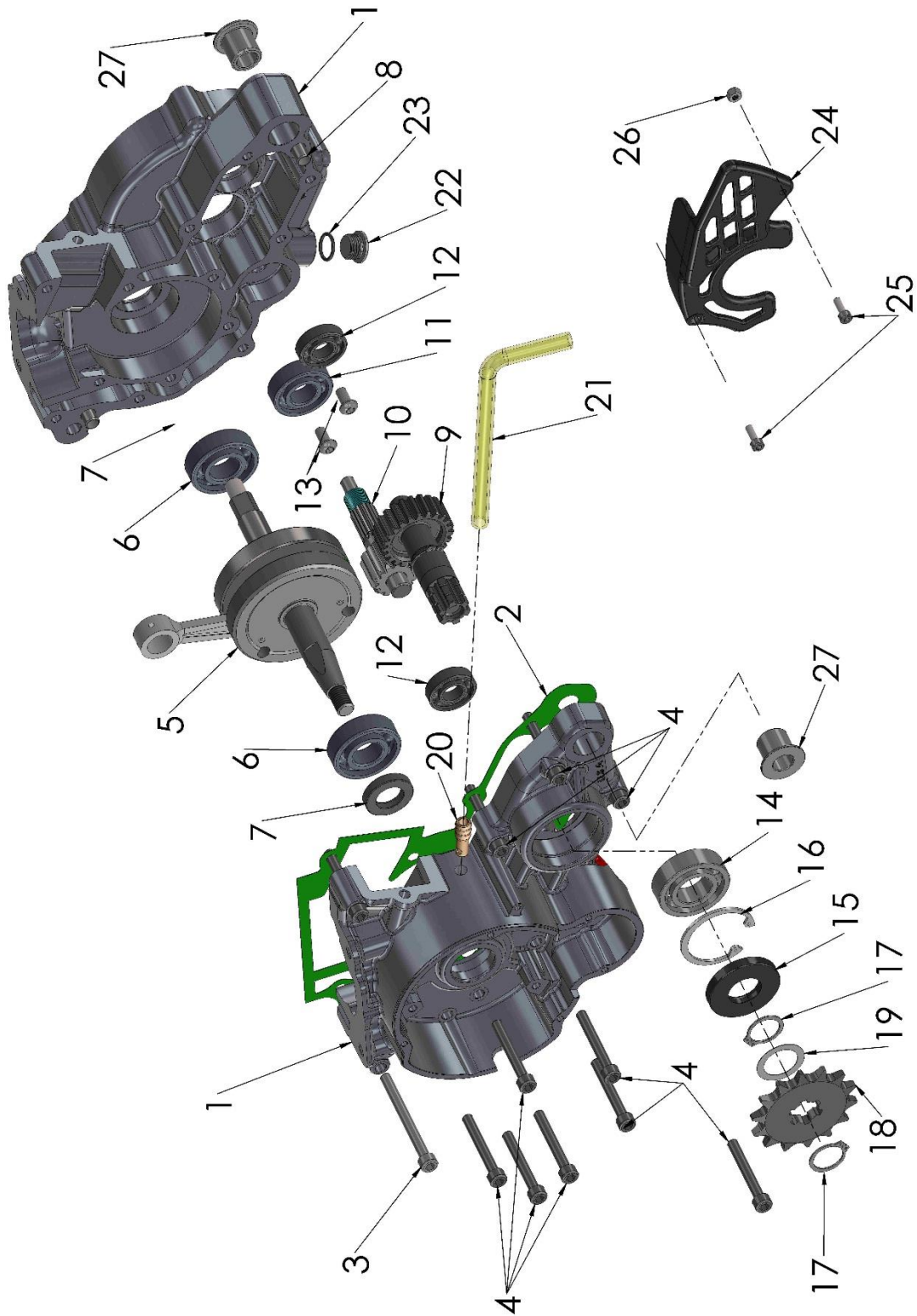

Engine Bottom End and Transmission		
REF #	PART #	DESCRIPTION
1	EKMU0016	CRANKCASE SET WITH BEARINGS, SEALS & GASKET
2	ZCMU0015	GASKET, CRANKCASE CENTER
3	HCBC0665	M6X65mm SOCKET HEAD CAP SCREW (1 REQ'D)
4	HCBC0604	M6X35mm SOCKET HEAD CAP SCREW (12 REQ'D)
5	ECMU0258	CRANKSHAFT - 3 SIDE SPLINE & INTERNAL W/P
6	ECMU0016	BEARING, CRANKSHAFT
7	ECMU0118	SEAL, CRANKSHAFT
8	HCWX0025	DOWEL (HOLLOW), ENGINE CASE ALIGNEMENT (2 REQ'D)
9	ECMU0999	OUTPUT SHAFT, TRANSMISSION WITH GEAR SUPR WIDE
10	ECMU0268	SECONDARY SHAFT, TRANSMISSION WITH GEAR
11	ECMU0001	BEARING, TRANSMISSION SECONDARY SHAFT
12	ECKG0031	BEARING TRANSMISSION SHAFT, (1 EACH CASE HALF)
13	HCBB0612	M6X12mm BUTTON HEAD SCREW BEARING RETAINER (2 REQ'D)
14	ECKGBR01	BEARING, TRANSMISSION OUTPUT SHAFT
15	ECMU0236	SEAL, OUTPUT SHAFT – 2016.5
16	ECMU0237	SNAP RING – OUTPUT BEARING
17	ECKGSR03	SNAP RING, SPROCKET (2 REQ'D)
18	PCKG0015	SPROCKET, 15 T (STANDARD, 13, 14 & 16 available)
19A	ECMU0176	SHIM – SPROCKET .2MM THICK
19B	ECMU0177	SHIM – SPROCKET .3MM THICK
19C	ECMU0178	SHIM – SPROCKET .5MM THICK
20	ECMU0233	FITTING, CRANKCASE VENT – LARGE
21	ECMU0557	VENT HOSE, CRANKCASE
22	ECMU0272BLK	OIL FILL PLUG, 1026.5 BLK
23	ZCMUB014	O'RING – OIL FILL PLUG
24	ECMU0280	COVER – CHAIN AND SPROCKET
25	HCBC0412	M4 X 12MM SOCKET HEAD CAP SCREW (2 REQ'D)
26	HCNL0401	M4 LOCKNUT
27	ECC60028	BUSHING – ENGINE PIVOT – (1 IN EACH SIDE CASE)
	ZKMU2016	COMPLETE GASKET KIT

Parts – Engine Clutch and Kick Lever

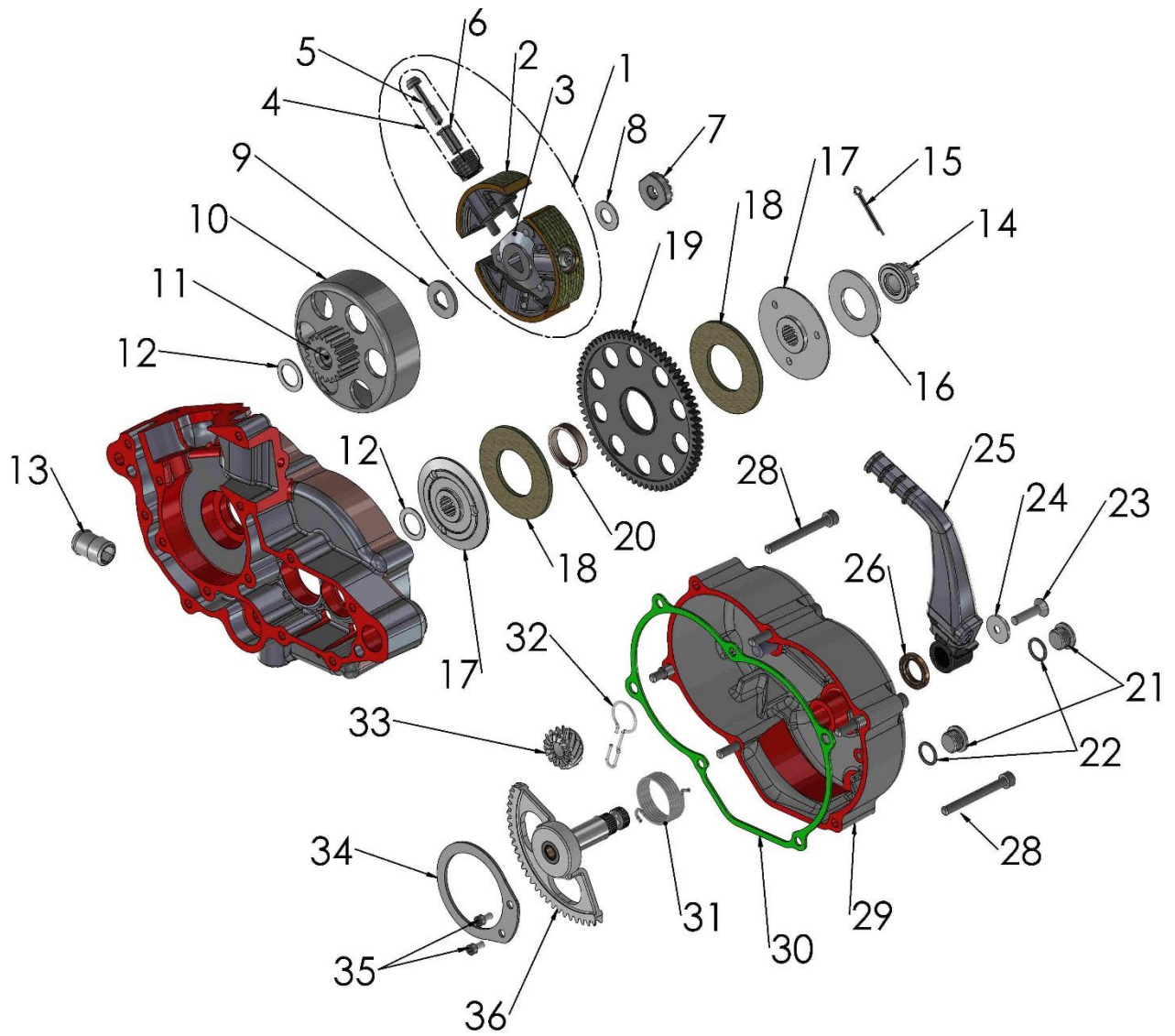

Engine – Clutch and Kick Starter		
REF #	PART #	DESCRIPTION
1	CAMU0002	CLUTCH COMPLETE ASSY - 5GX
2	CAMU0009	3 SHOES & WASHER STACKS W BOLTS - 5GX
3	CCMU0005	CLUTCH ARBOR – 3 SIDED SPLINE
4	CAMU0014	WASHER STACKS - SET OF 3 - CLUTCH - 5GX
5	HCBT0001	BOLT - TORX - 5GX CLUTCH - M6 X 29
6	CCMU0008	SLEEVE - CLUTCH STACK 5GX
7	ECMU0018	CLUTCH NUT, SPECIAL
8	ECDC0030	BELLEVILLE LOCK WASHER
9	CCMU0007	CLUTCH BACKING SPACER
10	ECMU0120	CLUTCH BASKET WITH NEEDLE BEARING
11	ECMU0119	CLUTCH BEARING
12	ECMU0040	CLUTCH TO HUB SPACER(S) (0.030", 0.76mm)
13	ECMU0132	FITTING - COOLANT
14	ECMU0307	NUT V3 CFD
15	HCCP0002	COTTER PIN 3/32 X 1 ½"
16	ECMU0308	BELLEVILLE SPRING V3 CFD
17	ECMU0306	SLIP HUB V3 CFD (2) REQ'D
18	ECMU0249	FRICTION MATERIAL V3 CFDTTHICK (2 REQ'D)
19	ECMU0301	GEAR V3 CFD
20	ECMU0305	BUSHING V3 CFD 7mm
21	ECMU0272BLK	OIL FILL PLUG, 1026.5 BLK
22	ZCMUB014	O'RING – OIL FILL PLUG
23	HCFH0616	M6X16mm FLANGE HEAD BOLT
24	ECMU0250	WASHER – KICK LEVER MOUNTING
25	EAMU0011	KICK LEVER
26	ECDC0078	SEAL - KICKSHAFT
28	HCBC0608	M6X55mm SHCS (2 REQ'D)
29	EAMU0018	CLUTCH COVER ASSEMBLY WITH SEAL AND PIN -2016
30	ZCMU0017	GASKET - CLUTCH COVER
31	ECMU0273	SPRING, KICKSTART
32	ECMUSP01	KICK START DOG SPRING (PAPER CLIP / 'J' SPRING)
33	ECMU0207	KICKSTART GEAR SMALL
34	ECMU0278	BRACKET – KICK SHAFT RETAINING
35	HCBC0508	M5 X 8mm SHCS (2 REQ'D)
36	ECMU0269	KICKSTART GEAR & SHAFT
KIT	HKCP0001	10 PACK OF COTTER PINS (HCCP0002)
KIT	EKMU0002	KICKSTART PIVOT KIT SPRING-BALL-SCREW
KIT	HKAM0022	CLUTCH SHIM HARDEWARE KIT
KIT	EKMU0033	CFD RFRESH KIT W' FRICTIONS, SPRING, BUSHING AND COTTER PINS

Parts – Engine – Water Pump

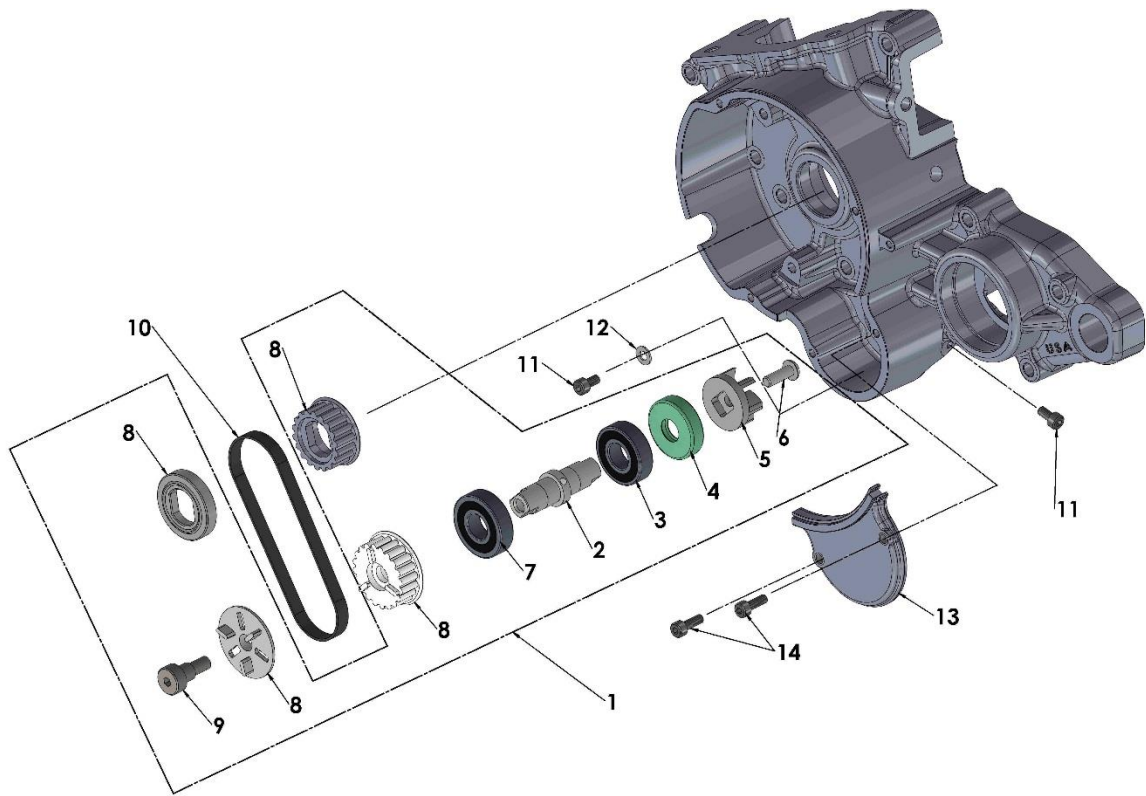

Engine – Ignition and Water Pump		
REF #	PART #	DESCRIPTION
1	EKMU0021	WATER PUMP KIT
2	ECMU0265	SHAFT, WATER PUMP
3	ECKG0072	BEARING, WATER PUMP
4	ECKG0074	SEAL, WATER PUMP SHAFT
5	ECKG0073	IMPELLER, WATER PUMP (ALUMINUM)
6	HCBB0512	M5X12mm BUTTON HEAD
7	ECMU0167	BEARING – WATER PUMP BIG
8	EKMU0035	KIT – PULLEYS, SPACER & BELT RETAINER, FWE 2016.5
9	HCBS0009	SHOULDER BOLT
10	ECKG0170	WATER PUMP BELT
11	HCBC0408	M4X8mm SOCKET HEAD CAP SCREW (2 PLACES)
12	HCWF0401	4MM FLAT WASHER
13	ECMU0274	COVER – WATER PUMP
14	HCBC0412	M4 X 12 SHCS (2 REQ'D)

Parts – Engine – Top End

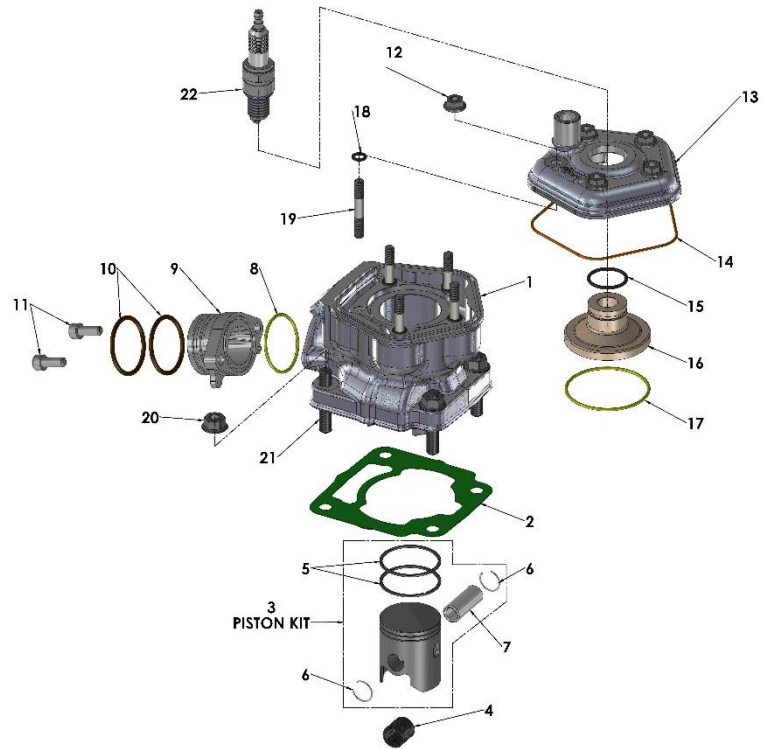

Engine – Top End		
REF #	PART #	DESCRIPTION
1	EKMU0015	CYLINDER KIT (INCLUDES STUDS, PISTON, RINGS, PIN & CLIPS)
2	ZCMU0102	BASE GASKET (0.20mm) THICK
2	ZCMU0103	BASE GASKET (0.30mm) THICK
2	ZCMU0104	BASE GASKET (0.40mm) THICK
2	ZCMU0105	BASE GASKET (0.50mm) THICK
2	ZCMU0106	BASE GASKET (0.60mm) THICK
2	ZCMU0107	BASE GASKET (0.70mm) THICK
2	ZCMU0108	BASE GASKET (0.80mm) THICK
3	ECMU0060A	PISTON KIT – 'A' SIZE (B, C, and D sizes available)
4	ECMU0077	BEARING, WRIST PIN
5	ECMU0155	PISTON RINGS (2 PER SET)
6	ECMUSR00	SNAP RING FOR PISTON (2 REQ'D)
7	ECKG0012	WRIST PIN
8	ZCMUOR07	O-RING, EXHAUST FLANGE
9	ECMU0262	EXHAUST FLANGE
10	ZCMOTE11	O-RINGS – PIPE TO FLANGE (2 REQ'D)
11	HCBC0612	M6X12, EXHAUST FLANGE SCREW (2 REQ'D)
12	HCFN0601	6MM FLANGE NUT (5 REQ'D)
13	ECC60149	CYLINDER HEAD OUTER
14	ZCC60009	O-RING, CYLINDER HEAD LARGE
15	ZCMUOR23	O-RING CYLINDER HEAD SMALL
16	ECMU0264	CYLINDER HEAD, INSERT, 2016.5
17	ZCMUOR05	O-RING CYLINDER HEAD MEDIUM - YELLOW
18	ZCMUOR03	O-RING CYLINDER STUD (5 REQ'D)
19	ECC60107	6MM STUD (5 REQ'D)
20	ECC60109	STUD, CYLINDER 8mm (4 REQ'D)
21	HCFN0801	8MM FLANGE NUT (4 REQ'D)
22	ECMU0010I	SPARK PLUG, IRIIDIUM AUTOLITE, XS61
ACCESSORY	ZKMUOR13	TOP END O-RING KIT

Parts – Exhaust System

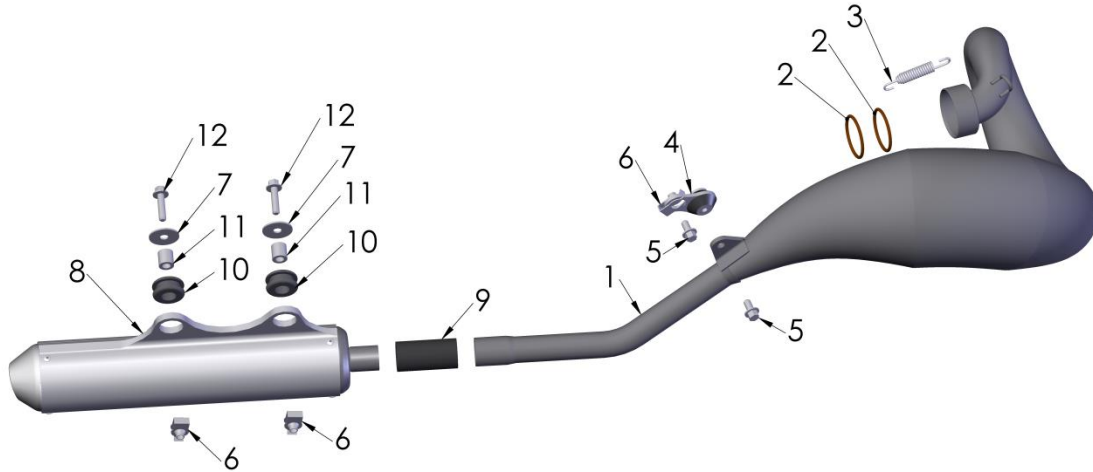

Exhaust System		
REF #	PART #	DESCRIPTION
1	XACS2016FWE	EXHAUST PIPE – FACTORY WORKS
2	ZCMOTE11	HEADER PIPE O-RINGS (2 REQ'D)
3	XCMU0005	SPRING – EXHAUST (2 REQ'D)
4	XCMU0033	ISOLATION MOUNT
5	HCBF0616	M6X16mm FLANGE HEAD BOLT (2 REQ'D)
6	HCHA0003	6mm CLIP NUT – FOR FRONT PIPE MOUNT
7	HCWF1478	PIPE GROMMET WASHER (2 REQ'D)
8	XCMU0032	SILENCER
9	XCC60017	PIPE / SILENCER SEAL
10	MCMUGR03	MOUNTING GROMMET (2 REQ'D)
11	TCKG0001	SPACER (2 REQ'D)
12	HCBF0630	M6X30mm FLANGE HEAD BOLT (2 REQ'D)
ACCESSORY	XCMU0026	SILENCER PACKING KIT

This Page Intentionally Left Blank

Parts – Forks & Triple Clamps

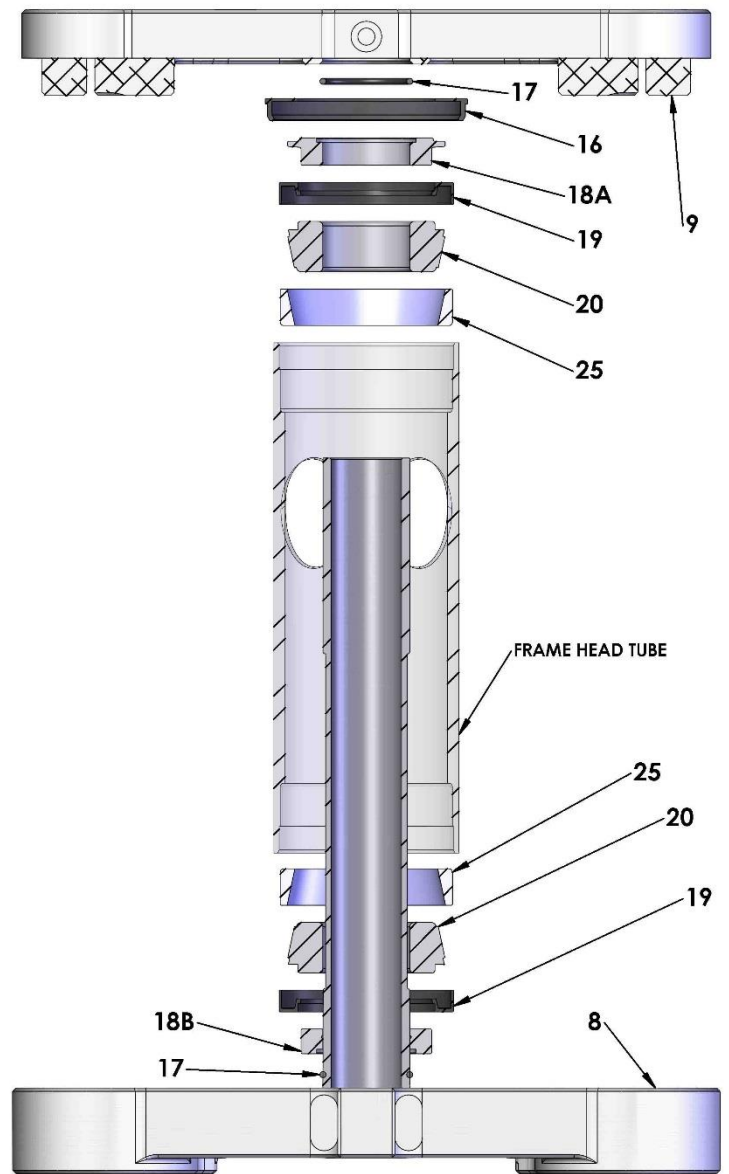
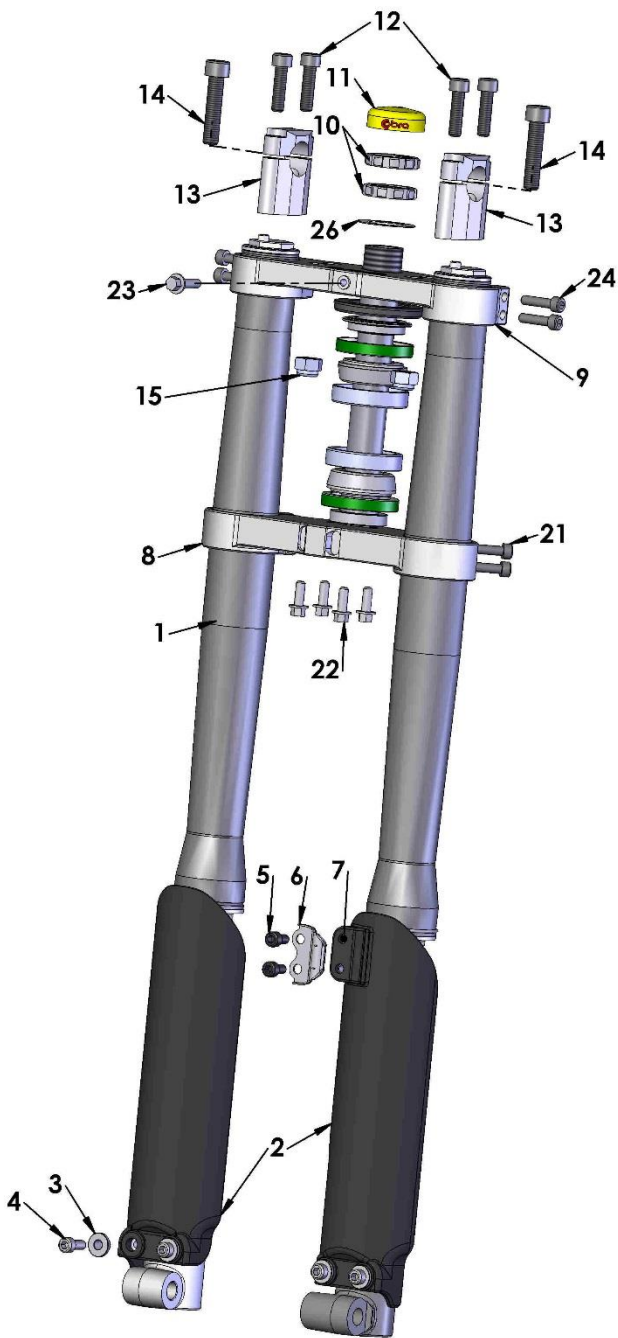

Front Forks and Triple Clamp		
REF #	PART #	DESCRIPTION
1	KACS2016FWE	FORK COMPLETE, BRAKE & NON-BRAKE SIDE
2	KCMU0011FLL	FORK GUARD SET
3	TCC60019	WASHER FORK GUARD (4 REQ'D)
4	HCBC0601	M6X16mm, SOCKET HEAD CAP SCREW (4 REQ'D)
5	BCC60015	BRAKELINE CLAMP
6	HCBC0612	M6X12mm, SOCKET HEAD CAP SCREW (2 REQ'D)
7	HCNL0601	M6 LOCKNUT (2 REQ'D)
8	FACS0007BLK	TRIPLE CLAMP BOTTOM ASSY, (CLAMP & STEM) BLACK
9	FCCS0053BLK	TRIPLE CLAMP TOP - BLACK
10	HCNJ0102	STEERING HEAD JAM NUT (2 REQ'D)
11	FCMU0151	CAP – STEERING STEM
12	HCBC0806	M8X30 SOCKET HEAD CAP SCREW (4 REQ'D)
13	TKMU0404BLK	BAR MOUNT KIT, SHORT (1 REQ'D) STANDARD - BLK
13A	TKMU0403	BAR MOUNT KIT, TALL
14	HCBC1001	M10X45mm SOCKET HEAD CAP SCREW (2 REQ'D)
15	HCNL1001	M10 LOCK NUT
16	FCMU1103	DUST COVER (1 REQ'D)
17	ZCMUOR35	O-RING (2 REQ'D)
18A	FCMU0038	SPACER – TOP
18B	FCMU0037	SPACER - BOTTOM
19	FCMU0039	SEAL (2 REQ'D)
20	FCMU0004	STEERING HEAD BEARING (2 REQ'D)
21	HCBC0603	M6X30mm SOCKET HEAD CAP SCREW (4 REQ'D)
22	HCBF0616	M6X16mm FLANGE HEAD BOLT (4 REQ'D)(FENDER MOUNTING)
23	HCBF0616	M6X16mm FLANGE HEAD BOLT (NUMBER PLATE MOUNTING)
24	HCBC0625	M6X25mm SOCKET HEAD CAP SCREW (4 REQ'D)
25	FCMU0011	STEERING HEAD RACE (2 REQ'D)
26	HCWS1015	SHIM WASHER – STEERING HEAD NUT
ACCESSORY	FKMU0006	KIT – STEERING STEM BEARINGS, RACES AND SEALS-2016-CUR

Parts – Forks – Leg Assembly – Brake Side

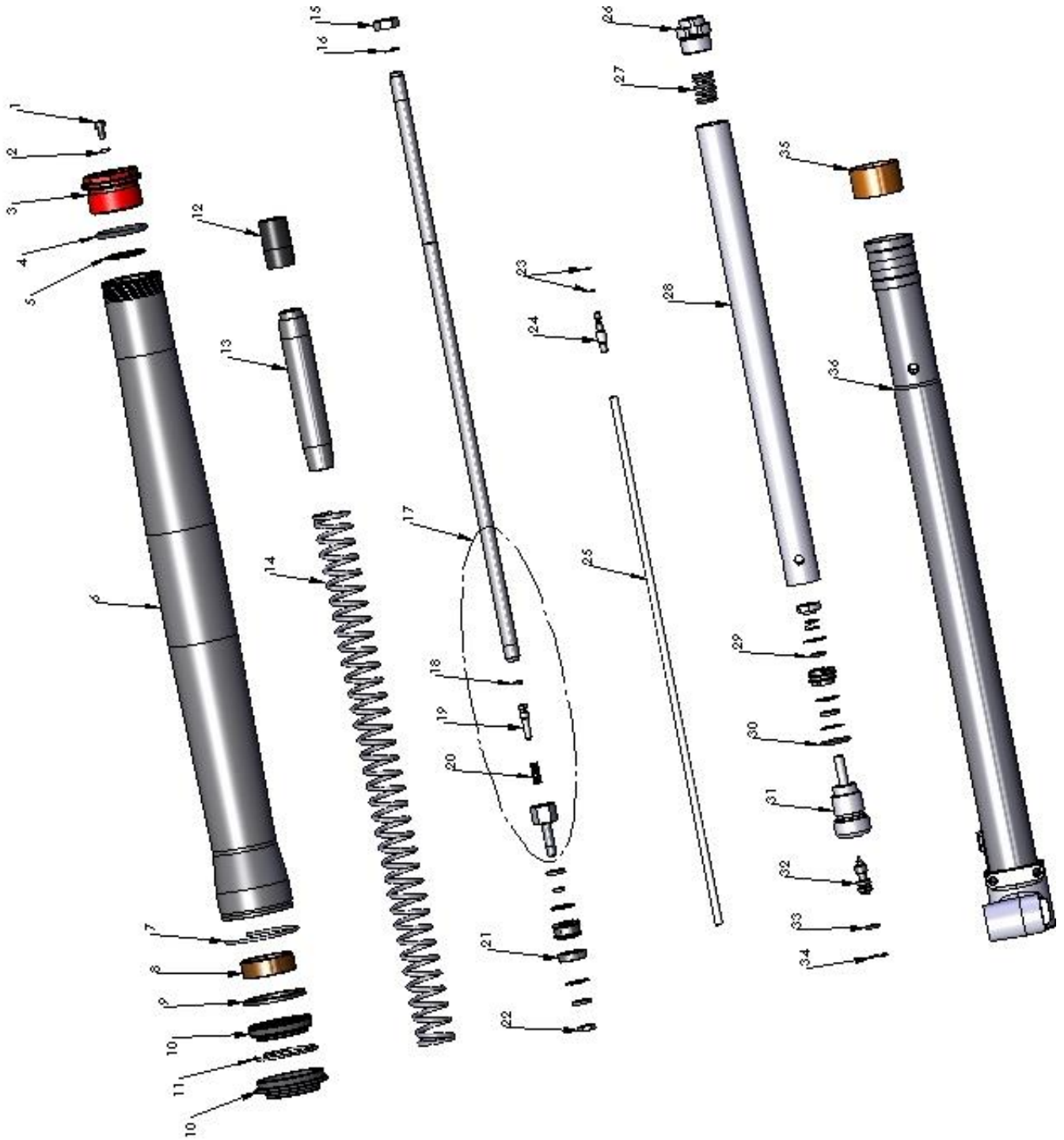

Parts – Forks – Leg Assembly – Brake Side

REF #	PART #	DESCRIPTION
1	HCBC0408	4 X 8 SHCS CLEAR ZINC
2	ZCKG0001	GASKET, BLEED SCREW FORK
3	KCCS0004C	FORK CAP - CONVENTIONAL 32MM USD
4	ZCMUOR18	O-RING – 3MM X 27MM ID
5	KCCS0036	SPRING WEAR PLATE 32MM
6	KCCS0005	OUTER TUBE 32MM
7	KCCS0035	RING CLIP FORK OUTER WEAR RING 32MM
8	KCCS0006	FORK GLIDE RING BOTTOM 32MM
9	KCCS0032	FORK SEAL SPACER 32MM
10	KKCS0004	FORK SEAL AND SWIPER KIT 32MM
11	KCCS0002	RING CLIP - FORK SEAL RETAINER - 32MM
12	KCC60067	FORK JOUNCE BUMPER
13	KCCS0013	FORK SPRING GUIDE 32MM
14	KCCS3225	STANDARD SPRING - FORK 0.25 KG/MM 32mm
14	KCCS3223	LIGHT SPRING - FORK 0.23 KG/MM 32mm
14	KCCS3227	HEAVY SPRING - FORK 0.257KG/MM 32mm
15	HCNJ3824	NUT JAM 3/8-24 CLASS 8
16	KCC60068	RING CLIP - FORK SPRING GUIDE RETAINER
17	KAC60003	DAMPER ROD ASSEMBLY
18	KCC60058	O-RING MID-VALVE ADJ NEEDLE
19	KCC60050	FORK MID-VALVE ADJUSTER NEEDLE
20	KCC60051	SPRING - FORK ADJUSTER NEEDLE
21	KCCS0018	SEAL - FORK PISTON - MID VALVE
22	HCNJ0601	6MM JAM NUT
23	BCKG0033	O-RING – 2MMID
24	KCCS0033	ADJUSTER SCREW TOP 32MM
25	KCC60049	ADJUSTER PIN
26	KCMU0013	CARTRIDGE CAP
27	KCKG0050	TOP OUT SPRING
28	KCKG0019	CARTRIDGE TUBE
29	KCMU0021	O-RING - FORK - BASE VALVE
30	ZCKGB017	O-RING - FORK BOTTOM PLUG
31	KCC60069	FORK BOTTOM PLUG – ADJUSTABLE
32	KCC60048	ADJUSTMET SCREW – FORK BOTTOM PLUG
33	ZCMUOR03	O-RING – ADJUSTMENT SCREW
34	KCCS0031	RING CLIP – FORK ADJUSTMENT SCREW
35	KCCS0007	FORK GLIDE RING
36	KAMU0001BLK	FOR LOWER – COMPLETE – BRAKE SIDE

Parts - Forks – Leg Assembly – Non-brake Side

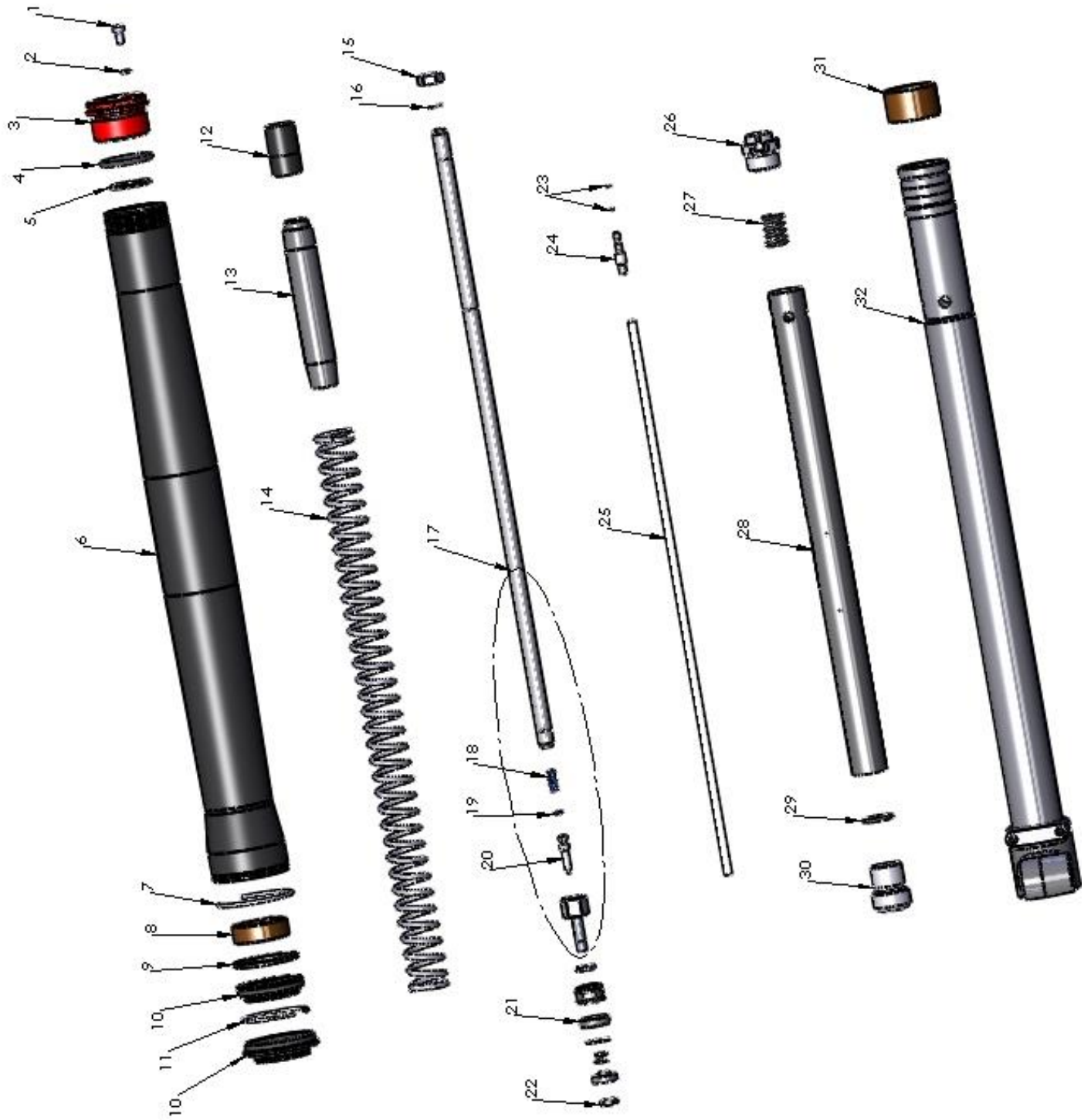

Parts - Forks – Leg Assembly – Non-brake Side

REF #	PART #	DESCRIPTION
1	HCBC0408	4 X 8 SHCS CLEAR ZINC
2	ZCKG0001	GASKET, BLEED SCREW FORK
3	KCCS0004S	FORK CAP - CONVENTIONAL 32MM USD
4	ZCMUOR18	O-RING – 3MM X 27MM ID
5	KCCS0036	FORK - SPRING WEAR PLATE 32MM
6	KCCS0005	FORK - OUTER TUBE 32MM
7	KCCS0035	RING CLIP FORK OUTER WEAR RING 32MM
8	KCCS0006	GLIDE RING BOTTOM 32MM
9	KCCS0032	SEAL SPACER 32MM
10	KKCS0004	FORK SEAL AND SWIPER KIT 32MM
11	KCCS0002	RING CLIP - FORK SEAL RETAINER - 32MM
12	KCC60067	FORK JOUNCE BUMPER
13	KCCS0013	SPRING GUIDE 32MM
14	KCCS3225	STANDARD SPRING - FORK 0.25 KG/MM 32mm
14	KCCS3223	LIGHT SPRING - FORK 0.23 KG/MM 32mm
14	KCCS3227	HEAVY SPRING - FORK 0.257KG/MM 32mm
15	HCNJ3824	NUT JAM 3/8-24 CLASS 8
16	KCC60068	RING CLIP - FORK SPRING GUIDE RETAINER
17	KAC60003	DAMPER ROD ASSEMBLY
18	KCC60058	O-RING MID-VALVE ADJ NEEDLE
19	KCC60050	FORK MID-VALVE ADJUSTER NEEDLE
20	KCC60051	SPRING - FORK ADJUSTER NEEDLE
21	KCCS0018	SEAL - FORK PISTON - MID VALVE
22	HCNJ0601	6MM JAM NUT
23	BCKG0033	O-RING – 2MMID
24	KCCS0033	ADJUSTER SCREW TOP 32MM
25	KCC60049	ADJUSTER PIN
26	KCMU0013	CARTRIDGE CAP
27	KCKG0050	TOP OUT SPRING
28	KCC60056	CARTRIDGE TUBE
29	KCMU0021	O-RING - FORK - BASE VALVE
30	KCC60057	PLUG – FORK BOTTOM – SMART LEG
31	KCCS0007	FORK GLIDE RING
32	KAMU0002BLK	FOR LOWER – COMPLETE – NON BRAKE SIDE

Parts – Frame I

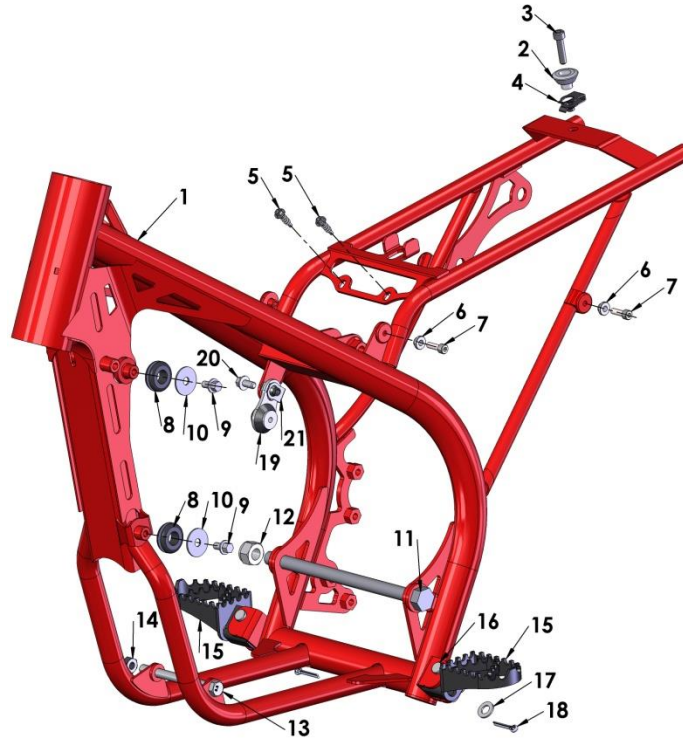

Frame		
REF #	PART #	DESCRIPTION
1	FACS2016FWE	FRAME KING – FACTORY WORKS EDITION
2	TCC60018	SEAT MOUNT SPACER
3	HCBC0625	M6X25mm SOCKET HEAD CAP SCREW
4	HCHA0003	6mm CLIP NUT (MOUNTS TO FENDER TO HOLD SEAT)
5	HCSP0003	PLASCREW AIRBOX MOUNTING (2 REQ'D)
6	TCC60017	WASHER – 5mm BODY PANEL (2 REQ'D)
7	HCBC0514	M5X14mm SHCS
8	MCC6GR01	GROMMET, RADIATOR MOUNTING (2REQ'D)
9	HCBF0616	M6X16mm FLANGE HEAD BOLT (2 REQ'D)
10	HCWF1478	FLAT WASHER (2 REQ'D)
11	HCBH1203	M12 SWINGARM PIVOT BOLT
12	HCNL1201	M12 SWINGARM LOCK NUT
13	HCBH0890	M8X90mm HEX HEAD BOLT
14	HCNL0801	M8 LOCK NUT
15	TAMU0005	FOOTPEGS (PAIR) (STANDARD)
16	FCMU0031	CLEVIS PIN - FOOTPEG
17	HCWF0801	8mm FLAT WASHER
18	HCCP0008	COTTER PIN 1/8 X 3/4
19	XCMU0033	ISOLATION MOUNT – EXHAUST
20	HCBF0616	M6X16mm FLANGE HEAD BOLT (2 REQ'D)
21	HCHA0003	6mm CLIP NUT
ACCESSORY	TCMU0139	ULTRAWIDE FOOTPEG KIT (PAIR) (UPGRADE)
ACCESSORY	TCMU0106	FOOTPEG SPRING (SINGLE PIECE)

Parts – Frame II

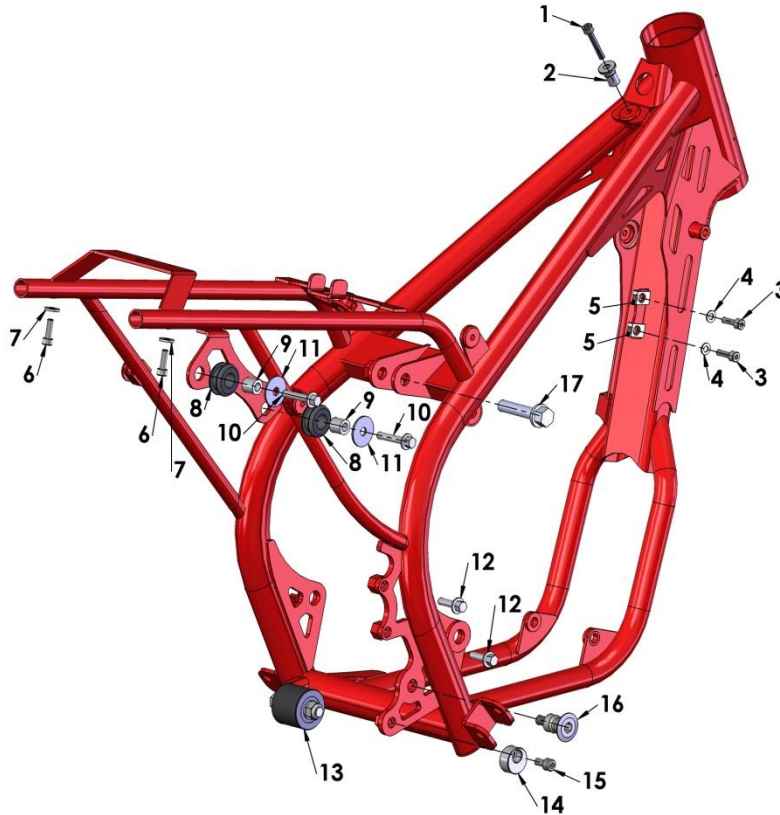

Frame		
REF #	PART #	DESCRIPTION
1	HCBC0503	M5X30mm SOCKET HEAD CAP SCREW FT TANK MOUNTING
2	TCC60027	SPACER – FT TANK MOUNTING
3	HCBC0516	M5X16mm SOCKET HEAD CAP SCREW (2 REQ'D)
4	HCWF0501	5mm FLAT WASHER (2 REQ'D)
5	HCCN0000	5mm CLIP NUT (MAY NOT BE USED)
6	HCBC0514	M5X14mm SOCKET HEAD CAP SCREW (2 REQ'D)
7	HCWP0002	WASHER - BODY PANEL FLAT (2 REQ'D)
8	MCMUGR03	MOUNTING GROMMET (2 REQ'D)
9	TCKG0001	SPACER (2 REQ'D)
10	HCBF0630	M6X30mm FLANGE HEAD BOLT (2 REQ'D)
11	HCWF1478	PIPE GROMMET WASHER (2 REQ'D)
12	HCBF0620	M6X20mm FLANGE HEAD BOLT (2 REQ'D)
13	FCC60020	CHAIN ROLLER W/BEAR & SEALS
13A	BCDC0153	WASHER (NOT SHOWN)
14	FCEX0018	BRAKE ADJUST ECCENTRIC
15	HCBC0612	M6X12mm SOCKET HEAD CAP SCREW
16	BCMU0027	BRAKE PIVOT BOLT
17	HCBF1040	M10X40mm HEX HEAD BOLT

Parts – Front Brakes

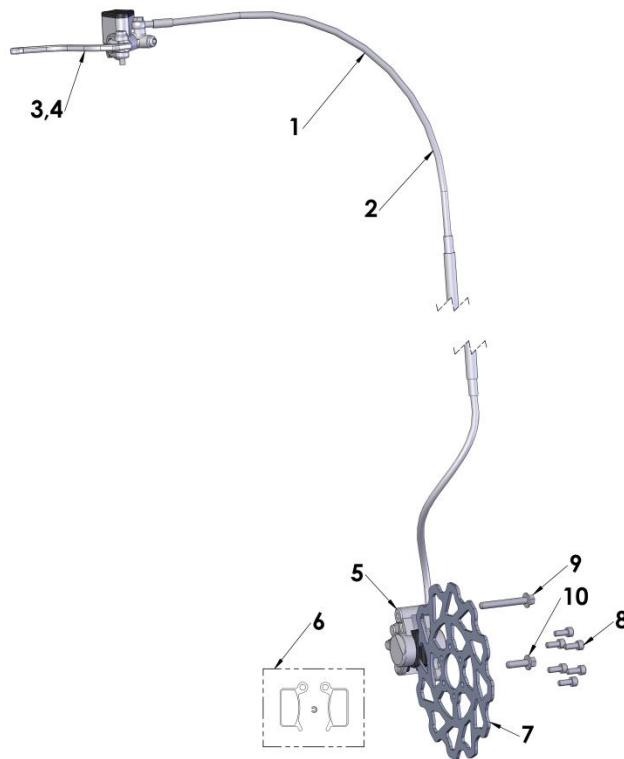

Front Brakes		
REF#	PART #	DESCRIPTION
1	BAKG0003	FRONT BRAKE ASSEMBLY
2	BCKG0030	HOSE – BRAKE FRONT
3	BCKG0023	ALLOY BRAKE LEVER
4	BCKG0024	BRAKE PERCH & MASTER CYLINDER ASSY W/ LEVER
5	BCKG0029	CALIPER – FRONT
6	BKKG0001	KIT BRAKE PADS, WITH “E” CLIP
7	BCMU0503	BRAKE ROTOR – 160mm
8	HCBC0514	M5X14mm SOCKET HEAD CAP SCREW (6 REQ'D)
9	HCBF0640	M6X40mm FLANGE HEAD BOLT
10	HCBF0620	M6X20mm FLANGE HEAD BOLT
ACCESSORY	MCMUBF02	BRAKE FLUID – BEL-RAY DOT 4 – 355 ml
ACCESSORY	BCKG0031	BLEED KIT (MULTIPLE SYRINGES, FITTINGS & HOSE)
ACCESSORY	BCKG0028	LEVER ADJUSTMENT KIT
ACCESSORY	BCKG0027	RESERVOIR SEAL KIT
ACCESSORY	BCKG0025	REPLACEMENT BAR CLAMP AND SCREWS (FOR MASTER CYLINDER)
ACCESSORY	BCKG0026	PISTON & REBUILD KIT FOR MASTER CYLINDER
ACCESSORY	BCKG0014	FITTING KIT FOR MASTER CYLINDER (BOLT, SET SCREW & O’RING)
ACCESSORY	BCKG0017	CALIPER ORING & BOLTS (F&R)
ACCESSORY	BCKG0018	CALIPER PISTON KIT (F&R)
ACCESSORY	BCKG0019	RETURN SPRING (4 FINGER SPRING)
ACCESSORY	ZCMUOR09	O’RING - BANJO FITTING
ACCESSORY	BCMU0014	CALIPER ADJUSTMENT SHIMS 6mm ID
ACCESSORY	BCKG0033	O-RING – BLEEDER – 2mm SPECIAL

Parts – Front Wheel

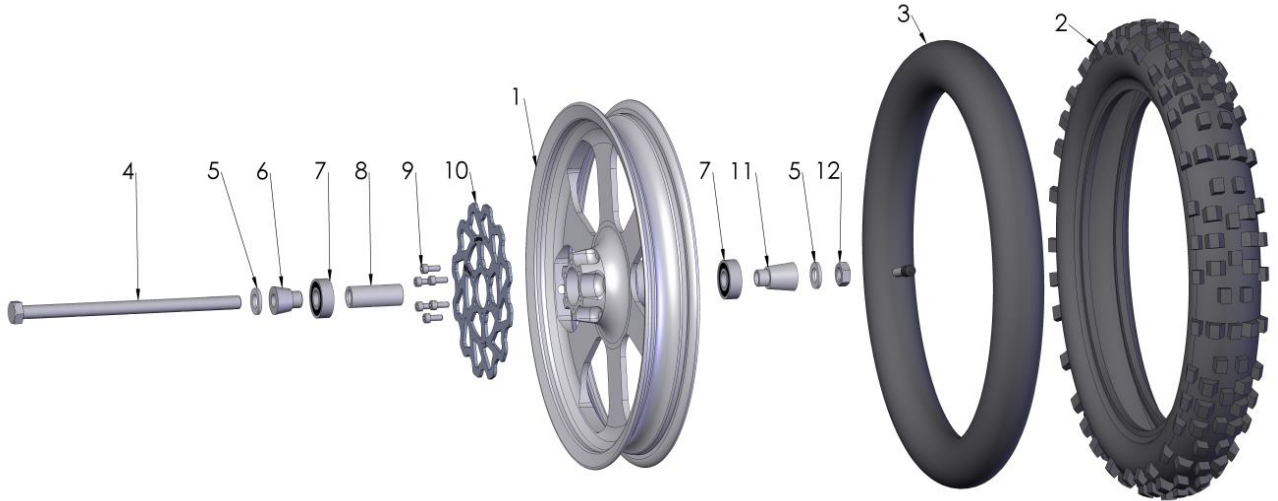

Front Wheel		
REF #	PART #	DESCRIPTION
1	WCKG0003BLK	FRONT WHEEL W/BEARINGS AND SPACER – BLACK ANODIZE
2	WCKG1200D	12" X 2.50 FRONT TIRE DUNLOP MX52
3	WCKG1201	12" FRONT TUBE
4	WCMU0016	FRONT AXLE
5	ECMU0040(T)	SHIM - OPTIONAL FOR BRAKE CALIPER ALIGNMENT
6	WCMU0101BLK	FRONT WHEEL SPACER, LARGE
7	WCMU0120	WHEEL BEARING (2 REQD)
8	WCMU0036	WHEEL BEARING SPACER
9	HCBC0501	BRAKE ROTOR MOUNTING BOLTS (6 REQ'D)
10	BCMU0503	BRAKE ROTOR
11	WCMU0123BLK	FRONT WHEEL SPACER, X LARGE
12	HCWF1202	FRONT AXLE WASHER
13	HCNL1201	FRONT AXLE NUT (12mm)

Parts – Plastic Bodywork & Seat

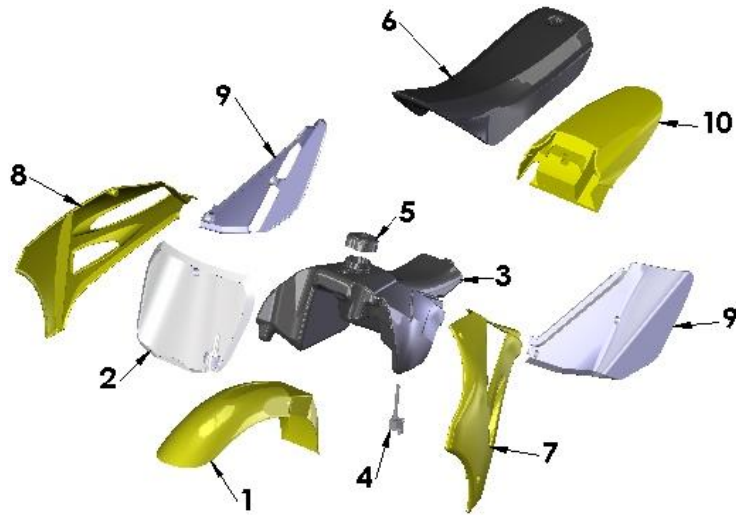

Plastic and Seat		
REF #	PART #	DESCRIPTION
1	TCMU0016FLL	FRONT FENDER - FLO YELLOW
1	TCMU0016x	FRONT FENDER x – DENOTES COLOR BLK, WHT, YEL, FLO
1A	HCBF0616	FRONT FENDER MTG BOLTS (4 REQ'D)
2	TCC60002W	FRONT NUMBER PLATE - WHITE
2	TCC60002x	FRONT NUMBER PLATE x – DENOTES COLOR BLK, WHT, YEL
2A	HCBF0612	M6X12mm FLANGE HEAD BOLT – FRONT NUMBER PLATE MOUNT
3	TCC60024	FUEL TANK (NO PETCOCK OR CAP)
3A	HCBC0503	M5X30mm SOCKET HEAD CAP SCREW – FRONT TANK MOUNTING
3B	TCC60027	SPACER – FRONT TANK MOUNTING
3C	TCC60029	SPACER – SEAT MOUNT
3D	HCFH0620	M6X20mm FLAT HEAD – FRONT SEAT MOUNT
4	TCMU0151	PETCOCK
5	TCHA0002	CAP – FUEL TANK
5A	TCHA0003	HOSE – FUEL CAP
6	TAFW0001	SEAT – FACTORY WORKS EDITION - CX50
6A	TCFW0001	COVER – SEAT – FACTORY WORKS EDITION CX50
6B	TCC60018BLK	SPECIAL WASHER – SEAT HOLDING - BLACK
6C	HCBC0625	M6X25 SHCS, REAR MOUNTING BOLT
7	TCC60022FLL	SHROUD LEFT – FLO YELLOW
7	TCC60022x	SHROUD LEFT x – DENOTES COLOR BLK, WHT, YEL, FLO
7A	TCC60017	BODY PANEL WASHER 5MM (1 REQ'D) – MT SHROUD TO RADIATOR
7B	HCBC0514	M5X14 SHCS (1 REQ'D) – MOUNT SHROUD TO RADIATOR
7C	HCCN0000	5MM EXTRUDED “U” NUT
7D	HCSP0004	PLASCREW – SHROUD TO TANK
8	TCC60023FLL	SHROUD RIGHT – FLO YELLOW
8	TCC60023x	SHROUD RIGHT x – DENOTES COLOR BLK, WHT, YEL, FLO
8A	HCSP0004	PLASCREW – SHROUD TO TANK (2 REQ'D)
9	TCCS0001WHT	NUMBER PLATE PAIR - WHITE
9	TCCS0001x	NUMBER PLATE PAIR x – DENOTES COLOR BLK, WHT, YEL
9A	HCBC0514	M5X14 SOCKET HEAD CAP SCREW (2 REQ'D PER SIDE)
9B	TCC60017	BODY PANEL WASHER 5MM (2 REQ'D PER SIDE)
9C	HCCN0000	5MM EXTRUDED “U” NUT
10	TCCS0005FLL	REAR FENDER – FLO YELLOW
10	TCCS0005x	REAR FENDER x – DENOTES COLOR BLK, WHT, YEL, FLO
10A	HCSP0004	PLASCREW (2 REQ'D) – FENDER TO AIRBOX - 2016
10B	HCBC0514	M5x14 SOCKET HEAD CAP SCREW (2 REQ'D)
10C	HCWP0002	WASHER - BODY PANEL FLAT (2 REQ'D)
10D	HCHA0003	CLIP NUT – 6mm
ACCESSORY	TCFW2016	GRAPHIC KIT – CX50 FEW 2016
ACCESSORY	TKCS0001B	BODYWORK KIT - 2010 & NEWER KING - BLACK
ACCESSORY	TKCS0001W	BODYWORK KIT - 2010 & NEWER KING - WHITE
ACCESSORY	TKCS0001Y	BODYWORK KIT - 2010 & NEWER KING - YELLOW

Parts – Rear Brake

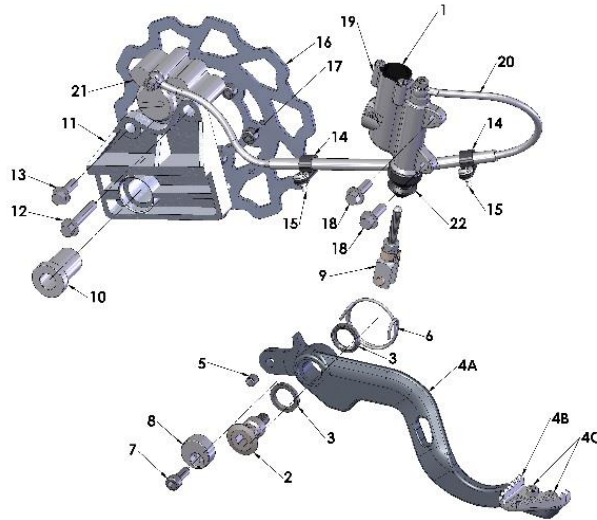

Rear Brake System		
REF #	PART #	DESCRIPTION
1	BAKG0002	BRAKE SYSTEM – REAR (M/C-LINE-CALIPER)
2	BCMU0027	BRAKE PIVOT BOLT
3	BCMU0501	SEAL – BRAKE PEDAL (2 REQ'D)
4A	BCMU0029	BRAKE PEDAL – ASSEMBLY 50cc – WITH TOE PIECE
4B	BCMU0023T	TOE PIECE
4C	HCBC0501	M5X 12mm SOCKET HEAD CAP SCREW
5	BCDCBU01	BUSHING REAR BRAKE PEDAL
6	BCMUSP02	BRAKE RETURN SPRING
7	HCBC0601	M6X16mm SOCKET HEAD CAP SCREW
8	FCEX0018BLK	BRAKE ADJUST ECCENTRIC - BLACK
9	BAC60004	PUSH ROD, REAR BRAKE
10	BCKG0006	WHEEL SPACER - FLOATING CARRIER
11	BCKG0103	BRAKE CARRIER
12	HCBF0635	M6X35 FLANGE HEAD BOLT
13A	HCBF0620	M6X20 FLANGE HEAD BOLT
14	HCCC0000	BRAKE HOSE CLAMP (2 REQ'D)
15	HCPP0832	BRAKE HOSE CLAMP FASTENER (2 REQ'D)
16	BCMU0502	BRAKE ROTOR – 140mm
17	HCBC0601	M6X16mm SOCKET HEAD CAP SCREWS (5 REQ'D)
18	HCBF0620	M6X20mm FLANGE HEAD BOLT (2 REQ'D)
19	BCKG0012	BRAKE – MASTER CYLINDER - REAR
20	BCKG0010	REPLACEMENT BRAKE HOSE
21	BCKG0013	CALIPER – REAR BRAKE
22	BCMU0022	BRAKE – RUBBER CAP
ACCESSORY	BKKG0001	BRAKE PADS WITH “E” CLIP
ACCESSORY	BCKG0031	BLEED KIT (MULTIPLE SYRINGES, FITTINGS & HOSE)
ACCESSORY	BCKG0014	FITTING KIT – W BANJO BOLT
ACCESSORY	BCKG0015	MASTER CYLINDER PISTON / SEAL KIT
ACCESSORY	BCKG0016	RESERVOIR SEAL KIT
ACCESSORY	BCKG0017	CALIPER BOLT / O-RING KIT
ACCESSORY	BCKG0018	CALIPER PISTON / SEAL KIT
ACCESSORY	BCKG0019	PAD RETURN SPRING (4 LEG SPRING)
ACCESSORY	ZCMUOR09	O-RING - BANJO FITTING
ACCESSORY	BCKG0033	O-RING – BLEEDER – 2mm SPECIAL

Parts – Rear Wheel

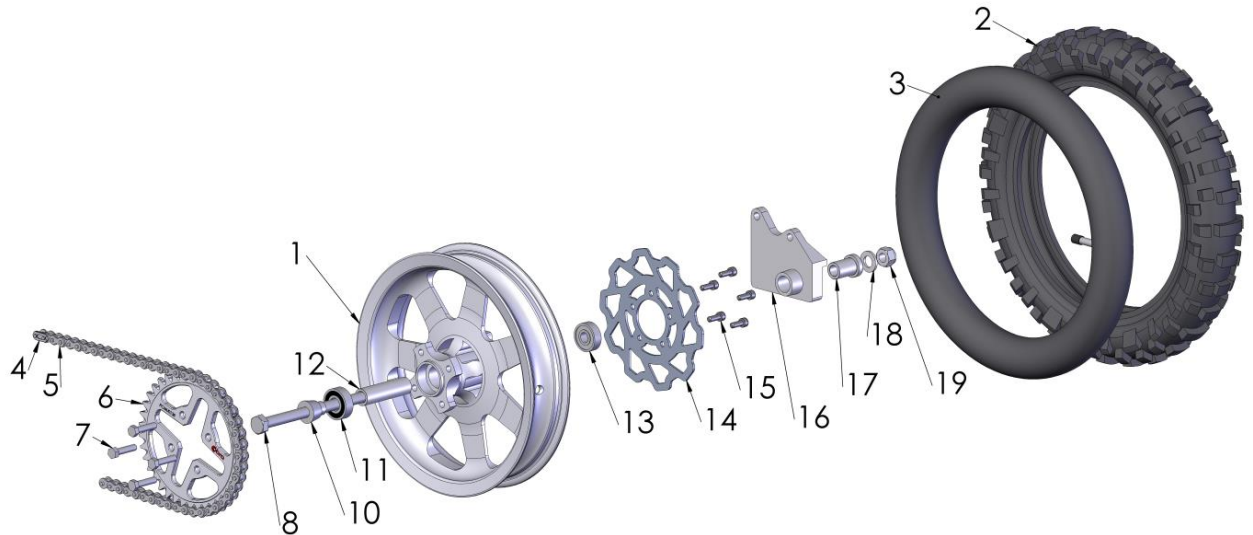

Rear Wheel		
REF #	PART #	DESCRIPTION
1	WCKG0016BLK	REAR WHEEL W/BEARINGS AND SPACER – BLACK ANODIZE
2	WCMU1075D	TIRE – REAR 10X2.75” DUNLOP MX52
3	WCMUTU10	TUBE, 10"
4	PCMU0001	MASTER LINK 420
5	PCMU0100	CHAIN 420 X 100
6	PCMU0238	38T SPOCKET 415 BLACK (STANDARD)
	PCMU01xx	SPOCKET - xx denotes number of teeth (35-45)
	PCMU0y38	SPOCKET – y denotes width (1 = 420, 2 = 415)
7	HCBH0702	M7X30mm HEX HEAD BOLT
7A	HCWF0701	7mm FLAT WASHER (4 REQ'D)
7B	HCNL0701	M7 LOCKNUT (4REQ'D)
8	WCMU0016	REAR AXLE
10	WCMU0101BLK	WHEEL SPACER - BLACK
11	WCMU0120	WHEEL BEARING SPROCKET SIDE
12	WCMU0035	WHEEL BEARING SPACER
13	WCMU0020	WHEEL BEARING BRAKE SIDE
14	BCMU0502	BRAKE ROTOR – 140mm
15	HCBC1616	M6X16mm SOCKET HEAD CAP SCREWS (5 REQ'D)
16	BCKG0103	BRAKE CARRIER
17	BCKG0006	WHEEL SPACER - FLOATING CARRIER
18	HCWF1202	12mm AXLE WASHER
19	HCNL1201	M12 AXLE NUT

Parts – Shock

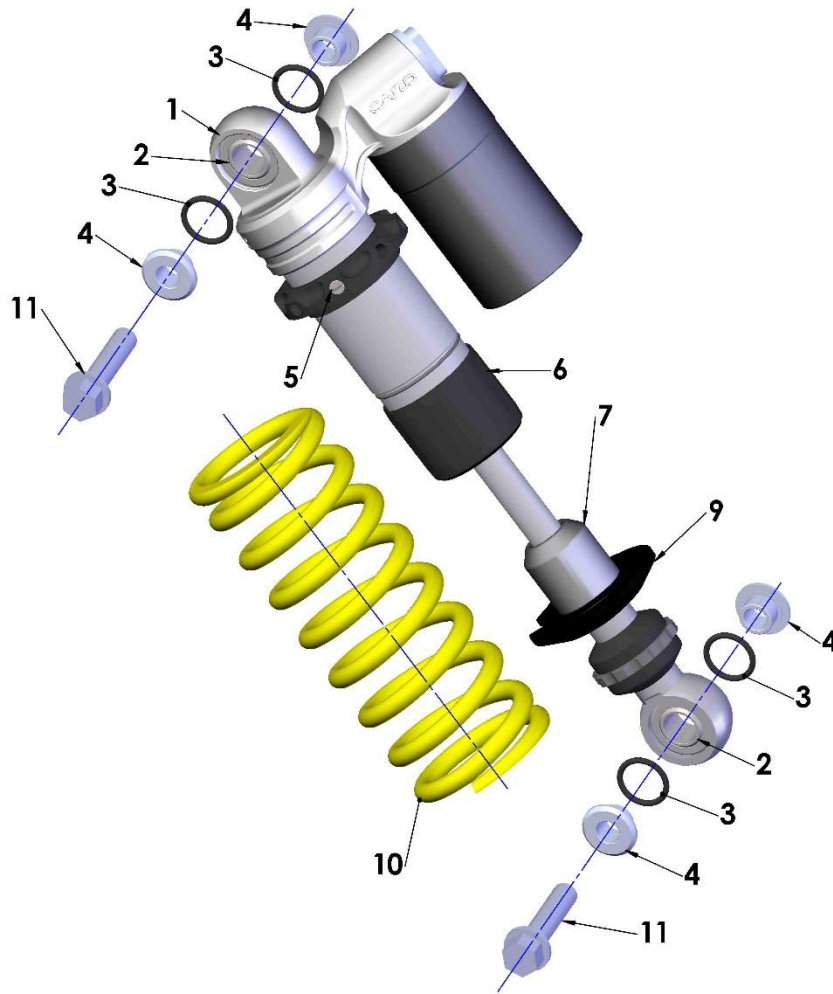

Shock		
REF #	PART #	DESCRIPTION
1	SACS2016	SHOCK ABSORBER – KING
2	SCMU0043	SHOCK - BEARING SPHERICAL SHOCK MOUNT-CARD (2 REQ'D)
3	SCMU0039	O-RING - SHOCK - BUSHING – CARD (4 REQ'D)
4	SCMU0042	SHOCK - MOUNT BUSHING – CARD (4 REQ'D)
5	SCMU0058	SHOCK - WHITE NYLON TIP SETSCREW M6-1.0 - CARD
6	SCMU0056	SHOCK - SLEEVE BLACK - CARD
7	SCMU0100	BUMPER - TAPPERED - SHOCK
8	SCMU0040	SHOCK - SPRING PAD - CARD
9	SCMU0054	SHOCK - SPRING PERCH - CARD
10	SCKGFX37	SHOCK SPRING 3.7 KG/MM (STANDARD)
10	SCKGFX35	SHOCK SPRING 3.5 KG/MM (LIGHT)
10	SCKGFX39	SHOCK SPRING 3.9 KG/MM (HEAVY)
11	HCBF1040	M10 X 40 HEX HEAD BOLT (2 REQ'D)
ACCESSORY	SKMU0003	REBUILD KIT – CARD SHOCK - 2016

Parts – Shock - Inside

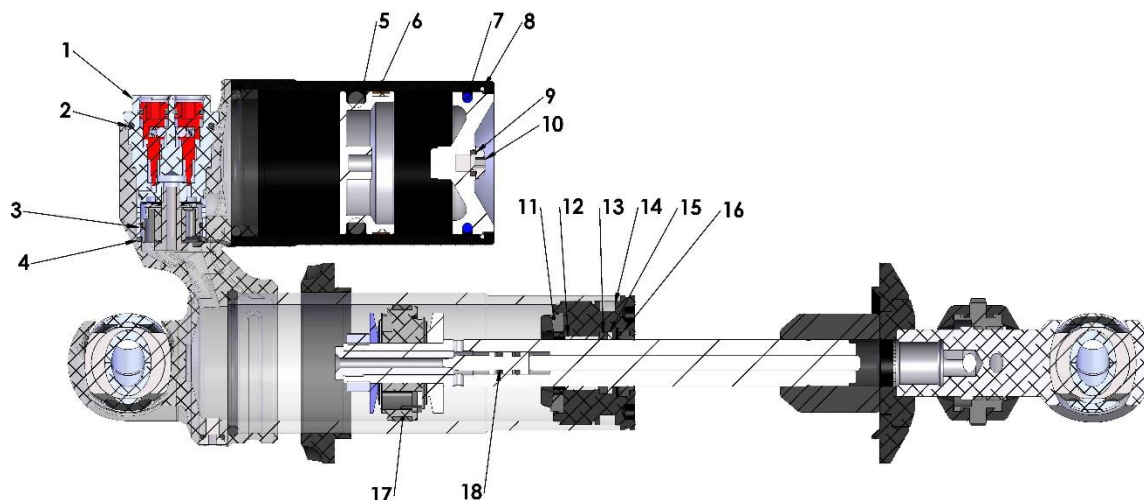

Shock		
REF #	PART #	DESCRIPTION
1	SAMU0001	COMPRESSION ADJUSTER ASSEMBLY – COMPLETE
2	ZCMUB020	O-RING – COMPRESSION ADJUSTER - OUTSIDE
3	KCMU0021	O-RING - COMPRESSION ADJUSTER – PISTON SEAL
4	ZCMUOR37	O-RING - COMPRESSION ADJUSTER - INSIDE
5	SCMU0051	O-RING - IFP
6	SCMU0052	IFP SEAL BAND
7	SCMU0033	O-RING SHOCK BASE
8	SCMU0050	RESERVOIR CAP RETAINER RING
9	SCMU0035	O-RING CHARGE CAP
10	HCBB0506	M5X6mm LONG BUTTON HEAD STAINLESS STEEL
11	SCMU0044	SEAL HEAD BUMPER
12	SCMU0048	SHAFT BUSHING
13	SCMU0046	X-RING SEAL
14	SCMU0034	O-RING SEAL HEAD
15	SCMU0047	SPACER - X-RING
16	SCMU0045	DUST SEAL
17	SCC60014	PISTON BAND
18	SCMU0059	O-RING REBOUND PIN
ACCESSORY	SKMU0003	REBUILD KIT – CARD SHOCK - 2016

Parts – Swingarm Assembly

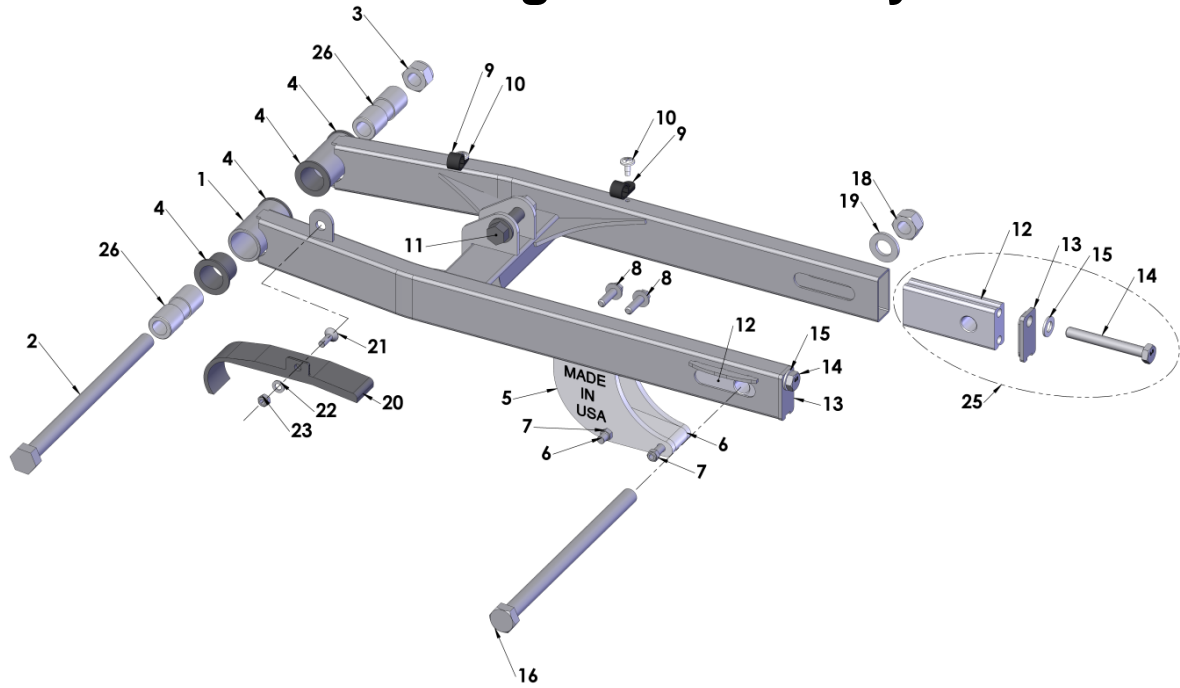

Swingarm		
REF #	PART #	DESCRIPTION
1	GACS2010	SWINGARM
2	HCBH1203	M12 SWINGARM PIVOT BOLT
3	HCNL1201	M12 SWINGARM LOCK NUT
4	GCMU0001	SWINGARM BUSHING (4 REQ'D)
5	PAFW0001	CHAIN GUIDE ASSEMBLY COMPLETE – FACTORY WORKS EDITION
6	HCBFT640	M6X40mm FLAT HEAD SCREW (2 REQ'D)
7	HCNL0601	M6 LOCKNUT (2 REQ'D)
8	HCBF0620	M6X20mm FLANGE HEAD BOLT (2 REQ'D)
9	HCCC0000	CLAMP – BRAKE HOSE (2 REQ'D)
10	HCPP0832	FASTNER - HOSE CLAMP (2 REQ'D)
11	HCBF1040	M10X40mm LOWER SHOCK MOUNT BOLT
12	FCMU0203	WHEEL PULL
13	FCMU0202	WHEEL PULL ENDCAP
14	HCBH0810	M8X65mm WHEEL PULL BOLT
14A	HCWL0801	8mm LOCK WASHER
15	HCWF0801	8mm WHEEL PULL WASHER
16	WCMU0016	REAR AXLE
18	HCNL1201	M12 AXLE NUT
19	HCWF1202	AXLE WASHER
20	GCMU0017	TOP CHAIN SLIDE
21	HCFH0516	FLAT HEAD SCREW
22	HCWF0501	WASHER
23	HCNL0501	LOCK NUT
24	PCKG0004	BOTTOM CHAIN SLIDER
25	FAMU0005	WHEEL PULL ASSEMBLY (BLOCK, CAP, BOLT AND WASHER)
26	GCCS0001	SWINGARM PIVOT TUBE SPACER (2 REQ'D)

Service

Trained technicians with precision gauging and proper assembly fixtures carefully assemble all Cobra engines to specific tolerances. If you feel you have the skills, and the appropriate tools, to perform the following service tasks please follow the instructions closely. The part numbers are listed throughout to help you when ordering parts from your local Cobra dealer.

If you don't feel comfortable with the service work, log on to www.cobramoto.com to find a Cobra dealer or Call 517 437 9100.

Engine Service

One method for determining whether the top end of your engine needs rebuilt is to perform a WOT (Wide Open Throttle) kicking compression test. Before performing the procedure please read the caution notes below.

CAUTION:

- There appears to be a wide range of variability in reading compression gauges across the country.
- The head volume of this Cobra Motorcycle is very small and so requires many kicks ~20 before you establish the most accurate reading possible.
- Because of the geometry of the spark plug used in this Cobra Motorcycle, the adapter used with your compression tester must have a similar volume protruding into the combustion chamber to establish an accurate value.
- Length of hose on the compression tester will affect the reading. The shorter the hose length the more accurate your reading will be.

Because of these difficulties in measuring an *absolute* compression value, a useful *relative* value can be achieved by testing your bike's compression with your own particular gauge after a new top end or when the bike is new so that you know what your particular gauge reads on a 'fresh' engine. When it has dropped to 90% of its original value the engine will be down on power and would benefit from a rebuild. When it's dropped to 80% it really needs rebuilt! Using the table below will help you determine monitor the condition of your top end.

	Engine is Fresh Measured Value	Engine Down on Power Measured Value * 0.9	Engine NEEDS Rebuilt Measured Value * 0.8
Example	110 psi	110 psi * 0.9 = 99 psi	110 psi * 0.8 = 88 psi
Your Values			

Procedure for Compression Testing

1. Shut off the fuel petcock.
2. Install the compression gauge into the spark plug hole.
3. Hold the throttle to wide open, and kick repeatedly (approximately 20 times) or until the gauge reading does not increase in value with each kick.

Base Gasket Selection

Tools required

- 17mm wrench
- 1mm flexible solder material
- measurement calipers

When rebuilding the ‘top end’ of your Cobra motorcycle, care must be taken to ensure the proper squish clearance. Squish clearance is defined as the minimum distance between cylinder head and piston at TDC, and there are negative effects of either having too much or too little clearance. Since parts like the crank, connecting rod, cylinder head, piston, and crankcases all have varying tolerances, Cobra offers several different base gasket thickness’ to ensure that you can always set the squish clearance of your engine to factory specifications.

For base gasket replacement use the code (see figure 21 for location) along with the table on the following page reorder the correct thickness gasket.



Figure 21

Code	Supplied Base Gasket Thickness		Cobra #
	#	mm	inch
	0.25	0.010	ZCMU0011
3	0.3	0.012	ZCMU0703
4	0.4	0.015	ZCKG0501
5	0.5	0.020	ZCMU0705
6	0.6	0.024	ZCMU0706
7	0.7	0.028	ZCMU0707
8	0.8	0.031	ZCMU0708
1	1.0	0.039	ZCMU0016

NOTE: Tolerances will affect the actual gasket thicknesses.

If during the course of the maintenance more parts than the base gasket are changed, the squish clearance should be measured, and possibly a different base gasket will be required.

The easiest way to measure squish clearance is with 1mm to 1.5mm thick flexible solder wire (available through most popular electronic stores). The process is as follows:

- Assemble the top end of the engine with either; 1) the crankcase stamp recommended base gasket or, 2) if assembling with a new set of cases assemble with a 0.4mm (0.015") base gasket, and torque the head nuts to the proper torque specifications leaving off the spark plug and ignition cover (piston rings can be left off to ease of assembly).
- Carefully insert the solder wire through the spark plug hole, into the cylinder far enough such that the tip of the wire touches the left or right side cylinder wall (not the front or back as the piston will rock more and give incorrect measurement).
- Hold the wire at this position and rotate the crankshaft, by the flywheel nut (or kick lever) three revolutions to crush the solder wire.

CAUTION:

If you rotate the flywheel nut in a counterclockwise direction there is a risk of loosening the nut.

- Pull out the wire and measure the solder thickness at the thinnest location near its tip accurately with the thin tips of calipers.
- Adjust base gasket thickness as necessary to get the desired value.

Upon completion, your final assembly squish clearance should agree with the chart below:

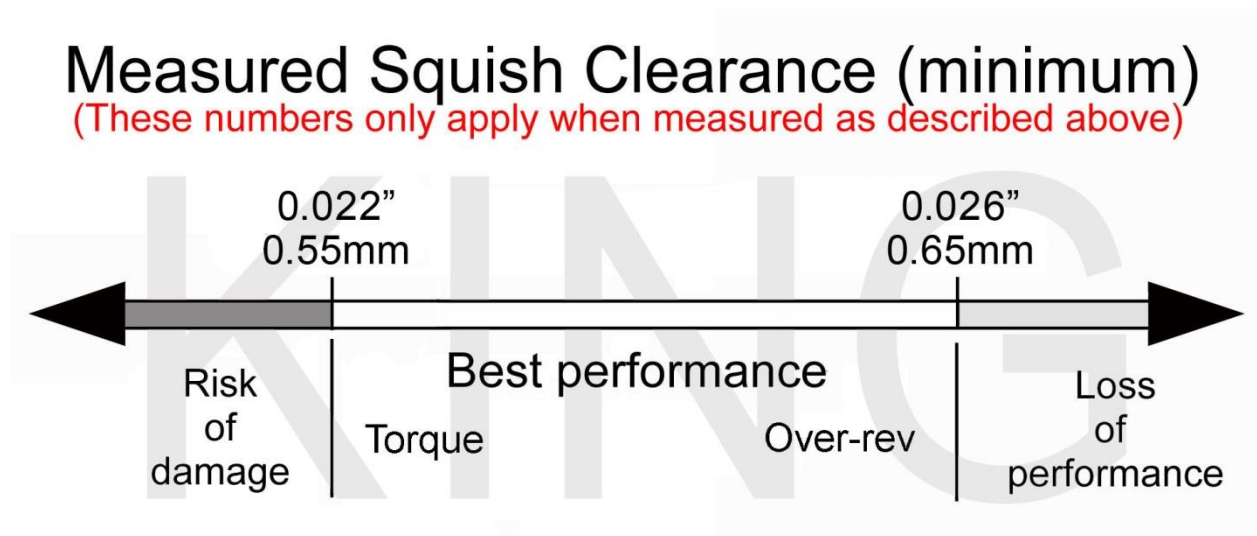

CFD Adjustment

This section tells you what to do if you have tested and determined that the CFD requires adjustment.

Tools required

- 5mm & 10mm hex key
- Pliers to remove the old cotter key
- A new cotter key (Cobra MIL spec recommended – Hardware store ones will become brittle from the hot oil and randomly fail)
- 19mm socket
- Cobra gear stop tool (EAMU0004)

Procedure

1. Drain the oil into a suitable container for recycling (10mm hex key)
2. Remove the clutch side cover (5mm hex key)
3. Remove the cotter pin from the castle nut in the CFD assembly.
- 4.

NOTE:

The CFD castle nut is “left hand thread”. Turn it counter clockwise (anti-clockwise for you Europeans) to tighten it.

5. Tighten the castle nut to the next cotter pin assembly location.
6. With the internal CFD gear stop tool in position check the slip torque again (it is NOT necessary to have the cotter pin for the test)
7. If the slip torque is below 108 Nm (80 ft-lb) then repeat steps 5 and 6 above.
8. Once the slip torque is at the desired value, install the cotter pin as shown.
9. Remove the CFD gear stop tool
10. Reinstall the clutch cover
11. Fill the clutch case with 250cc Clutch Milk and the bike is ready to race

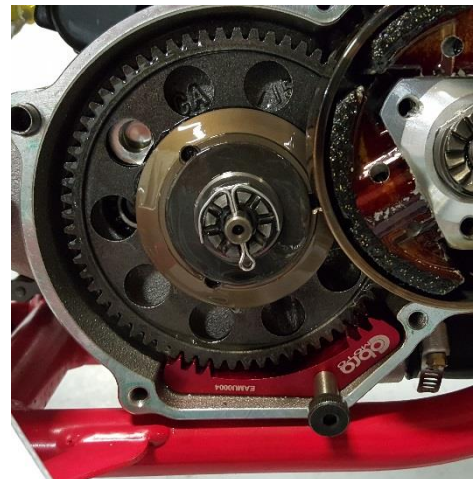

Engine Removal

To service the bottom end and transmission, the engine must be removed from the frame.

Tools required

- 10, 11, 13, 22 mm wrench
- 8, 10, 14, 17 & 19 mm sockets
- 3, 4 & 5 mm hex key
- 7 mm nut driver, flat or Phillip, screwdriver for hose clamps
- Spring remover
- Flywheel / clutch puller (#MCMUTL70)
- Clutch nut removal tool (#ECMU0078)
- CFD gear stop (#EAMU0004)

Procedure

1. Remove the seat.
2. Turn of the fuel at the petcock and disconnect the fuel line.
3. Remove the tank (8 mm socket).
4. Remove the carburetor from the inlet (flat head or Phillips head screwdriver, 7 mm nut driver).
5. Remove the silencer & pipe (spring remover, 8mm socket).
6. Locate a suitable container for the engine coolant and disconnect the coolant lines connected to the engine (8 mm socket).

NOTE: If the coolant looks to be free of contaminates it may be reused.

7. Remove the master link from the chain.
8. Remove front engine mount bolt (13 mm socket, 6 mm hex key).
9. Remove the swingarm bolt (19mm socket).

NOTE: Only drive the swingarm bolt far enough to clear the engine, leave it holding the one side of the swingarm to the frame

10. Remove the engine from the right side of the frame.

NOTE: If you are merely performing a top end service skip ahead to *Top End Disassembly Procedure*.

Complete Engine Disassembly Procedure

1. Remove the ignition cover (3mm hex key)
2. Remove the bolt from the water pump shaft (4mm) and slide off the belt cover and the water pump belt
3. Using a flywheel holding tool and 14 mm socket remove the nut that secures the flywheel.
4. Using the Cobra flywheel / clutch puller (#MCMUTL70), remove the flywheel from the crankshaft.

5. Remove the stator (4mm hex key).
6. Remove the clutch nut / starter gear that holds on the clutch (#ECMU0078).
7. With the Cobra flywheel / clutch puller (#MCMUTL70), remove the clutch from the crankshaft (details in Clutch Service portion of this manual).
8. Remove the **left hand thread** nut holding the CFD to the transmission input shaft using the CFD gear stop (#EAMU0004) and a 19mm socket.

Top End Disassembly Procedure

1. Remove the cylinder head nuts (10mm).
2. Remove the cylinder head outer.

INSPECTION NOTE:

Inspect the cylinder head for deposits and abrasions.

1. If there are deposits they should be removed
 - a. Black oily deposits (indicating a rich mixture or improper oil type/quantity) can be removed with solvent
 - b. Crusty deposits (indicating dirt ingestion) can be removed with solvent and may require some scraping.
2. Abrasions
 - a. Pitting or erosion indicates detonation and may require cylinder head replacement, also
 - i. Retard the ignition timing
 - ii. Use a higher octane fuel
 - b. Missing chunks or indentations indicate broken hardware or ingested items - replace the cylinder head.

3. Remove the cylinder head insert.
4. Remove the cylinder.

INSPECTION NOTE:

Inspect the cylinder bore for abrasions, deposits, and missing coating.

1. If abrasions: scrapes, scratches, pitting, etc... are found, replace the cylinder.
2. If deposits are all are found
 - a. Clean with muriatic acid.
 - b. Once the deposits are removed, inspect for abrasions and missing surface coating.
 - i. If there are abrasions or missing coating, replace.
 - ii. If all looks well, the cylinder may be saved.

WARNING

Muriatic acid can be dangerous. Follow the manufacturer's instructions closely.

5. Remove the piston clip with a scribe.
6. Remove the piston pin with a piston pin remover.

INSPECTION NOTE:

Inspect the piston for abrasions and deposits on the top and sides and clean or replace as necessary.

INSPECTION NOTE:

Piston ring end gap should be between 0.006" (0.16 mm) and 0.020" (0.5 mm)

Splitting the Cases

1. Remove the fasteners holding the two halves of the crankcase together.
2. Separate the cases with a proper case splitting tools.

CAUTION:

Take caution when handling the crankshaft. It is the main power transfer to the rest of the engine. If it is out of alignment, it will cause premature failure of your bearings which can lead to serious damage to the cylinder as well as the rest of the engine. Do not try to true the crank yourself. Truing the crank should be done professionally.

CAUTION:

- If you split the cases, check the gear tooth faces for chipping & signs of fatigue.
- Check all the bearing for smooth noise free operation.

Engine assembly

CAUTION:

For any seals that are to be installed, apply a light amount of grease to the seals' ID, assembly lube on all bearings and a small amount of Loctite to the OD.

1. Press the three bearings into the respective holes in each case half.
2. Press in the crank seals such that the concave side faces the crank weights.
3. Press in the counter shaft seal (concave side faces inside of transmission)
4. Press in the water pump assembly
5. Tap both ways axially then verify easy rotation.
6. Inspect the crankshaft for proper true geometry (no more than 0.002 ", 0.05mm, measured at bearing journal area while supported from the ends).
7. Insert the case bolts with the proper lengths at locations shown.
8. Torque to 12Nm (105in-lb). Starting toward the center working outward.
9. Trim away any excess gasket material if necessary.

NOTE: Check engine mount holes for excess material that may cause problems in engine installation.

10. Install the piston with new wrist pin bearing and, pin and clips.

CAUTION:

Be sure to install the piston such that the arrow on the top piston surface points to the exhaust (front of bike/engine) and put assembly lube on the connecting rod bearing.

11. Install the piston rings.

CAUTION:

Ring end gap should be no less than 0.006" (0.016mm) and no more than 0.020" (0.5mm).

12. Install the base gasket.

CAUTION:

See base gasket selection at the beginning of service section.

13. Install the cylinder being sure that the piston rings are properly aligned with the indexing pins.

CAUTION:

Never force the cylinder. If resistance is felt, determine the problem and solve it. Once installed slightly rotate the cylinder back and forth insuring that the rings are properly seated.

14. Install cylinder head insert.

NOTE: A light application of silicone grease can help hold the O-rings into position during assembly.

15. Install O-RINGS as shown in the Parts-Engine Top End page.

16. Install the cylinder head.

17. Install the flange nuts. Torque to 123 in-lb (14 Nm)

18. Install reed and intake manifold with new gasket. Torque to 55 in-lb. (6.2 Nm).

CAUTION:

The intake manifold bolts will require being checked and torque values reset after a few heat cycles.

19. Leak check the engine to 20 psi to ensure proper seal.

20. Install stator reinstalling the grommet and wires (snug the bolts).

21. Install the rotor per *Rotor Installation* section, under the *S3: Ignition* portion of this manual.

22. If necessary install the water pump outlet pipe (apply gray Permatex gasket maker to the threads before assembly).

23. Install the CFD.

24. Install the clutch per *Clutch Installation* section in this manual.

25. Install the coolant drain plug.

26. Make sure that the exhaust spacer is on the cylinder (53 in-lb, 6 Nm).

27. Install the spark plug with a fresh gasket (to apply the proper torque to the spark plug when inserting, one must first screw the spark plug in until the metal gasket ring causes resistance and then turn another 1/8 to 1/4 turn).

Clutch

The sleeve bolts of the 5GX provide a low uniform stress, minimal heat transfer, and allow channels for flushing the clutch fibers out of the washer stacks allowing a long time between part replacement provided you operate with 10 oz of clean Clutch Milk.

All washer stacks are double sorted at the factory. They are first sorted by measured height. Secondly, each stack with bolt is sorted by measured engagement force. The stacks in each set of three will measure within 0.05mm (0.002").

There are many variables in an automatic centrifugal clutch. These variables are set to world class standards from the factory but will change over time as the components wear, relax, and just plain get used.

Please see the Tuning Clutch portion of this manual for more helpful info.

Tools recommended for clutch service:

- Universal clutch puller- a universal puller that pulls the clutch, main drive gear and rotor. (Part # MCMUTL70).
- 5mm T-handle
- T25 Torx
- Accurate torque wrench in the range of 16 Nm (12 ft-lb, 144 in-lb).
- Clutch nut removal tool (ECMU0078) & piston stop (MCMUTL03).
- *Cobra 3 Shoe Clutch Milk* (Part # MCMUGF32).

CLUTCH REMOVAL:

1. Drain the engine transmission oil and remove the clutch cover.
2. Remove the clutch nut (NOT left hand thread) on the end of the crankshaft with the clutch nut removal tool.

CAUTION:

It is possible to cause damage to the piston when using the piston stop. Care must be used when removing and installing the clutch arbor and using the piston stop.

3. Attach the Universal Puller. There are three 6mm clutch puller holes located on the ends of the center hub.
4. Install each of the 3 6mm x 55mm socket head cap screws (clutch cover bolts can be used) until each is similarly snug and the puller looks square to the end of the crank
5. One at a time, tighten each of the 1/4 turn until the clutch 'pops' off



NOTE:

It may be helpful to use a screwdriver or similar device in the side hole of the puller to stop rotation

CAUTION:

Do not use a jaw type puller.

CLUTCH WASHER STACKUPS:

Once the clutch is removed, and cool to touch, carefully put it into a vice and remove the center shoulder bolt out of each clutch shoe. You WILL have to heat the center hub again to remove the bolts. Once you get a bolt loosened, carefully remove it with the shoe and observe the way the spring washers are stacked. Clean the washers and bolt if you intend to reuse.

CAUTION:

You **should apply heat** to the arbor near the clutch bolt threads or you will very likely break the Torx bit upon attempted removal.

The spring stacks in your Cobra clutch will contain 11 individual springs and flat washer(s) configured as a 5 ½ stack. See figure 32. This clutch is designed such that it reconfigured by the customer to achieve different clutch engagements 'hits' by changing washer counts and configurations.

CAUTION:

Generally reassemble the springs as you removed them from the engine or as you received them from Cobra. If you are unsure call the Cobra Technical Support Group 517 437 9100 and consult the experts.

5GX CLUTCH ASSEMBLY REFERENCE DRAWING		
REF #	PART #	DESCRIPTION
1	CAMU0009	Set of three shoes, springs, bolts, flat washers & nuts
2	CAMU0014	Set Of three springs, washers, bolts & nuts
Not Shown	CAMU0002	Complete assembled clutch (Arbor, shoes and washer stacks)

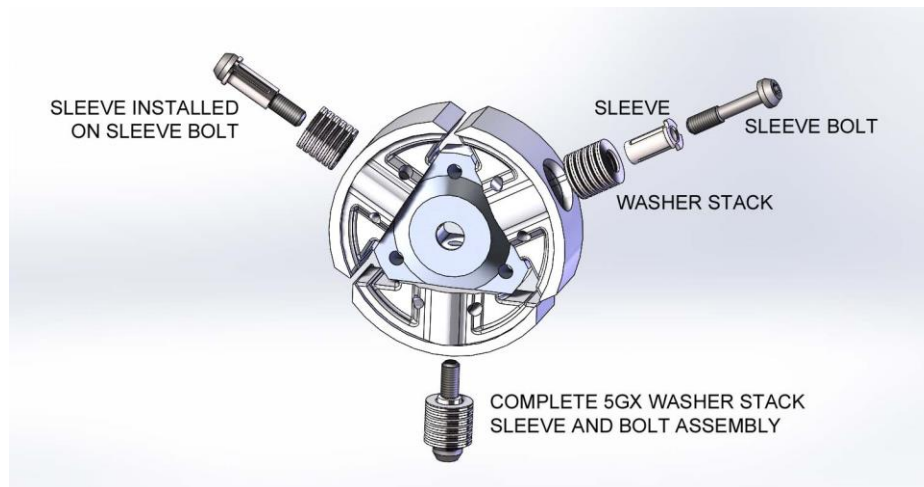

Figure 32 Some configuration of clutch spring stack. Each ‘spring’ stack contains multiple springs (Belleville washers) - arranged into three, four, or five ‘flying saucers’, or turned away against the flat washer(s). Shown is the 5 ½ stack..

Stack	Total Springs	Flying Saucers or Cymbal Pairs	Turned Away or Dish Stacked	Std. Flat Washer(s)	HIT
5 ½	11	5	1	VARIED	HARD
4	11	4	3	VARIED	SOFTER

Clutch adjustment washers

Your Cobra comes stock with flat washer(s) at the bottom of the spring washer stack. Cobra offers several thicknesses of thin adjustment washers that allow clutch engagement tuning. Increasing the flat washer(s) thickness increases the engine speed for clutch engagement thus increasing the abruptness of clutch engagement (harder hit). Conversely, decreasing the flat washer(s) thickness decreases the engine speed for clutch engagement thus decreasing the abruptness of clutch engagement (softer hit).

Part #	Thickness mm (inch)
HKCSM015	1.5 (0.060)
HKCSM012	1.2 (0.047)
HKCSM008	0.8 (0.031)
HKCSM006	0.6 (0.025)
HKCSM005	0.5 (0.020)
HKCSM004	0.4 (0.015)
HKCSM003	0.25 (0.010)
HKCSM001	0.12 (0.005)
HKAM0022	CLUCTH SHIM KIT

NOTE: HKAM022 Clutch shim kit includes - 3 each .005”, .010”, .015” and .020” shims along with 2 clutch to hub spacers and 2 thin clutch to hub spacers.

Use the table above to order adjustment washers. Replace the stock washer with the proper combination of adjustment washers that delivers the desired clutch hit.

CAUTION:

It is easy to prematurely damage the clutch and other engine components with improper clutch adjustment. If you are unsure of how to adjust the clutch, contact the Cobra Technical Support Group before making adjustments.

Clutch shoe wear:

- This can be measured by the overall diameter of the shoes installed on the arbor. This measurement should be greater than 80.5mm
- If the clutch has been slipping and shows signs of glazing, it is best to replace the shoes. We have found that once the shoes are glazed, even if deglazed with emery paper or a file, the performance is reduced.
- The best way to prevent glazing is by not gearing too high, changing the oil as specified and by not blipping the throttle. Every time you blip the throttle, you are working your clutch springs.

Clutch basket wear:

- The internal diameter of a new clutch basket should measure ~84.10mm. Over time the clutch shoes will wear the internal surface down creating a bigger ID and causing a later engagement. The maximum ID we recommend to allow is 84.25mm.

CAUTION:

The clutch produces a tremendous amount of heat and when a rider is blipping the throttle. This makes the clutch and clutch springs wear out quicker. This also makes your engine tend to run hotter which decreases engine power. It is important to train your rider **NOT** to be a **throttle 'blipper'**.

CLUTCH ASSEMBLY:

1. Start with a new set of pre- assembled washer stacks or a cleaned, reassembled set of washer stacks and bolts.

CAUTION:

It is also important that all three shoes are stacked the same. (See figure 32)

2. Clean the threads of the stack bolt and the clutch with brake cleaner removing all old thread locking material.
3. Assemble the stacks and shoes on the arbor using high strength thread lock material to the stack bolt and tighten to 16 Nm (12 ft-lb, 144 in-lb).

CAUTION:

Avoid allowing excess thread lock material to contact the spring washers and the clutch or the clutch is likely to malfunction.

4. Clean the threads of the crank shaft and the clutch nut.

5. Install the clutch arbor on the crank. Making sure that the backing spacer is in place on the crank.
6. Apply high strength thread locking agent to the threads and install the clutch nut and torque to 40 ft-lb (54Nm).

INSPECTION NOTE:

- a. There must be in / out play in installed clutch, 0.3mm to 1.0 mm (0.012" to 0.040").
- b. This should be adjusted with the ECMU0040T and ECMU0040 shims
- c. A blue clutch drum is worn out from excessive slippage or improper lubrication.

7. Install the clutch cover tightening the bolts from inside out. (8 or 10 mm socket, 5.8 ft-lb, 7.8 Nm).

NOTE: To ensure proper engagement of the kick gear with the starter nut, tighten the six screws only to the point of being not extremely loose. Using one hand rotate the kick lever to ½ stroke and hold while tightening the six screws completely with the other hand.

8. Fill with oil (295 ml (10.0 oz) *Cobra 3 Shoe Clutch Milk* (Part # MCMUGF32).

Ignition

Stator care

Stator failure could result from running the bike hot. Following is a list of things that will make your engine run hot.

1. The timing should not exceed the maximum specifications listed.
2. Improper carburetor jetting.
3. Improper spark plug heat range. Never run a hotter plug than the specified spark plug.
4. Clutch slippage. See "CLUTCH" section for causes of slippage.

CAUTION:

- Because of the amount of heat generated by the clutch and engine during extended periods of riding, it is advisable to remove the ignition cover afterward to allow the ignition to cool off. The heat transfers through the cases and can damage the stator as it cools off because of lack of airflow around the stator.
- Ignition will overheat if the gap between the rotor and stator is not large enough. There should be even clearance as the rotor rotates relative to the stator.
- Ignition timing is not adjustable. Changing the ignition timing can degrade performance.
- Make sure connections are free of dirt.

CAUTION:

Advancing the ignition timing will cause the engine to run hotter, in-turn causing power loss, shortened clutch life, and possibly lead to premature stator failure, and can also cause detonation which can lead to premature piston and ring failure.

Tools recommended for timing service:

- Compact motorcycle dial indicator (ECMU0079)
- Universal clutch puller- a universal puller that pulls the clutch, main drive gear and rotor. (Part # MCMUTL70).

CONFIRM YOUR IGNITION TIMING:

1. Remove the spark plug.
2. Insert the dial indicator into the spark plug hole.
3. Remove the four bolts from the ignition cover.
4. Remove the water pump belt from the rotor and water pump shaft.
5. Turn the crankshaft counterclockwise until it reaches top dead center.
6. Set the dial indicator to zero
7. Turn the crankshaft clockwise until the dial indicator reaches 0.035" (0.9 mm) from top dead center.
8. At this position the line on the rotor should align with the center of the stator coil at 5 o'clock position on stator frame. If not loosen the three 5mm bolts to adjust the stator.

ROTOR INSTALLATION:

1. Torque the nut on the rotor to 30 ft-lb (45 Nm) with medium strength (blue) thread locking agent.
2. Recheck the timing following the procedure of *timing your ignition*.
3. Install the water pump belt back on.
4. Bolt the ignition cover back on.
5. Put the spark plug back in, and firmly stick the spark plug cap onto the spark plug.

Cooling System

Radiator fluid removal:

Remove the coolant drain plug (10mm hex key) on the bottom of the engine cases.

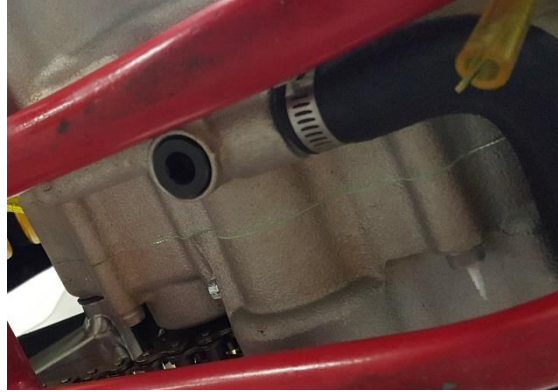

NOTE: Inspect the old coolant for evidence of oil, combustion byproducts (black 'oil slick' stuff) or other things that may indicate a problem.

Tools recommended for impeller service:

- Flat head screwdriver
- 2.5mm hex key
- 3mm hex key
- 4mm hex key
- 10mm hex key
- Water Pump Installation tool - MCMUTL08B
- Slide hammer with
 - fitting to thread into threads on end of shaft (M6x1.0)
 - single and double hook ends for removing plastic impeller
- Hammer

COBRA IMPELLER SERVICE INSTRUCTIONS

1. Remove radiator cap and drain engine coolant as described above.

NOTE: If the impeller is damaged or broken completely back flush the coolant system to ensure no solid pieces are in the system.

2. Remove ignition cover and water pump cover using a 3mm hex key
3. Using a 3mm hex key, remove the screw in the water pump shaft stop hole.

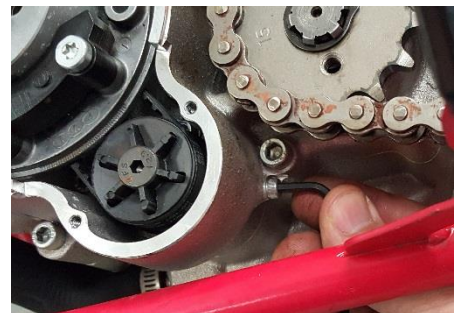

4. Stick a 2.5mm hex key in the water pump shaft cross hole, and remove belt retainer screw using a 4mm hex key. (Figure 41 - item 1)
5. Remove belt retainer, water pump belt and water pump fan pulley.
6. Remove bearing retainer screw using a 3mm hex key.

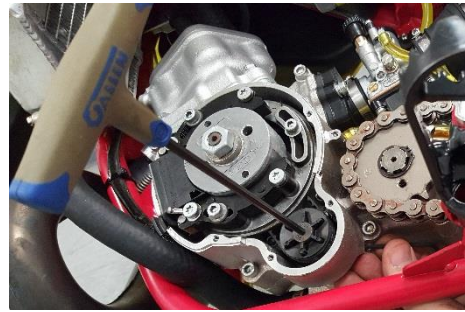

7. Thread a slide hammer onto the end of the water pump shaft and remove the assembly.

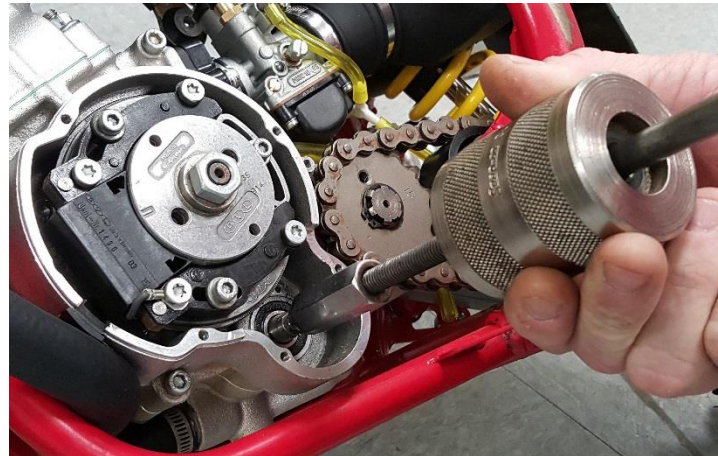

8. Clean any debris or particles from the bore and use some light emery cloth to remove any scratches in the surface that the removal process may have created.
9. Lubricate the bore with grease.
10. Prepare for assembly by installing the water pump assembly into the assembly tool and align the tool with engine case making sure alignment pin is in proper hole.

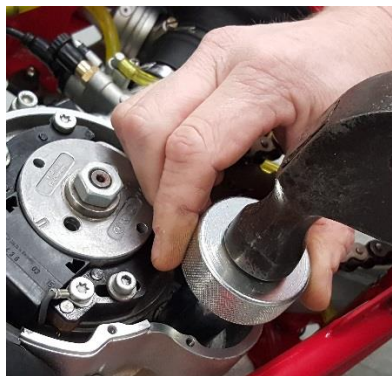

CAUTION:

Damage may occur if one attempts to install the water pump assembly and it's not aligned correctly in the bore.

10. Holding the tool squarely over the water pump assembly tap it firmly into place.
11. The assembly is installed properly when the retaining screw can be tightened and it does not cause a bind on the spinning shaft (use medium strength thread lock on the retainer screw).

NOTE: It may be necessary to tap the outer bearing race in (hammer & blunt punch) or out (with slide hammer) to insure proper free operation of the shaft while the screw is tight.

12. Reinstall the pulley, belt and fan cover using a 2.5mm hex key to stop the rotation of the water pump assembly while tightening with medium strength thread lock to 10 ft-lb (14Nm).

13. Reinstall the covers

NOTE: Refill the coolant system with 50/50 antifreeze-coolant / distilled water.

CAUTION:

Do not mix Propylene Glycol based coolant / antifreeze solutions with Ethylene Glycol based coolant / antifreeze solutions.

Fuel & Air System

Carburetor:

Tools recommended for carburetor service:

- Small flat head screwdriver
- WD-40
- 8mm socket

Your Cobra is equipped with an adjustable carburetor. Some fine-tuning may be needed according to weather condition and altitude. Proper jetting is **very** important for engine performance and engine life. Serious damage to the engine can occur if not properly adjusted.

IDLE ADJUSTMENT:

On the left side of the carburetor, there are two adjustment screws. The larger screw with the knurled head is the idle adjustment screw. To raise the idle, turn the screw in clockwise (in 1/4 turn increments) and rev the engine after each adjustment. To lower the idle, turn the screw counter-clockwise.

TOP END JETTING:

Indications that the engine is running too rich (too much fuel for the air) are:

- Engine not revving out or blubbering at high RPMs.
- Engine will not 'clean out'
- Wet or black spark plug

NOTE: Before changing jetting be sure that the air filter is properly cleaned and has the usual amount of air filter oil. An overly dirty air filter can cause the engine to run rich.

If the engine is running rich on the top end it should be leaned out. Leaning it out can be done by:

1. Changing the main jet to a smaller number.

2. Raising the needle clip (this lowers the jet needle) one notch at a time on the slide.

Indications that the engine is running too lean are:

- Engine cutting out on top end.
- Engine overheating and ultimately seizure.
- White spark plug

CAUTION:

It is much safer to operate the engine slightly rich as opposed to slightly lean. This is because an overly rich engine will just run poorly while an overly lean engine will seize, potentially causing an expensive top end rebuild and a DNF.

To richen the carburetor:

1. Change the main jet one number at a time (larger).
2. Lower the needle clip (raising the jet needle) one notch at a time until the engine starts to blubber on the top end, then move the clip back up one notch or until you get the blubber out.

FUEL MIXTURE SCREW

The smaller brass screw that is towards the front of the engine is a fuel mixture screw. This screw will also richen and lean your engine more on the bottom and mid-range. In warmer conditions, turn the screw in. In colder conditions, turn the screw out. Be sure to keep the carburetor very clean and make sure you don't have water or dirt in the carburetor bowl. Use automotive carburetor cleaner or WD-40 to clean the carburetor inside and out.

Cleaning the carburetor:

⚠ WARNING

Clean the carburetor in a well-ventilated area, and take care that there is no spark or flame anywhere near the working area; this includes any appliance with a pilot light. Because of the danger of highly flammable liquids, do not use gasoline or low flash-point solvent to clean the carburetor.

1. Make sure the fuel is shut off.
2. Remove the carburetor.
3. Drain the fuel from the carburetor.
4. Disassemble the carburetor.
5. Immerse all the metal parts in a carburetor cleaning solution.
6. After the parts are cleaned, dry them with compressed air.
7. Blow out the fuel passages with compressed air.
8. Assemble the carburetor
9. Install the carburetor onto the motorcycle.

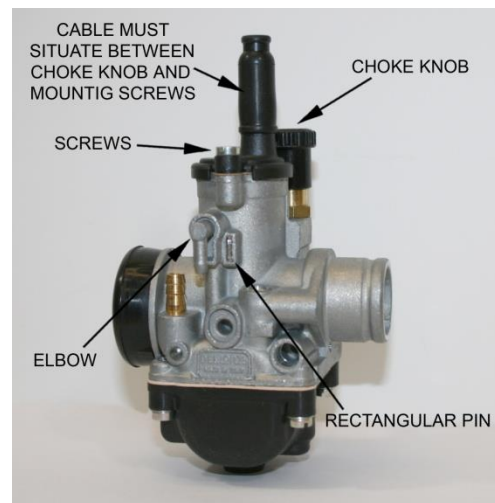

CAUTION:

The motorcycle will only operate properly if the carburetor top is installed properly with the mounting screws, cable and choke knob oriented as shown.

Reeds:

- The reeds must lay flat on the reed cage.
- If the reed tips aren't lying flat, replace them immediately.
- The reeds must have a tight seal on the reed cage.
- If the reed is damaged in any way, replace it. This means cracks, chips, and ruptures. Anything abnormal, replace the reeds.

Take the reed cage out and hold it up to the light and look in through the cage. If you see light, it is not necessarily a bad thing, but the pedals may need to be replaced. Bikes have been known to run real well with light visible past the reed tips as long as the jetting proper for the conditions.

Exhaust

The pipe is a crucial element to a motorcycle. Any kinks, dents, or damage done to the pipe will result in a major performance loss.

NOTE: Be sure to take the pipe off, and any carbon that may be built up. Carbon build up is created from exhaust. Exhaust has oils in it, and the oils cling to the walls of the inside of the pipe. Over a long period of time, the diameter of the pipe will decrease, due to carbon build up. So it is essential to clear the residue.

NOTE: If your bike sounds louder than normal, this is a strong indication that your silencer needs repacked. Wheels & Tires

Rear wheel pullers

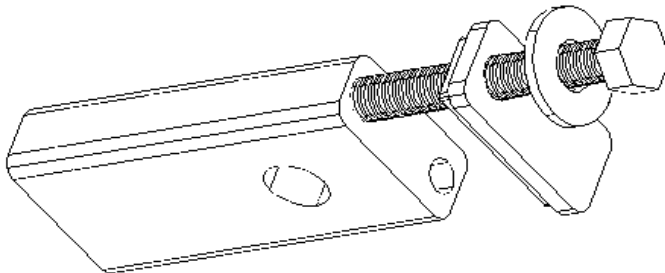

1. Remove axle, and back wheel assembly.
2. Pull the rear wheel pullers out of the back of the swing arm.

Figure 38

Rear wheel alignment:

By eye, ensure that the rear sprocket is running true (in-line, planar) with the front sprocket. When the sprockets are running true, the wheel is properly straightened, and the chain will run straight.

Brakes

Check before each ride:

- Make sure the brake does not have any leaks by holding the lever in while checking hose connections.
- Make sure the brake lever pressure is OK by pulling in on the lever and ensuring full braking performance is achieved before the lever touches the handlebar. If this is not the case, pump the lever several times until the lever feels firm.
- Always make sure the rotor and brake pads are free from oil and grease. Clean the rotor with mild dish soap or alcohol. Contaminated pads must be replaced.
- Ensure that the brake caliper is centered over the brake rotor. If a correction is needed, Cobra has thin brake shims to help make minor adjustments in alignment.
- Always leave adequate free-play in the lever or pedal.

CAUTION:

This brake system uses only DOT 4 or 5.1 brake fluid!

Front Forks

The front forks are fully serviceable but it is recommended that only trained professionals should service them. Contact Cobra for questions and service of your forks.

Rear Shock

The rear shock is fully serviceable but it is recommended that only trained professionals should service your shock. Contact Cobra for questions and service of your CX50 SR shock.

Tuning

Clutch

There are performance characteristics to observe and things to measure.

- 1) Performance characteristics to observe
 - a) Clutch coming in **too late**
 - i) Engine rev's to a high RPM before moving the motorcycle
 - ii) Clutch never fully engages on a reasonable straight stretch
 - iii) Basket turns blue in short amount of time
 - b) Clutch coming in **too early**
 - i) Motorcycle moves too soon when accelerating off idle
 - ii) Motorcycle moves but not with much power
 - iii) Clutch fully engages before the 'power band' kicks in
- 2) Things to measure that can have an effect
 - a) Spring washer configuration
 - b) Spring stack without flat washer
 - c) Thickness of flat washer
 - d) Individual spring washer thickness
 - e) Individual spring washer height
 - f) Effective bolt shoulder length
 - g) Shoe thickness (difficult to measure accurately - can only be approximated by the size of the step where it sticks out of the basket)
 - h) Basket has worn and is too large

There is a relationship between observed characteristics and the things that can be measured

If a clutch comes in **too early**, it means that clutch spring stack is not providing enough force to keep the shoes from being thrown out to the clutch basket at the proper time with the given shoes, basket, arbor, and bolt. This can be due to:

1. Clutch spring stack is too short
 - Wrong configuration
 - Sacked out (over stressed) washers
 - Too thin a flat shim in the stack
2. Spring rate too low (wrong configuration with proper stack height)
3. Clutch arbor shoulder bolt is too long

If a clutch comes in **too late**, it means that clutch spring stack is providing too much force to keep the shoes from being thrown out to the clutch basket at the proper time with the given shoes, basket, arbor, and bolt. This can be due to:

1. Clutch spring stack too tall
 - Wrong configuration

- Too thick a flat shim in the stack
- 2. Spring rate too high (wrong configuration with proper stack height)
- 3. Clutch arbor shoulder bolt is too short
- 4. Clutch shoe material has worn too thin
- 5. Clutch basket has worn too much and is too large of a diameter

With the exceptions of component failures, generally two things will occur:

- 1) The clutch shoes will wear causing the clutch to engage later, and
- 2) The springs will sack causing the clutch to engage earlier.

Typically the springs will sack at a quicker rate than the shoes will wear, meaning that an un-tampered clutch that worked fine will ultimately hit too early at some time. When this occurs it is easily remedied with a new spring stack **or** a thicker flat shim. Because the shoes have worn, a thinner flat washer may be needed with the fresh new springs to allow proper clutch engagement.

One thing to remember:

If your clutch is hitting fine, don't mess with it!

Some things to remember to aid clutch life

- Change oil each ride
- Gear to the low side
- Avoid mud if possible
- (Cut mud practice to 1 lap or none)
- Stay on the gas (no throttle blipping)
- Run more air pressure to allow wheels to spin (helps throttle steer)
- Make sure wheels spin freely (no bent rotors, dragging brakes, chain too tight, etc...)
- Make sure the engines pulls cleanly and strong by having properly maintained engine with correct ignition timing and carburetion.

With the exceptions of component failures, generally two things will occur:

- The clutch shoes will wear causing the clutch to engage later, and
- The springs will sack causing the clutch to engage earlier.

Typically the springs will sack at a quicker rate than the shoes will wear, meaning that an un-tampered clutch that worked fine will ultimately hit too early at some time. When this occurs it is easily remedied with a new spring stack **or** a thicker flat shim. Because the shoes have worn, a thinner flat washer may be needed with the fresh new springs to allow proper clutch engagement.

Effective length of the shoulder on the clutch arbor bolt (see Figure C1). Nominal is 16.00mm (0.630"). As this decreases, the spring stack needs to decrease equally. This can change due to the shoulder bolt 'setting' into the arbor (see C2)



Figure C1

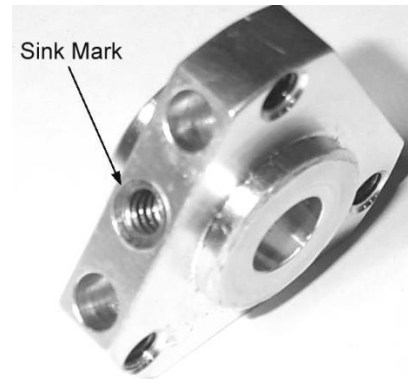

Figure C2

If your effective shoulder length is off, or your shoes are worn, adjust the height of your overall combined spring stack accordingly (i.e. if your effective shoulder length is 0.5mm short of the 16.00 measurement, decrease the overall combined spring stack height by 0.5mm, or if your shoes are worn by 0.5 mm, increase the overall combined spring stack height by 0.5mm).

Frequently asked questions

Q: When should the springs be replaced?

A: When the clutch 'hit' occurs too early or too late.

Q: Should the clutch springs be replaced if the shoes wiggle on the arbor?

A: Not if the clutch is 'hitting' correctly. Don't mess with it

Q: What is the acceptable tolerance on any of the measurements?

A: For the most part that does not matter. Suffice it to say that any efforts to make the three shoes behave identically will make the best performing clutch. Taking extra time to balance the three stacks (shims, springs, bolts, etc...) to as close to the same length as you are willing to put effort into will result in a better performing motorcycle.

Q: One of my two riders weighs 85 pounds and the other weighs 45 pounds. Should I have their clutches adjusted differently because of their weight?

A: No, there is one best setting and it works for light or heavy riders.

Q: If my clutch basket changes color, should I replace it?

A: If it is blue or purple, replace it. If it is silver or brown, you are fine.

Cobra is now going to greater lengths to ensure that the clutch on your motorcycle is performing the best possible from the shop and so it may have a different clutch stack or shim washer from what you are used to. Please take measurements for knowledge sake but don't blindly restack washers to different heights without first consulting the factory.

Gearing

For a bike with a centrifugal clutch, it's better to be geared too low than too high.

What happens with improper gearing?

- Poor performance
- Not enough top end speed
- No snap
- Over heat clutch
- Premature failure of engine seals, bearings, & electronics
- High clutch wear

Condition	Gear Taller	Gear Lower
Mud		↓ ↓
Sand		↓
Hills		↓
Hard Pack	↑	
Throttle Blipper (novice)*		↓*

*It may be helpful to set up the clutch to hit early for smooth power delivery

Front Sprocket			Rear	Ratio
		16	31	1.94
		16	32	2.00
		16	33	2.06
	15		31	2.07
		16	34	2.13
	15		32	2.13
		16	35	2.19
	15		33	2.20
14			31	2.21
		16	36	2.25
	15		34	2.27
14			32	2.29
		16	37	2.31
	15		35	2.33
14			33	2.36
		16	38	2.38
	15		36	2.40
14			34	2.43
		16	39	2.44
	15		37	2.47
14			35	2.50
		16	40	2.50
	15		38	2.53
14			36	2.57
	15		39	2.60
14			37	2.64
	15		40	2.67
13			35	2.69
	14		38	2.71
13			36	2.77
	14		39	2.79
13			37	2.85
	14		40	2.86
13			38	2.92
13			39	3.00
13			40	3.08

Suspension

Adjustment

1. Front forks
 - 1.1. Fork oil
 - 1.1.1. Oil type
 - 1.1.1.1. Heavier weight oil – more damping – slower responding
 - 1.1.1.2. Lighter weight oil – less damping – quicker responding
 - 1.1.2. Oil quantity / level
 - 1.1.2.1. Greater quantity / higher level – greater bottoming resistance, stiffer near the end of the travel.
 - 1.1.2.2. Smaller quantity / lower level – less bottoming resistance, less stiff near the end of the travel.
 - 1.2. Fork spring
 - 1.2.1. Stiffer spring (higher spring rate) – stiffer throughout the travel.
 - 1.2.2. Less stiff spring (lower spring rate) – less stiff throughout the travel.
 - 1.3. Gas pressure – always bleed off any pressure.
 - 1.4. Fork height
 - 1.4.1. Rise in clamps for quicker turning.
 - 1.4.2. Lower in clamps for improved straight line stability.
 - 1.5. Compression damping
 - 1.5.1. Harder (more damping, slower) – adds resistance to the suspension motion when the suspension is compressing.
 - 1.5.2. Softer (less damping, quicker) – reduces resistance to the suspension motion when the suspension is compressing
 - 1.6. Rebound damping
 - 1.6.1. Harder (more damping, slower) – adds resistance to the suspension motion when the suspension is returning to full length.
 - 1.6.2. Softer (less damping, quicker) - reduces resistance to the suspension motion when the suspension is returning to full length
2. **Rear shock**
 - 2.1. Preload adjustment
 - 2.1.1. More preload (greater distance) – less race sag.
 - 2.1.2. Less preload (smaller distance) – more race sag.
 - 2.2. Shock spring
 - 2.2.1. Stiffer spring – stiffer throughout the travel.
 - 2.2.2. Less stiff spring – less stiff throughout the travel.
 - 2.3. Compression damping
 - 2.3.1. Harder (more damping, slower) – adds resistance to the suspension motion when the suspension is compressing.
 - 2.3.2. Softer (less damping, quicker) – reduces resistance to the suspension motion when the suspension is compressing.
 - 2.4. Rebound damping
 - 2.4.1. Harder (more damping, slower) – adds resistance to the suspension motion when the suspension is returning to full length.
 - 2.4.2. Softer (less damping, quicker) - reduces resistance to the suspension motion when the suspension is returning to full length

Front Fork Operation

The front suspension on the CX50SR works under the principals of hydraulic damping, and it features full adjustability to help tune the fork to meet each rider's needs. The CARD fork contains MXT 'Smart Leg' technology that provides very progressive operation; allowing a small bike to perform well on track surfaces ripped up by larger machines.

The key to Smart Leg technology is to understand that each leg has a different role. The brake side leg features a conventional open cartridge. This cartridge handles both standard compression and rebound damping duties. Rebound damping is adjustable on the fork cap, and compression damping is adjusted at the bottom of the fork. The other leg (the Smart Leg) has no rebound damping, and it contains both a speed sensitive compression damping mechanism as well as a position sensitive one. This design allows for a firm low speed response, controlling rapid chassis pitch, which promotes stability and control. The fork produces significantly less mid and high-speed compression until it travels into the progressive / speed sensitive portion of the smart leg. The speed sensitive compression component is adjustable at the top of the fork.

The combination of the Smart Leg and the conventional leg allows the fork to be very supple throughout all low amplitude operation and yet take punishing hits; producing a progressively increasing damping rate that slows the forks movement as it approaches full bottom. Therefore, the Smart Leg also acts as a hydraulic bottoming control device. Finally, the large degree of adjustability in both legs allows the fork to be tuned to meet each rider's size, ability, and type of riding they do (motocross, off-road, flat track, etc).

Fork Damping Adjustments

Tools required

- Small flat blade screwdriver



and likewise, turning the screw clockwise returns the leg to its position faster. As shown in the (slower) and 'F' (faster) are cap as an adjustment guide.

The speed at which the fork rebounds can be adjusted at the leg.

screw slows which

being



top of the conventional Turning the adjustment clockwise the rate at the fork extends after compressed, counter-extended figure, 'S' etched into the



BOTTOMING ADJUSTMENT

At the base of the conventional leg is another adjustment screw that controls the amount of compression damping. Turning this screw clockwise increases damping and turning it counter-clockwise will decrease it. This is illustrated by the “HARD” and “SOFT” in the figure at the right.

The Smart Leg cap is labeled “Speed Sensitive Bottoming Control”, and this adjuster provides a range of control over how progressive the fork feels. Turning the screw clockwise increases the fork’s resistance to bottoming, while turning the screw

counter-clockwise decreases it. On the track, this effect will be felt on sections where the fork is forced to move very quickly such as on harsh landings or when traversing sharp edged bumps.

Rear Shock Adjustments

Always start with standard settings and make damping changes in no more than two click increments and only make one change at a time.

Symptom	Action
Rear end feels stiff on small bumps	Softer Low Speed Compression Damping
Rear end ‘sways’ on straights	Harder Low Speed Compression Damping
Bike tends to jump ‘rear end high’	Harder High Speed Compression
Bike tends to jump ‘rear end low’	Softer High Speed Compression
Frequent rear end bottoming	Harder Compression Damping
Bottoms after end of continuous bumps	Softer rebound damping
Rear end ‘kicks’ over square edge bumps	1) Harder rebound, 2) Softer Low and High Speed Compression
Rear end feels stiff under acceleration bumps.	Softer Rebound and/or Stiffer Low Speed Compression Damping

Proactive Suspension Adjustments

Once you have the suspension adjusted for decent overall feel, you can make proactive adjustments when faced with different racing conditions.

Situation	Actions
Sand track	Lower the rear end (increase race sag).
Sand track	Stiffer compression and rebound damping.
Long fast track	Lower the forks in the clamps by 3 mm.
Tight slow track	Raise the forks in the clamps by 3 mm.
Mud track	Lower the bike if the rider has difficulties touching the ground.

Shock preload

Loosen the set screw and turn the spring perch in full turn increments to get the desired sag settings.

NOTE:

Always leave the spring perch rotated in such position so that the set screw is easily accessible.

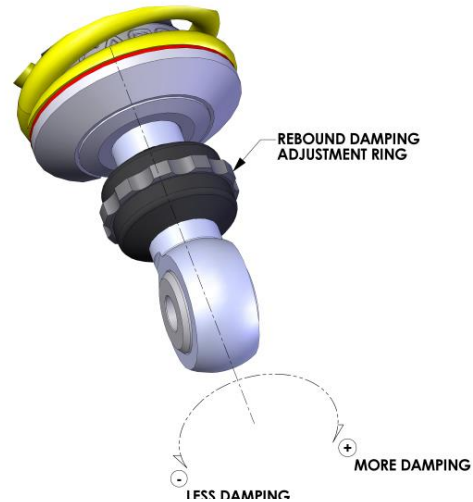

Shock Damping

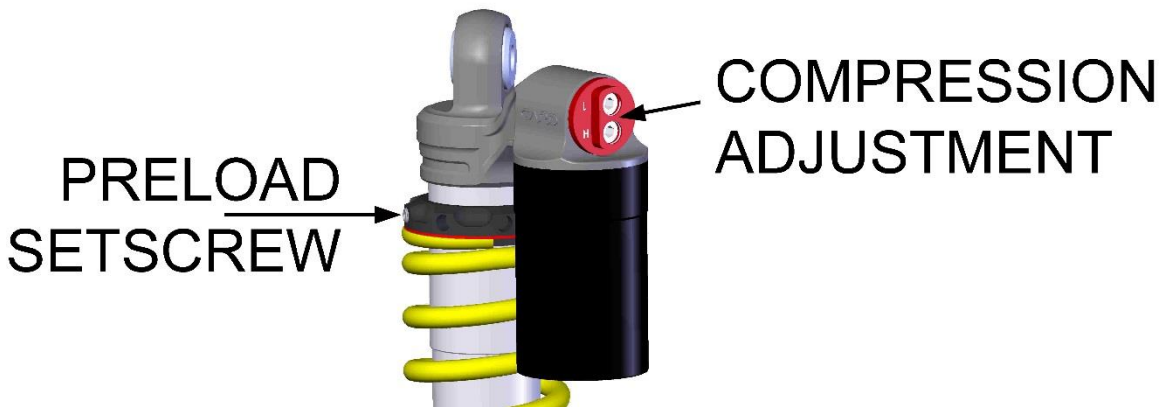

The Low Speed “L” adjustment is what controls how quickly the rear of the bike settles in the corners or how it settles in sweeping ‘flat track’ style corners whereas the High Speed “H” adjustment controls how the shock reacts to kickers. In “+” adds damping or slows it down, whereas out, “-“ speeds up the shock or removes damping.

Carburetion

Although your Cobra is sent from the factory with the carburetor jetted for optimal performance, you may find it necessary to adjustment your particular jetting due to current weather conditions, altitude, fuel variations, and/or engine modifications.

CAUTION:

Proper jetting is very important for engine performance and engine life. Symptoms of improper jetting are listed below.

- Symptoms of incorrect oil or oil / fuel ratio
 - Poor acceleration
 - Misfire at low engine speeds
 - Excessive smoke
 - Spark plug fouling

- Excessive black oil dripping from exhaust system
- Symptoms of too rich a fuel mixture
 - Poor acceleration
 - Engine will not 'rev' out, blubbers on top
 - Misfire at low engine speeds
 - Excessive smoke
 - Spark plug fouling
 - Wet, black, or overly dark spark plug (when removed for inspection)
- Symptoms of too lean a fuel mixture
 - Pinging or rattling
 - Erratic acceleration
 - Same actions as running out of fuel
 - High engine temperature
 - White spark plug (when removed for inspection)

NOTE: When inspecting the spark plug to evaluate jetting, a properly jetted machine will produce a spark plug that is dry and light tan in color.

Environmental and altitude related mixture adjustments		
Condition	Mixture will be	Required adjustment
Cold air	Leaner	Richer
Warm air	Richer	Leaner
Dry air	Leaner	Richer
Very humid air	Richer	Leaner
Low altitude	Standard	None
High altitude	Richer	Leaner
Low barometric pressure	Richer	Leaner
High barometric pressure	Leaner	Richer

NOTE: Before making any carburetor jetting changes verify that:

- You are using the proper fuel and oil
- The fuel is fresh and uncontaminated
- The oil and fuel have been mixed in the proper ratio
- The carburetor is clean (no plugged jets)
- The air filter is properly clean and oiled
- The float height is within proper specification (proper measuring technique is described later in this section)

NOTE: Perform all jetting changes on a motorcycle that has been warmed up to proper operating temperature.

The carburetor on your Cobra motorcycle is quite adjustable. Figure 49 shows its range of adjustment and in particular what adjustable component affects what range of operation (specifically throttle position).

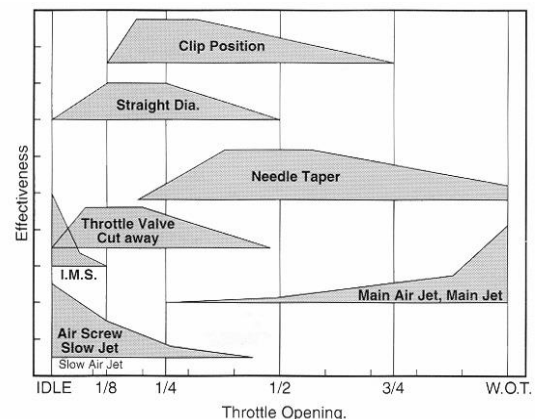

Figure 49

FUEL SCREW ADJUSTMENT: **Adjust for maximum idle speed**

The fuel adjustment screw is located on the left side of the carburetor. It is the smaller of the two adjustment screws and requires the use of a small flat blade screw driver for adjustment. After adjusting for maximum idle speed, use the idle screw to adjust the desired idle speed.

NOTE:

If the fuel screw requires more than 3 turns out, replace the pilot jet for one that is one size richer (larger number) then readjust the fuel screw.

IDLE ADJUSTMENT: **Adjust for desired idle speed**

The idle speed screw is located on the left side of the carburetor. It is the larger of the two screws on the side of the carburetor and is unique with its knurled head for easy fingertip adjustment. To raise the idle, turn the screw in, clockwise, (in 1/4 turn increments) and rev the engine after each adjustment. To lower the idle, turn the screw counter-clockwise.

TOP END JETTING: **Adjust for clean full throttle acceleration**

Jet your top end (main jet) based on the acceleration of your Cobra Motorcycle on the longest straight at the track. Observe any of the lean or rich symptoms (spark plug appearance and bike performance) listed above and change your jetting accordingly.

PART THROTTLE **Adjust for desired acceleration**

Using an area of the track that allows the rider to operate and mid throttle and transition (accelerate, or 'roll on') from closed, or mostly closed throttle, to a larger throttle opening. Observe the rich and lean symptoms listed above. Adjust the jet needle position by moving the clip from its current position (move the clip higher on the needle to make the bike run leaner, or move the clip lower on the needle to make the bike run richer) to one higher or lower.

Troubleshooting

1) Engine operates erratically

- a) Carburetor top is installed backwards
- b) The carburetor slide indexing pin is missing
- c) A carburetor vent elbow is plugged or has fallen out
- d) Faulty stator
- e) An air leak
 - i) Base gasket
 - ii) Intake / reed gaskets
 - iii) Crank seals
 - iv) Crank case gasket

2) Engine is down on power

- a) Clutch engagement is not set properly
- b) Jetting is incorrect
- c) Silencer needs repacked
- d) Exhaust pipe
 - i) Has excess carbon buildup
 - ii) Has large dent in it
- e) Compression is low
 - i) Piston
 - ii) Rings
- f) Reeds are damaged
- g) Ignition timing is incorrect
- h) Stator needs replaced

3) Engine is excessively loud

- a) Silencer needs repacking

4) Engine 'blubbers' at high RPMs

- a) Jetting too rich
- b) Stator needs replaced

5) Engine won't start

- a) Fuel
 - i) None in tank

- ii) Is sour or bad
 - b) Carburetor is dirty
 - c) Ignition
 - i) Spark plug fouled
 - ii) Spark plug cap off
 - iii) Engine Shut-off 'kill' switch is shorted
 - iv) Bad electrical ground
 - v) Stator winding damaged
 - d) Exhaust is plugged with object or flooded fuel
 - e) Engine is flooded
 - f) Cracked, broken, or jammed reed pedal
 - g) Excessive piston or cylinder wear
 - h) Clutch bolt or shoe dragging on basket (drum).
- 6) Engine won't idle**
- a) Idle knob needs adjusted
 - b) Carburetor jets are dirty

Index

Bars and Controls	20	Frame Parts	38
Base Gasket Selection	49	Frictional Drive	17
Break-In	6	Front Brake	
		Parts	40
Carburetor		Front Wheel Parts	41
Parts	21	Fuel System	
Service	64	Parts list.....	64
Specifications	4	Service	64
CFD Cobra Frictional Drive	17	Hardware	
Chain		Frame	38
Adjustment	11	Ignition	
Chassis		Parts	28
Specification.....	4	Service.....	60
Clutch		Timing	61
Parts	26	Jetting	
Clutch Lubricant		How To	64
Replacing.....	10	Stock.....	4
Compression test	49	Troubleshooting.....	76
Cooling System.....	62	Lubrication	
Cylinder head		Recommended.....	4
torque	5	Maintenance	
		Schedule.....	8
		Tips.....	8
Electrical		Oil	
Parts	23	Recommended.....	4
Engine		Parts	
Specifications	4	Bars and Controls.....	20
Exhaust.....	66	Bottom End & Transmission	25
Parts	30		
Fork			
Adjustments.....	74		
Operation.....	74		
Fork oil replacement	16		
Forks			
Service.....	67		

Carburetor.....	21	Adjustments.....	75
Clutch & Kick Starter.....	26	Parts.....	45, 46
Coolant System.....	19, 22	Slip Clutch.....	17
Electrical.....	23	Spark Plug	
Engine.....	25	Recommended.....	4
Exhaust.....	30	Specifications.....	4
Frame.....	38	Starting.....	7
Front Brake.....	40	Stator	
Front Wheel.....	41	torque.....	5
Ignition & Water Pump.....	28	Suspension	
Rear Brake.....	43	Adjustment.....	73
Rear Wheel.....	44	Swingarm	
Shock.....	45, 46	Parts.....	47
Swingarm.....	47	Top End	
Top End.....	29	Parts.....	29
Pullers.....	66	Service.....	48
Rear Brake		Torque Values.....	5
Adjustment.....	12	Transmission Lubricant	
Parts.....	43	Replacing.....	10
Rear Wheel		Troubleshooting.....	79
Parts.....	44	Jetting.....	76
Pullers.....	66	VIN reading.....	8
Reeds.....	66	WARNING	1
Shock		Water Pump	
		Parts.....	28
		Wheels	
		Service.....	66