

QUILL TYP 30

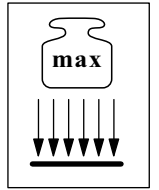

30

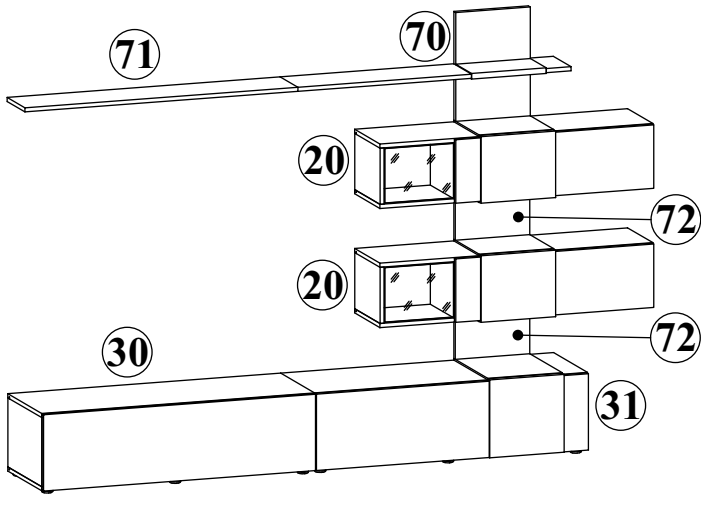

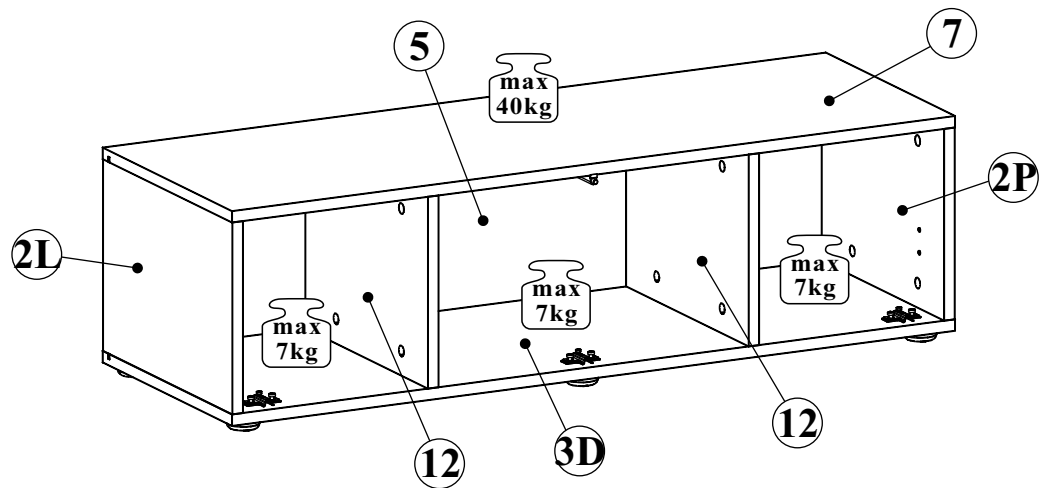
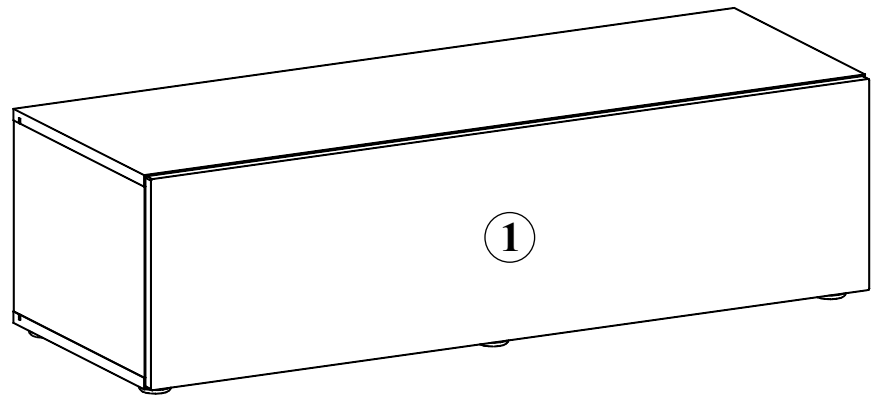

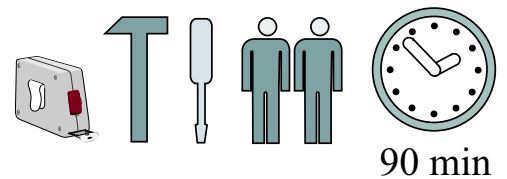





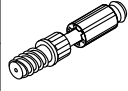

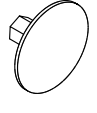

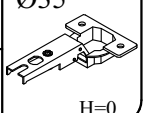
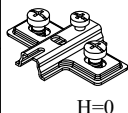
NO	Dim.		Col.-No	Qty
1	296	1096	16	1
2L	268	380	16	1
2P	268	380	16	1
12	268	360	16	1
3D	1100	380	16	1
5	280	1079	3	1
7	1100	380	16	1

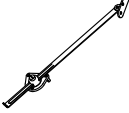

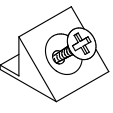
90 min

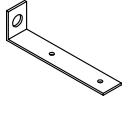
QUILL TYP 30

A1 x16  ø8x36	B4 x16 	B5 x16  Ø15x12	G5 x16 	I11 x6  Ø45, h=15	UP11 x6  UPØ4x20
E21 x3  Ø35 H=0	E2 x3  H=0	D10 x14  USØ3,5x13	G21 x2 	D7 x6  USØ3x16	OD2 x1 
S1 x10 	UP13 x2  UPØ3x16	KR1 x1 	L1 x1 	G2 x1 	

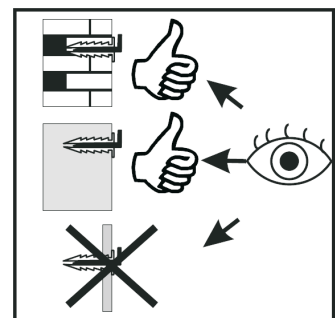
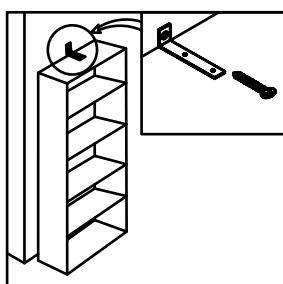
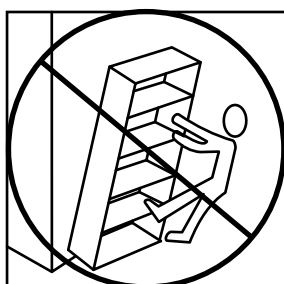
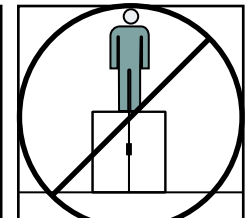
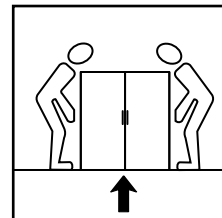
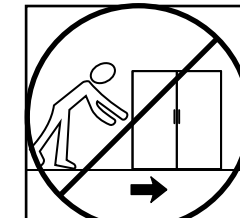
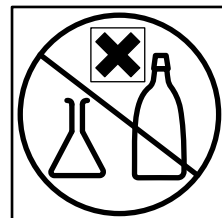
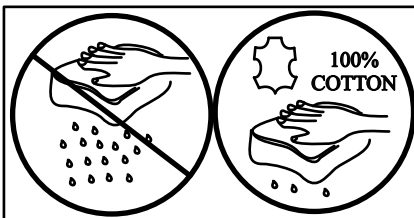
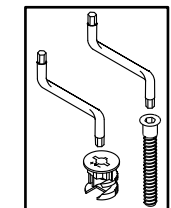
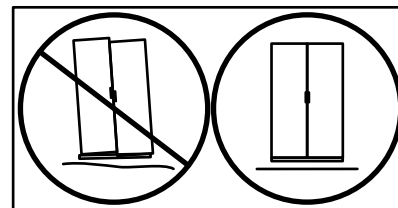
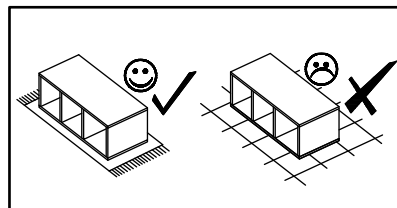
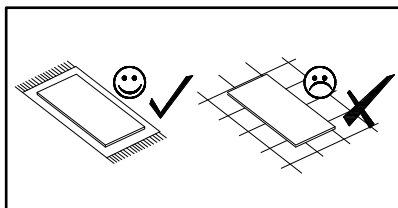
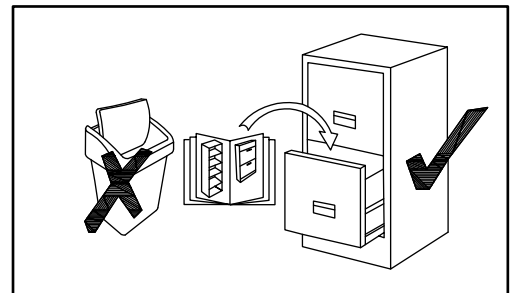
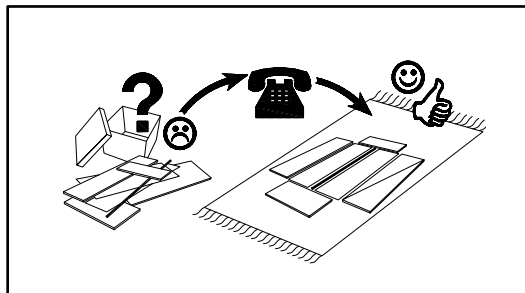
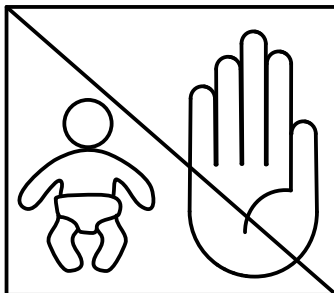
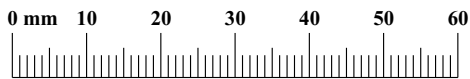

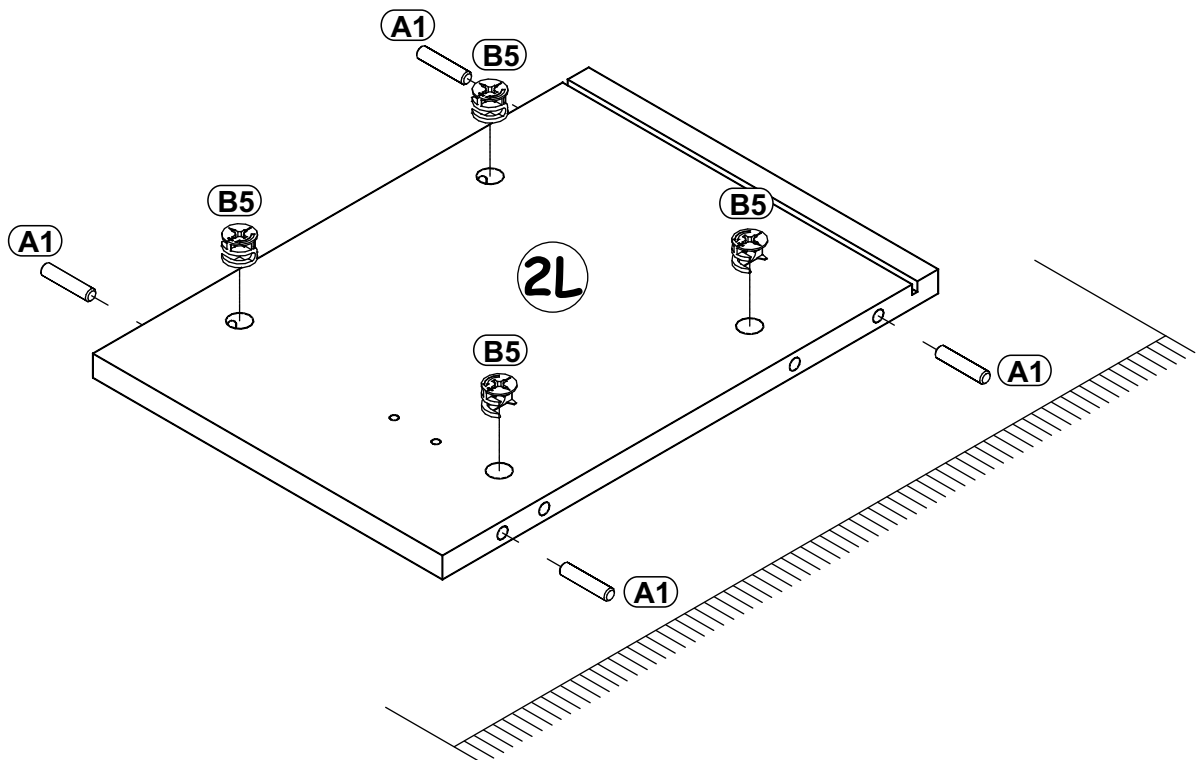
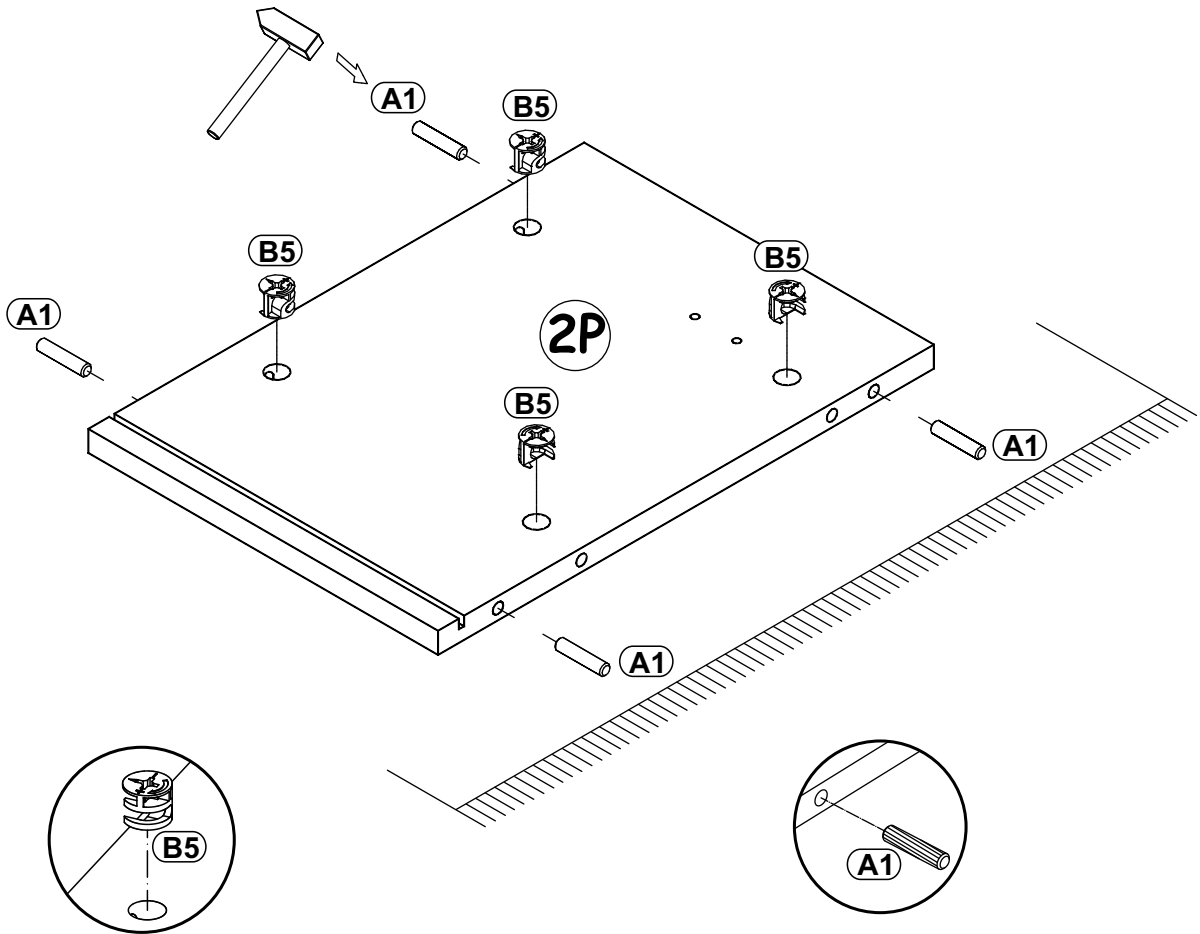
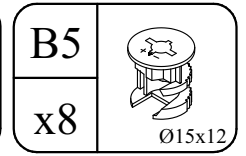
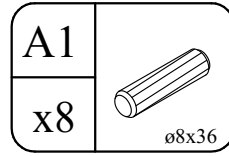

QUILL TYP 30

1

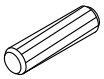

QUILL TYP 30

2

A1		B5	
x8	ø8x36	x8	Ø15x12

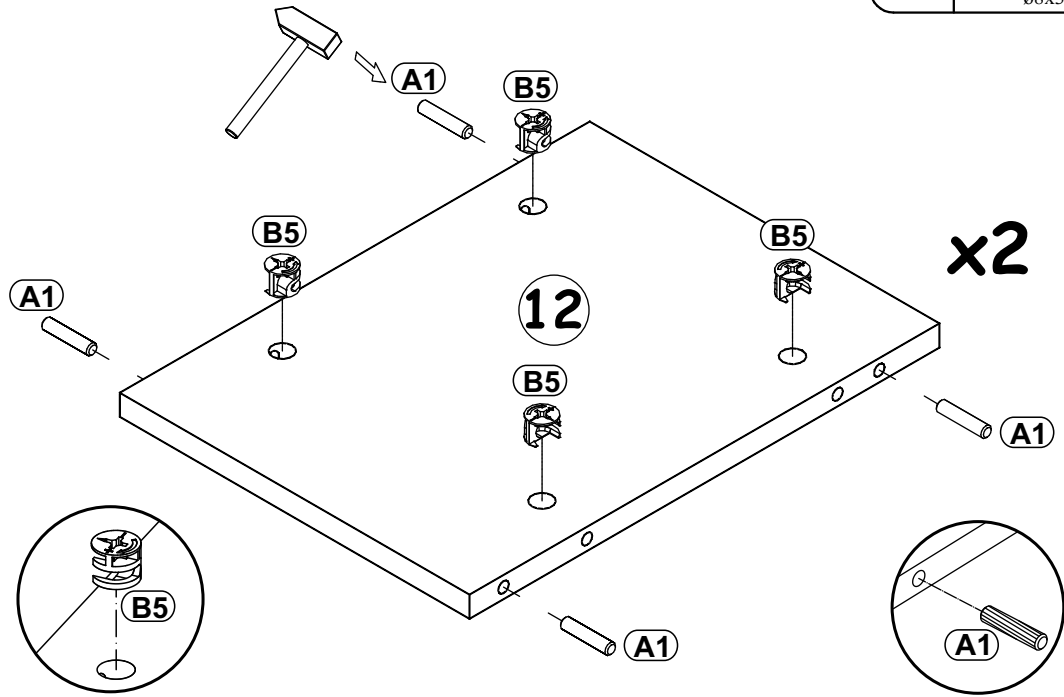

3

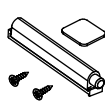
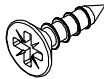
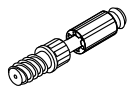
OD2		D10		B4	
x1		x2	USØ3,5x13	x8	

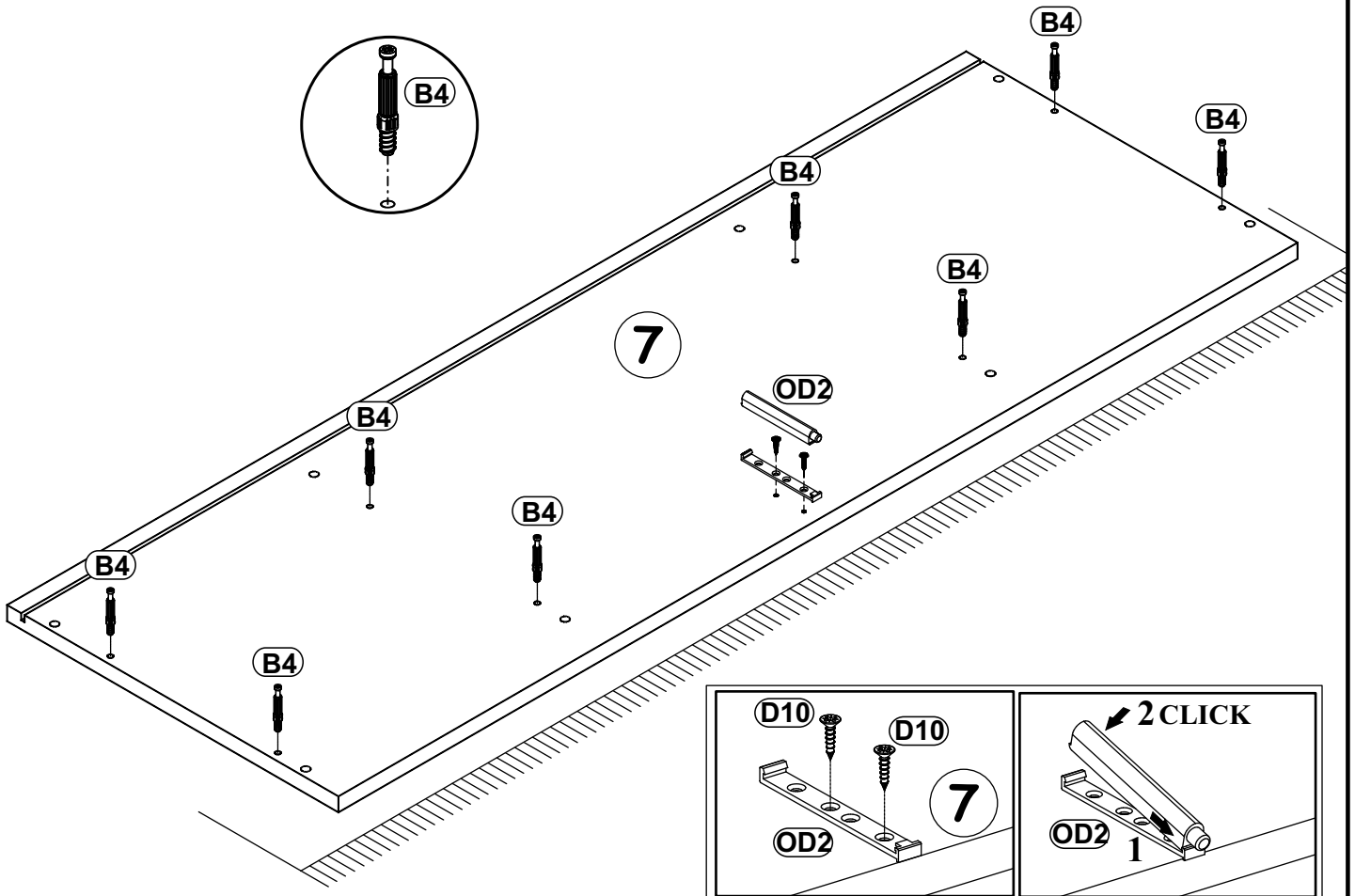

QUILL TYP 30

5

E21	Ø35	D10	 USØ3,5x13
x3	H=0	x6	

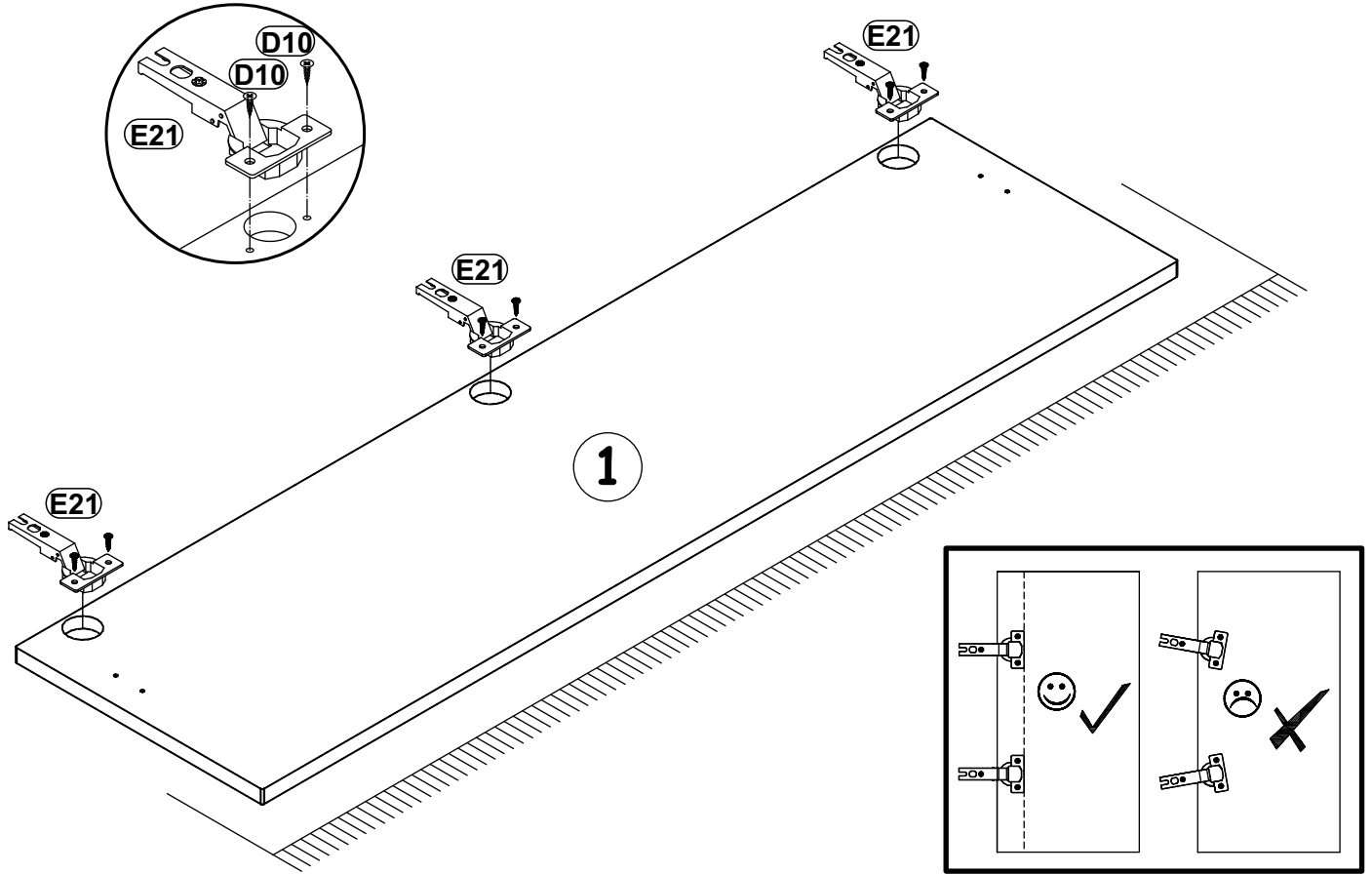

6

G5	
x8	

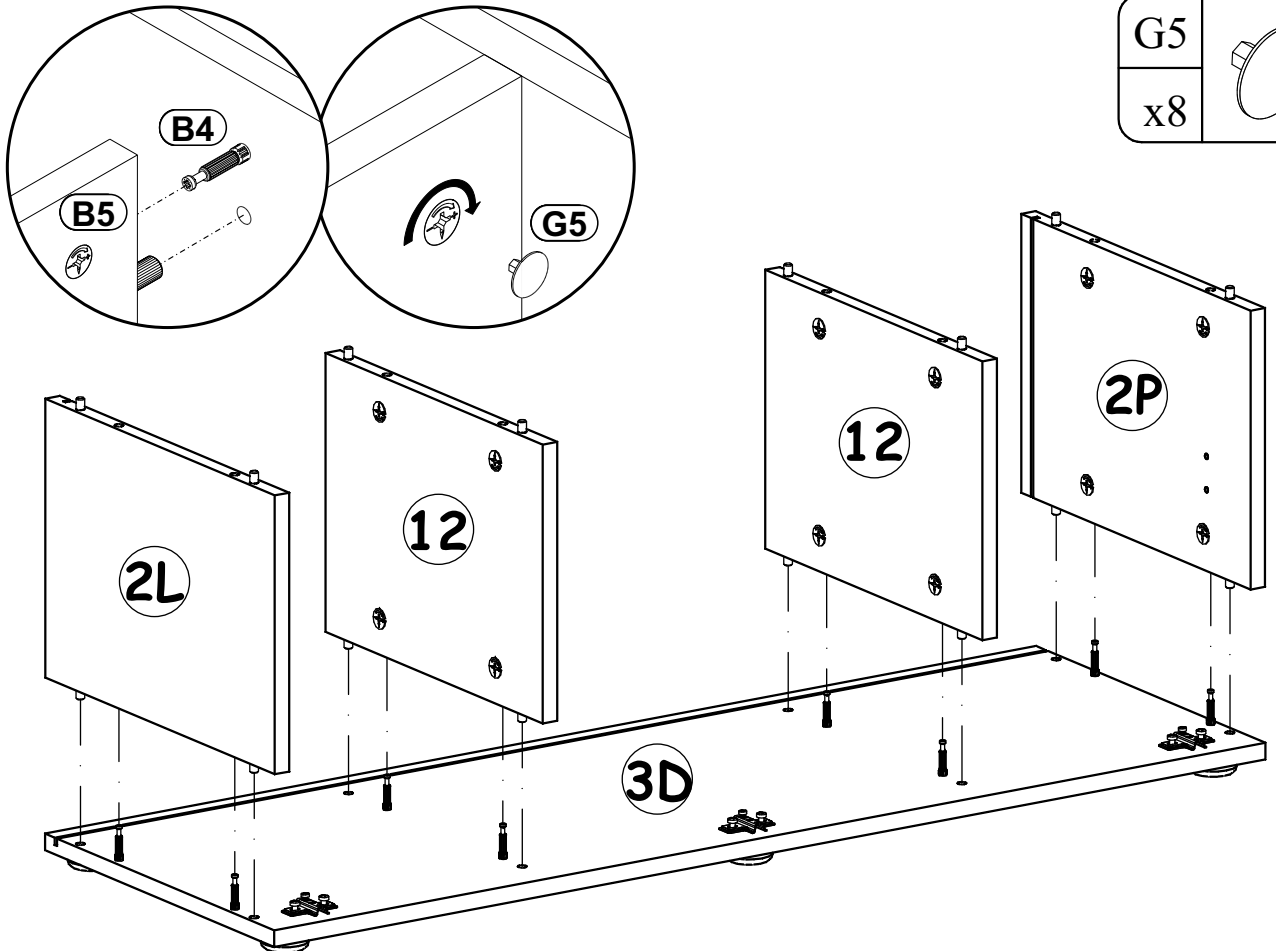

QUILL TYP 30

7

G5

x8

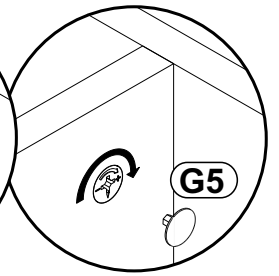
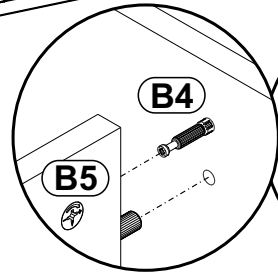
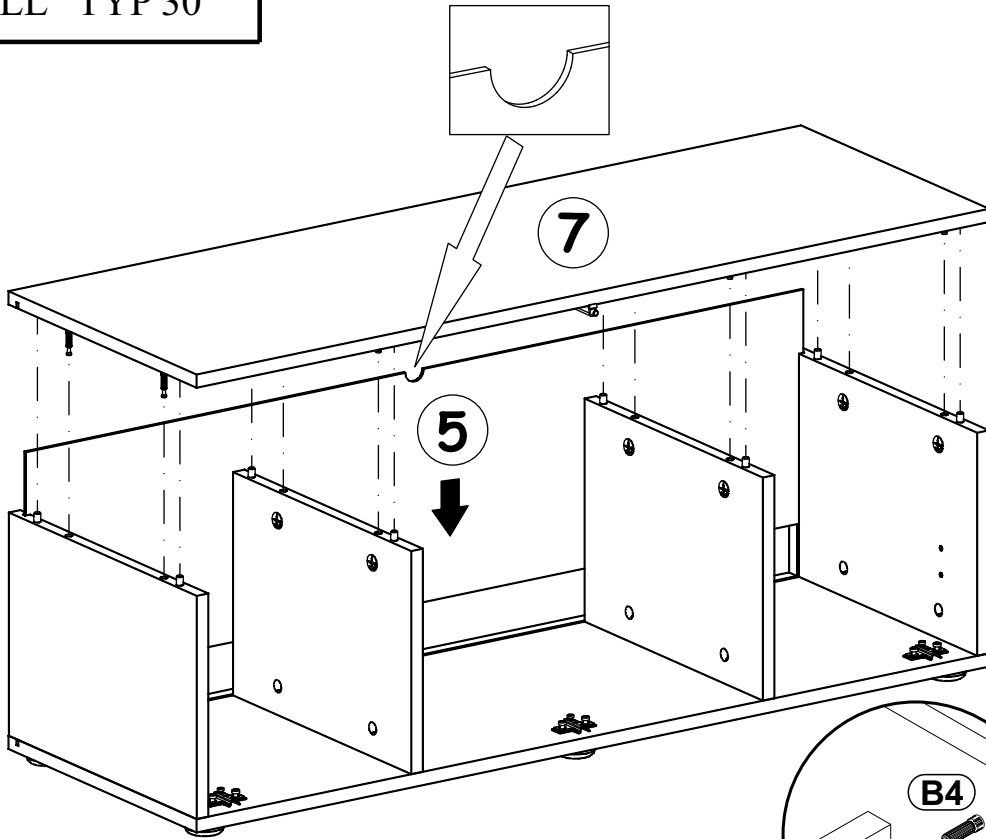

8

S1

x10

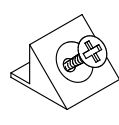

UP13

x2

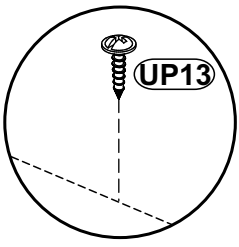
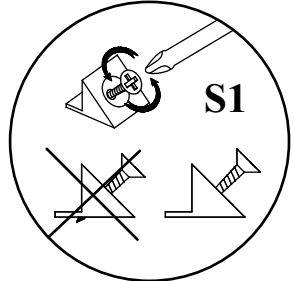

X=Y 90°

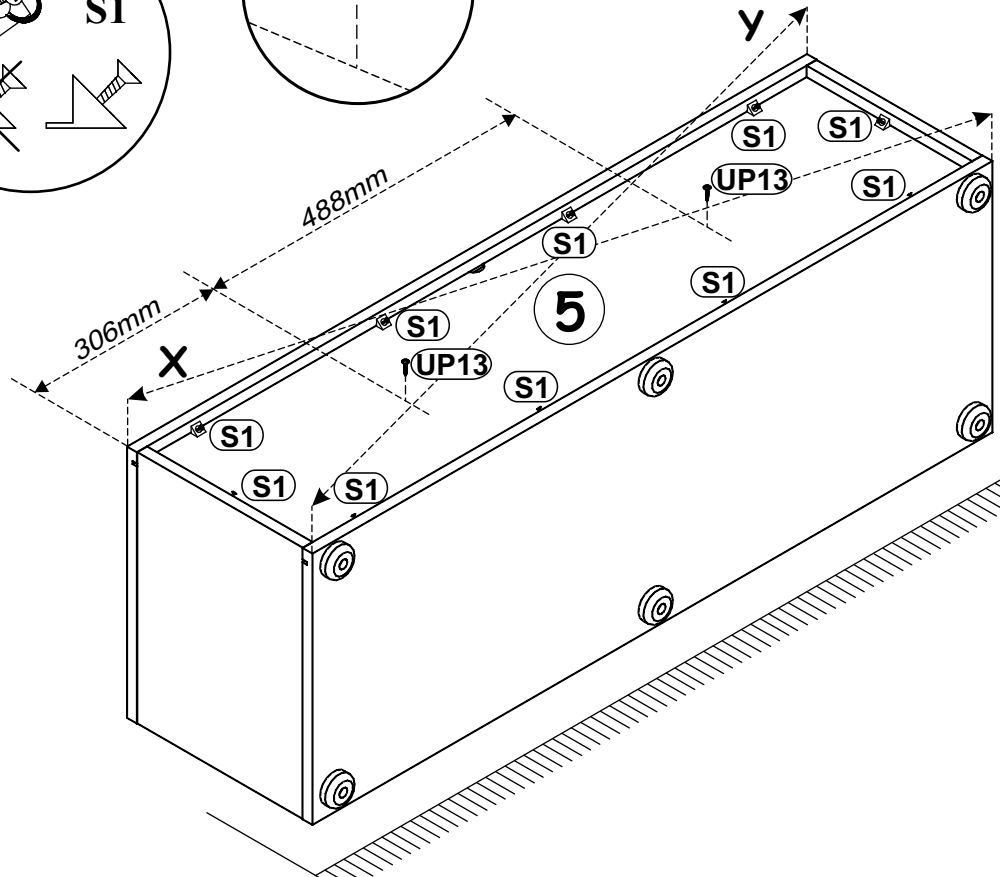
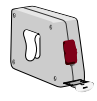

QUILL TYP 30

9

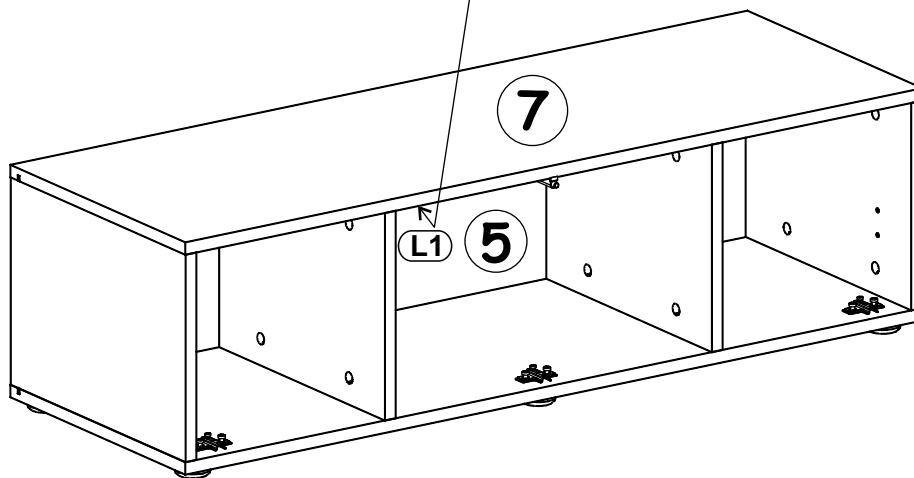
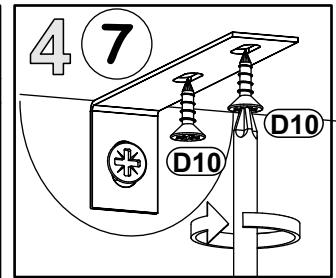
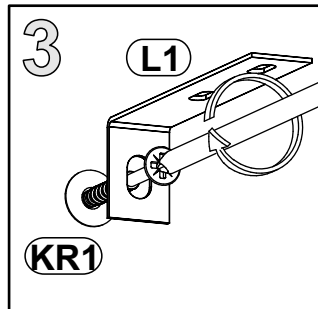
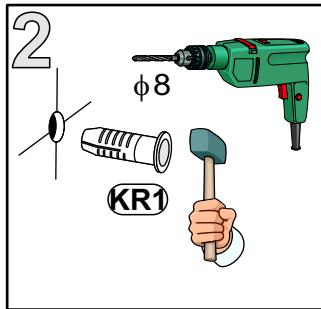
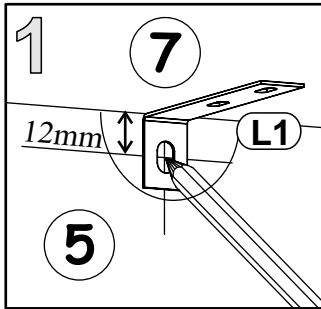
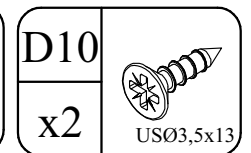
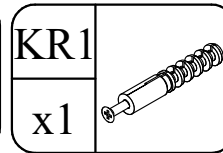
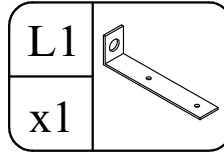
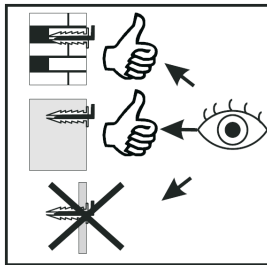

10

