

ABW LYRA TYP 21L

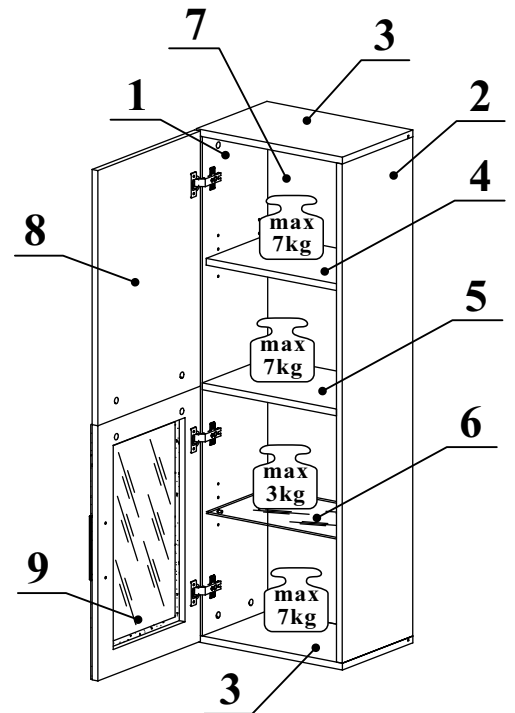

| NO | Dim. | | Col.-No | Qty |
|----|------|-----|---------|-----|
| 1 | 1174 | 275 | 1 | 1 |
| 2 | 1174 | 275 | 1 | 1 |
| 3 | 405 | 275 | 1 | 2 |
| 5 | 372 | 255 | 1 | 1 |
| 4 | 372 | 240 | 1 | 1 |
| 7 | 1186 | 385 | 1 | 1 |
| 6 | 371 | 240 | 1 | 1 |
| 8 | 400 | 600 | 1 | 1 |
| 9 | 400 | 600 | 1 | 1 |

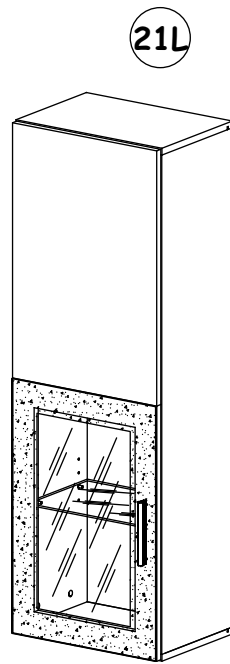
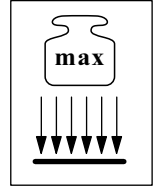
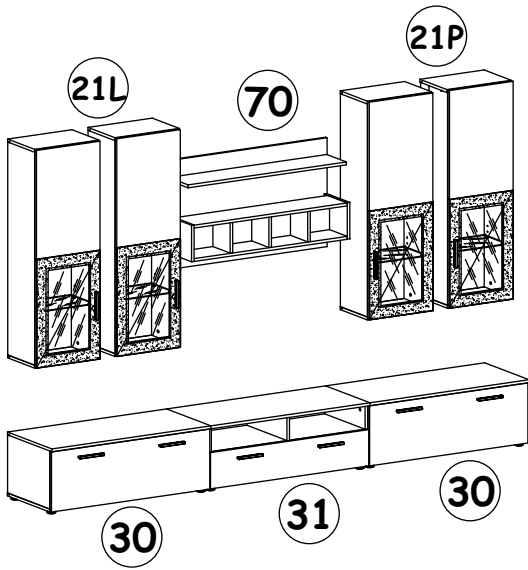
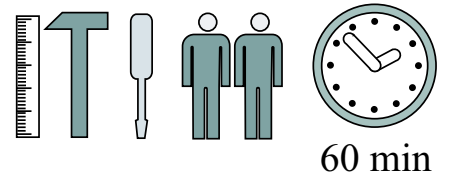

ABW LYRA TYP 21L

| | | | | | |
|--------------------|-----------------------|---------------------|------------------------|-------------------|------------------------|
| A1 X12 Ø8x36 | A4 X3 Ø6x36 | B5 X16 Ø15x12 | B4 X12 | G5 X16 | D10 X6 USØ3,5x13 |
| ZR1 X2 | D6 X4 USØ3,5x30 | G2 X1 | E1 X3 Ø26 H=0 | E2 X3 H=0 | Z2 X6 Ø5 |
| G20 X4 | G7 X4 | KL X1 L-128mm | UP6 X2 UPØ4x30 | S1 X8 | LED X1 |
| | | | | B6 X2 Ø7x78 | KR2 X2 |

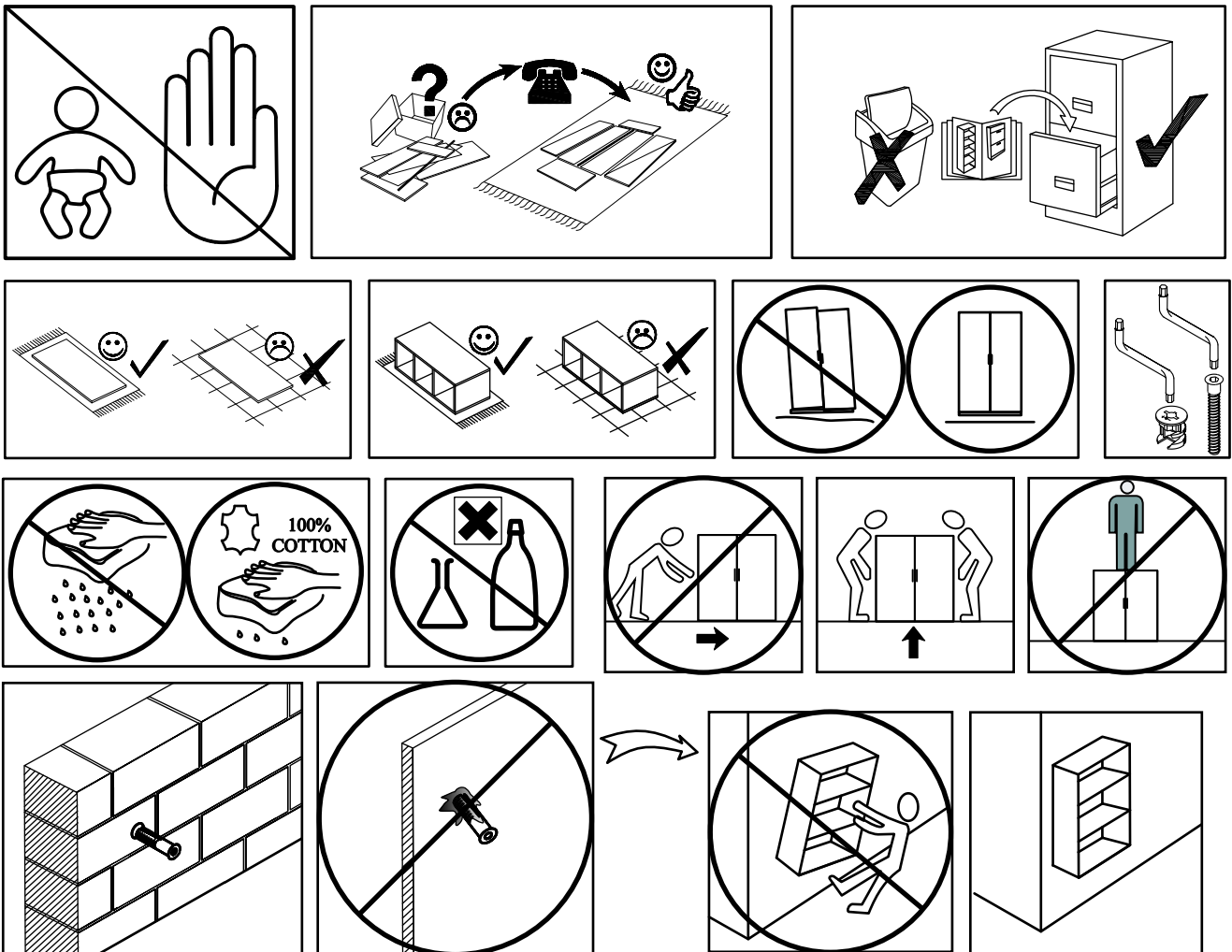
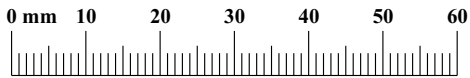

3

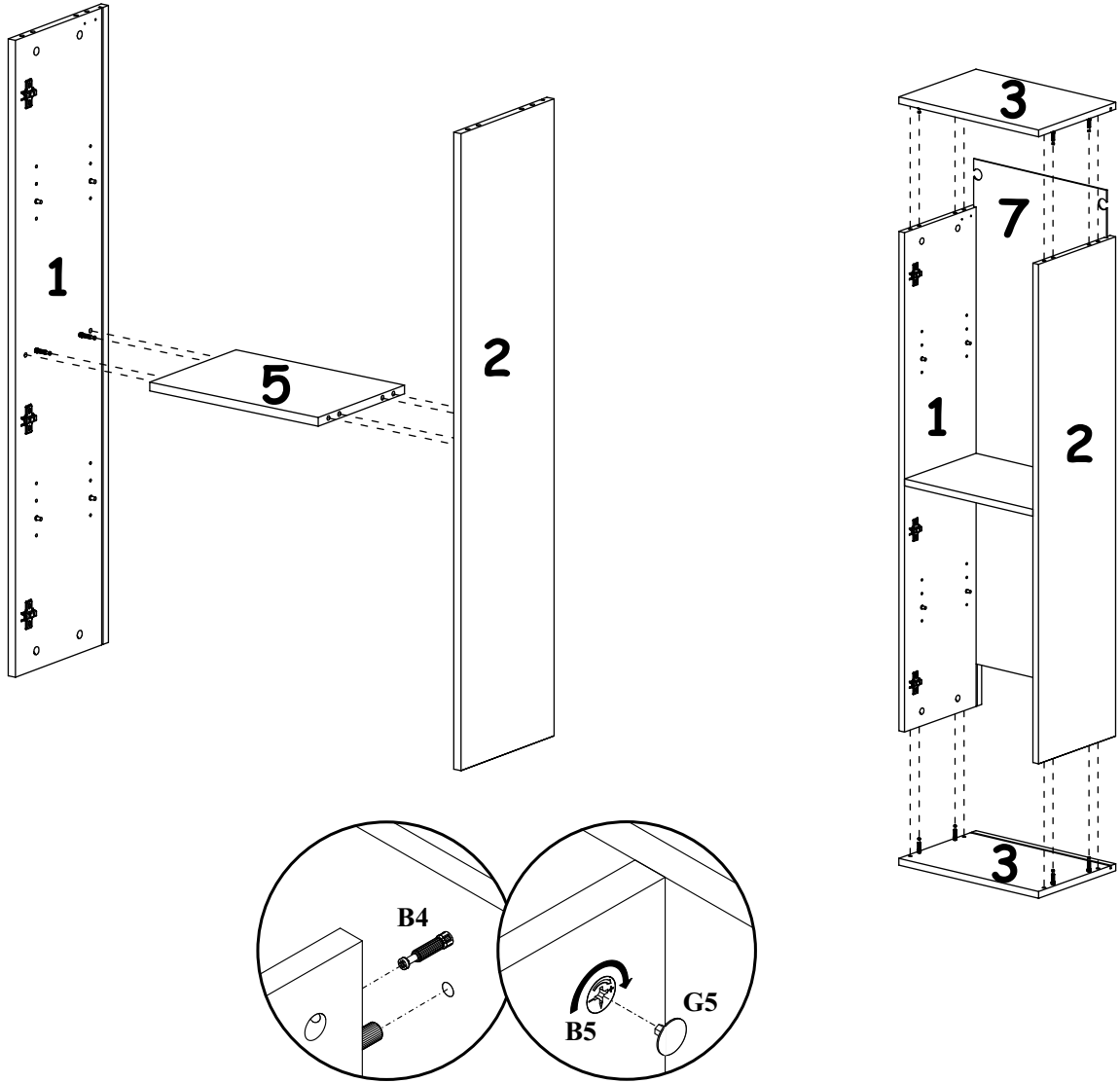

4

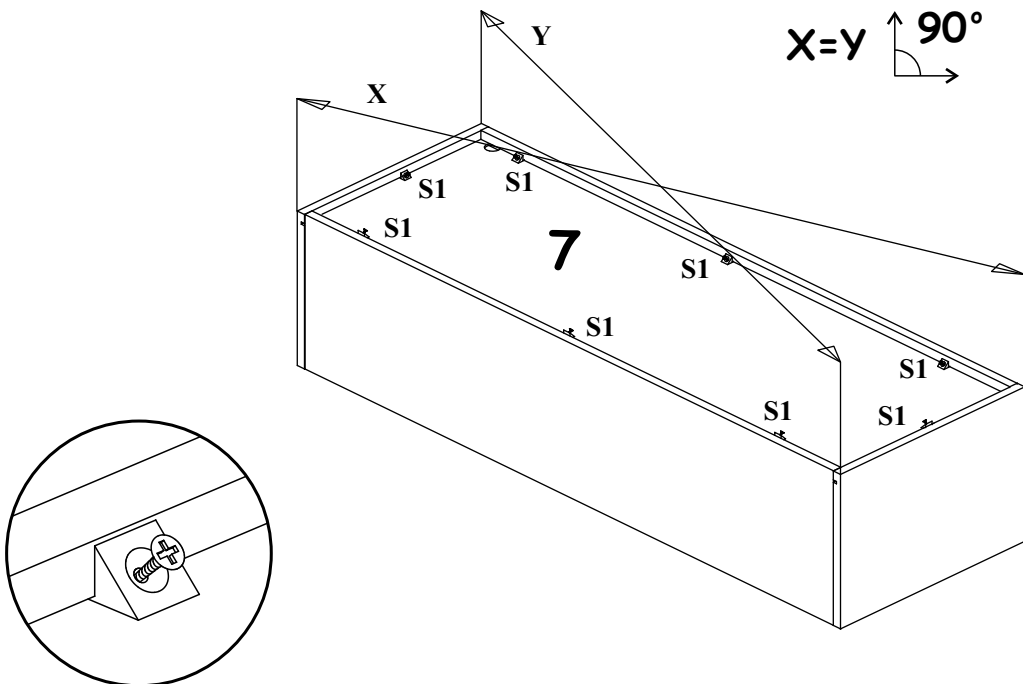

5

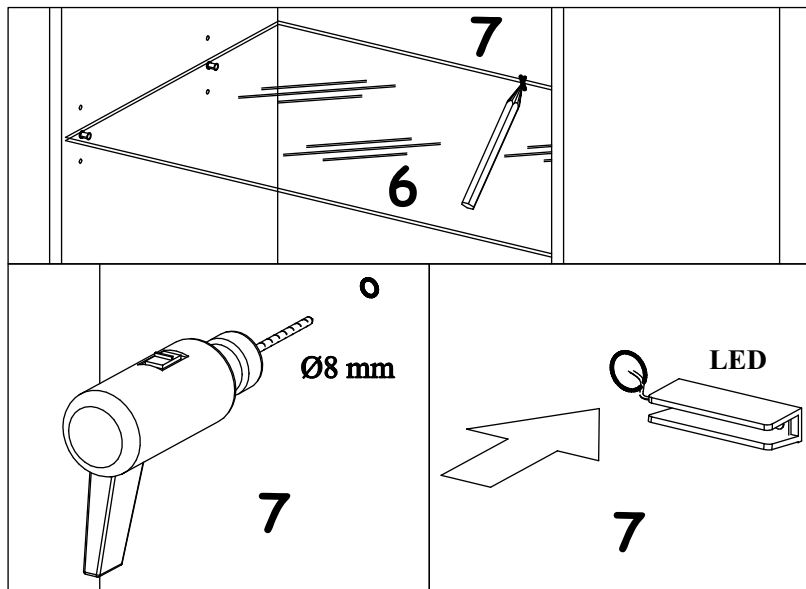
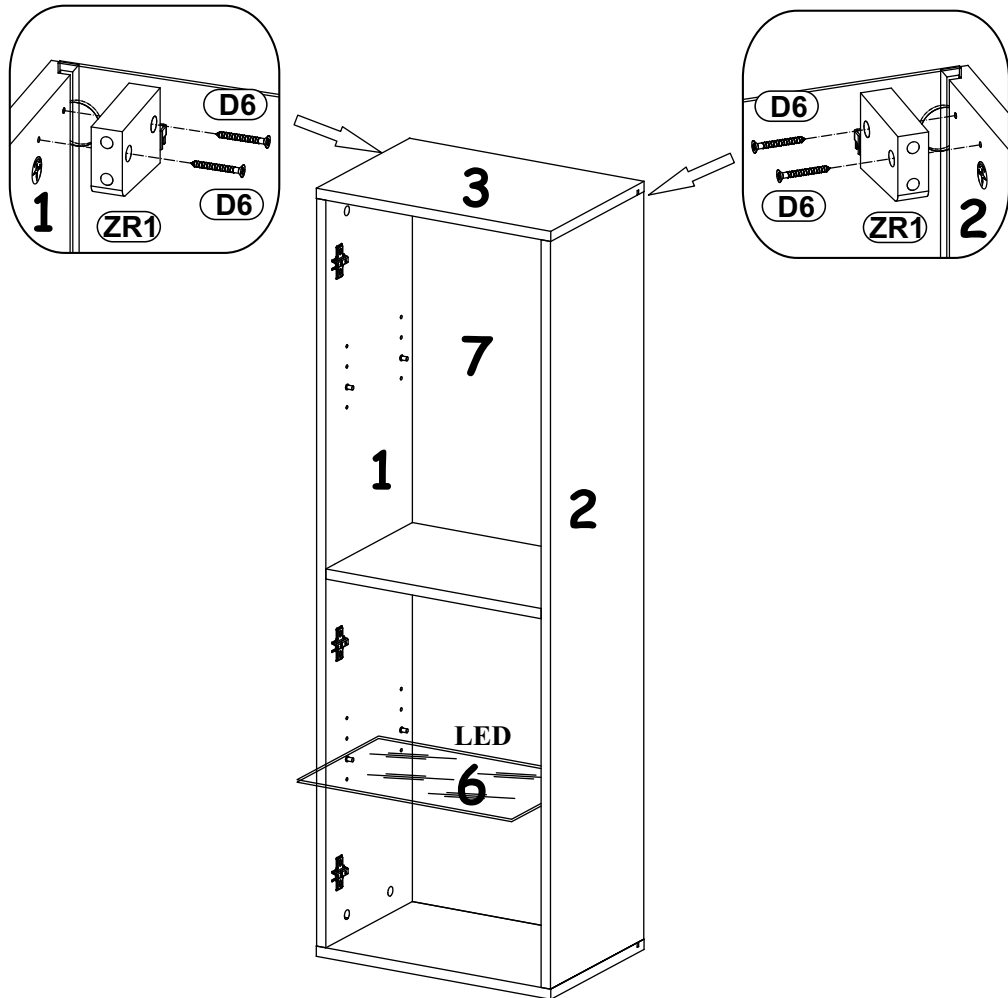

6

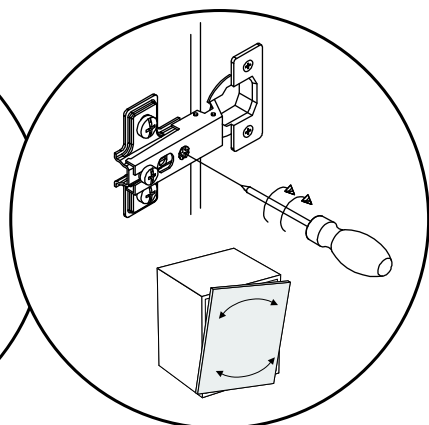
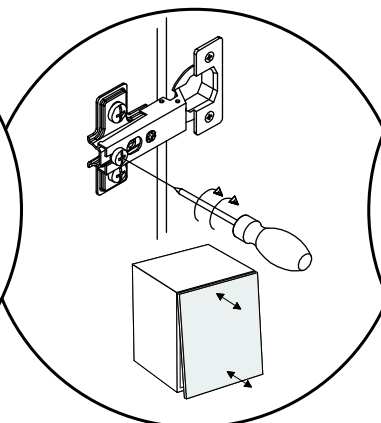
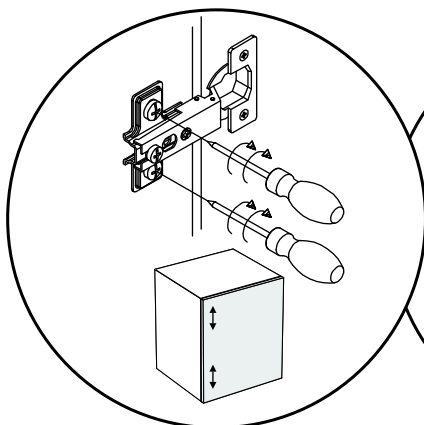
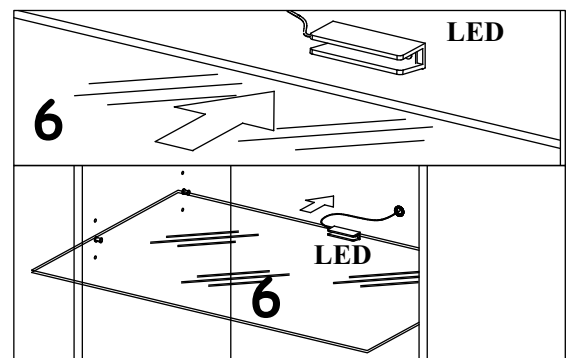
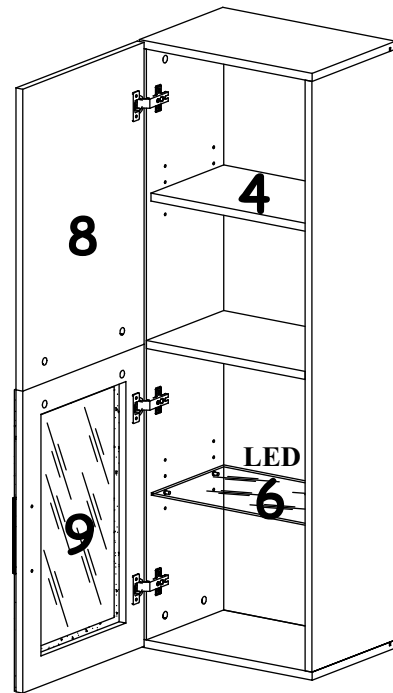
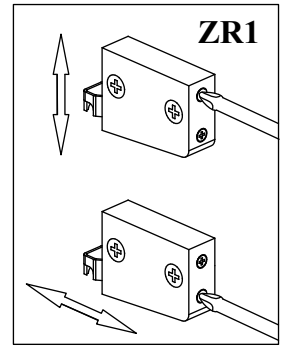
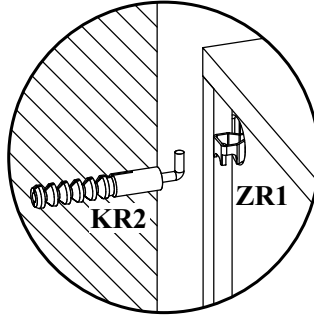
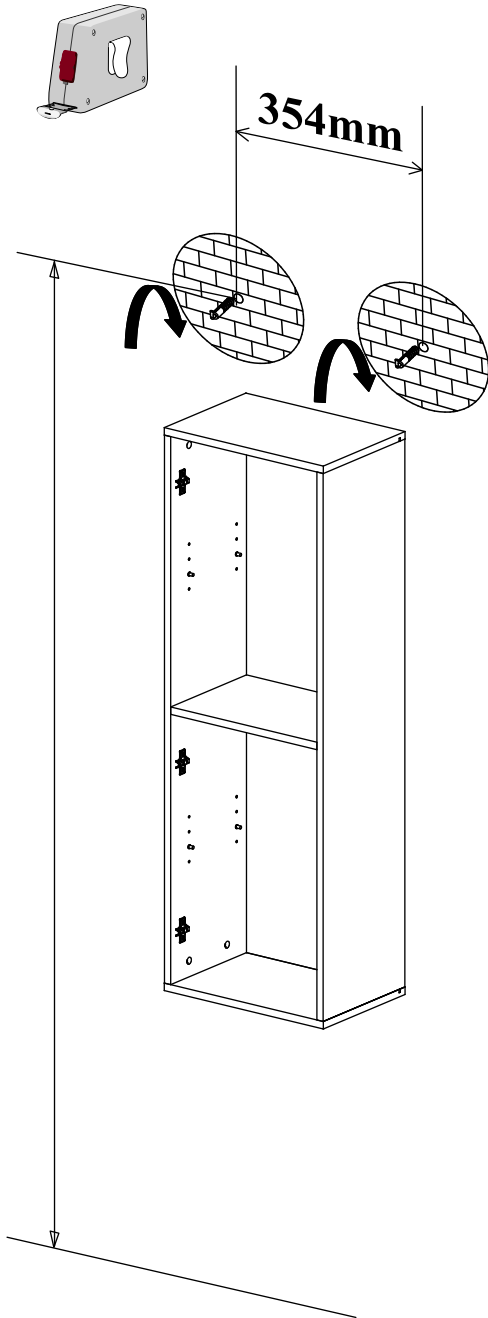

ABW LYRA TYP 21P

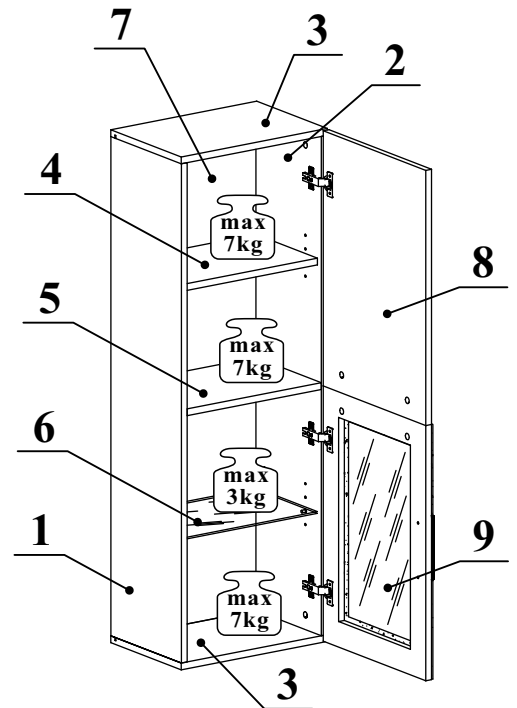
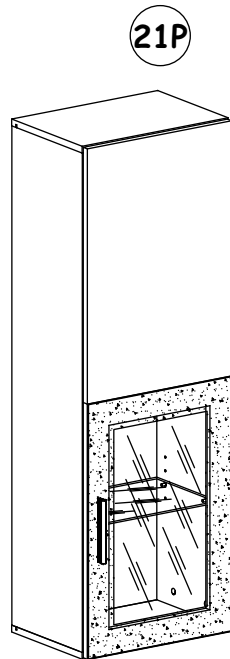
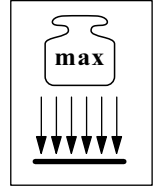
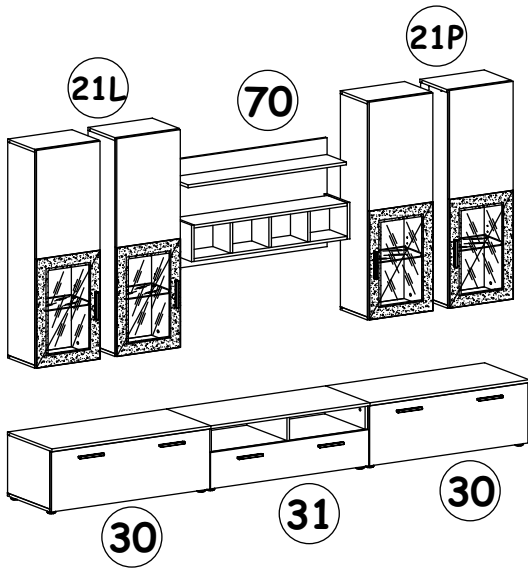

| NO | Dim. | | Col.-No | Qty |
|----|------|-----|---------|-----|
| 1 | 1174 | 275 | 1 | 1 |
| 2 | 1174 | 275 | 1 | 1 |
| 3 | 405 | 275 | 1 | 2 |
| 5 | 372 | 255 | 1 | 1 |
| 4 | 372 | 240 | 1 | 1 |
| 7 | 1186 | 385 | 1 | 1 |
| 6 | 371 | 240 | 1 | 1 |
| 8 | 400 | 600 | 1 | 1 |
| 9 | 400 | 600 | 1 | 1 |

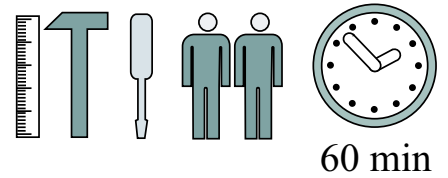

ABW LYRA TYP 21P

| | | | | | |
|--------------------|-----------------------|---------------------|------------------------|-------------------|------------------------|
| A1 X12 Ø8x36 | A4 X3 Ø6x36 | B5 X16 Ø15x12 | B4 X12 | G5 X16 | D10 X6 USØ3,5x13 |
| ZR1 X2 | D6 X4 USØ3,5x30 | G2 X1 | E1 X3 Ø26 H=0 | E2 X3 H=0 | Z2 X6 Ø5 |
| G20 X4 | G7 X4 | KL X1 L-128mm | UP6 X2 UPØ4x30 | S1 X8 | LED X1 |
| | | | | B6 X2 Ø7x78 | KR2 X2 |

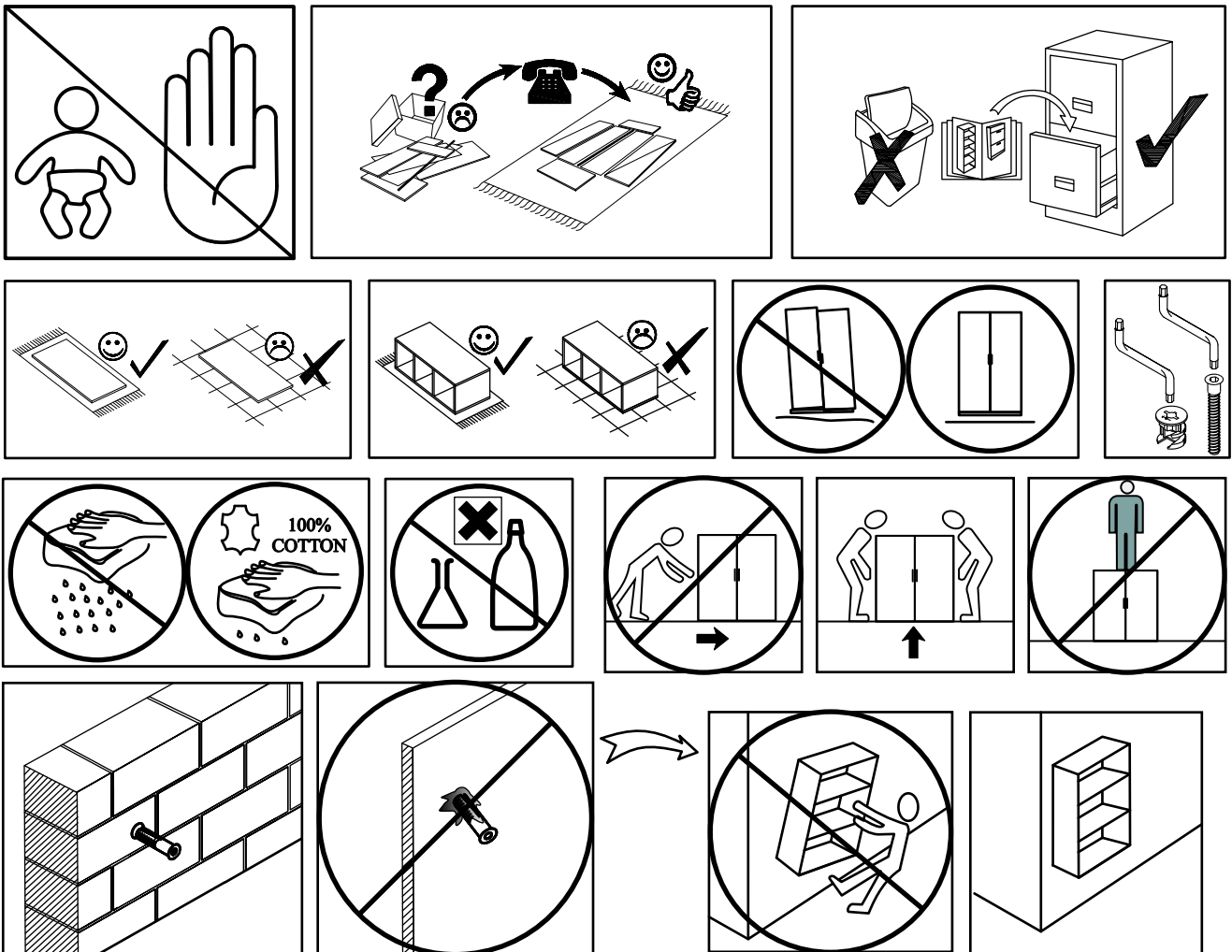
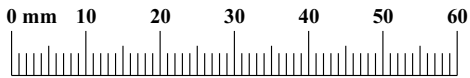

1

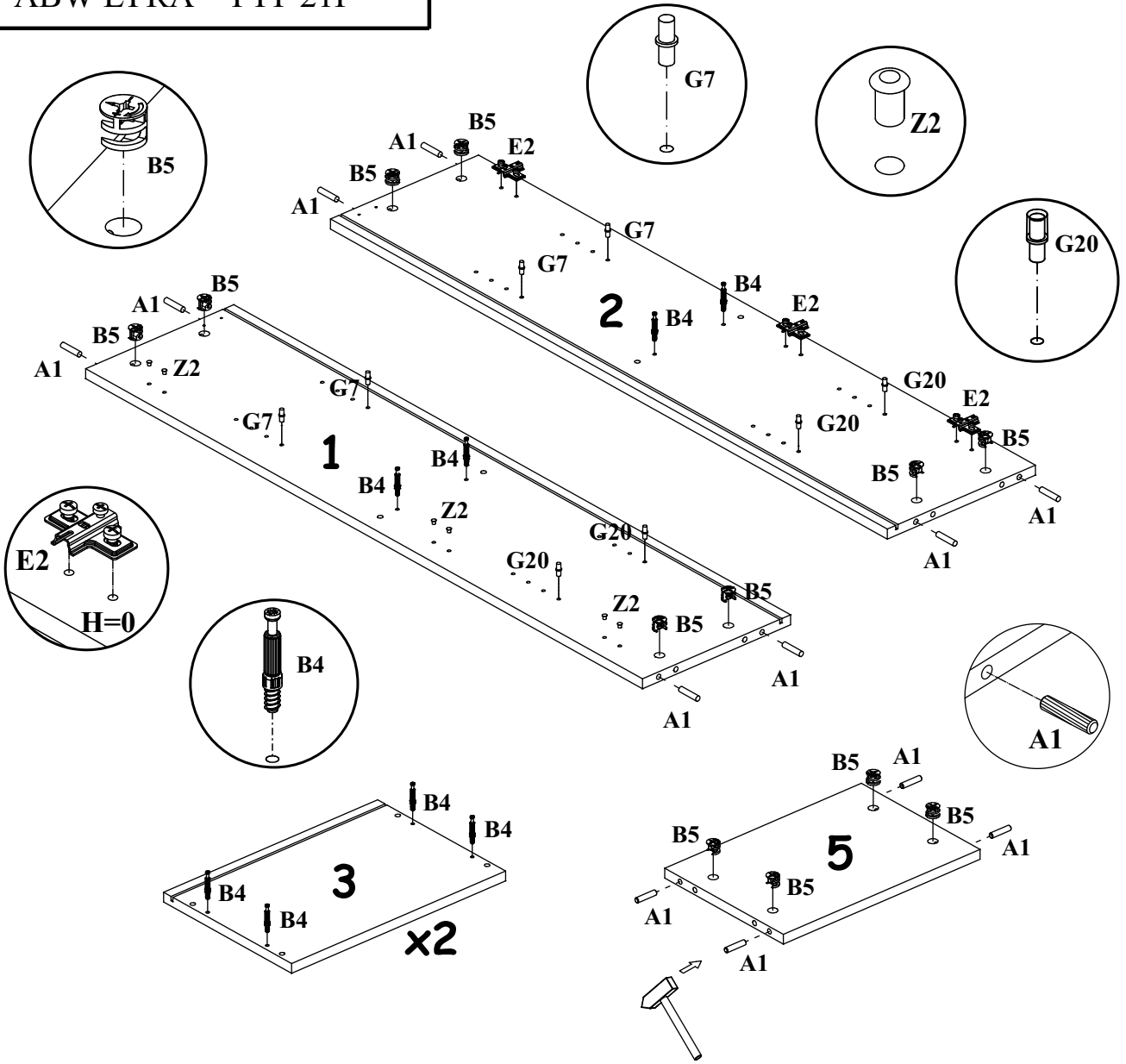

2

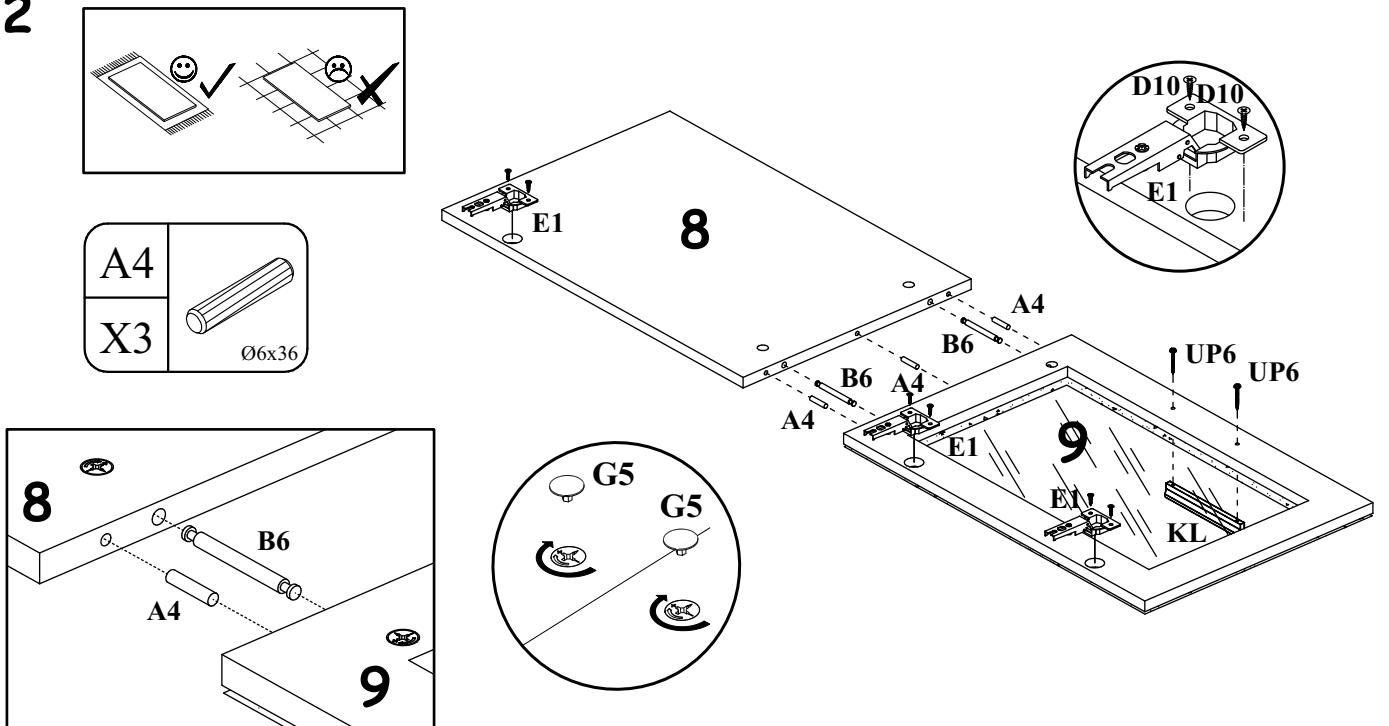

3

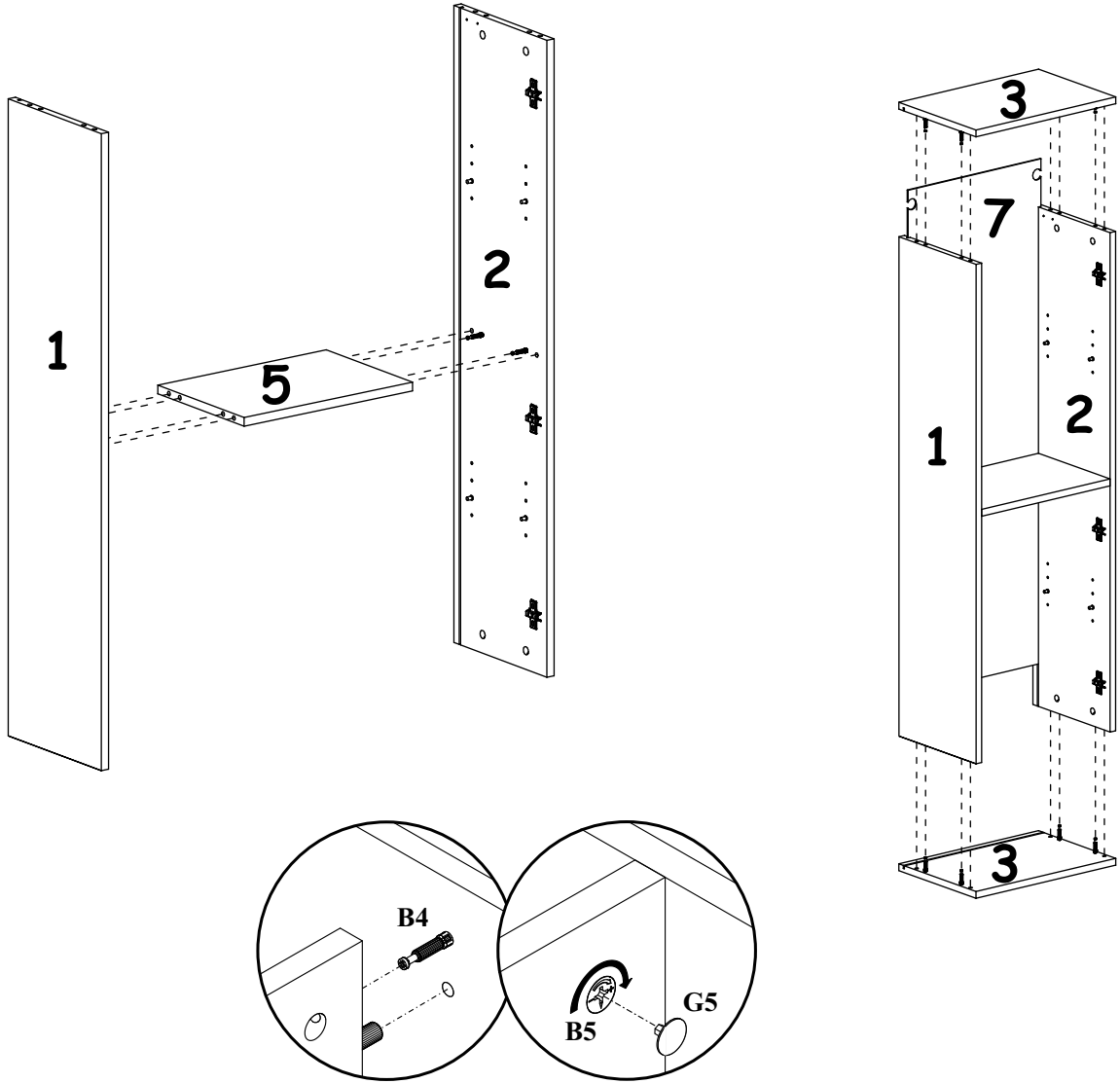

4

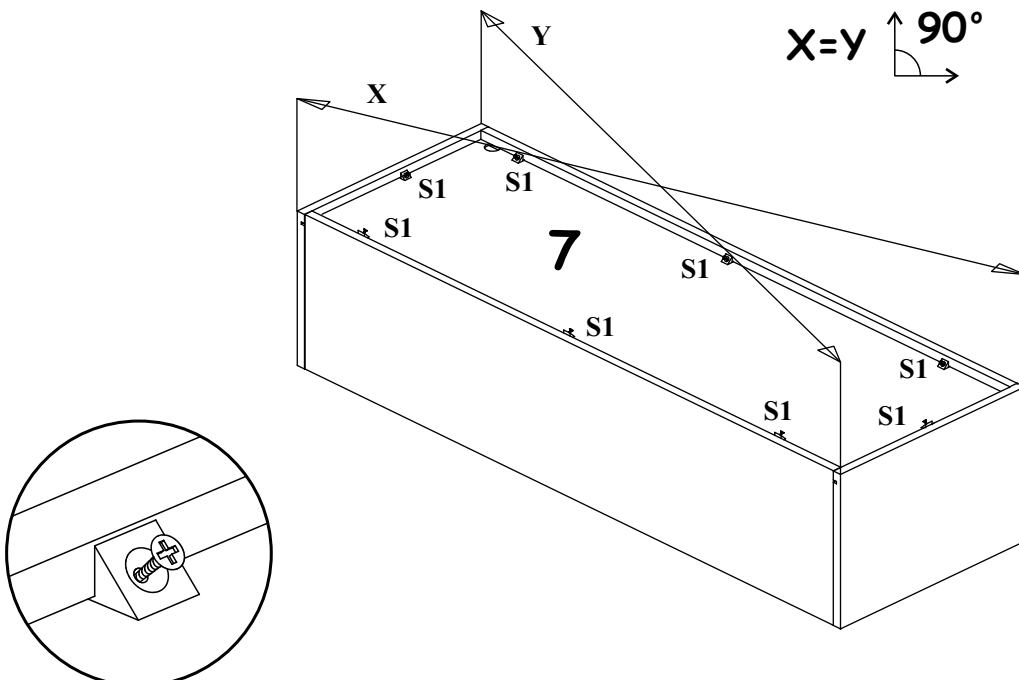

5

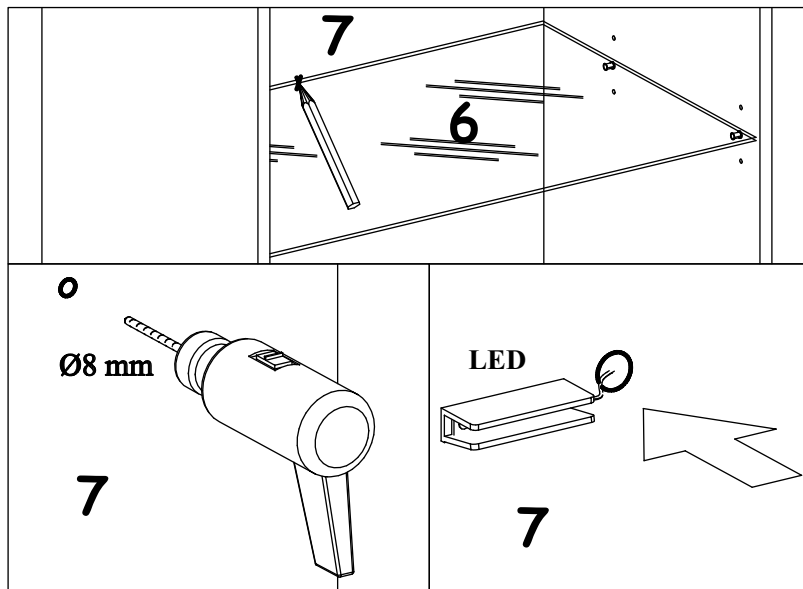
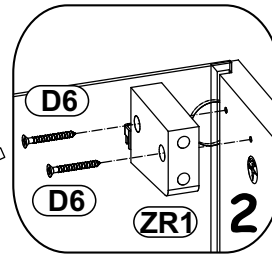
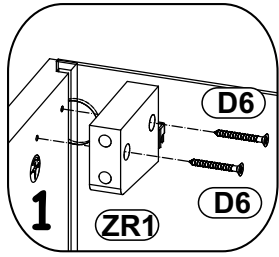
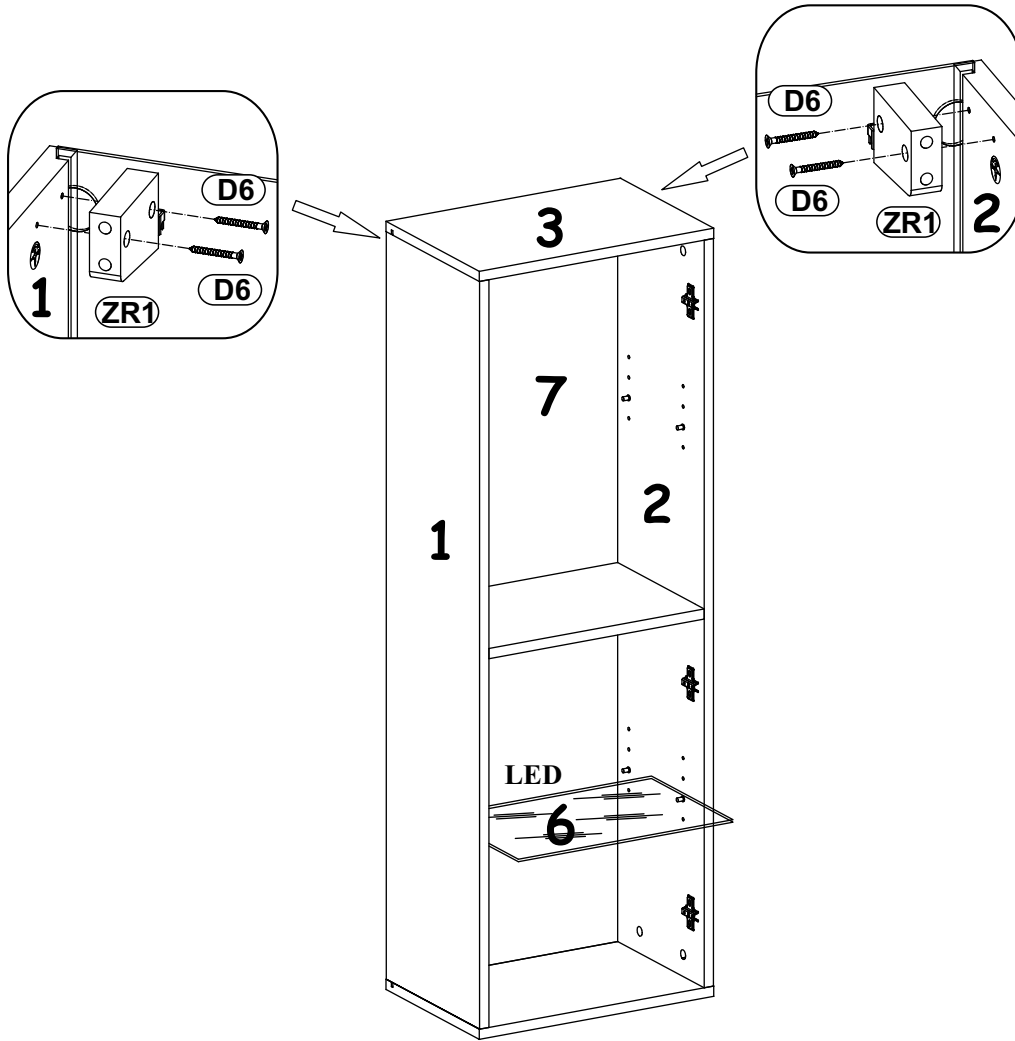

6

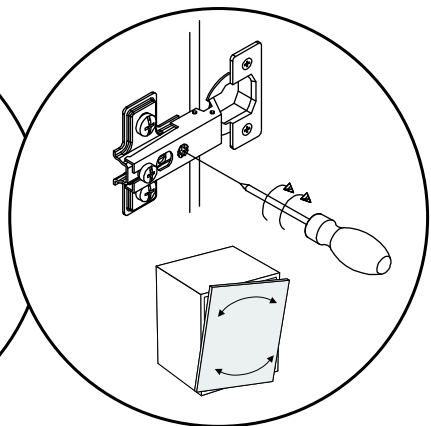
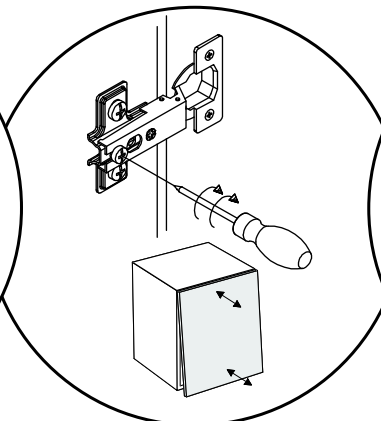
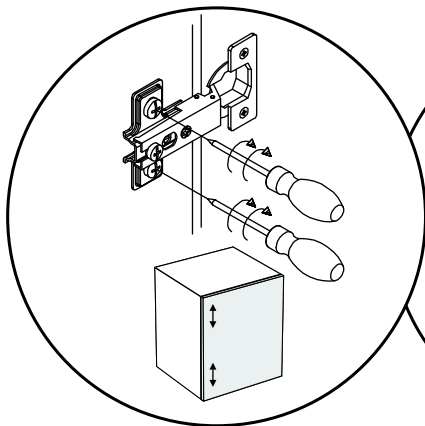
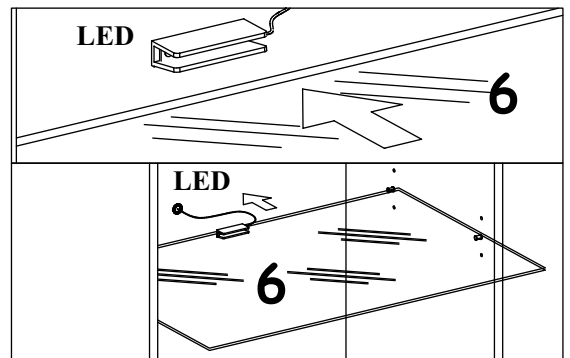
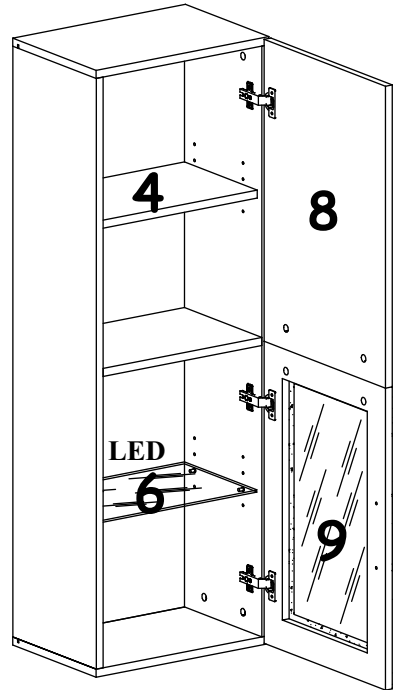
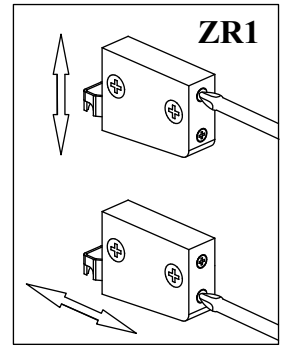
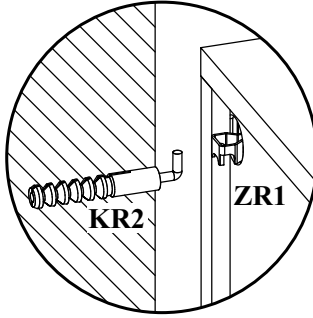
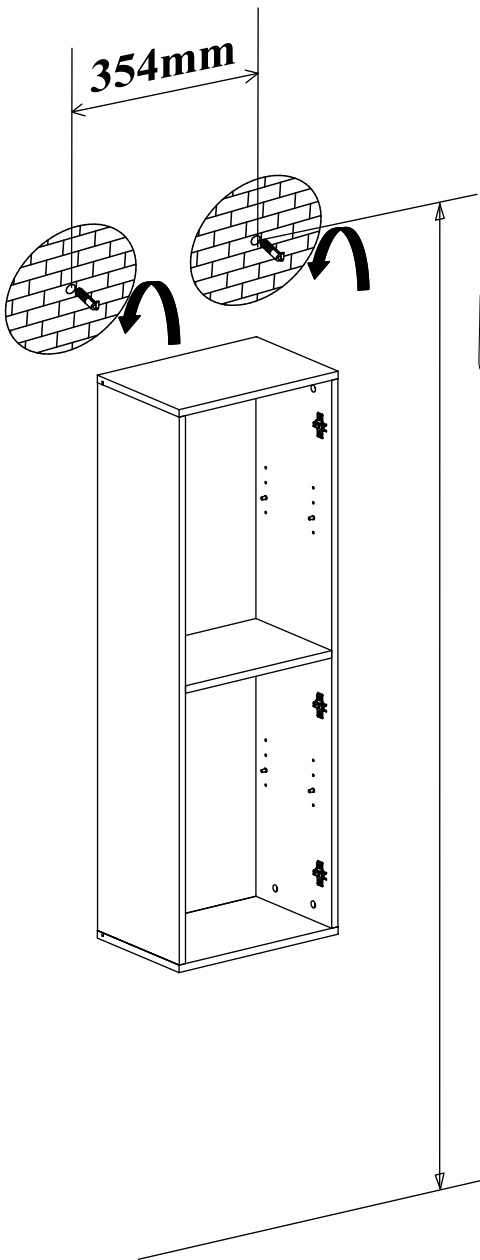

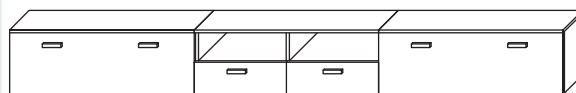
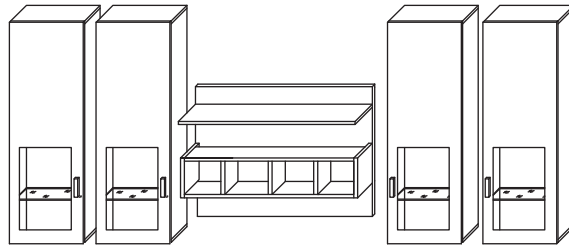
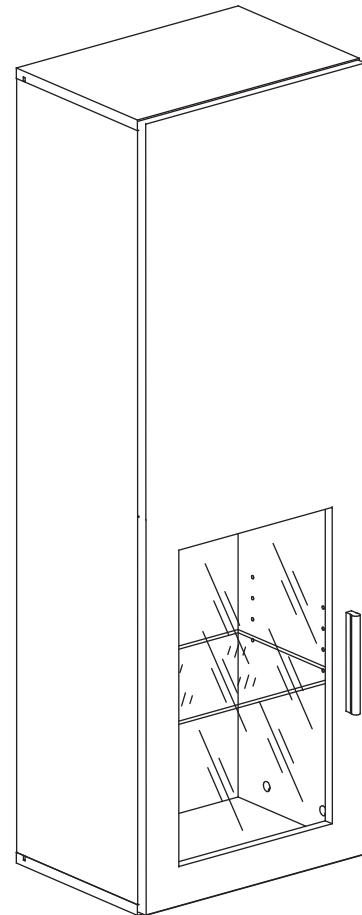
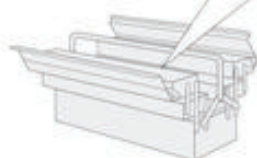
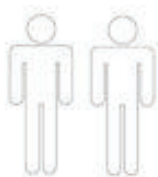
MODEL: LYRA**Nr. 22__LY****22L****22L 22L****22R 22R****30****31****30****(D) Montageanleitung****(GB) Assembly instructions****(NL) Handleiding voor de montage****(PL) Instrukcja montażu****(TR) Montaj talimatı****(RU) Инструкция по монтажу**

Sicherheitshinweise • Safety instructions • Veiligheidsinstructies •
Wskazówki bezpieczeństwa • Güvenlik uyarıları ? Правила техники безопасности

| | |
|-----------|--|
| D | Bitte nur mit einem Staubtuch oder leicht feuchtem Lappen reinigen. Keine scheuernden Putzmittel verwenden. |
| GB | Please only clean with a duster or a damp cloth. Do not use any abrasive cleaners. |
| NL | Reinig alleen met een stofdoek of een lichtjes vochtige doek. Gebruik geen schurende poetsmiddelen. |
| PL | Czyszczenie należy wykonać wyłącznie za pomocą ściereczki lub lekko nawilżonego ręcznika. Nie stosować środków czyszczących do szorowania. |
| TR | Lütfen sadece bir toz beziyle veya hafif nemli yumuşak bir bezle siliniz. Aşındırıcı temizlik malzemeleri kullanmayınız. |
| RU | Очищайте от пыли тряпкой или слегка влажной ветошью. Не допускается применение чистящих средств, не предназначенных для ухода за мебелью. |

| | |
|-----------|---|
| D | Das Produkt ist nicht für die Anwendung im Freien geeignet. |
| GB | The product is not suitable for outdoor use. |
| NL | Het product is niet geschikt voor het gebruik in open lucht. |
| PL | Produkt nie jest przystosowany do zastosowań na wolnym powietrzu. |
| TR | Bu ürün açık havada kullanılmaya uygun değildir. |
| RU | Изделие не предназначено для использования вне помещений. |

| | |
|-----------|--|
| D | Überschreiten Sie die angegebenen Maximalbelastungen nicht. Andernfalls kann das Möbelstück beschädigt oder zerstört werden. |
| GB | Do not exceed the maximum loads specified. Otherwise, the furniture may sustain damage or be irreparably damaged. |
| NL | Overschrijd de aangegeven maximale belastingen niet. Anders kan het meubelstuk worden beschadigd of vernield. |
| PL | Nie wolno przekraczać podanych maksymalnych wartości obciążenia. W innym przypadku można mebel uszkodzić lub zniszczyć. |
| TR | Belirtilen azami yük değerini aşmayınız, aksi takdirde mobilya parçası zarar görebilir veya kullanılamaz hale gelebilir. |
| RU | Не допускается превышение указанных максимальных нагрузок. В противном случае возможно повреждение или разрушение мебели. |

| | |
|-----------|--|
| D | Schützen Sie Ihre Möbel generell vor Wasser (z.B. beim Wischen oder Blumen gießen). Die Feuchtigkeit kann in das Möbelstück eindringen und es beschädigen |
| GB | In general, keep water away from your furniture (e. g. when mopping or watering plants). The moisture may penetrate the furniture and damage it. |
| NL | Bescherm uw meubelen doorgaans tegen water (bijv. bij het dweilen of als u de bloemen water geeft). De vochtigheid kan in het meubelstuk dringen en het beschadigen. |
| PL | Mebel należy chronić przed wodą (np. podczas czyszczenia lub podlewania kwiatków). Wilgoć może wnikać w mebel i uszkodzić go. |
| TR | Genelde mobilyalarınızı sudan koruyunuz (örneğin, yerleri paspaslarken veya çiçekleri sularken). Nem, mobilya parçasına nüfuz edebilir ve zarar verebilir. |
| RU | Предохраняйте мебель от попадания воды (например, при вытирании или поливке цветов). Не допускайте попадания влаги на мебель, чтобы предотвратить ее повреждение. |

| | |
|-----------|---|
| D | Der Artikel ist kein Kinderspielzeug! Lassen Sie Kinder auch nicht mit der Verpackung spielen. Sie könnten an der Folie ersticken oder sich an der Umverpackung verletzen. |
| GB | This product is not a toy! Do not allow children to play with the packaging. They could suffocate in the foil or injure themselves on the packaging. |
| NL | Het artikel is geen speelgoed voor kinderen! Zorg ervoor dat kinderen ook niet met de verpakking spelen. Ze kunnen stikken door de folie of zich verwonden aan de verpakking. |
| PL | Produkt nie służy do zabawy! Dzieci nie powinny bawić się opakowaniem produktu, gdyż mogą się udusić folią lub skaleczyć opakowaniem. |
| TR | Bu ürün bir çocuk oyuncakı değildir! Çocukların ürün ambalajlarıyla oynamalarına asla müsaade etmeyiniz. Çocuklar, folyo nedeniyle boğulabilir veya ambalaj nedeniyle yaralanabilirler. |
| RU | Не допускается игра детей с изделием! Не разрешайте детям играть с упаковочным материалом. Дети могут задохнуться в упаковочной пленке или пораниться упаковочным материалом. |

| | |
|-----------|---|
| D | Das Produkt ist nicht für die Anwendung im Freien geeignet. |
| GB | The product is not suitable for outdoor use. |
| NL | Het product is niet geschikt voor het gebruik in open lucht. |
| PL | Produkt nie jest przystosowany do zastosowań na wolnym powietrzu. |
| TR | Bu ürün açık havada kullanılmaya uygun değildir. |
| RU | Изделие не предназначено для использования вне помещений. |

| | |
|-----------|--|
| D | Überschreiten Sie die angegebenen Maximalbelastungen nicht. Andernfalls kann das Möbelstück beschädigt oder zerstört werden. |
| GB | Do not exceed the maximum loads specified. Otherwise, the furniture may sustain damage or be irreparably damaged. |
| NL | Overschrijd de aangegeven maximale belastingen niet. Anders kan het meubelstuk worden beschadigd of vernield. |
| PL | Nie wolno przekraczać podanych maksymalnych wartości obciążenia. W innym przypadku można mebel uszkodzić lub zniszczyć. |
| TR | Belirtilen azami yük değerini aşmayınız, aksi takdirde mobilya parçası zarar görebilir veya kullanılamaz hale gelebilir. |
| RU | Не допускается превышение указанных максимальных нагрузок. В противном случае возможно повреждение или разрушение мебели. |

| | |
|-----------|--|
| D | Schützen Sie Ihre Möbel generell vor Wasser (z.B. beim Wischen oder Blumen gießen). Die Feuchtigkeit kann in das Möbelstück eindringen und es beschädigen |
| GB | In general, keep water away from your furniture (e. g. when mopping or watering plants). The moisture may penetrate the furniture and damage it. |
| NL | Bescherm uw meubelen doorgaans tegen water (bijv. bij het dweilen of als u de bloemen water geeft). De vochtigheid kan in het meubelstuk dringen en het beschadigen. |
| PL | Mebel należy chronić przed wodą (np. podczas czyszczenia lub podlewania kwiatków). Wilgoć może wnikać w mebel i uszkodzić go. |
| TR | Genelde mobilyalarınızı sudan koruyunuz (örneğin, yerleri paspaslarken veya çiçekleri sularken). Nem, mobilya parçasına nüfuz edebilir ve zarar verebilir. |
| RU | Предохраняйте мебель от попадания воды (например, при вытирании или поливке цветов). Не допускайте попадания влаги на мебель, чтобы предотвратить ее повреждение. |

| | |
|-----------|---|
| D | Der Artikel ist kein Kinderspielzeug! Lassen Sie Kinder auch nicht mit der Verpackung spielen. Sie könnten an der Folie ersticken oder sich an der Umverpackung verletzen. |
| GB | This product is not a toy! Do not allow children to play with the packaging. They could suffocate in the foil or injure themselves on the packaging. |
| NL | Het artikel is geen speelgoed voor kinderen! Zorg ervoor dat kinderen ook niet met de verpakking spelen. Ze kunnen stikken door de folie of zich verwonden aan de verpakking. |
| PL | Produkt nie służy do zabawy! Dzieci nie powinny bawić się opakowaniem produktu, gdyż mogą się udusić folią lub skaleczyć opakowaniem. |
| TR | Bu ürün bir çocuk oyuncakı değildir! Çocukların ürün ambalajlarıyla oynamalarına asla müsaade etmeyiniz. Çocuklar, folyo nedeniyle boğulabilir veya ambalaj nedeniyle yaralanabilirler. |
| RU | Не допускается игра детей с изделием! Не разрешайте детям играть с упаковочным материалом. Дети могут задохнуться в упаковочной пленке или пораниться упаковочным материалом. |

Service • Dienstverlening • Serwis • Servis • Сервисная служба

Name • Naam • Nazwa • Isim • Название

LYRA

Nr. • No. • Номер

22 LY

Typ • Type • Тип • Тип

22L

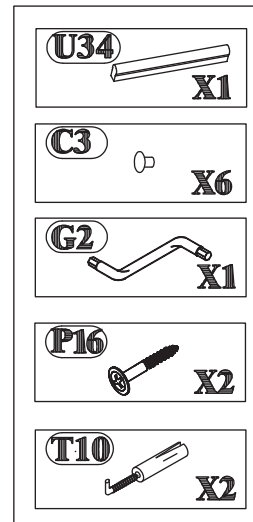
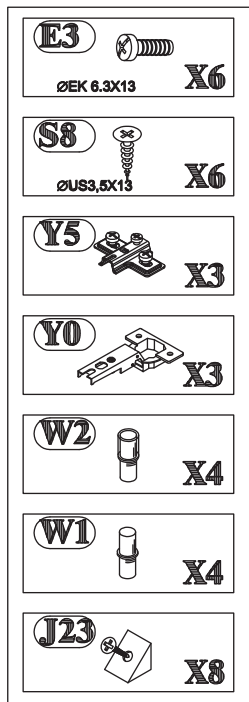
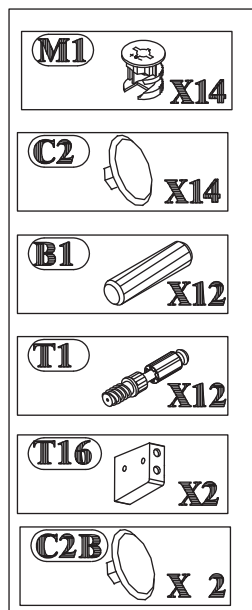
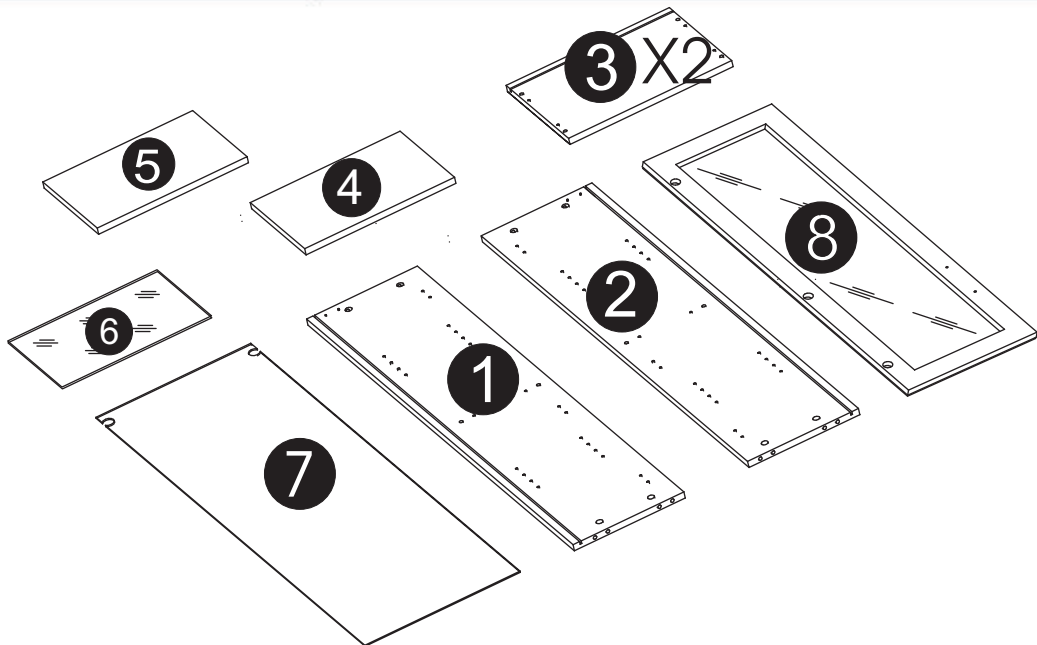
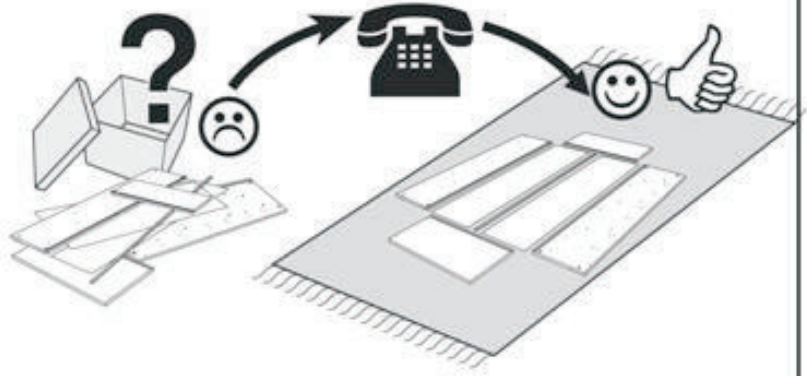
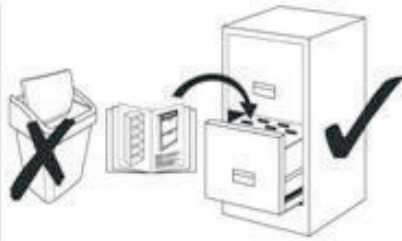

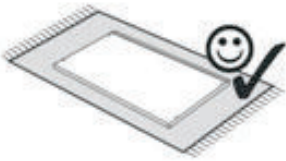

1

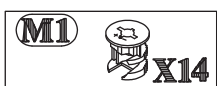
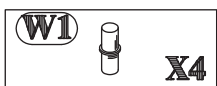
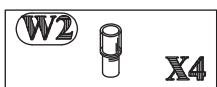
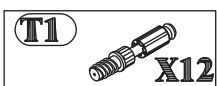
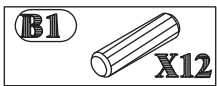
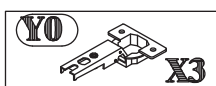
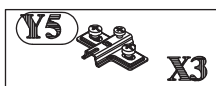
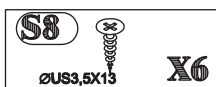
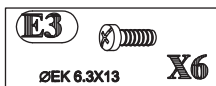
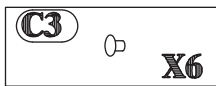
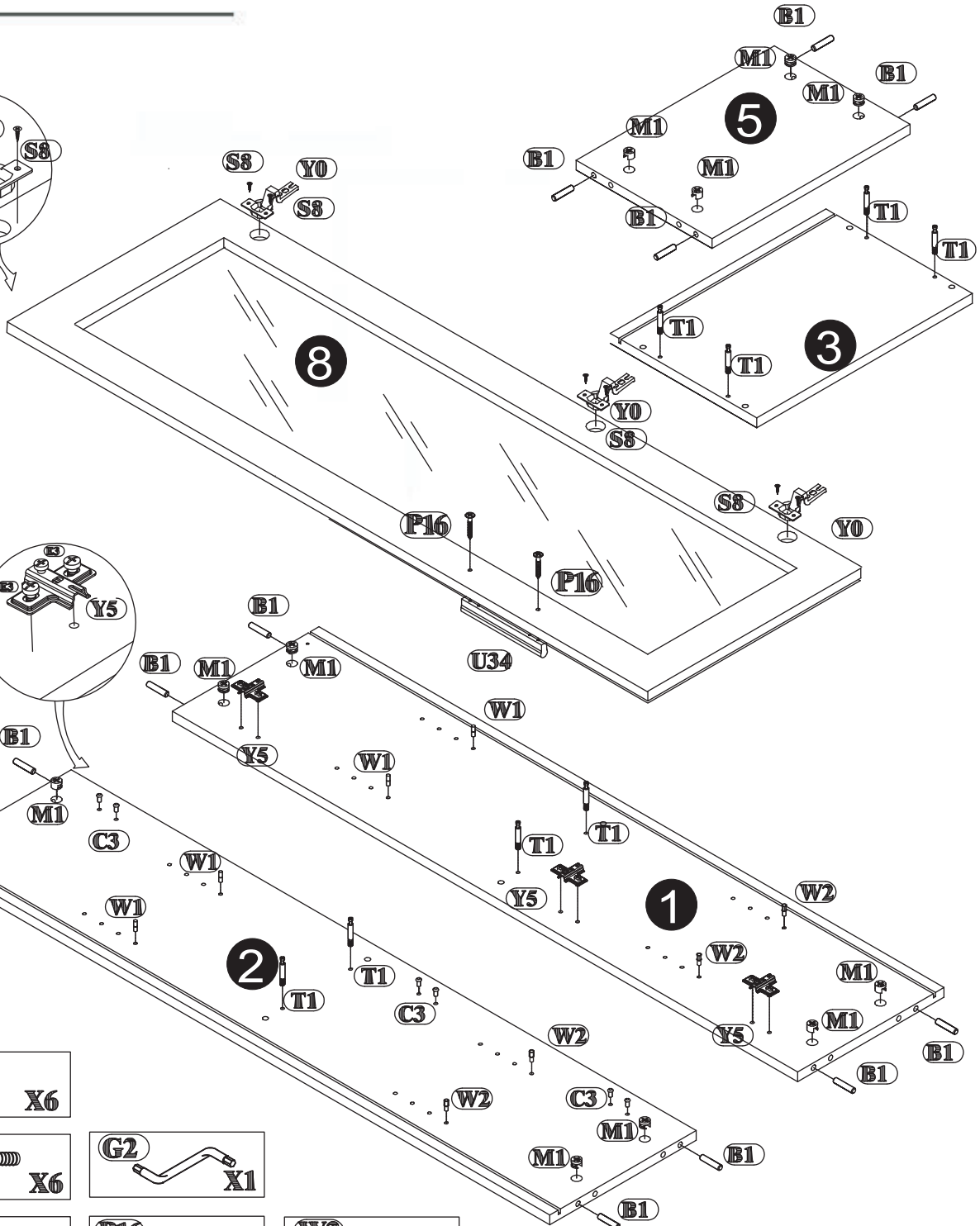
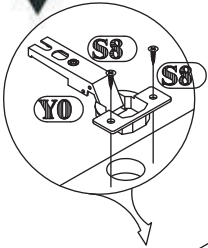

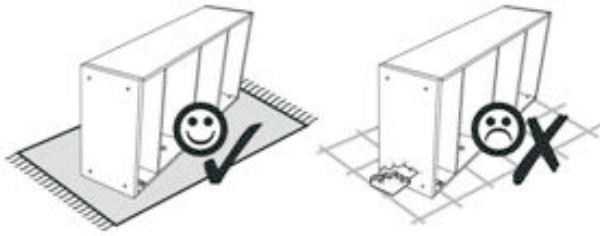

2

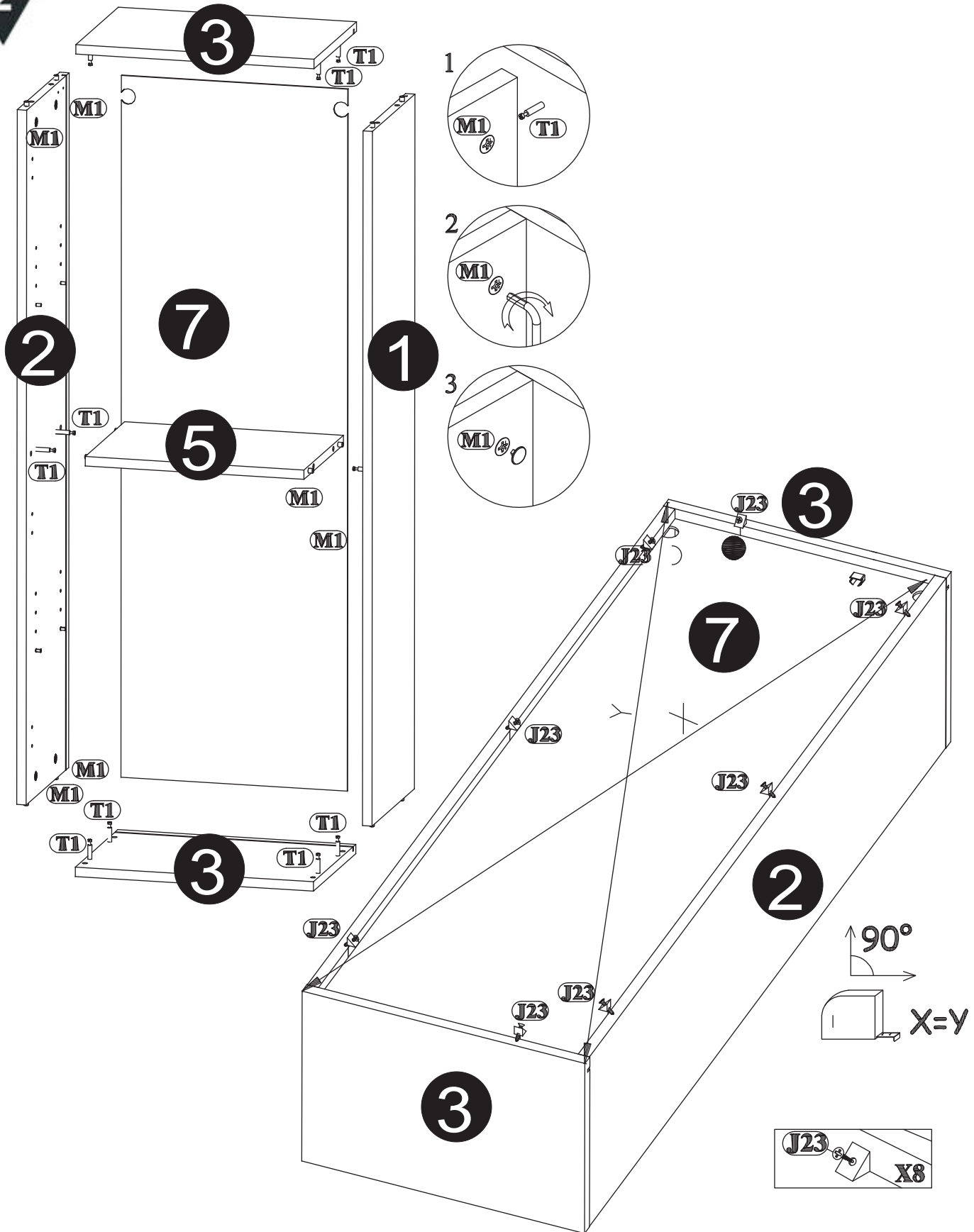



3

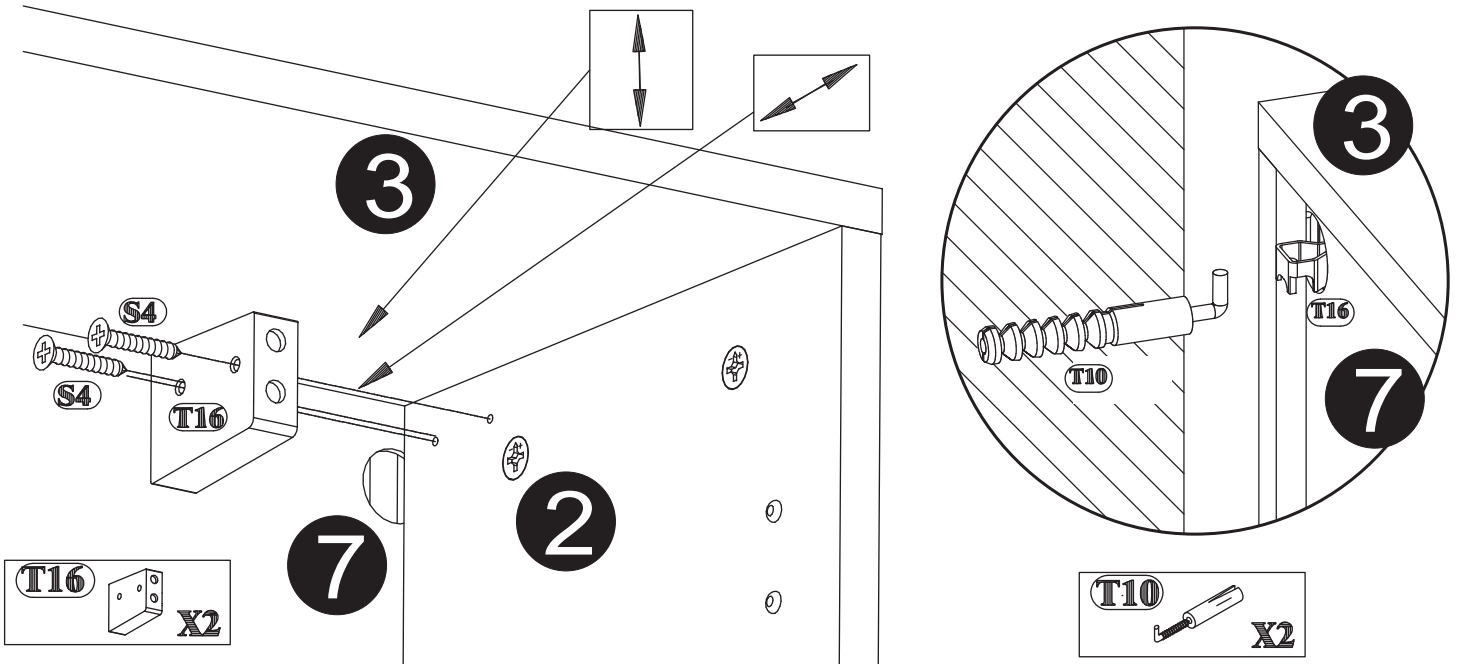

T16 X2

T10 X2

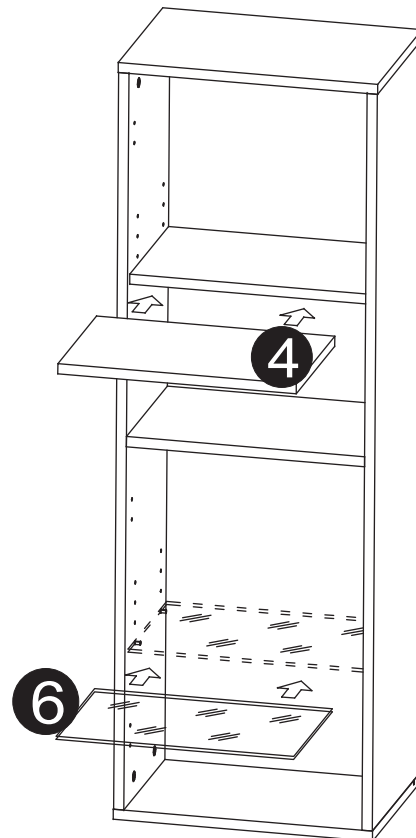
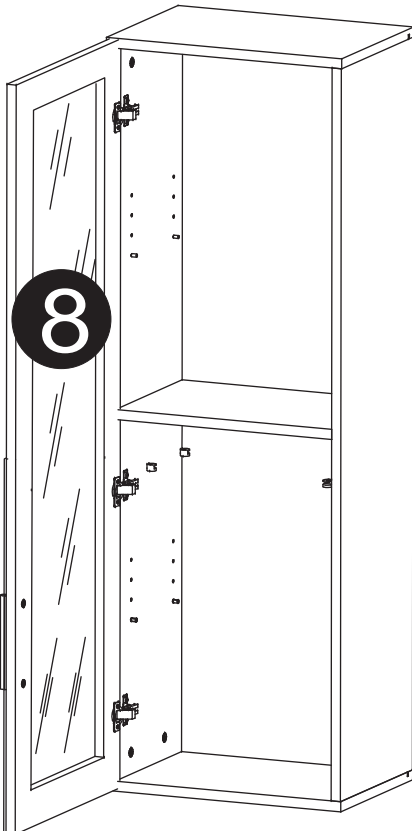

Türen einstellen (Scharniere justieren)

Adjusting the doors (adjusting the hinges)

Deuren instellen (scharnieren afstellen)

Nastawić drzwi (wyrównać zawiasy)

Kapıların ayarlanması (mentşelerin seviye ayarı)

Регулировка дверей (регулировка шарнира)

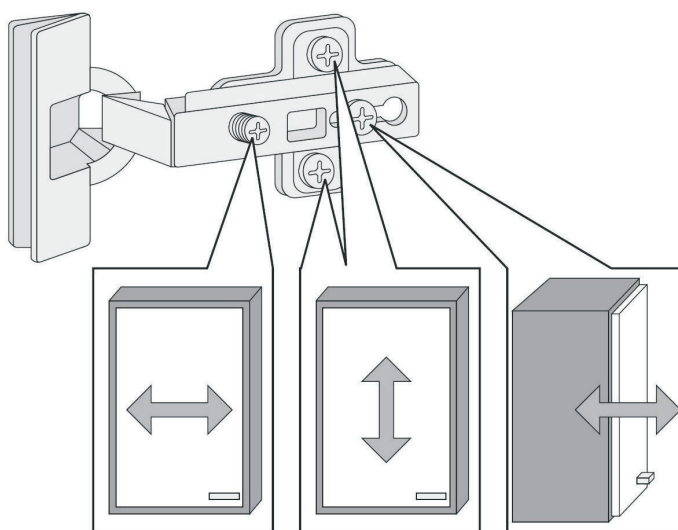

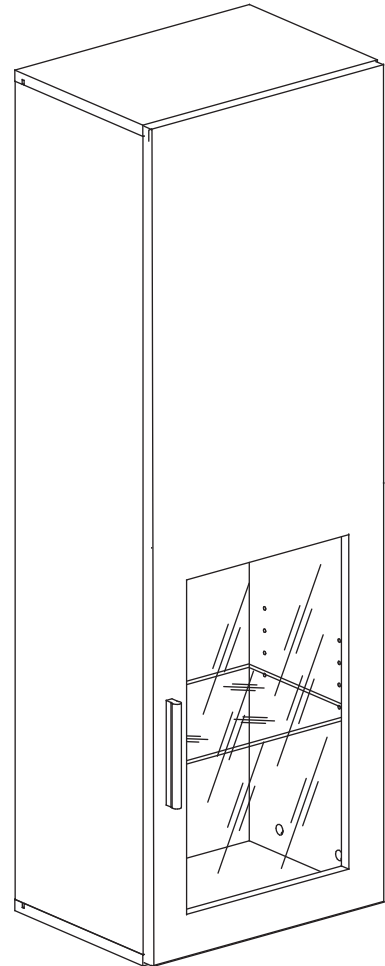
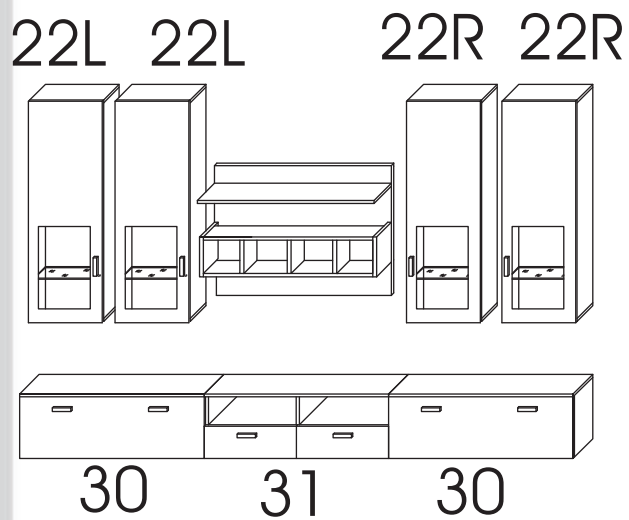
MODEL: LYRA**Nr. 22__LY****22R**

(D) Montageanleitung

(GB) Assembly instructions

(NL) Handleiding voor de montage

(PL) Instrukcja montażu

(TR) Montaj talimatı

(RU) Инструкция по монтажу

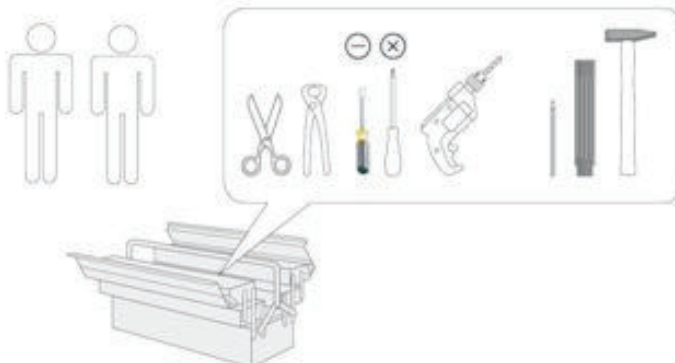

Sicherheitshinweise • Safety instructions • Veiligheidsinstructies •
Wskazówki bezpieczeństwa • Güvenlik uyarıları ? Правила техники безопасности

| | |
|-----------|--|
| D | Bitte nur mit einem Staubtuch oder leicht feuchtem Lappen reinigen. Keine scheuernden Putzmittel verwenden. |
| GB | Please only clean with a duster or a damp cloth. Do not use any abrasive cleaners. |
| NL | Reinig alleen met een stofdoek of een lichtjes vochtige doek. Gebruik geen schurende poetsmiddelen. |
| PL | Czyszczenie należy wykonać wyłącznie za pomocą ściereczki lub lekko nawilżonego ręcznika. Nie stosować środków czyszczących do szorowania. |
| TR | Lütfen sadece bir toz beziyle veya hafif nemli yumuşak bir bezle siliniz. Aşındırıcı temizlik malzemeleri kullanmayınız. |
| RU | Очищайте от пыли тряпкой или слегка влажной ветошью. Не допускается применение чистящих средств, не предназначенных для ухода за мебелью. |

| | |
|-----------|---|
| D | Das Produkt ist nicht für die Anwendung im Freien geeignet. |
| GB | The product is not suitable for outdoor use. |
| NL | Het product is niet geschikt voor het gebruik in open lucht. |
| PL | Produkt nie jest przystosowany do zastosowań na wolnym powietrzu. |
| TR | Bu ürün açık havada kullanılmaya uygun değildir. |
| RU | Изделие не предназначено для использования вне помещений. |

| | |
|-----------|--|
| D | Überschreiten Sie die angegebenen Maximalbelastungen nicht. Andernfalls kann das Möbelstück beschädigt oder zerstört werden. |
| GB | Do not exceed the maximum loads specified. Otherwise, the furniture may sustain damage or be irreparably damaged. |
| NL | Overschrijd de aangegeven maximale belastingen niet. Anders kan het meubelstuk worden beschadigd of vernield. |
| PL | Nie wolno przekraczać podanych maksymalnych wartości obciążenia. W innym przypadku można mebel uszkodzić lub zniszczyć. |
| TR | Belirtilen azami yük değerini aşmayınız, aksi takdirde mobilya parçası zarar görebilir veya kullanılamaz hale gelebilir. |
| RU | Не допускается превышение указанных максимальных нагрузок. В противном случае возможно повреждение или разрушение мебели. |

| | |
|-----------|--|
| D | Schützen Sie Ihre Möbel generell vor Wasser (z.B. beim Wischen oder Blumen gießen). Die Feuchtigkeit kann in das Möbelstück eindringen und es beschädigen |
| GB | In general, keep water away from your furniture (e. g. when mopping or watering plants). The moisture may penetrate the furniture and damage it. |
| NL | Bescherm uw meubelen doorgaans tegen water (bijv. bij het dweilen of als u de bloemen water geeft). De vochtigheid kan in het meubelstuk dringen en het beschadigen. |
| PL | Mebel należy chronić przed wodą (np. podczas czyszczenia lub podlewania kwiatków). Wilgoć może wnikać w mebel i uszkodzić go. |
| TR | Genelde mobilyalarınızı sudan koruyunuz (örneğin, yerleri paspaslarken veya çiçekleri sularken). Nem, mobilya parçasına nüfuz edebilir ve zarar verebilir. |
| RU | Предохраняйте мебель от попадания воды (например, при вытирании или поливке цветов). Не допускайте попадания влаги на мебель, чтобы предотвратить ее повреждение. |

| | |
|-----------|---|
| D | Der Artikel ist kein Kinderspielzeug! Lassen Sie Kinder auch nicht mit der Verpackung spielen. Sie könnten an der Folie ersticken oder sich an der Umverpackung verletzen. |
| GB | This product is not a toy! Do not allow children to play with the packaging. They could suffocate in the foil or injure themselves on the packaging. |
| NL | Het artikel is geen speelgoed voor kinderen! Zorg ervoor dat kinderen ook niet met de verpakking spelen. Ze kunnen stikken door de folie of zich verwonden aan de verpakking. |
| PL | Produkt nie służy do zabawy! Dzieci nie powinny bawić się opakowaniem produktu, gdyż mogą się udusić folią lub skaleczyć opakowaniem. |
| TR | Bu ürün bir çocuk oyuncakı değildir! Çocukların ürün ambalajlarıyla oynamalarına asla müsaade etmeyiniz. Çocuklar, folyo nedeniyle boğulabilir veya ambalaj nedeniyle yaralanabilirler. |
| RU | Не допускается игра детей с изделием! Не разрешайте детям играть с упаковочным материалом. Дети могут задохнуться в упаковочной пленке или пораниться упаковочным материалом. |

| | |
|-----------|---|
| D | Das Produkt ist nicht für die Anwendung im Freien geeignet. |
| GB | The product is not suitable for outdoor use. |
| NL | Het product is niet geschikt voor het gebruik in open lucht. |
| PL | Produkt nie jest przystosowany do zastosowań na wolnym powietrzu. |
| TR | Bu ürün açık havada kullanılmaya uygun değildir. |
| RU | Изделие не предназначено для использования вне помещений. |

| | |
|-----------|--|
| D | Überschreiten Sie die angegebenen Maximalbelastungen nicht. Andernfalls kann das Möbelstück beschädigt oder zerstört werden. |
| GB | Do not exceed the maximum loads specified. Otherwise, the furniture may sustain damage or be irreparably damaged. |
| NL | Overschrijd de aangegeven maximale belastingen niet. Anders kan het meubelstuk worden beschadigd of vernield. |
| PL | Nie wolno przekraczać podanych maksymalnych wartości obciążenia. W innym przypadku można mebel uszkodzić lub zniszczyć. |
| TR | Belirlenen azami yük değerini aşmayınız, aksi takdirde mobilya parçası zarar görebilir veya kullanılamaz hale gelebilir. |
| RU | Не допускается превышение указанных максимальных нагрузок. В противном случае возможно повреждение или разрушение мебели. |

| | |
|-----------|--|
| D | Schützen Sie Ihre Möbel generell vor Wasser (z.B. beim Wischen oder Blumen gießen). Die Feuchtigkeit kann in das Möbelstück eindringen und es beschädigen |
| GB | In general, keep water away from your furniture (e. g. when mopping or watering plants). The moisture may penetrate the furniture and damage it. |
| NL | Bescherm uw meubelen doorgaans tegen water (bijv. bij het dweilen of als u de bloemen water geeft). De vochtigheid kan in het meubelstuk dringen en het beschadigen. |
| PL | Mebel należy chronić przed wodą (np. podczas czyszczenia lub podlewania kwiatków). Wilgoć może wnikać w mebel i uszkodzić go. |
| TR | Genelde mobilyalarınızı sudan koruyunuz (örneğin, yerleri paspaslarken veya çiçekleri sularken). Nem, mobilya parçasına nüfuz edebilir ve zarar verebilir. |
| RU | Предохраняйте мебель от попадания воды (например, при вытирании или поливке цветов). Не допускайте попадания влаги на мебель, чтобы предотвратить ее повреждение. |

| | |
|-----------|---|
| D | Der Artikel ist kein Kinderspielzeug! Lassen Sie Kinder auch nicht mit der Verpackung spielen. Sie könnten an der Folie ersticken oder sich an der Umverpackung verletzen. |
| GB | This product is not a toy! Do not allow children to play with the packaging. They could suffocate in the foil or injure themselves on the packaging. |
| NL | Het artikel is geen speelgoed voor kinderen! Zorg ervoor dat kinderen ook niet met de verpakking spelen. Ze kunnen stikken door de folie of zich verwonden aan de verpakking. |
| PL | Produkt nie służy do zabawy! Dzieci nie powinny bawić się opakowaniem produktu, gdyż mogą się udusić folią lub skaleczyć opakowaniem. |
| TR | Bu ürün bir çocuk oyuncakı değildir! Çocukların ürün ambalajlarıyla oynamalarına asla müsaade etmeyiniz. Çocuklar, folyo nedeniyle boğulabilir veya ambalaj nedeniyle yaralanabilirler. |
| RU | Не допускается игра детей с изделием! Не разрешайте детям играть с упаковочным материалом. Дети могут задохнуться в упаковочной пленке или пораниться упаковочным материалом. |

Service • Dienstverlening • Serwis • Servis • Сервисная служба

Name • Naam • Nazwa • Isim • Название

LYRA

Nr. • No. • Номер

22 LY

Typ • Type • Тип • Тип

22R

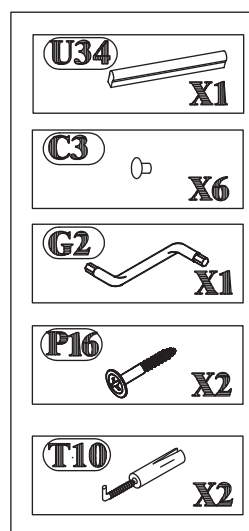
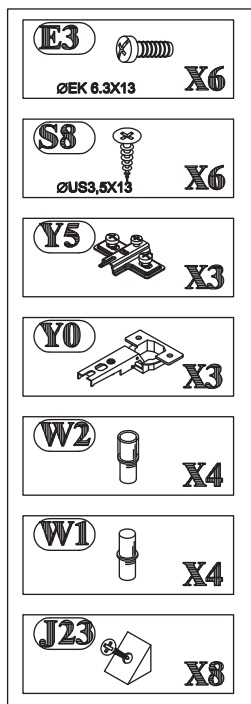
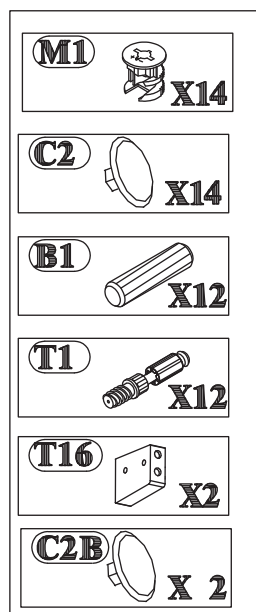
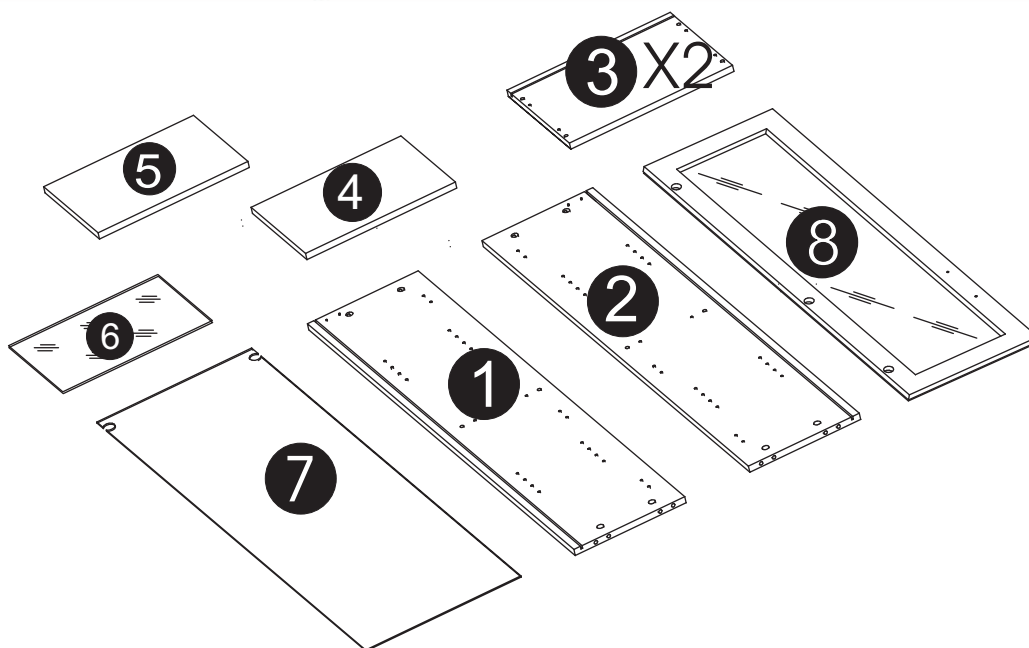
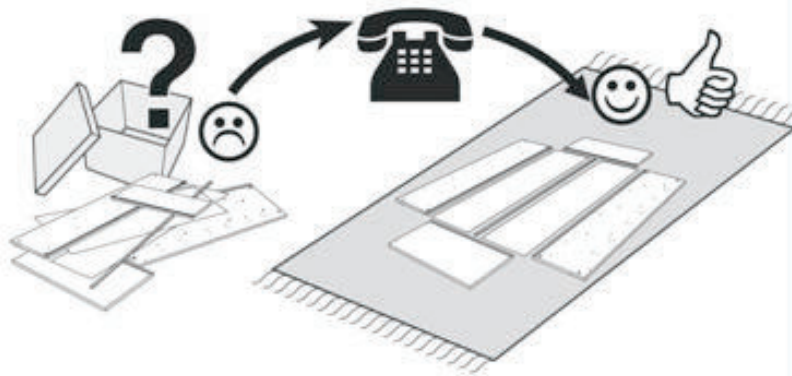

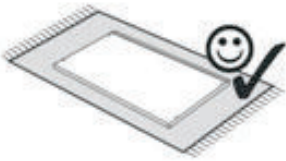

1

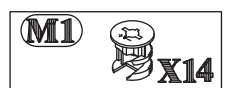
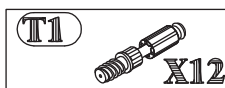
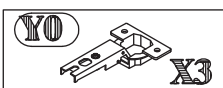
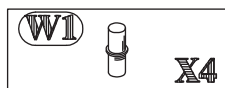
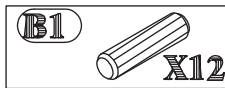
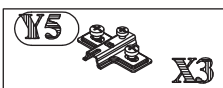
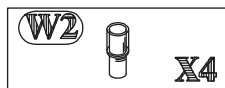
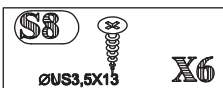
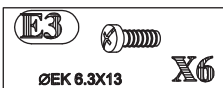
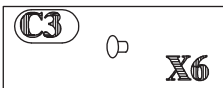
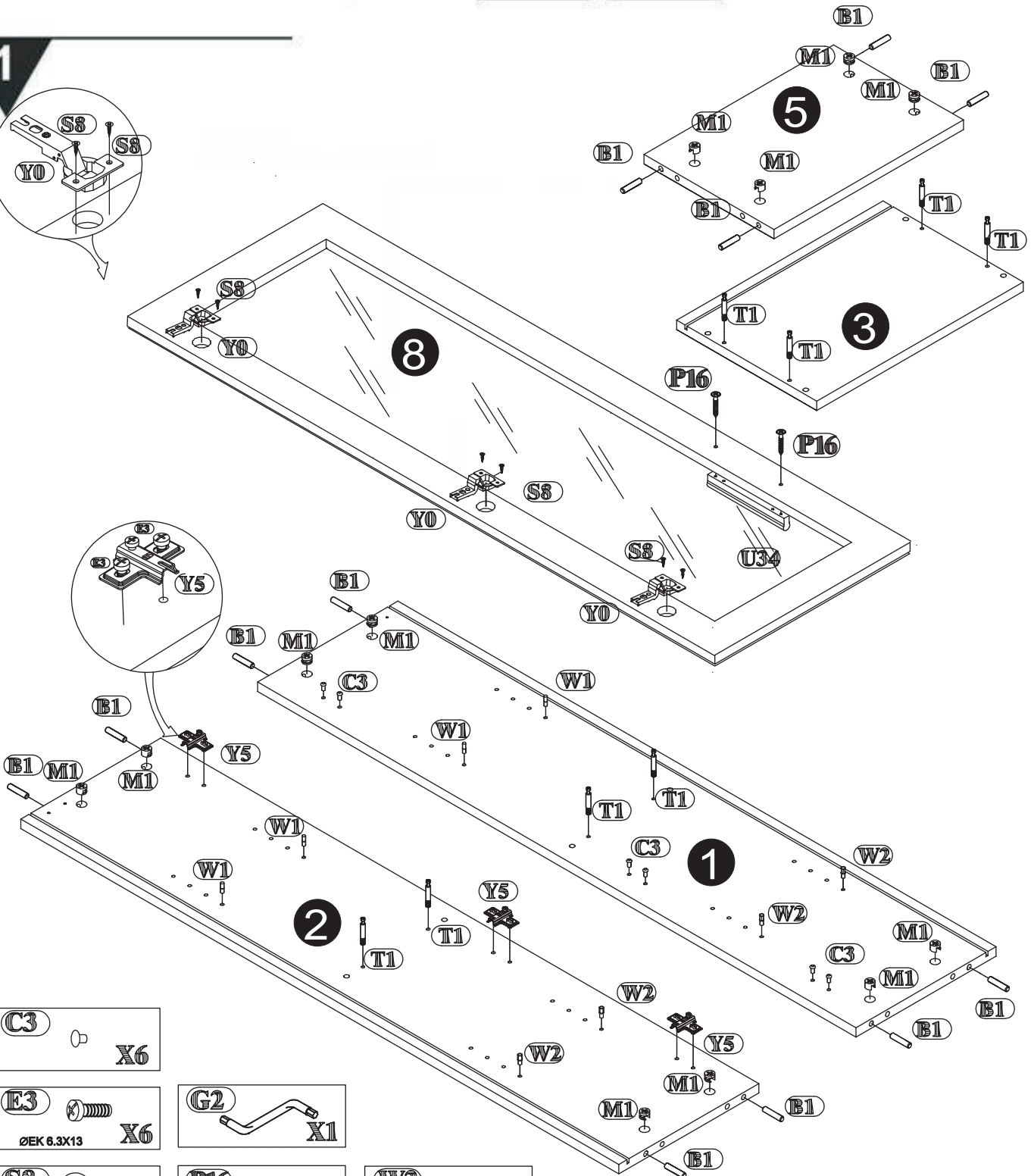
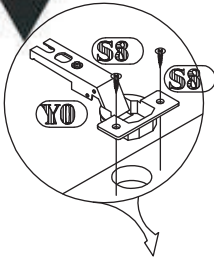

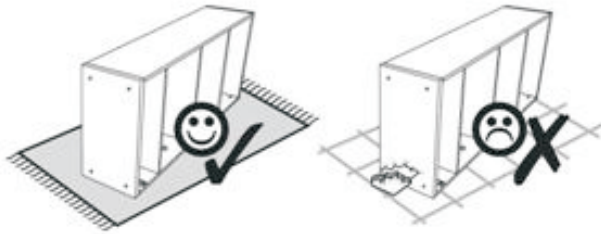

2

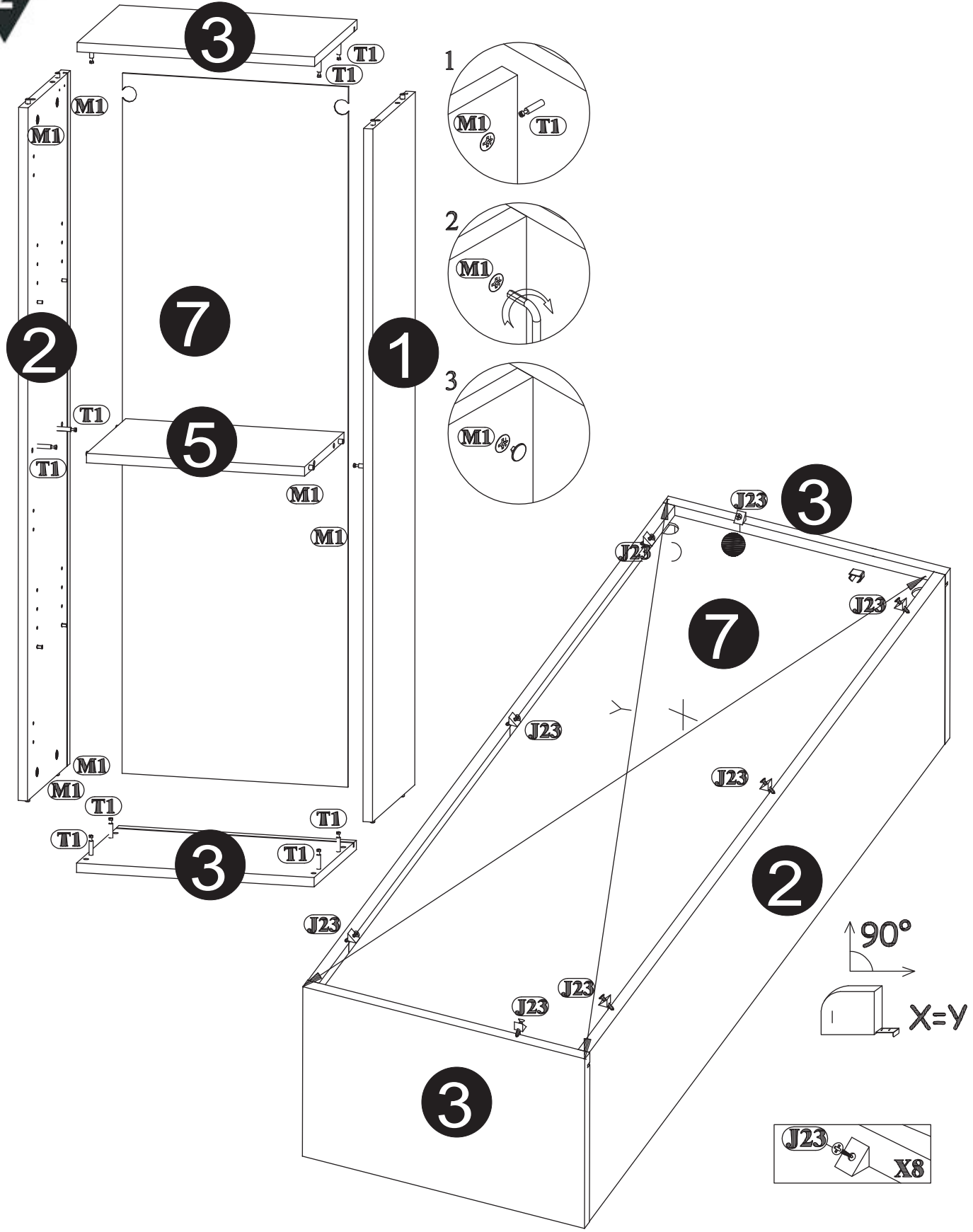



3

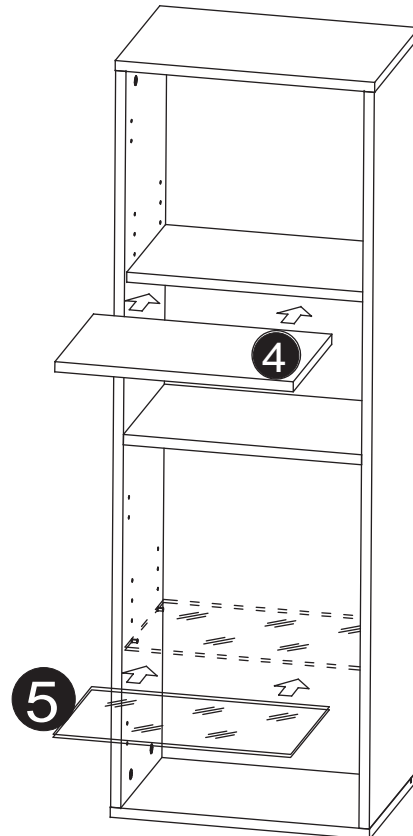
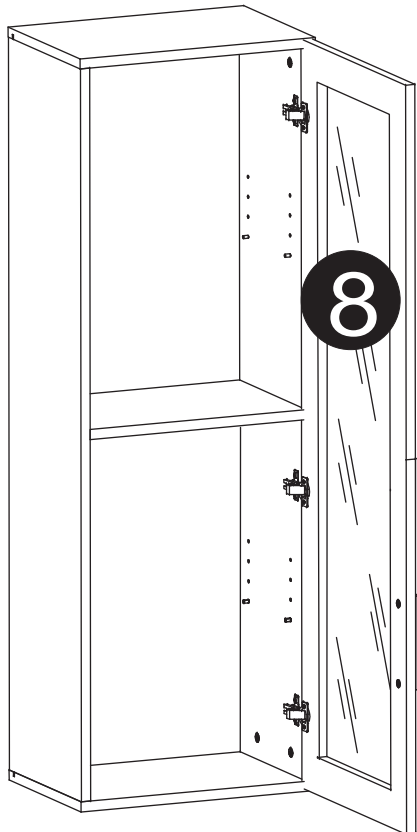
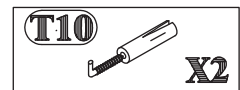
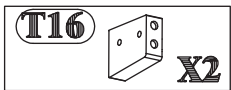
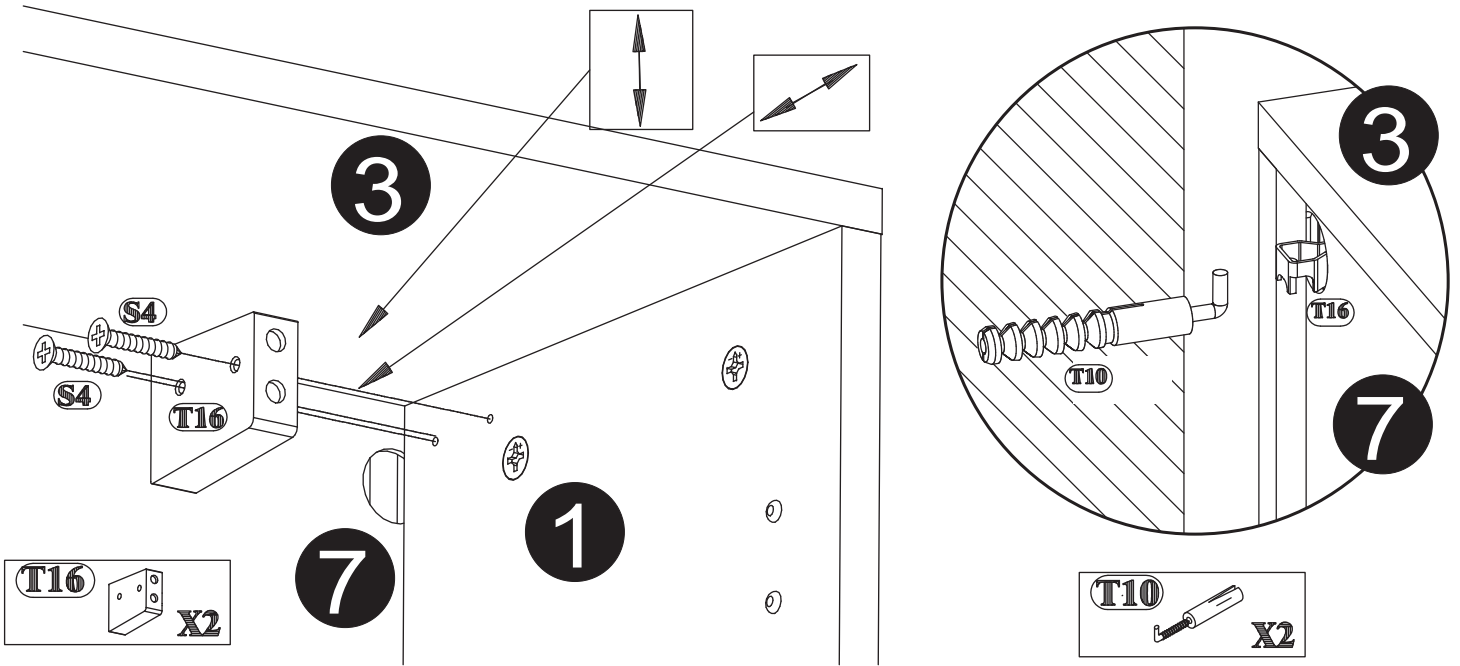

Türen einstellen (Scharniere justieren)

Adjusting the doors (adjusting the hinges)

Deuren instellen (scharnieren afstellen)

Nastawić drzwi (wyrównać zawiasy)

Kapıların ayarlanması (mentşelerin seviye ayarı)

Регулировка дверей (регулировка шарнира)

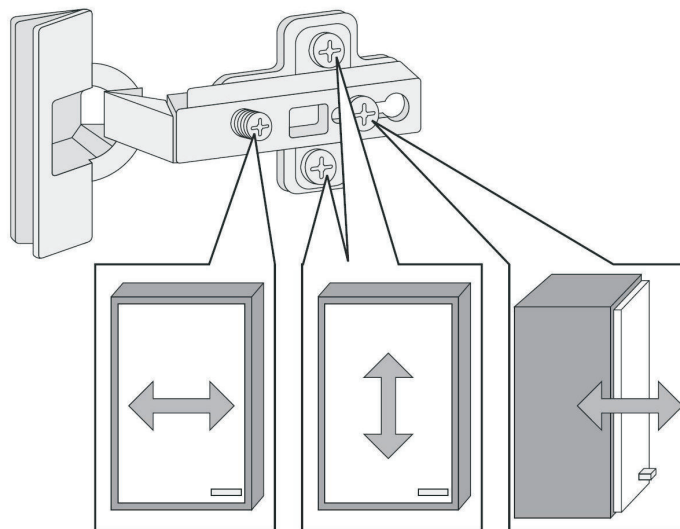

ABW LYRA TYP 30

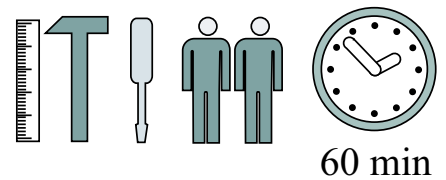
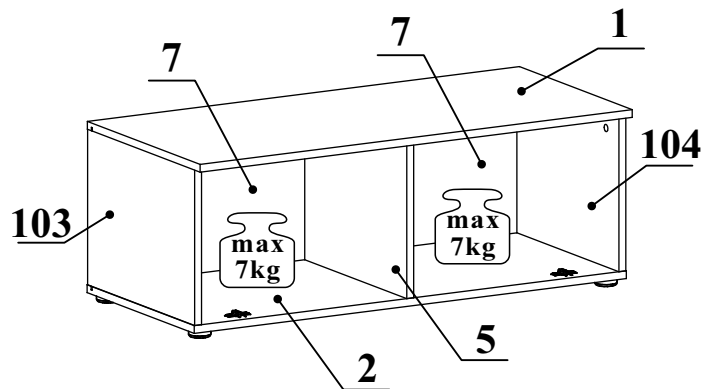
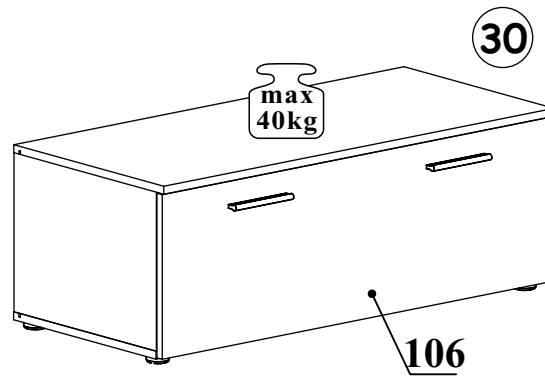
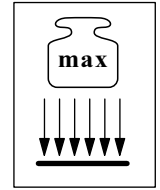
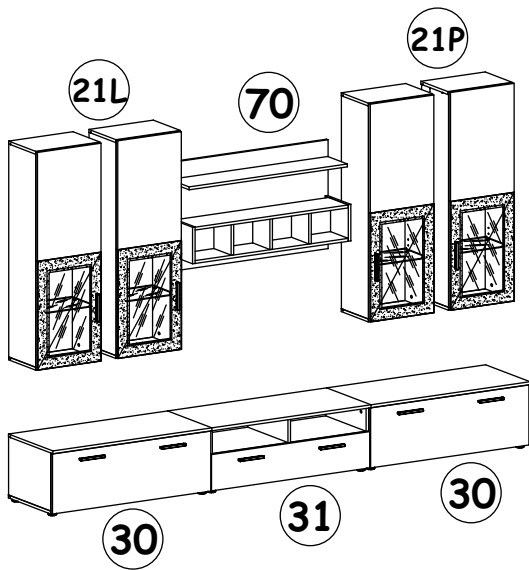

60 min

| NO | Dim. | | Col.-No | Qty |
|-----|------|-----|---------|-----|
| 103 | 320 | 430 | 1 | 1 |
| 104 | 320 | 430 | 1 | 1 |
| 5 | 320 | 410 | 1 | 1 |
| 2 | 1001 | 430 | 1 | 1 |
| 1 | 1001 | 453 | 1 | 1 |
| 7 | 489 | 332 | 1 | 2 |
| 106 | 996 | 331 | 1 | 1 |

ABW LYRA TYP 30

| | | | | | |
|------------------------|-----------------|---------------------|------------------------|---------------------|------------------------|
| A1 X12 ø8x36 | B4 X12 | B5 X12 ø15x12 | G5 X12 | I11 X5 | D11 X5 USØ3,5x25 |
| E1 X2 Ø26 H=0 | E2 X2 H=0 | S1 X6 | D10 X8 USØ3,5x13 | KL X2 L-128mm | UP6 X4 UPØ4x30 |
| G2 X1 | G16 X3 | D9 X3 USØ3x20 | D7 X6 USØ3x16 | G21 X2 | |

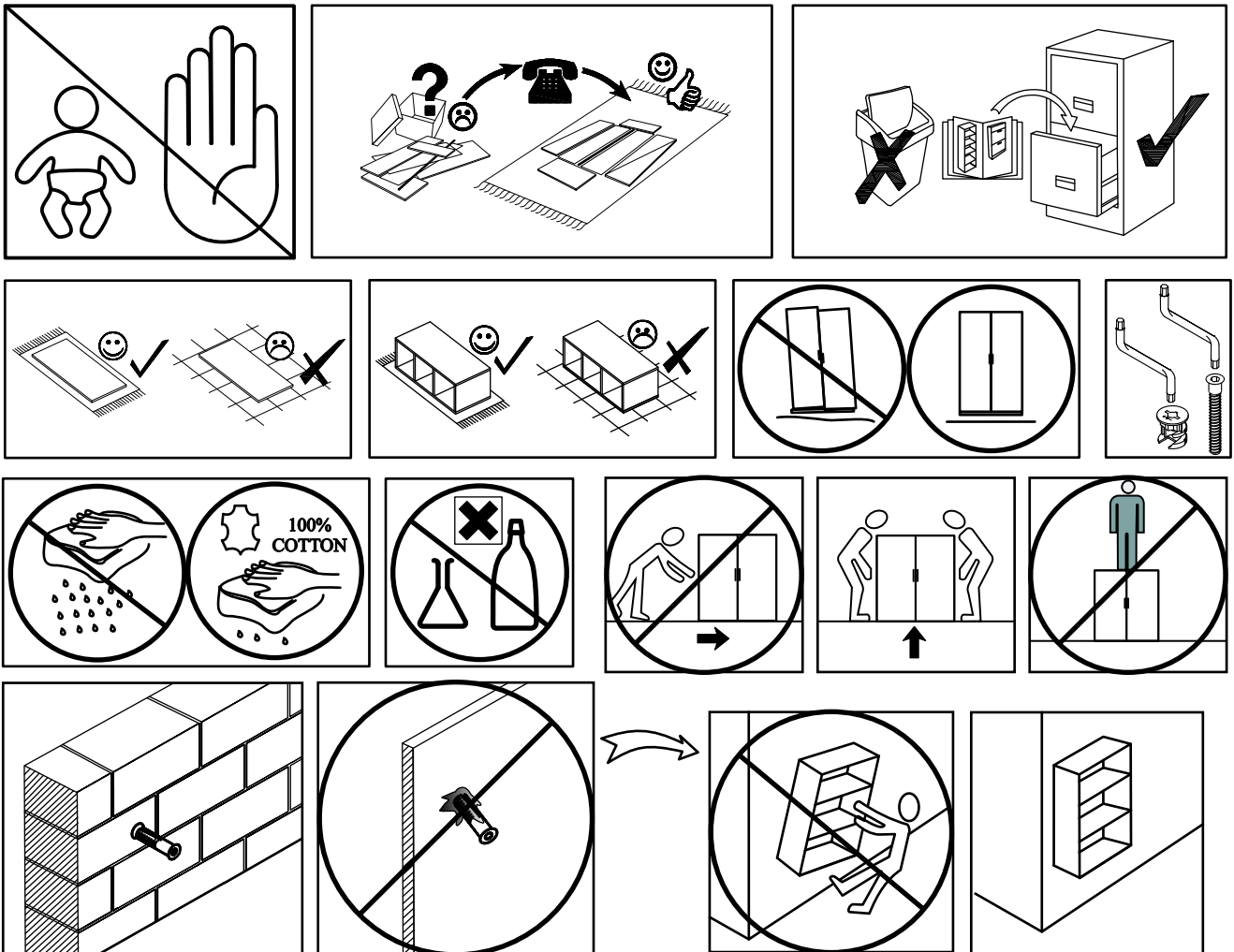
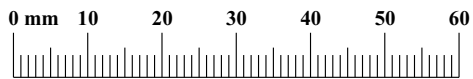

1

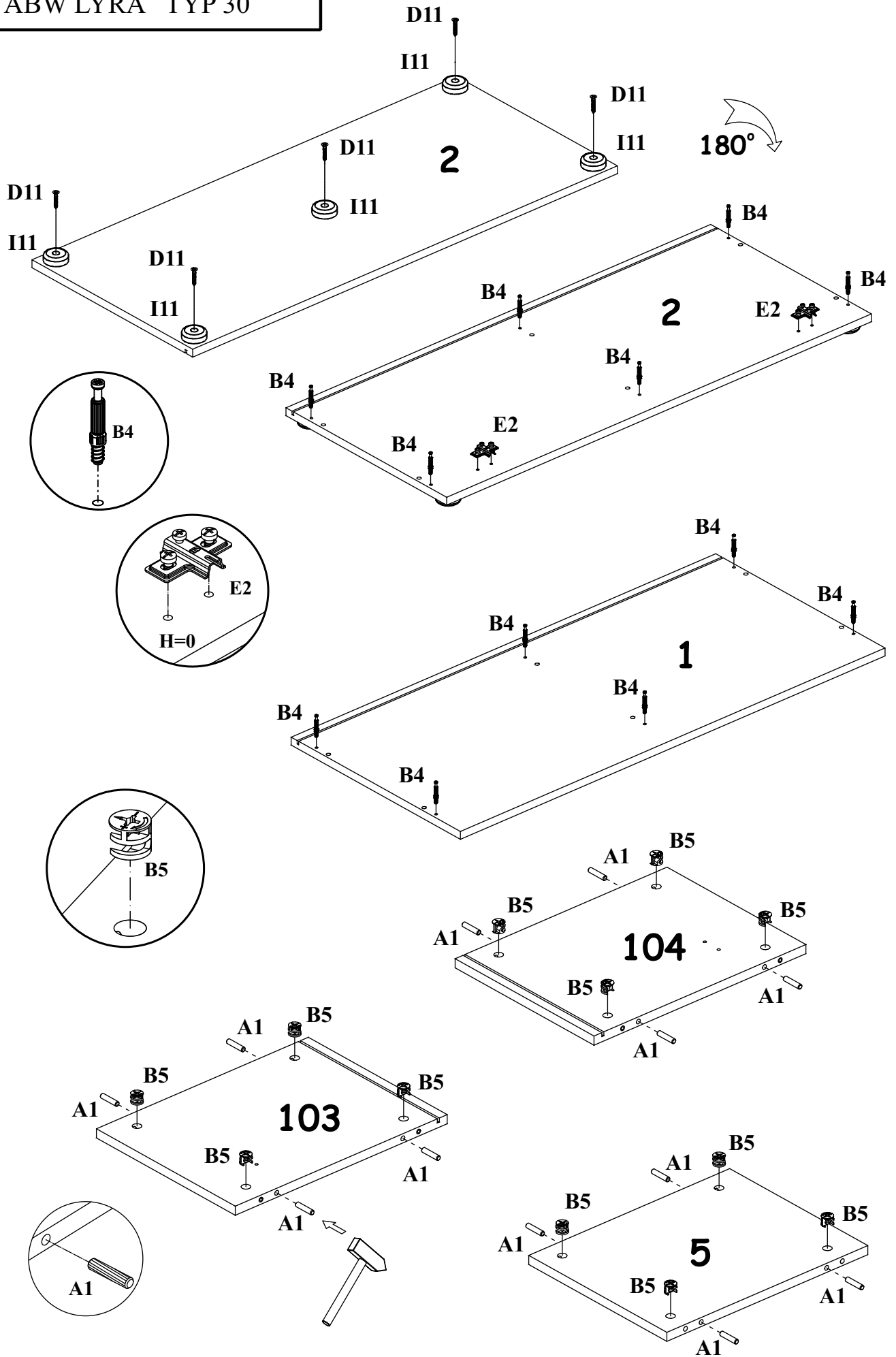

2

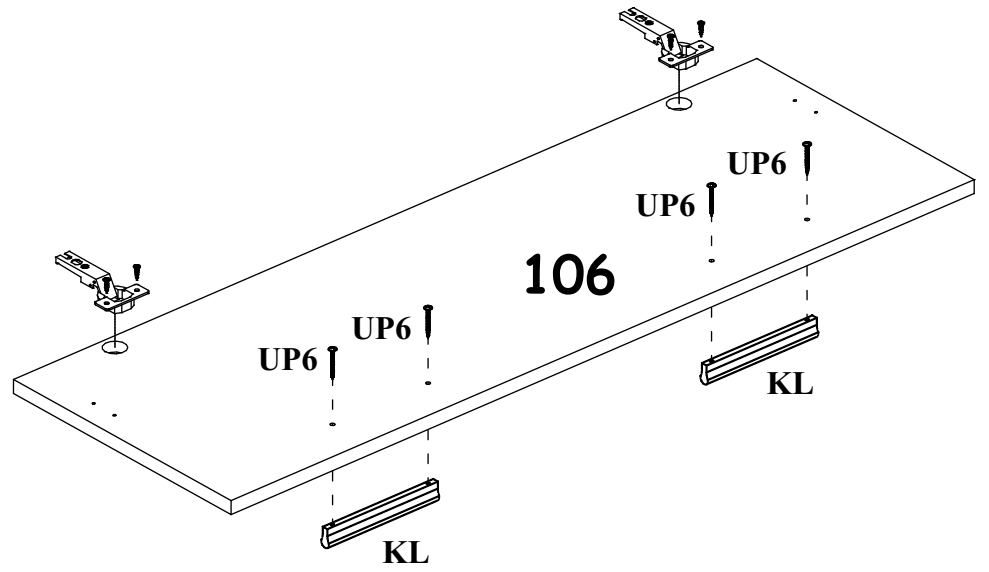
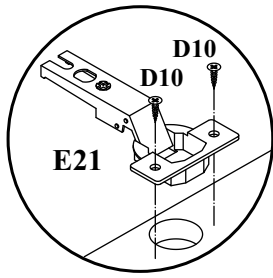

3

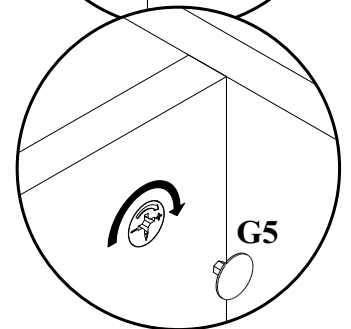
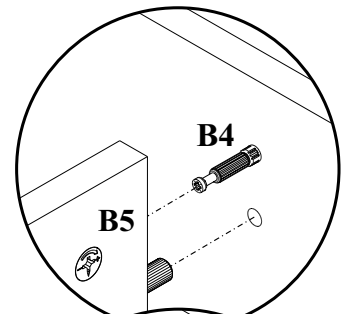
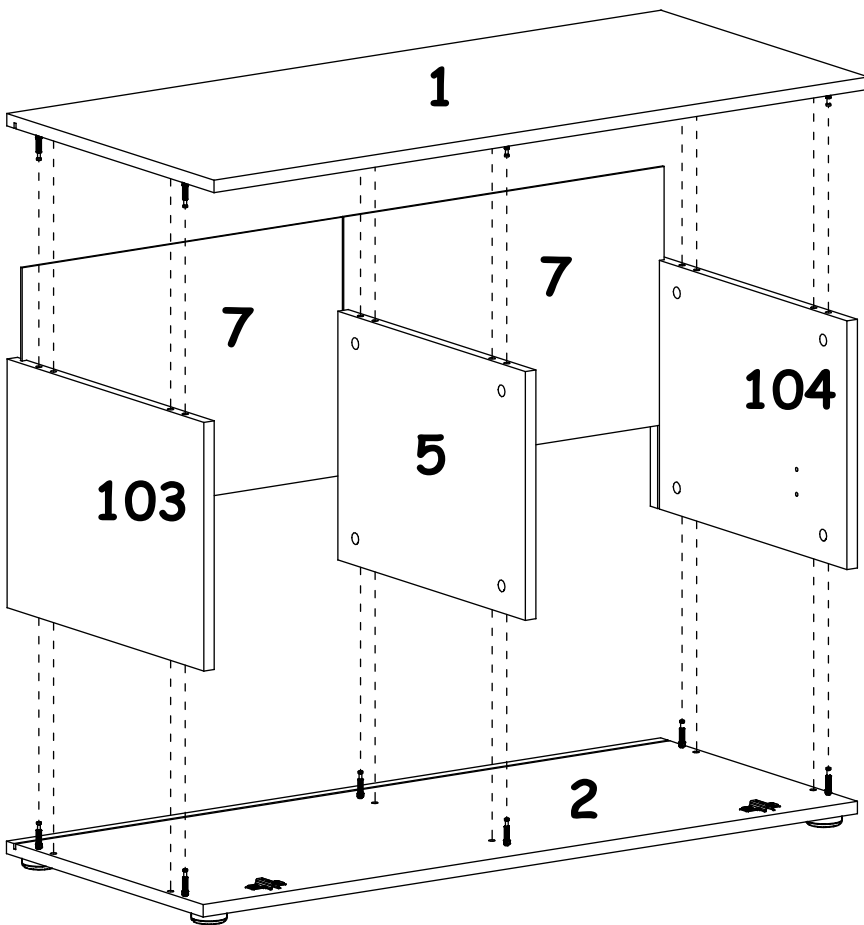

4

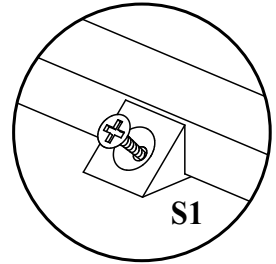
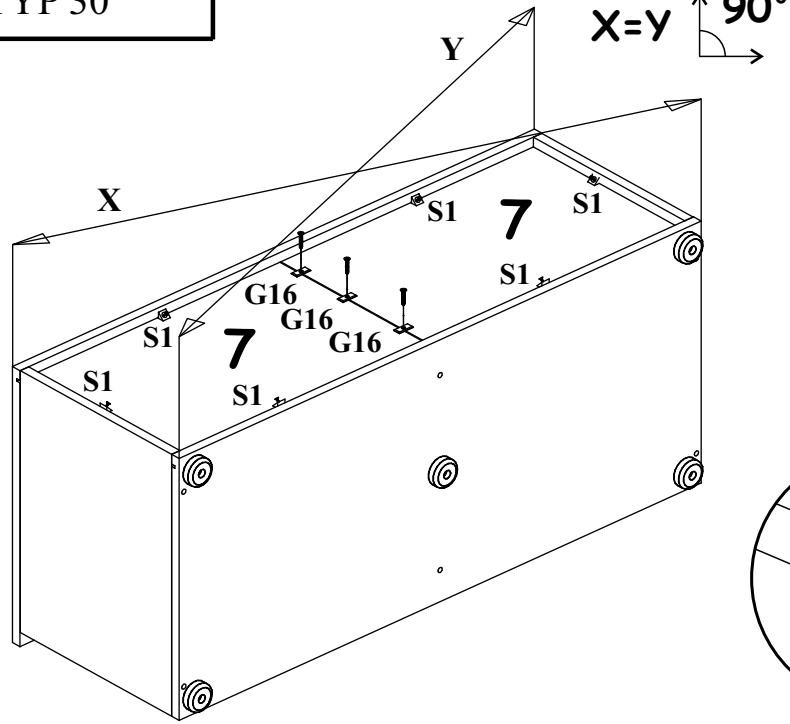
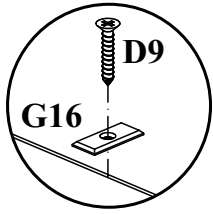

5

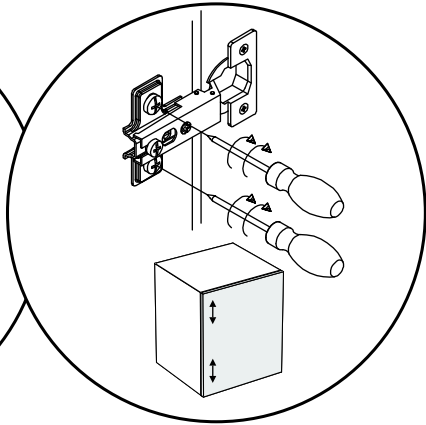
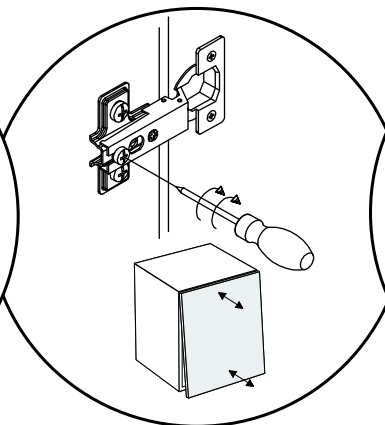
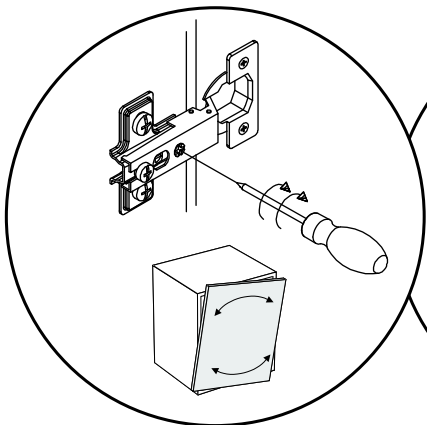
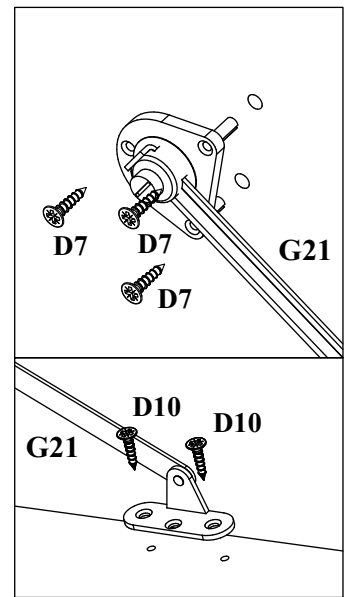
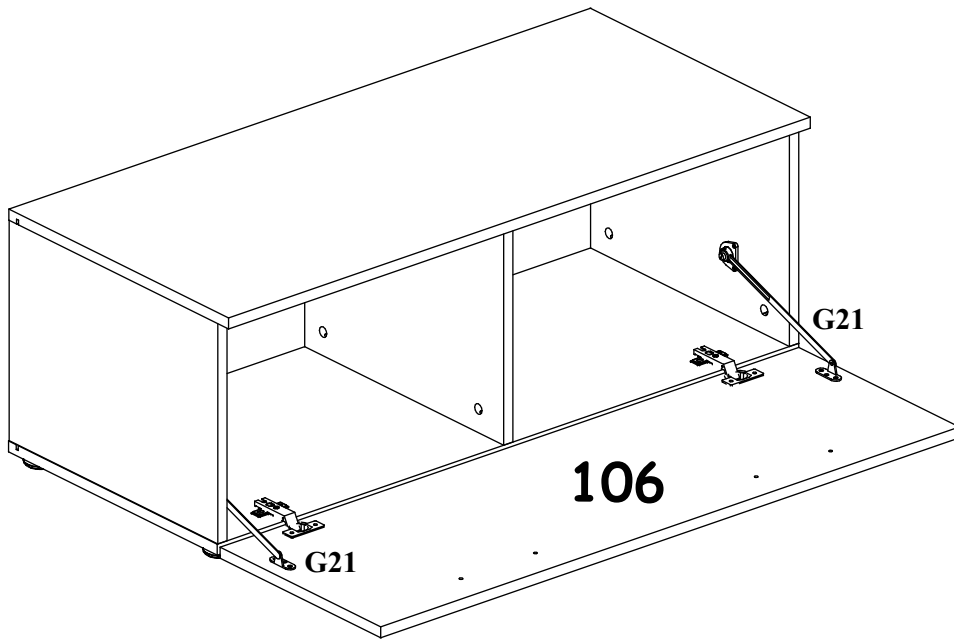

ABW LYRA TYP 31

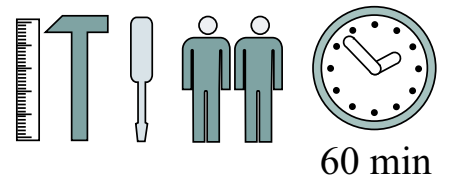
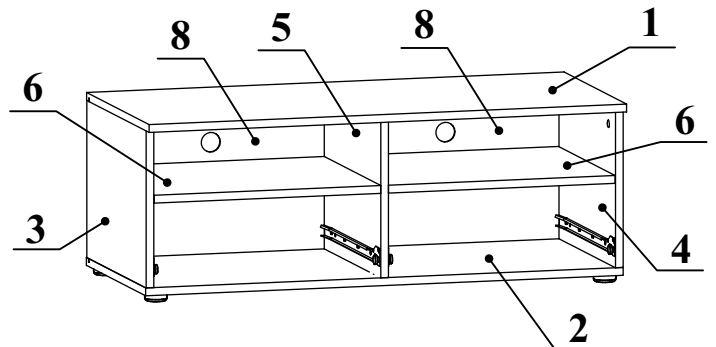
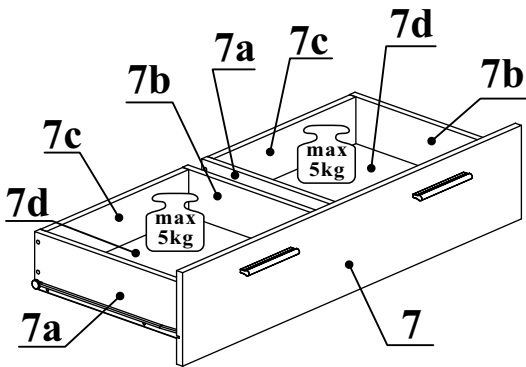
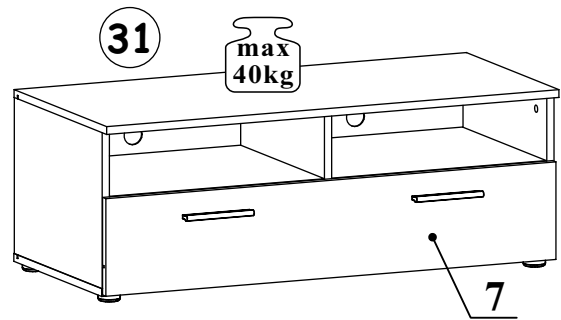
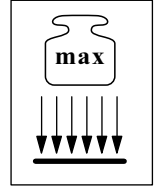
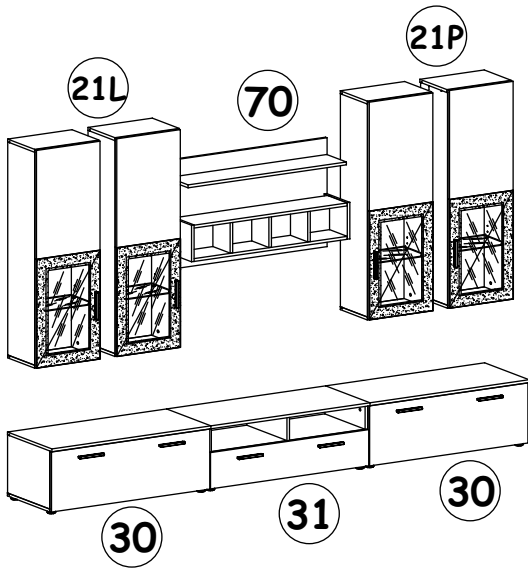

| NO | Dim. | | Col.-No | Qty |
|----|------|-----|---------|-----|
| 3 | 320 | 430 | 1 | 1 |
| 4 | 320 | 430 | 1 | 1 |
| 5 | 320 | 410 | 1 | 1 |
| 6 | 475 | 410 | 1 | 2 |
| 2 | 1001 | 430 | 1 | 1 |
| 1 | 1001 | 453 | 1 | 1 |
| 8 | 489 | 332 | 1 | 2 |
| 7 | 996 | 200 | 1 | 1 |
| 7a | 400 | 120 | 1 | 2 |
| 7b | 400 | 120 | 1 | 2 |
| 7c | 418 | 100 | 1 | 2 |
| 7d | 431 | 403 | 1 | 2 |

ABW LYRA TYP 31

| | | | | | |
|-----------------------|---------------------|---------------------|-------------------------|---------------------|------------------------|
| A1 X28 ø8x36 | B4 X10 | B5 X14 ø15x12 | G5 X14 | I11 X5 | G2 X1 |
| B11 X14 ø7x50 | G4 X14 | S1 X6 | D10 X12 USØ3,5x13 | H5 X2 L-400mm | D11 X5 USØ3,5x25 |
| G1 X2 | G16 X3 | B6 X2 ø7x78 | D27 X12 ESØ6x8 | KL X2 L-128mm | UP6 X4 UPØ4x30 |
| UP13 X8 UPØ3x16 | D9 X3 USØ3x20 | G17 X2 ø40 | | | |

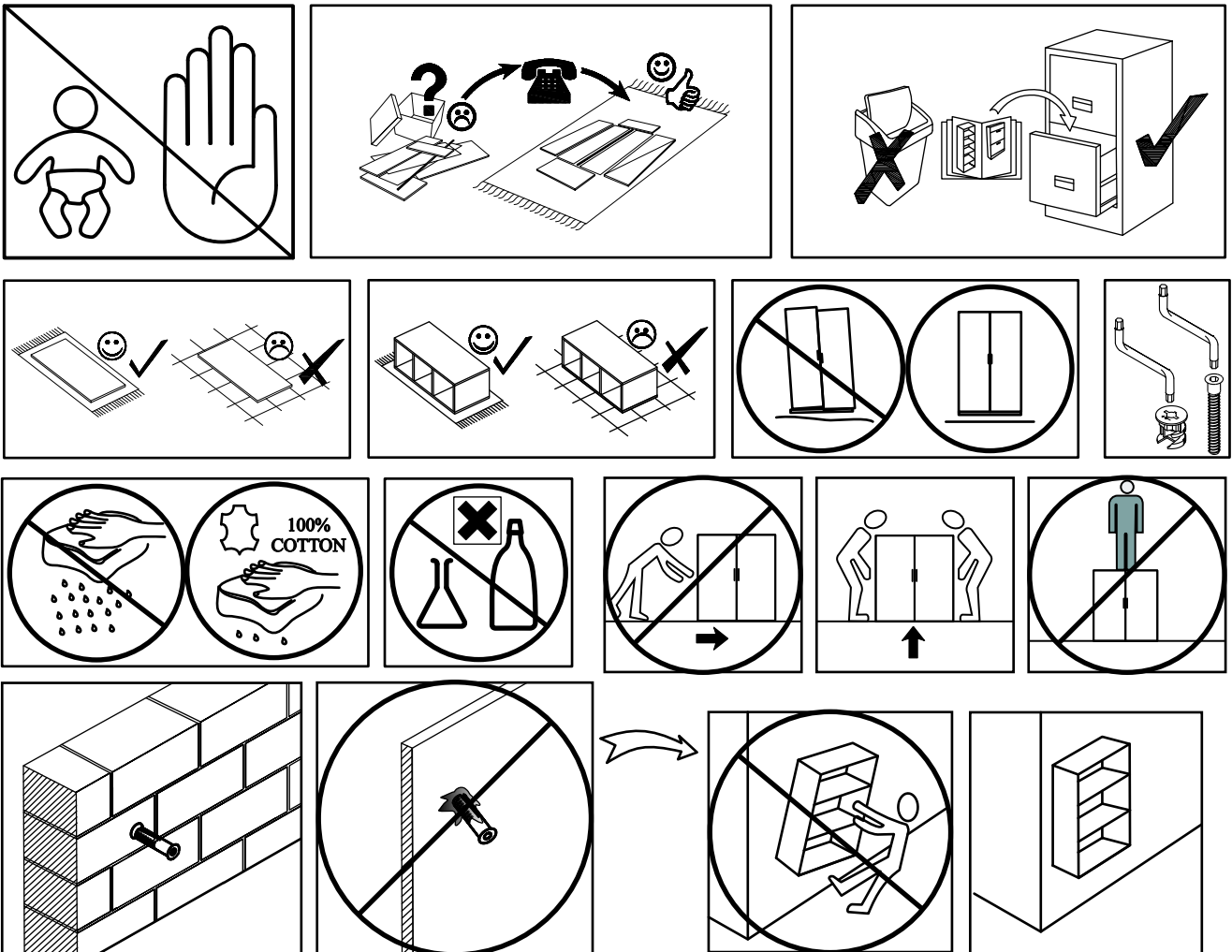
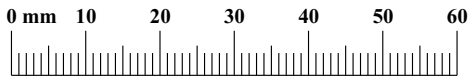

1

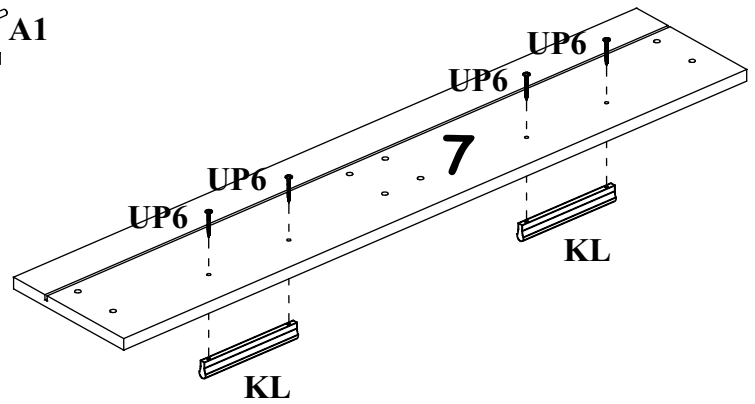
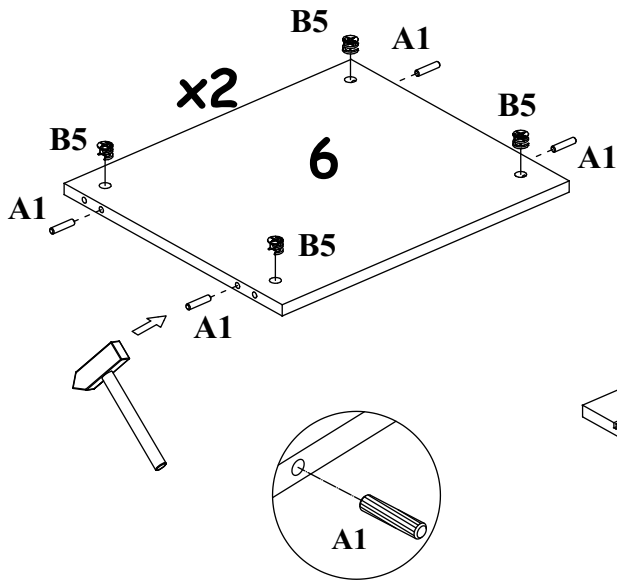
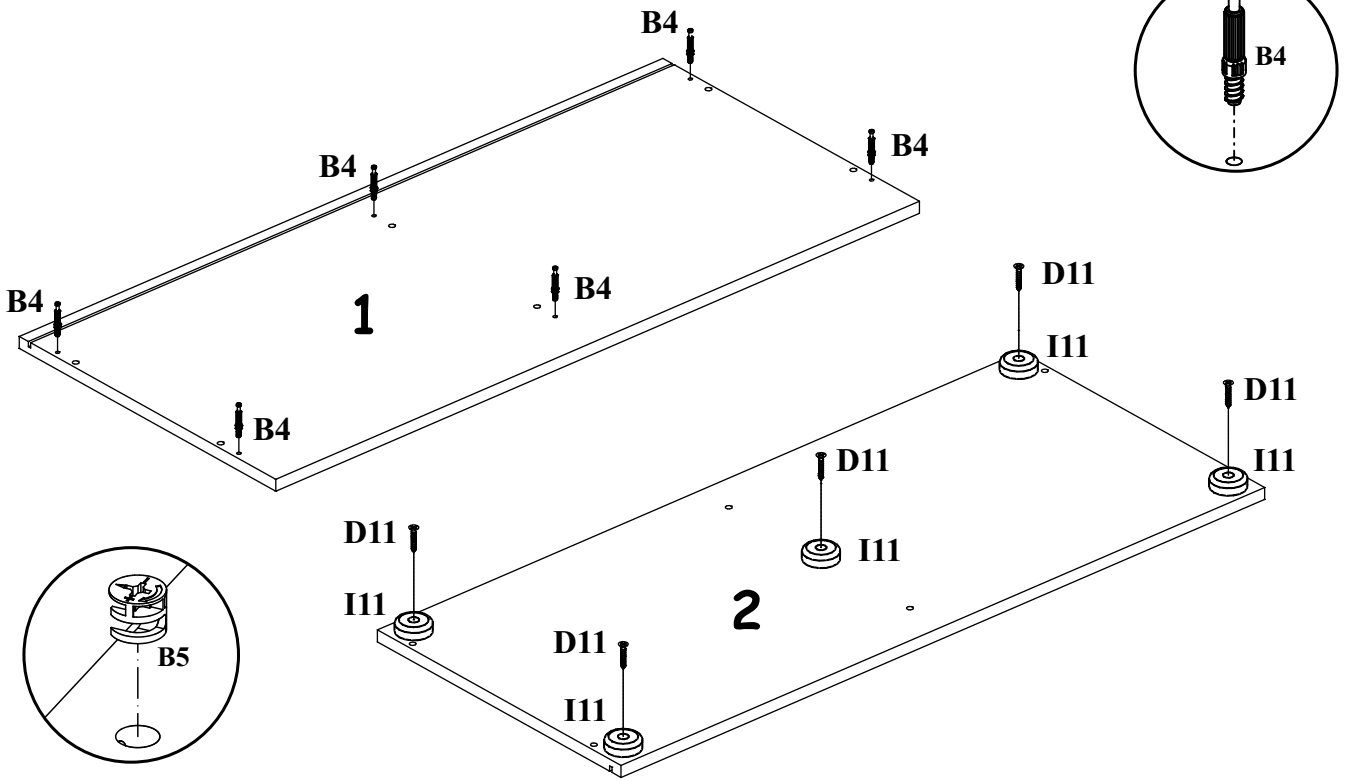

2

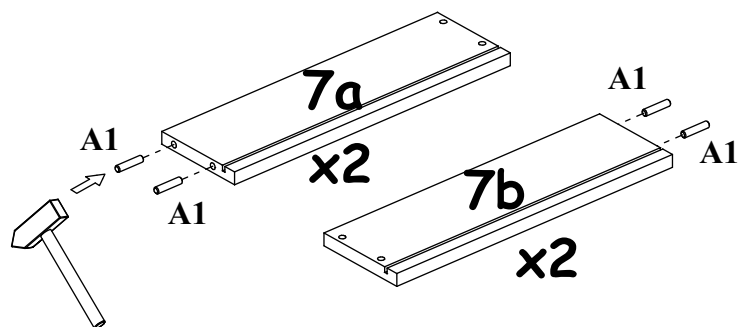
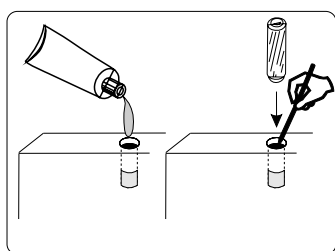

3

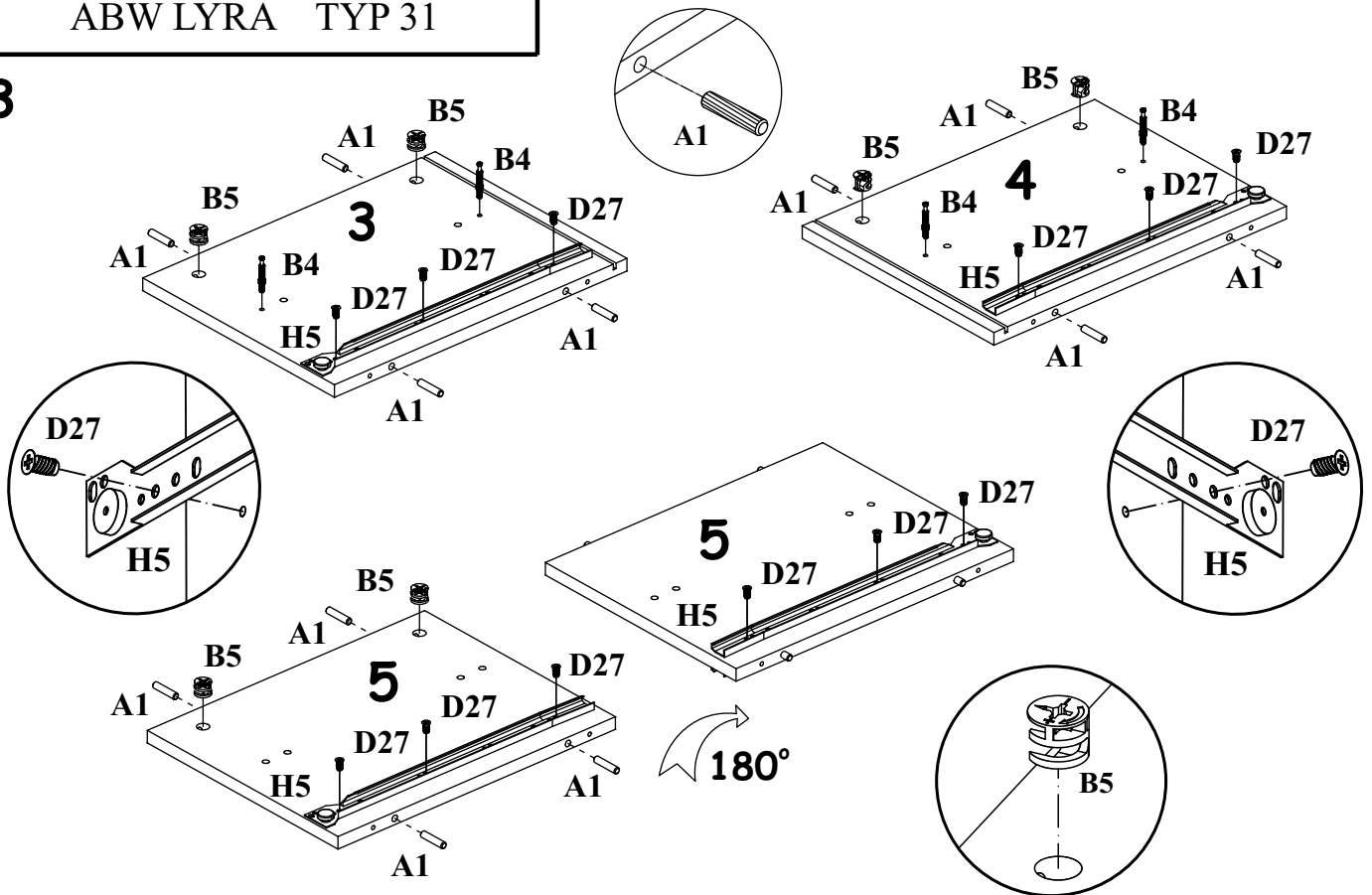

4

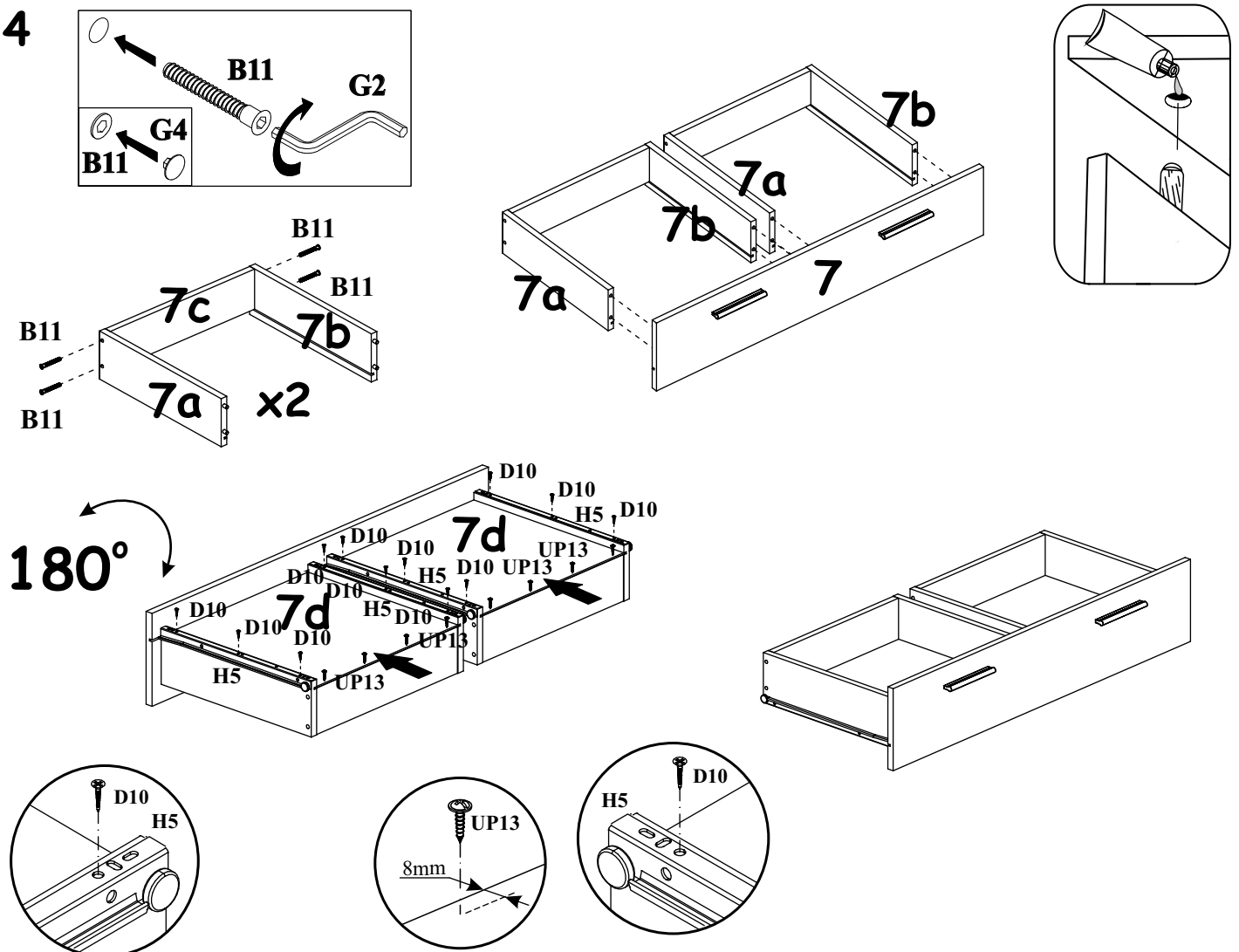

ABW LYRA TYP 31

5

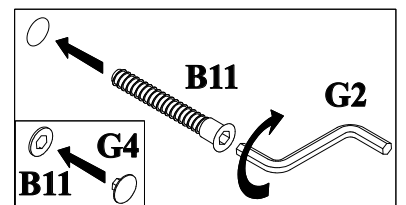
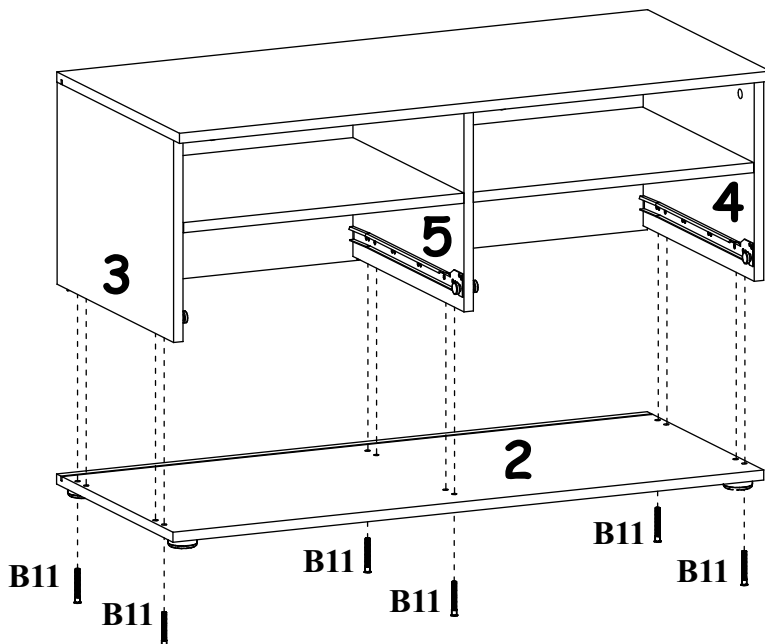
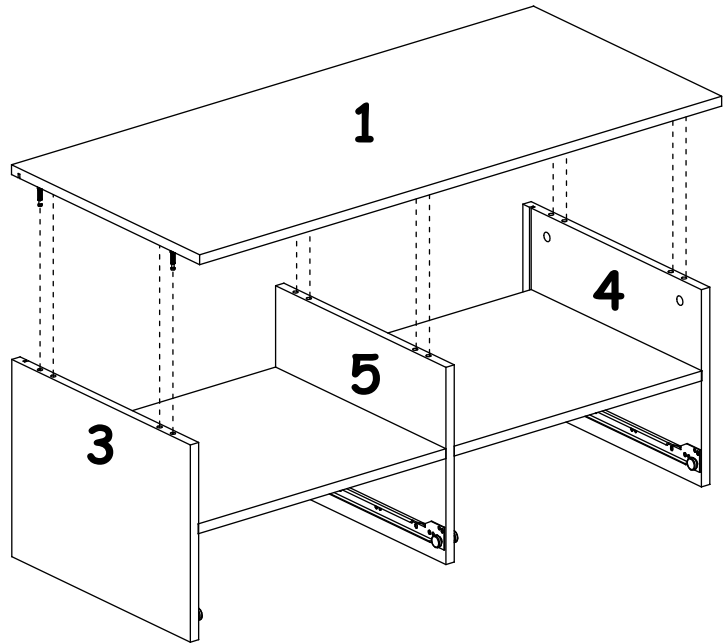
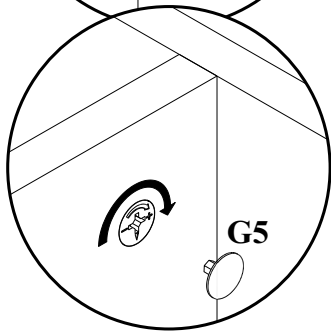
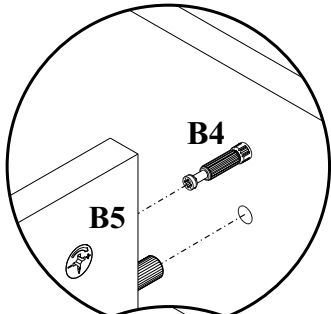
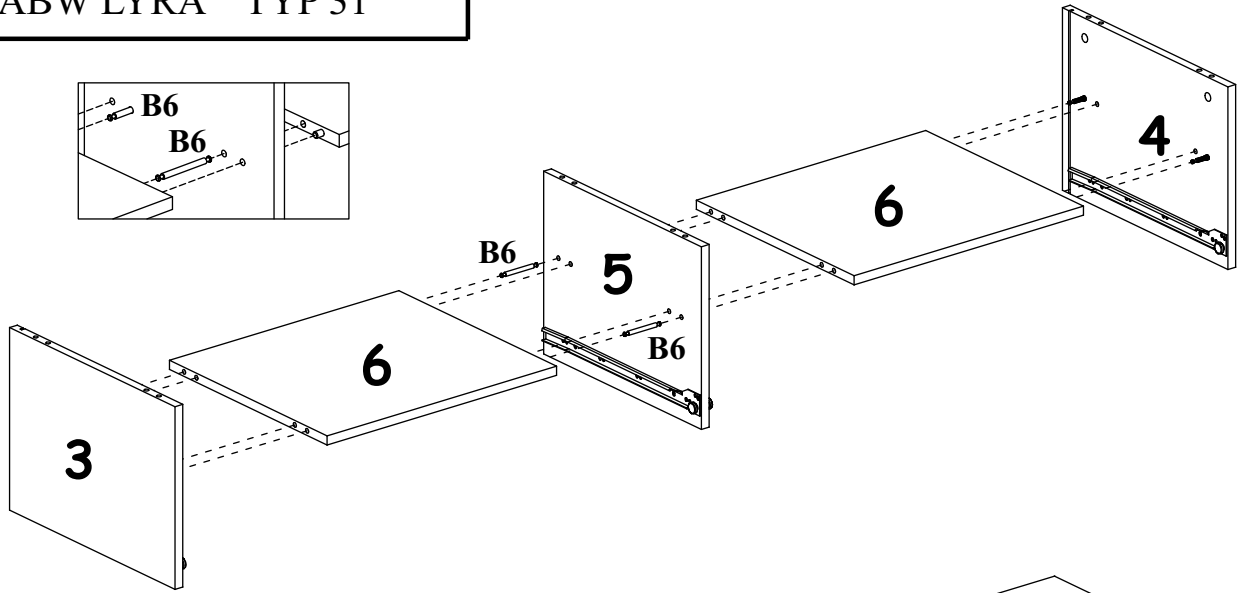

6

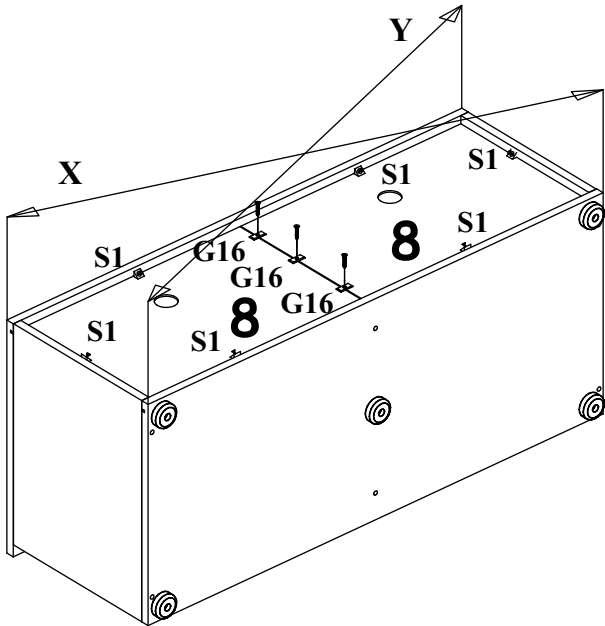
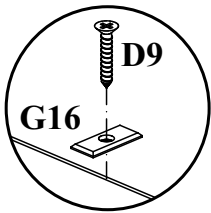

X=Y 90°

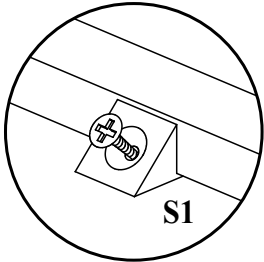

7

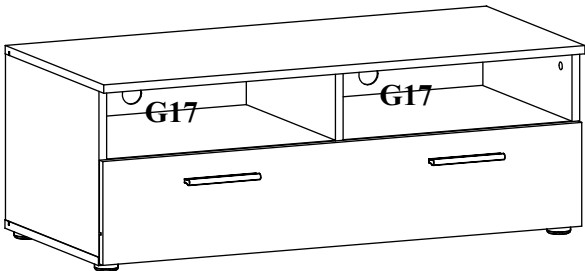
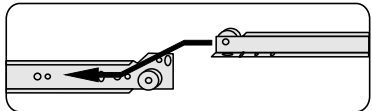
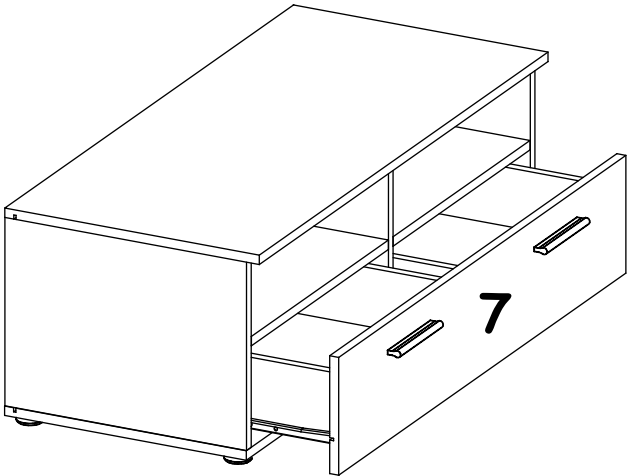

ABW LYRA TYP 70

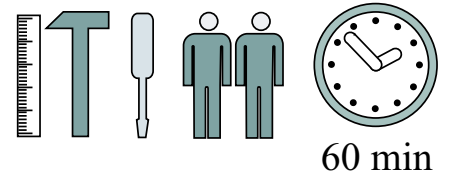
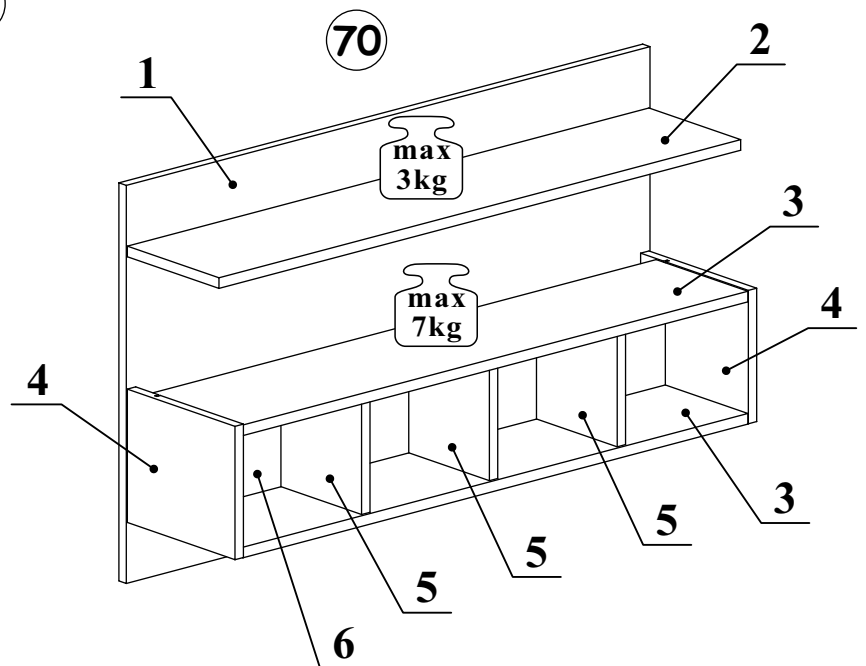
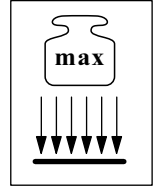
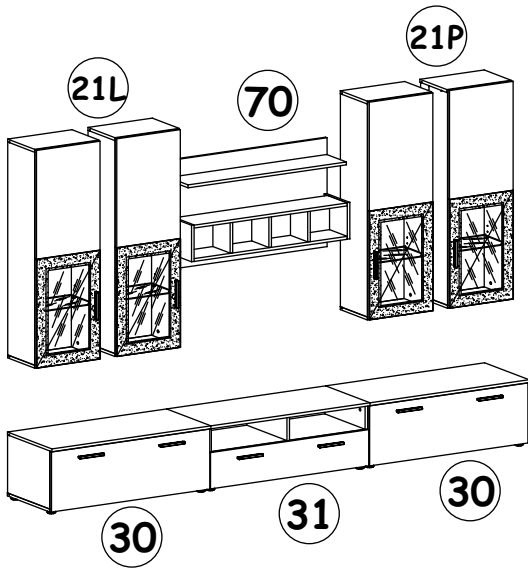

| NO | Dim. | | Col.-No | Qty |
|----|------|-----|---------|-----|
| 1 | 1000 | 600 | 1 | 1 |
| 3 | 964 | 200 | 1 | 2 |
| 2 | 996 | 200 | 1 | 1 |
| 4 | 201 | 235 | 1 | 2 |
| 5 | 168 | 176 | 1 | 3 |
| 6 | 976 | 180 | 1 | 1 |

ABW LYRA TYP 70

| | | | | | |
|--------------------|---------------------|-----------|-----------------------|--------------------|----------|
| A1 X26 Ø8x36 | KR2 X2 | ZM1 X2 | D20 X4 ESØ6x9,5 | B11 X8 Ø7x50 | T5 X1 |
| G1 X2 | B3 X6 Ø1,4x25 | G2 X1 | | | |

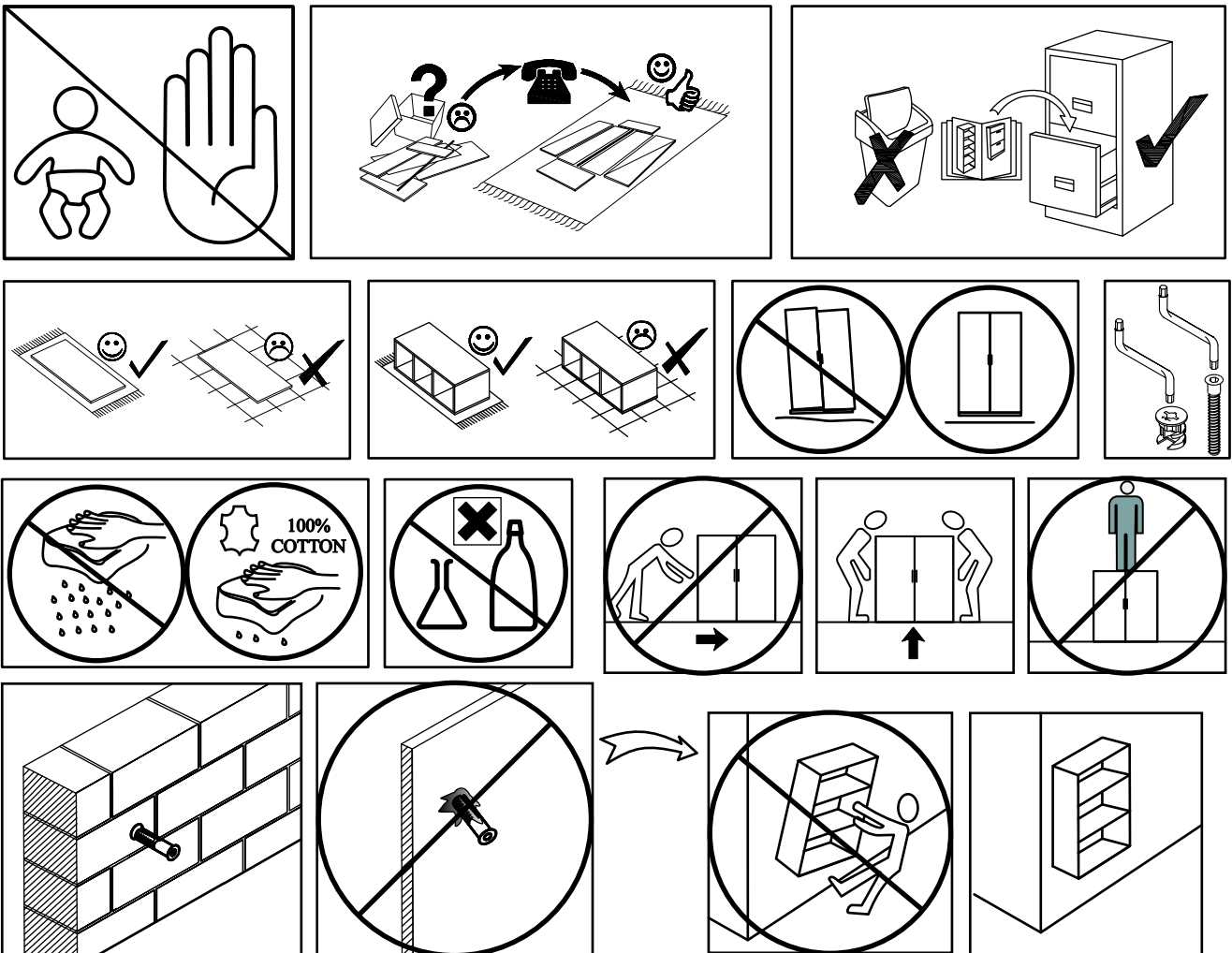
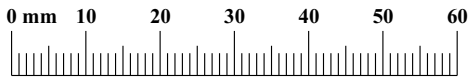

1

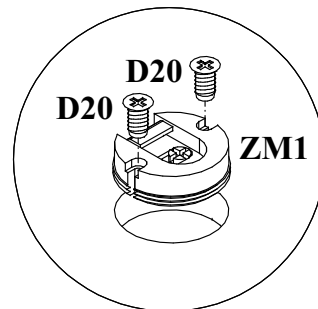
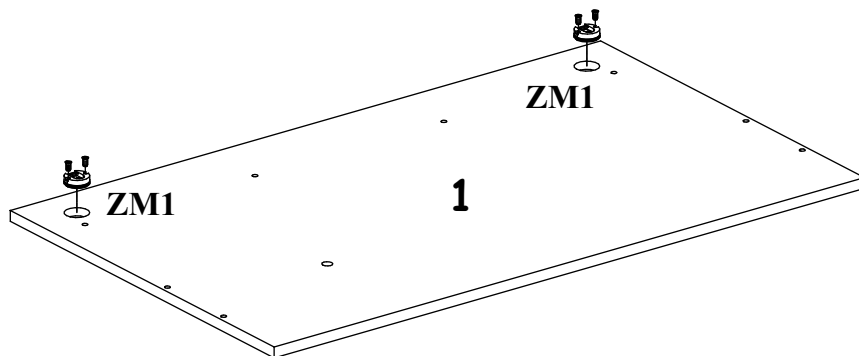

2

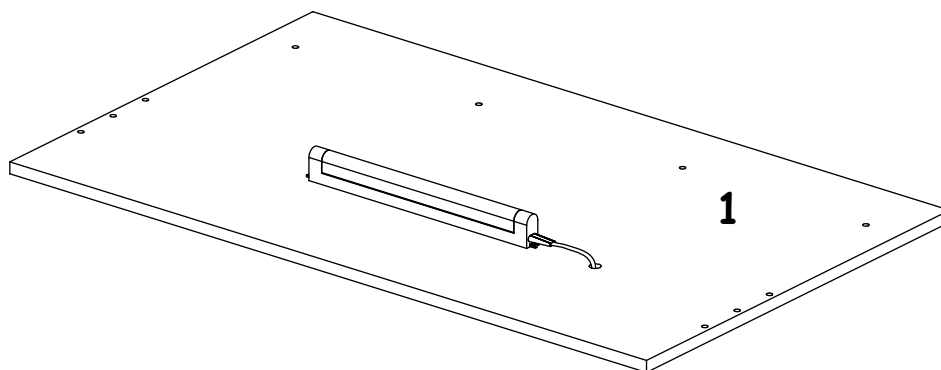
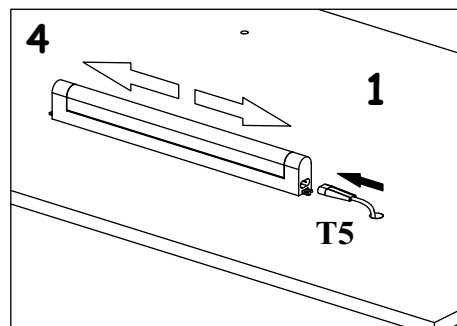
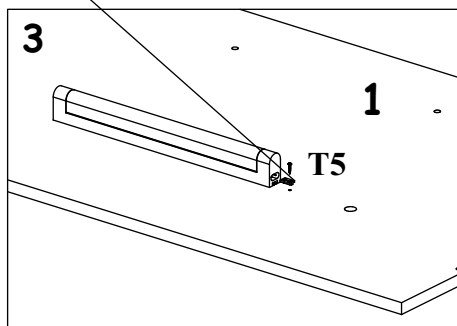
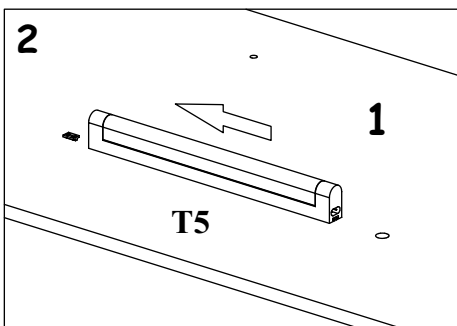
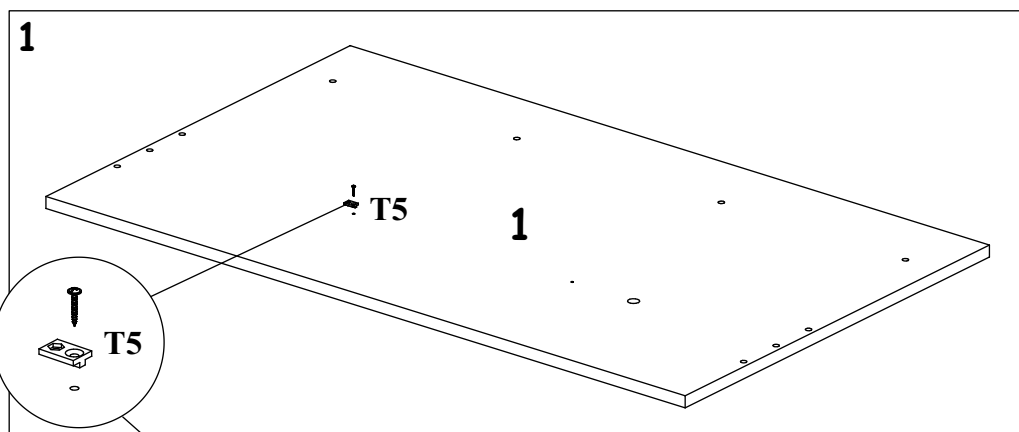

3

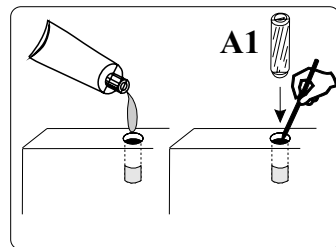
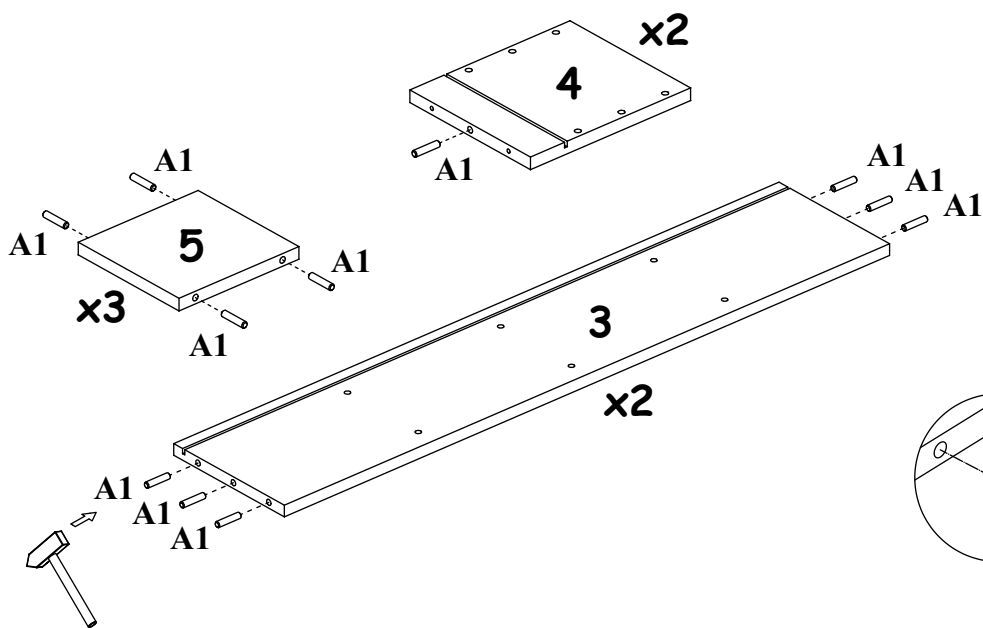

4

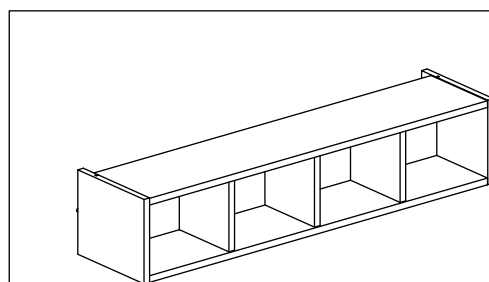
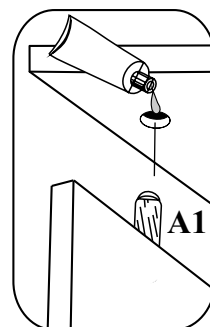
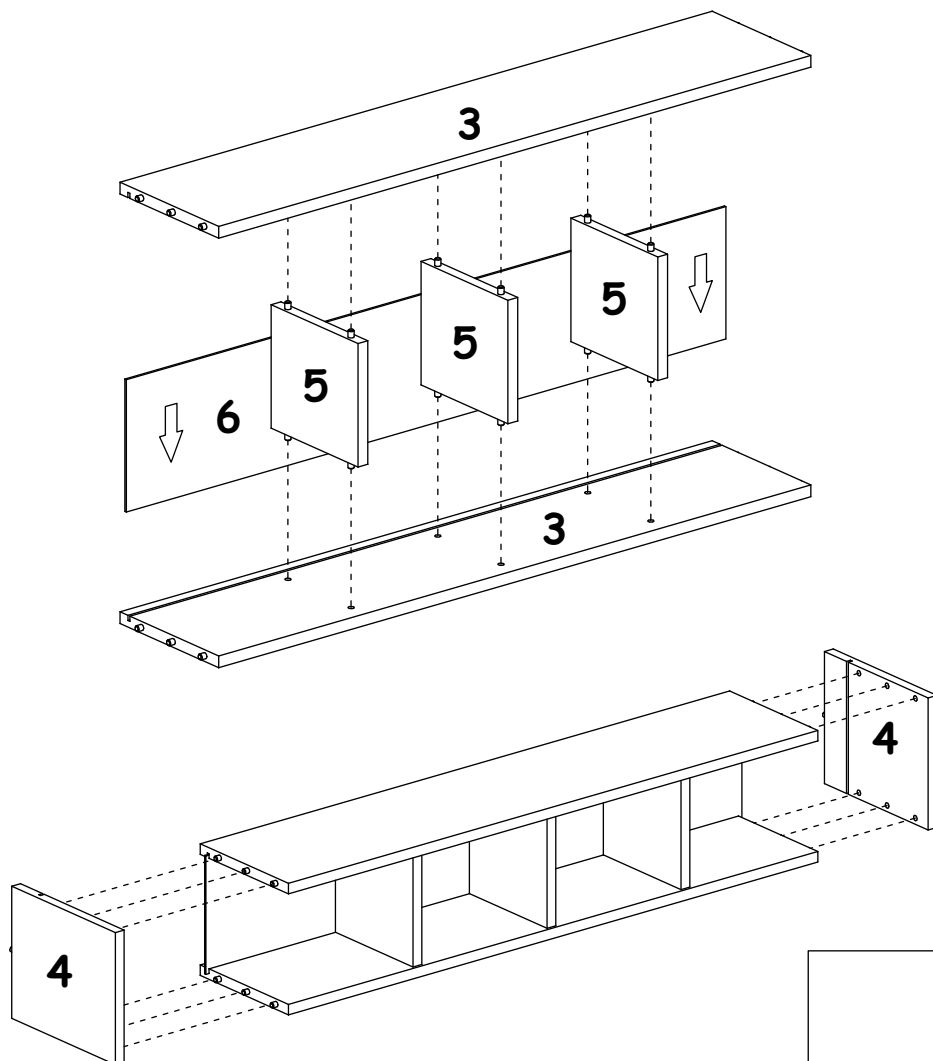

5

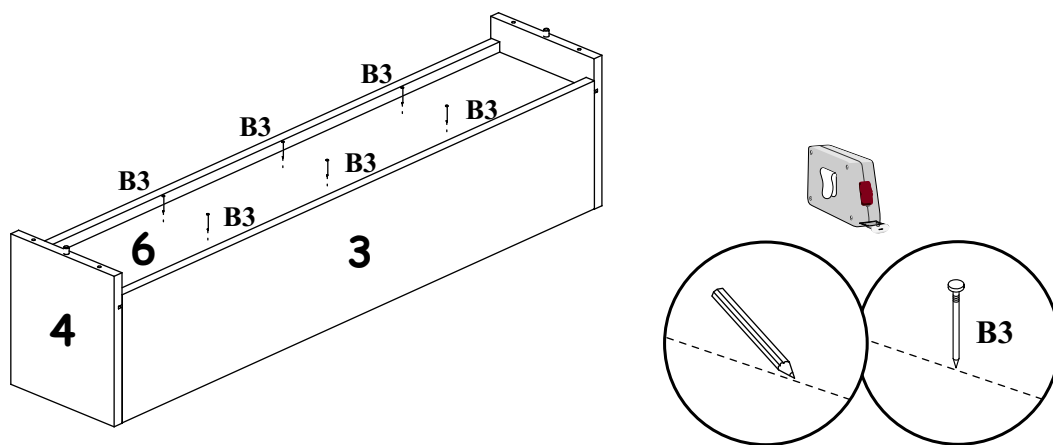

6

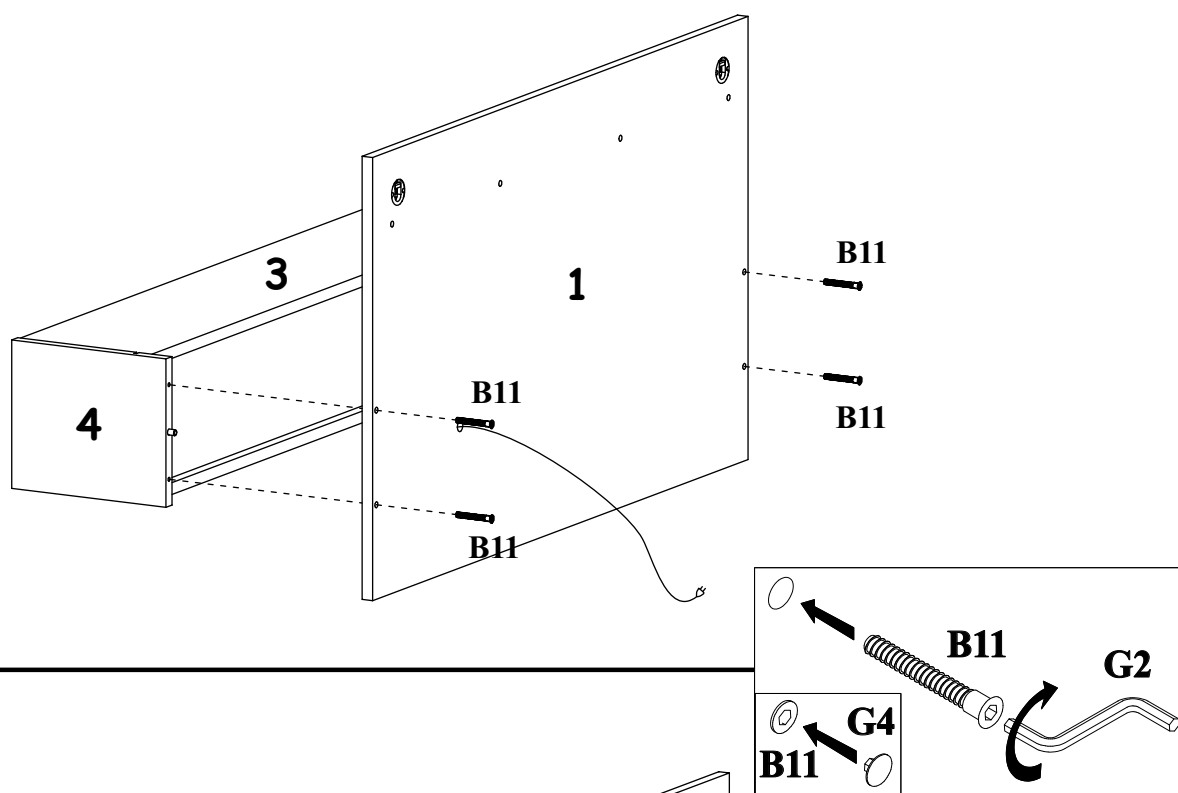

6

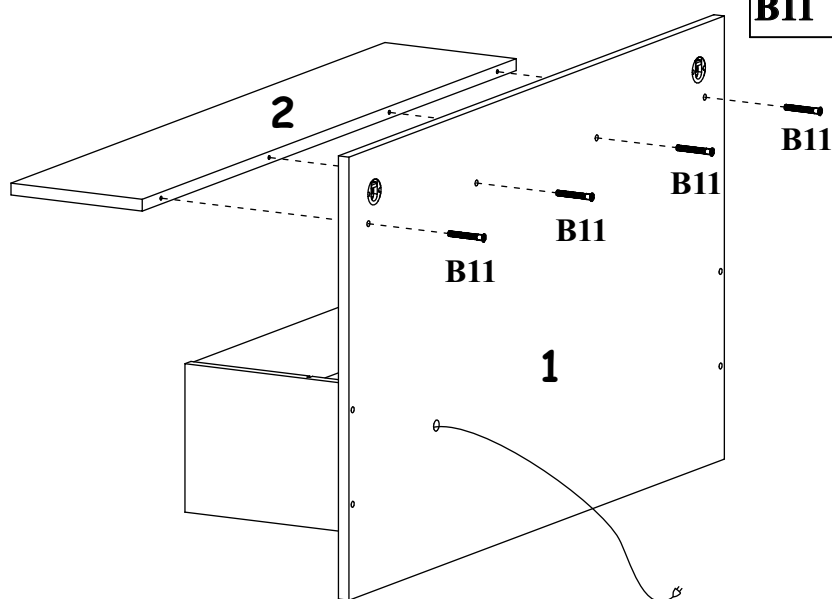

7

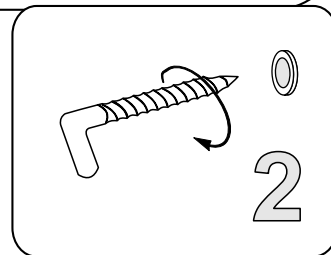
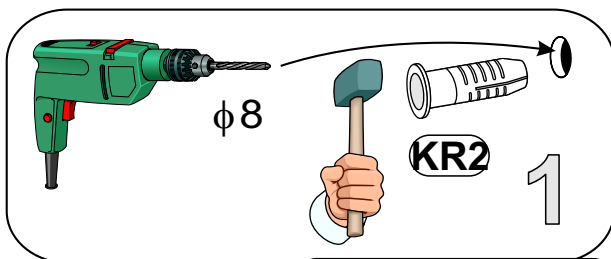
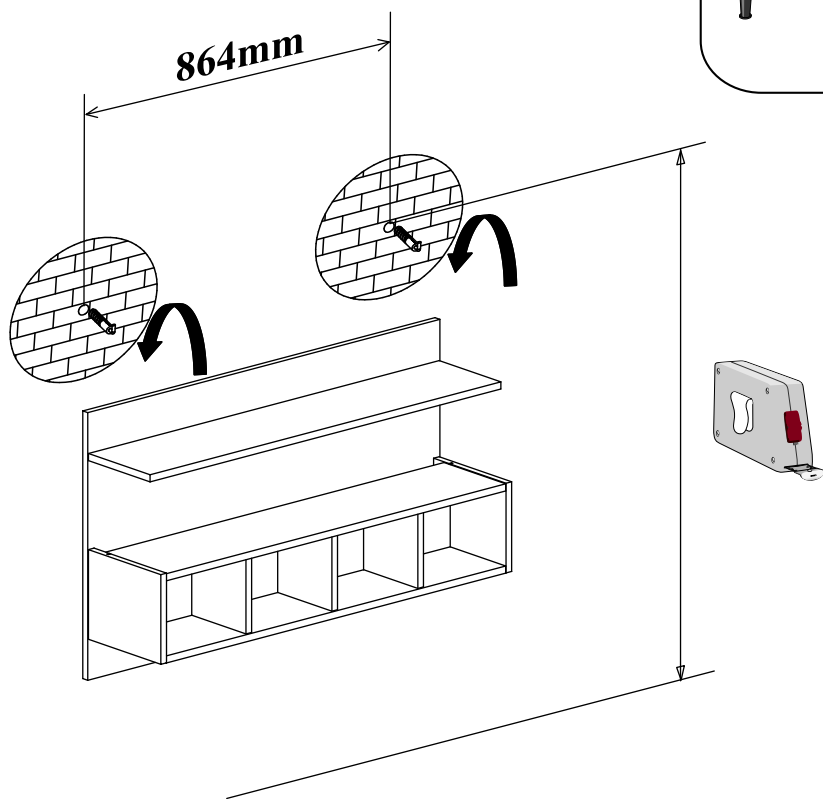

8

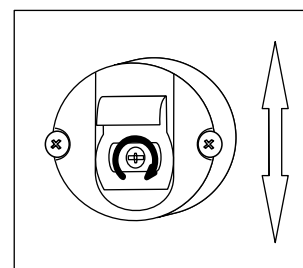
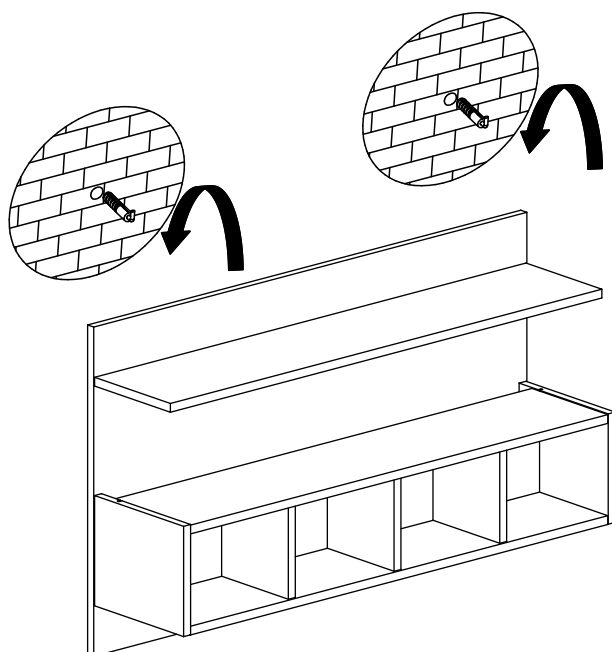

ZM1

