

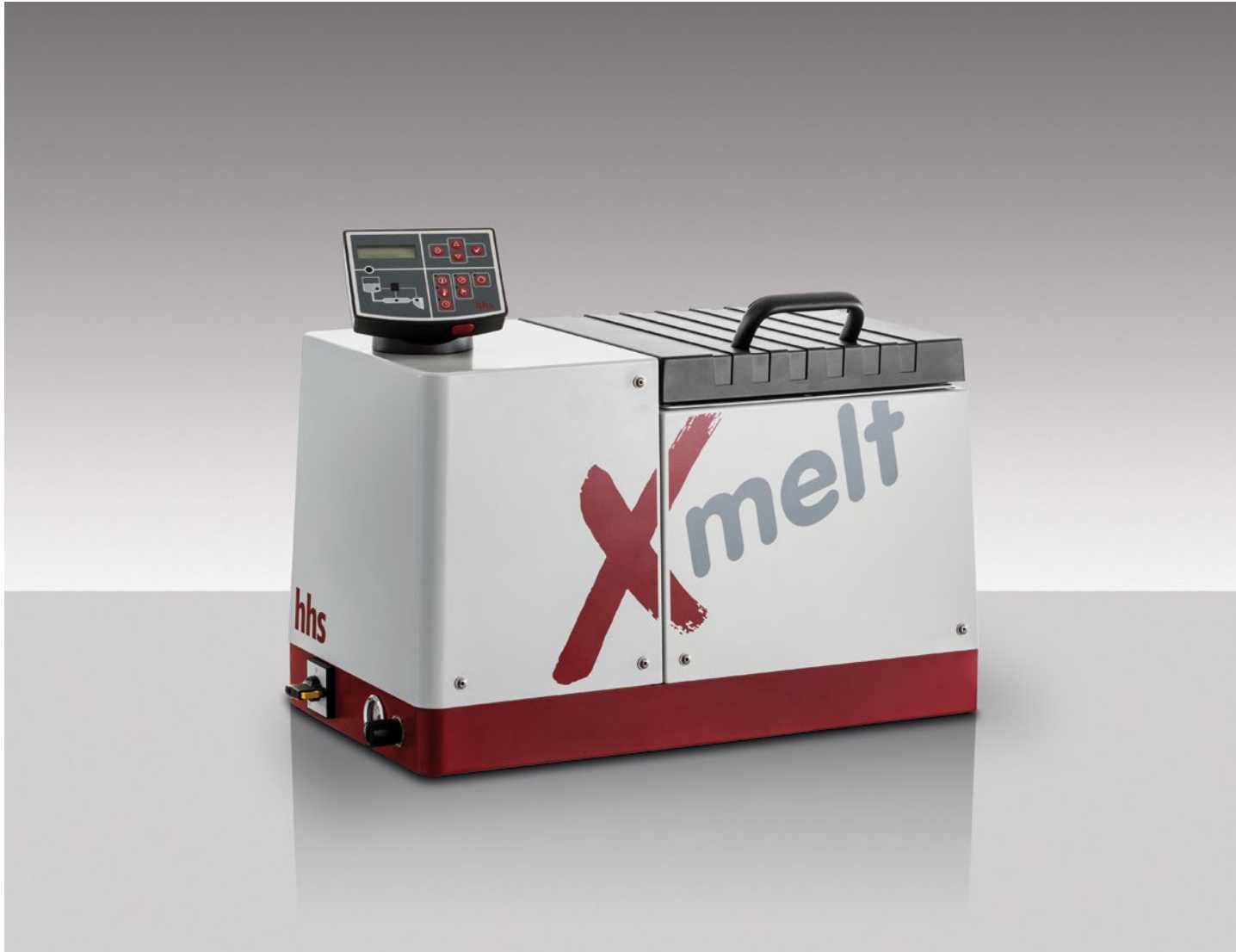

Let's stick together  
(877) 933-3343



**Xmelt**<sup>®</sup>

The melter with intelligence.

# Xmelt® InterActive – the system with intelligence.

## Simple. Safe. Quick.

### Hotmelt application units with PID control in guns, hoses and tank

- pivoting, revolving and detachable control panel
- three level hotmelt filtration
- easily accessible, large-surface filters
- modular system; expansion options
- filling level capacity monitoring (no float switch, no indication error)
- fail safe function due to pneumatic pressure relief
- connection of up to 8 hoses
- variable interfaces for parent machine allow adaptation to future standards
- hose connections in practical delta arrangement
- if requested, an IP converter adapts the glue pressure to the production speed

### Our system grows with your requirements

You don't need to think about future requirements. The Xmelt® hotmelt system keeps growing with you with regards to tank size, hose connections, electronics or communications.

### You were never as flexible in selecting the location

You can pivot, revolve, detach or expand the operational unit by a computer. You can also shift the tank cover stop according to your needs! The Xmelt® melter is smaller than the current industry standard and suits any mounting position.

### Xmelt® protects and saves adhesive

A multi-zone tank heats the glue granules in different zones. The hotmelt achieves required processing temperature at the tank bottom while not melting away at the top. This prevents unwanted charring of the glue and maintains all exterior parts of the unit at harmless temperatures. In addition, this means less energy required, lower wattage, a cooler machine and up to 50 percent savings on time during the heating phase.

### Fail safe

The up to 80 bar high system pressure of the hot glue releases towards the tank during malfunctions, switch off, power failure or

triggered by external signals. The pneumatic pressure relief therefore protects man and machine.

### No jargon

All messages are displayed in plain language. You see immediately what is going on and know what to do. Time consuming and faulty "translations" of codes are not an issue. An unbeatable team with guns and accessories.

### InterActive

This technology allows to exchange references and metered values between Xmelt® melters, hotmelt hoses and application guns. The melter detects all hoses and heads that are connected. Each one transmits its history and allowed parameters.

Thanks to this information the Xmelt® melter can adapt system parameters such as heating algorithms optimally to the connected heads and hoses. Additionally the InterActive technology supports external communication. You as a user can modify data on your computer and even via the internet. On the other end, Baumer hhs can detect problems online and solve them when needed.



Multi-zone compound tank principle

# Thought out to the smallest detail – that is Xmelt® InterActive.

## Modular design

Secure future with Xmelt® – it grows with you and your future production requirements in terms of new products, production sequence or capacity.



## “Non-return” filter cartridge

A ball at the bottom of the filter cartridge closes when the filter is being replaced and prevents leakage of filtered out particles. Replacing the filter only takes seconds due to direct access from the outside.



## Flexible control panel

Swivel, turn, take along, send messages to the computer. Adapt the melter to your ergonomic requirements.



## Refilling without contortions

From the front or back – whatever suits the available space on the unit.



## Quick glue replacement

A special outlet in the area of the hose connections is integrated in the system for quick and controlled glue discharge.



**Xmelt® melters in connection with Xmelt® hotmelt hoses and guns create a hotmelt application system deserving of the name.**

The central melter recognises all connected modules including their history and automatically optimises the system parameters. This makes setting up the system easier, safer and quicker for you.

The Xmelt® melters transform glue granules, pellets or blocks into liquid form and regulate the process pressures as well as the temperatures in the entire system. The melter controls the hotmelt application guns by pumping the liquid through heated

hoses to the independently heated guns where this is applied to the surface of your packaging at optimum temperature and ideal pressure.

## One source for everything

We offer complete solutions for your production.

## We train your team

We offer certified training courses for your technicians and users.



## Technical data

Model <sup>1</sup>	XM-04-2	XM-04-4	XM-04-6	XM-08-2	XM-08-4	XM-08-6	XM-08-8	XM-12-2	XM-12-4	XM-12-6	XM-12-8
Hotmelt output <sup>2</sup>	8 kg/h 17.6 lb/h	8 kg/h 17.6 lb/h	8 kg/h 17.6 lb/h	10 kg/h 22 lb/h	10 kg/h 22 lb/h	10 kg/h 22 lb/h	10 kg/h 22 lb/h	11,2 kg/h 26,64 lb/h	11,2 kg/h 26,64 lb/h	11,2 kg/h 26,64 lb/h	11,2 kg/h 26,64 lb/h
m (kg) m (lb)	28 kg 61.6 lb	28 kg 61.6 lb	28 kg 61.6 lb	33 kg 72.6 lb	33 kg 72.6 lb	33 kg 72.6 lb	40 kg 88 lb	38 kg 83.6 lb	38 kg 83.6 lb	38 kg 83.6 lb	45 kg 99 lb
P <sub>N</sub> (kw)*	4,5	7,4	10,3	4,9	7,8	10,7	13,6	5,3	8,2	11,1	14,0
I <sub>N</sub> (A)*	7	11	13	8	12	16	20	8	12	17	21
IP	40	40	40	40	40	40	40	40	40	40	40
Electrical connection <sup>3</sup>	3/PE AC 200V-230V ±10% 50/60Hz, 3/N/PE AC 230V ±10% 50/60Hz, 1/N/PE AC 200-230V ±10% 50/60Hz, 3/N/PE AC 400V ±10% 50/60Hz										
Compressed air supply	6 bar 87 PSI	6 bar 87 PSI	6 bar 87 PSI	6 bar 87 PSI	6 bar 87 PSI	6 bar 87 PSI	6 bar 87 PSI	6 bar 87 PSI	6 bar 87 PSI	6 bar 87 PSI	6 bar 87 PSI
Temperature range	20-200°C 68-392°F	20-200°C 68-392°F	20-200°C 68-392°F	20-200°C 68-392°F	20-200°C 68-392°F	20-200°C 68-392°F	20-200°C 68-392°F	20-200°C 68-392°F	20-200°C 68-392°F	20-200°C 68-392°F	20-200°C 68-392°F
Control accuracy	±0,5°C ±0,5°K	±0,5°C ±0,5°K	±0,5°C ±0,5°K	±0,5°C ±0,5°K	±0,5°C ±0,5°K	±0,5°C ±0,5°K	±0,5°C ±0,5°K	±0,5°C ±0,5°K	±0,5°C ±0,5°K	±0,5°C ±0,5°K	±0,5°C ±0,5°K
max. hotmelt pressure	max. 80 bar 1.160 PSI	max. 80 bar 1.160 PSI	max. 80 bar 1.160 PSI	max. 80 bar 1.160 PSI	max. 80 bar 1.160 PSI	max. 80 bar 1.160 PSI	max. 80 bar 1.160 PSI	max. 80 bar 1.160 PSI	max. 80 bar 1.160 PSI	max. 80 bar 1.160 PSI	max. 80 bar 1.160 PSI
Ambient temperature	0...50°C 0...122°F	0...50°C 0...122°F	0...50°C 0...122°F	0...50°C 0...122°F	0...50°C 0...122°F	0...50°C 0...122°F	0...50°C 0...122°F	0...50°C 0...122°F	0...50°C 0...122°F	0...50°C 0...122°F	0...50°C 0...122°F
Electrical outputs	8	8	8	8	8	8	8	8	8	8	8
Electrical inputs	4 (potential free)	4 (potential free)	4 (potential free)	4 (potential free)	4 (potential free)	4 (potential free)	4 (potential free)	4 (potential free)	4 (potential free)	4 (potential free)	4 (potential free)

<sup>1</sup>Model name expanded by number of hoses, <sup>2</sup>depending on glue, <sup>3</sup>other voltages with relevant Baumer hhs transformer kit, \*including power consumption of hoses and guns

## Dimensions in mm

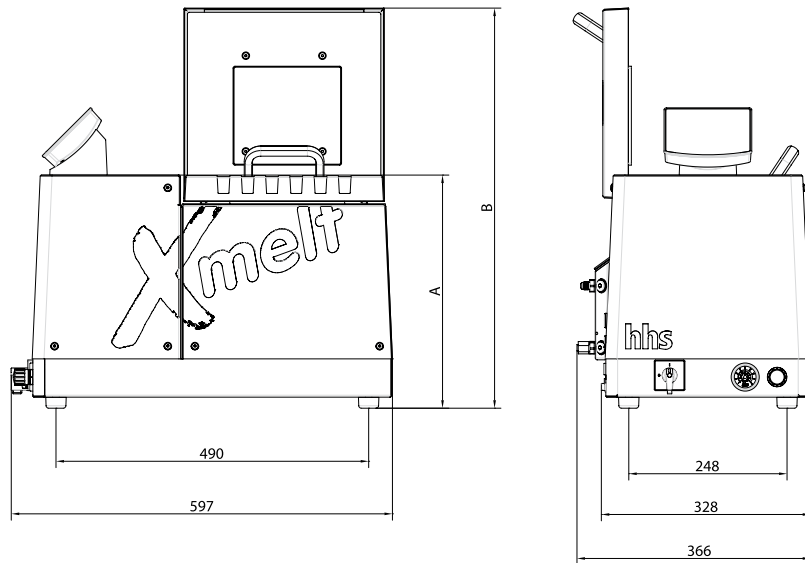

## Tank capacity

Tank capacity	4 kg (8.8 lb)	8 kg (17 lb)	12 kg (26 lb)
A*	370 mm (11.10 inch)	428 mm (12.84 inch)	486 mm (14.58 inch)
B*	625 mm (18.75 inch)	683 mm (20.49 inch)	741 mm (22.23 inch)
Weight <sup>1</sup>	37 kg (81.6 lb)	43 kg (94.8 lb)	45 kg (99.2 lb)

\*valid for up to 6 hose connectors, <sup>1</sup>without tank contents

Further information and product advantages can be found under [www.xmelt.com](http://www.xmelt.com)