



AMERICAN DESIGN. SOLID METAL. BUILT TO LAST.

SHOWER HEAD CARTRIDGE REPLACEMENT MANUAL

YOU MAY NEED:

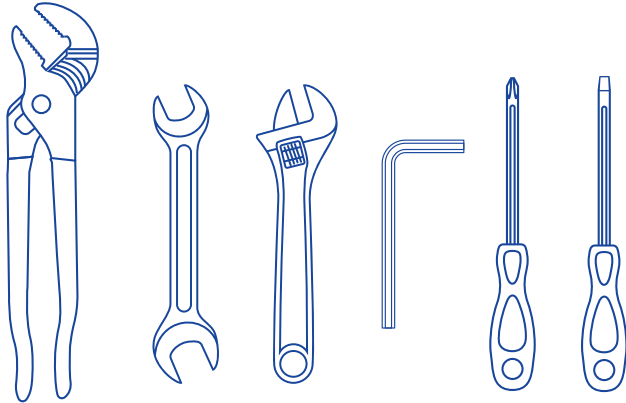

TABLE OF CONTENTS:

WARRANTY.....	PAGE 2
ADJUSTING TEMPERATURE LIMITER.....	PAGE 3
CARTRIDGE REPLACEMENT.....	PAGE 4

To order replacement parts visit: www.theshowerheadstore.com

WARNING: It is essential that the installer properly configures this system/device to maintain a safe, maximum temperature. Adjustments to the configuration could result in an increase in the discharge temperature beyond the safe threshold, potentially causing scalding from hot water.

IMPORTANT MESSAGE FOR INSTALLER: WARNING! – As the person responsible for installing this valve, it falls upon you to ensure that it is correctly **INSTALLED and CALIBRATED** according to the provided instructions. This valve is not designed to automatically compensate for fluctuations in inlet water temperature. As a result, it is crucial to manually adjust the Temperature Limiter at the time of installation. Additional adjustments might be necessary to accommodate for changes in seasonal water temperatures. It is imperative that you communicate this requirement to the owner/user by adhering to the provided instructions. Should there be any uncertainty about how to make these adjustments, please consult page 8.

If questions persist, do not hesitate to contact us at 1-854-888-9231.

CAUTION: Avoid installing a shut-off mechanism on any outlet of this valve. Installing such a device can interrupt the water flow, compromising the valve's capacity to equalize the pressures of the hot and cold water.

CAUTION: This pressure-balanced bath valve aims to reduce fluctuations in outlet water temperature resulting from changes in inlet pressure, typically due to the use of appliances like dishwashers, washing machines, toilets, etc. However, it does not guarantee protection against scalds from hot water in the event of a malfunction of other temperature-regulating devices within the plumbing system, improper adjustment of the rotational limit stop, alterations to the hot water temperature after initial settings have been established, or variations in water inlet temperature caused by seasonal shifts.



HammerHead Showers Limited Lifetime Warranty Information

HammerHead Showers® products have been manufactured under the highest standards of quality and workmanship.

HammerHead Showers® warrants to the original consumer purchaser for as long as the original consumer purchaser owns their home (the "Warranty Period" for homeowners), that this product will be leak- and drip-free during normal use and all parts and finishes of this faucet will be free from defects in material and manufacturing workmanship.

All other purchasers (including purchasers for industrial, commercial and business use) are warranted for a period of 5 years from the original date of purchase (the "Warranty Period" for non-homeowners).

If this product should develop a leak or drip during the Warranty Period, HammerHead Showers® will FREE OF CHARGE provide the parts necessary to put the product back in good working condition and will replace FREE OF CHARGE any part or finish that proves defective in material and manufacturing workmanship, under normal installation, use and service.

Replacement parts may be obtained by emailing HammerHead Showers® at contact@hammerheadshowers.com or calling (854) 888-9231. Proof of purchase (original sales receipt) from the original consumer purchaser must accompany all warranty claims.

This warranty is extensive in that it covers replacement of all defective parts and finishes. However, damage due to installation error, product abuse, product misuse, or use of cleaners containing abrasives, alcohol or other organic solvents, whether performed by a contractor, service company, or yourself, are excluded from this warranty. HammerHead Showers® will not be responsible for labor charges and/or damage incurred in installation, repair or replacement, nor for any indirect, incidental or consequential damages, losses, injury or costs of any nature relating to this product. Except as provided by law, this warranty is in lieu of and excludes all other warranties, conditions and guarantees, whether expressed or implied, statutory or otherwise, including without restriction those of merchantability or of fitness for use.

Some states, provinces and nations do not allow the exclusion or limitation of incidental or consequential damages, so the above limitations or exclusions may not apply to you. This warranty gives you specific legal rights and you may also have other rights which vary from state to state, province to province, nation to nation. HammerHead Showers® will advise you of the procedure to follow in making warranty claims. Simply write to HammerHead Showers® through your order. Explain the defect and include proof of purchase and your name, address, area code and telephone number.

HammerHead Showers®
contact@hammerheadshowers.com
(854) 888-9231

ADJUSTING THE TEMPERATURE LIMITER:

CAUTION: The Temperature Limiter's purpose is to restrict the volume of hot water accessible to reduce the likelihood of scalding injuries, should the control be inadvertently turned to the "hot" extreme during showering or tub filling. The initial factory setting is calibrated to allow a balanced mix of hot and cold water within the system. At this default setting, turning the handle fully to the left for hot water will result in the maximum temperature achievable. Adjusting the Temperature Limiter counterclockwise gradually decreases the proportion of hot water blended into the system. Conversely, turning it clockwise gradually increases the hot water contribution, elevating the risk of scalding should the valve handle be turned fully to the hot position inadvertently during use.

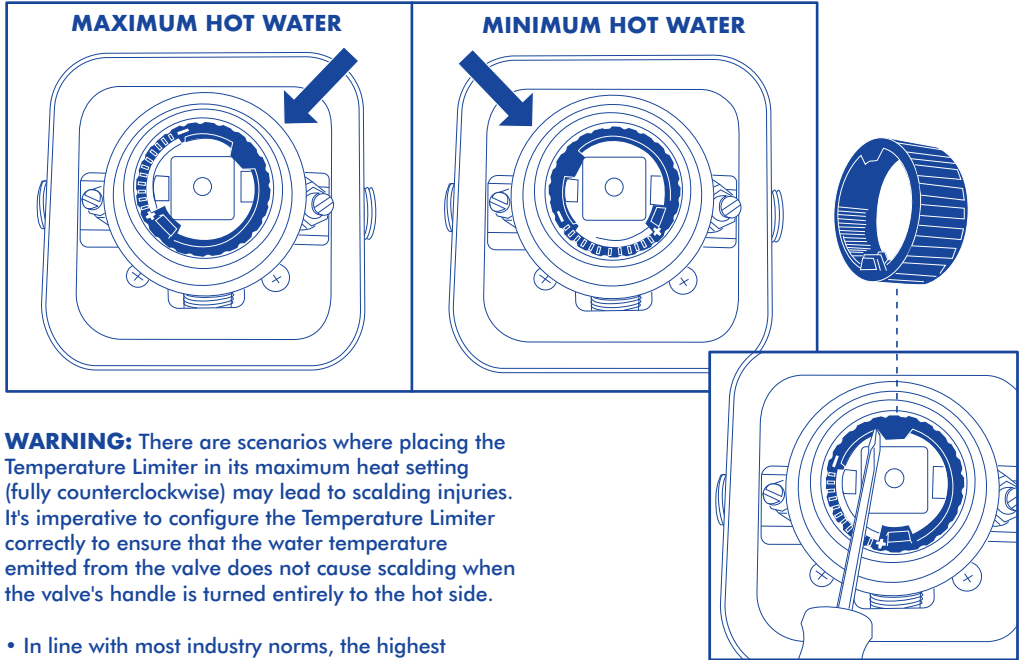

WARNING: There are scenarios where placing the Temperature Limiter in its maximum heat setting (fully counterclockwise) may lead to scalding injuries. It's imperative to configure the Temperature Limiter correctly to ensure that the water temperature emitted from the valve does not cause scalding when the valve's handle is turned entirely to the hot side.

- In line with most industry norms, the highest permissible temperature for water discharged from the valve is set at 120°F.
- Seasonal recalibration of the Temperature Limiter may be necessary due to fluctuations in incoming water temperatures. For instance, the temperature of the cold water during winter months is typically lower than in summer, leading to differences in the mixed water's temperature at the outlet. The ideal temperature range for a comfortable bath or shower usually falls between 90° and 110°F.
- Operate the water to ensure the cold water reaches its minimum temperature and the hot water its maximum. Install the handle onto the stem and turn it counterclockwise to its fullest extent until the handle comes to a stop.
- Insert a thermometer into a plastic cup and hold it under the water flow. Should the water temperature exceed 120°F, it is essential to adjust the Temperature Limiter clockwise to reduce the temperature of the water exiting the valve to below 120°F, or to align with the stipulations of your local plumbing regulations.
- To modify the water temperature output from the valve, pull the red Temperature Limiter (1) out and then rotate it. Turning it clockwise will elevate the temperature at the outlet, while turning it counterclockwise will lower it. The adjustment for each tooth (notch) may vary between 4° and 16°F, dependent on the conditions of the incoming water. Perform adjustments as needed. Once completed, ensure the Temperature Limiter is fully pushed back into its original position.

WARNING: The Temperature Limiter should not be disassembled.

Verify that the water at its highest temperature setting does not surpass 120°F or exceed the maximum temperature permitted by your local plumbing regulations.

CARTRIDGE REPLACEMENT:

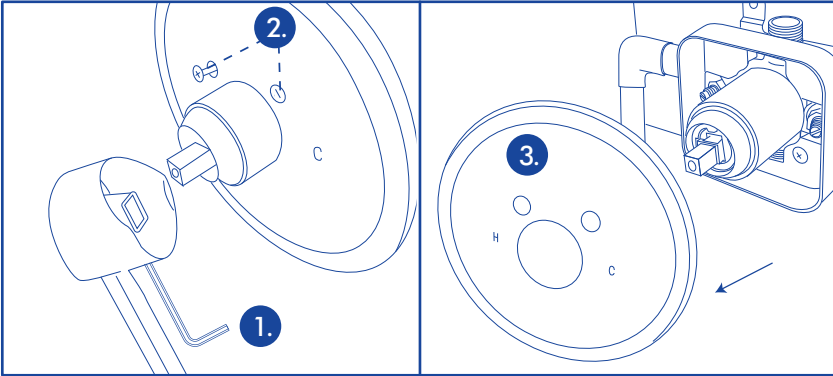

Remove the decorative cap from the hole in the handle. Using an Allen wrench (1) to remove the set screw, pull the handle off the stem. Remove the screws (2) to remove the escutcheon plate (3).

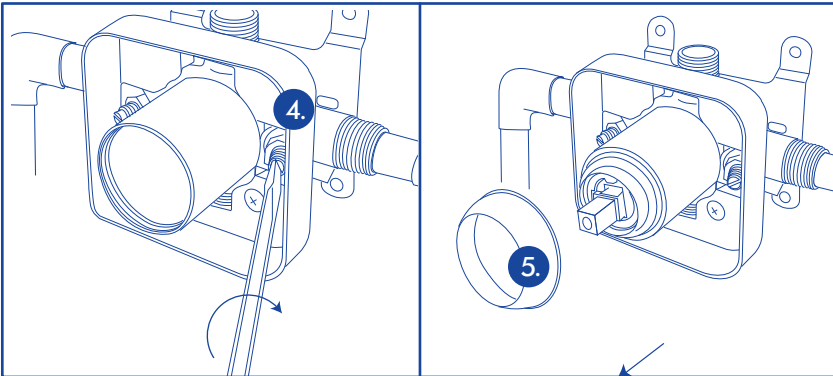

With a flat head screwdriver, close the shut off valves (4) by turning them fully clockwise. Remove the decorative bonnet nut (5) and with an adjustable wrench remove the brass nut (6).

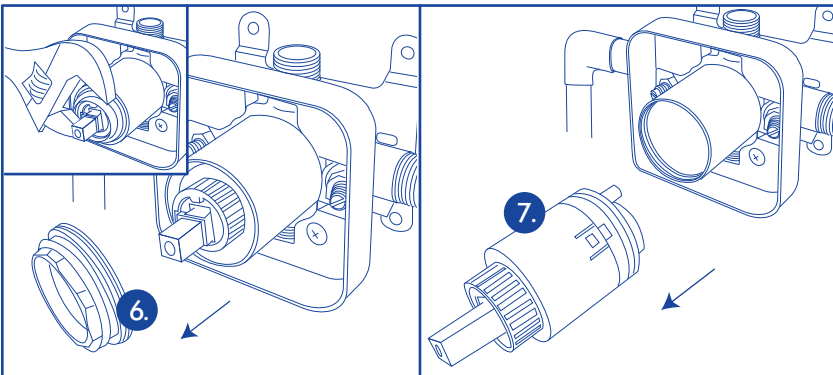

Pull the cartridge out of the valve (7). Ready the surroundings for potential water spray. Gradually open the water supplies to flush the system for 30 seconds.

CARTRIDGE REPLACEMENT cont'd:

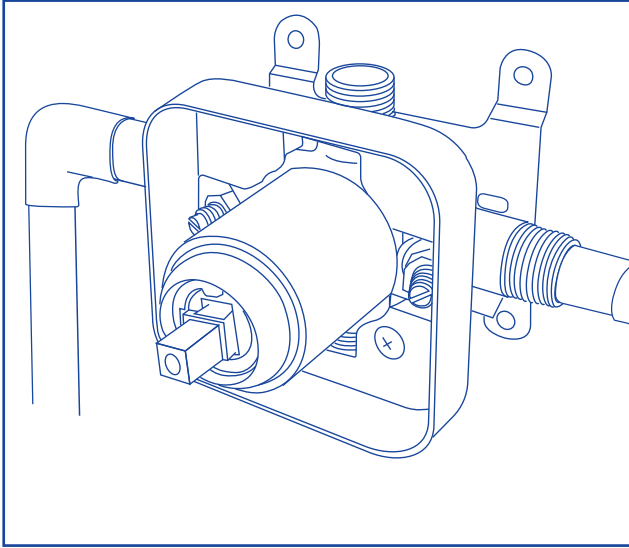

- After flushing, install the cartridge with the alignment pins on the cartridge lined up with the holes on the valve.
- Ensure the cartridge is securely seated inside the valve.
- Thread the brass nut on and tighten with an adjustable wrench.
- Hand tighten the decorative bonnet nut.
- With a flat head screwdriver, slowly open the shut off valves by turning them fully counterclockwise.
- Reinstall the escutcheon plate and handle.



©HammerHead Showers 2024