

# **USERS GUIDE**

---

## **SW-U LCD**



## Content

Preface .....	3
1. Appearance and Size .....	4
1.1 Material and color .....	4
2 Function Summary and Button Definition .....	4
2.1 Function description .....	4
2.2 Monitor Area .....	5
2.3 Button Definition.....	5
3. User reminder .....	7
4. Installation instructions.....	7
5. Operation instructions .....	7
5.1 Power on / off .....	7
5.2 User interface .....	8
5.3 Single Trip / Odometer.....	8
5.4 Current speed / average speed / maximum speed.....	8
5.5 Push Cruise Control .....	9
5.6 Turn on/off Headlight/Backlight .....	9
5.7 PAS Level Selection .....	10
5.7 Battery Indicator .....	10
5.8 Motor Power Monitor .....	10
6 Error Code Information.....	11
7. USB charging function .....	11
8. User settings .....	12
8.1 Preparation before starting .....	12
8.2 General settings.....	12
8.2.1 Trip Distance Clearance.....	12
8.2.2 Backlight brightness setting.....	12
8.2.3 Unit display .....	13
8.2.4 Exit settings .....	13
8.3 Display password setting.....	13
8.3.1 Password use .....	14
8.3.2 Password modification .....	14
8.4 Normal parameter setting.....	14
8.4.1 Wheel diameter setting.....	15
8.4.2 Speed limit setting.....	15

---

8.5 Personalized Parameter Setting .....	16
8.5.1 Personalized password input .....	16
8.5.2 Battery power setting .....	17
8.5.3 PAS level setting .....	17
8.5.4 Current limiting value setting .....	18
8.5.5 PAS sensor setting .....	18
8.5.6 Speed sensor settings .....	19
8.5.7 Throttle function setting .....	20
8.5.8 System settings .....	20
8.5.9 Exit settings .....	22
8.6 Restore default settings .....	22
9. FAQ .....	23
10. Quality assurance and warranty .....	24
11. Version number .....	24
Table 1: Error code definition table .....	25
Table 2: Password quick reference table .....	26
Table 3: Personalized setting table .....	27
Table 4: Default value table of PAS gear ratio .....	29

## **Preface**

Dear user,

To ensure better performance of your e-bike, please read through the SW-U product introduction carefully before using. We will use the most concise words to inform you of all the details (including the hardware installation, setting and normal operation use of the display) when using our display. Meanwhile, the introduction will also help you to solve the possible confusion and malfunctions.

## 1. Appearance and Size

### 1.1 Material and color

SW-U products are made of PC. Under the temperature of -20 to 60°C, the shell material can ensure normal usage and good mechanical performance.

Real product and dimension figure (unit: mm)

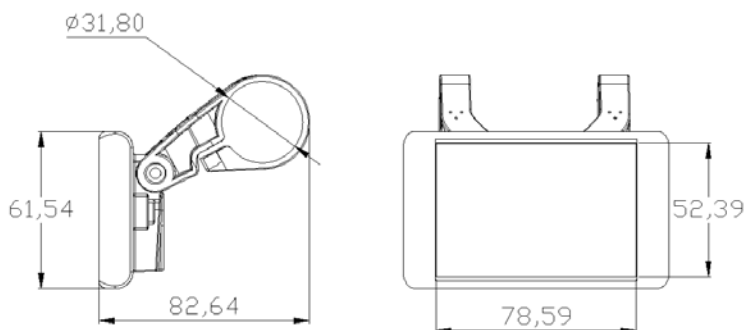

## 2 Function Summary and Button Definition

### 2.1 Function description

SW-U provides a wide range of functions and indicators to fit the users' needs. The indicated contents are as following.

- ◆ Battery Indicator
- ◆ Motor Power Ratio
- ◆ Speed Display (including running speed, max speed and average speed)
- ◆ Trip distance and total distance
- ◆ Cruise control
- ◆ Backlight On/Off
- ◆ Error Code Indicator

- ◆ Various Parameter Setting
- ◆ Recover Default Setting
- ◆ Charging of mobile phone (only for display with USB)

## 2.2 Monitor Area

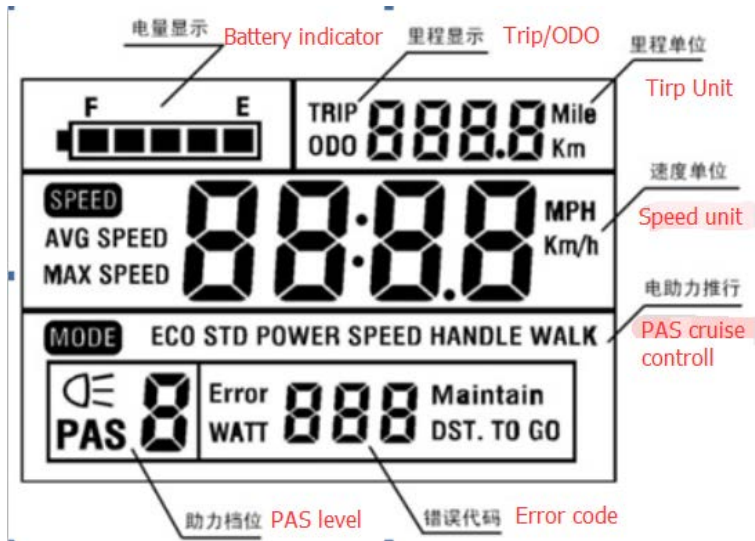

SW-U-II LCD normal monitor interface



## 2.3 Button Definition

SW-U LCD is equipped with special 30 keys or N3 keys. The buttons can be installed on the left side of the handlebar or on the right side of the handlebar.

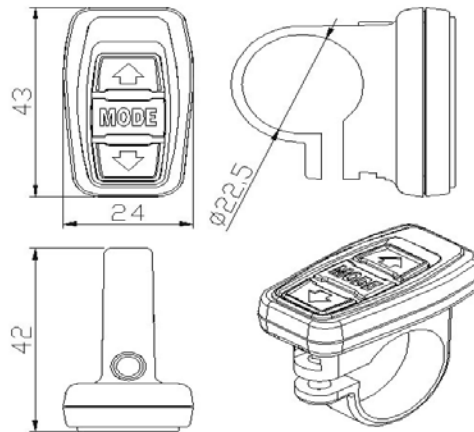
30 button shape is as follows:





N3-button unit is connected to the bottom of the SW-U LCD display via lead cable.

In the following instructions, the key  is named as "MODE". The key  is named as "UP", and the key  is named as "DOWN".

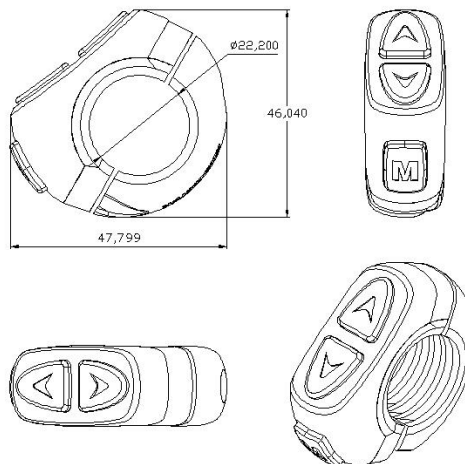
The shape of N3 button is as follows:



N3 key is connected with the bottom lead of SW-U-II display

In the following description, the key  is named as "MODE". The key  is named as "UP", and the key  is named as "DOWN".



## 3. User reminder



Pay attention to the safety during the use of the product, and do not plug or unplug the while the power is on.



Avoid bumps.



The outer shell of the display is waterproof. Please do not disassemble it at will, so as not to affect the waterproof performance of the display.



Please do not change the background parameter setting of the display at will, otherwise it will not guarantee normal riding.



When the display is not working properly, it should be repaired in time.

## 4. Installation instructions

Fix the display onto the handlebar and adjust to an appropriate visual angle. Tighten all the connectors.

## 5. Operation instructions

### 5.1 Power on / off

Hold **MODE** button for 2 seconds then the display will power on, and the display will the power on the controller. With display on, hold **MODE** to turn off power supply of the e-bike. With the display off, the display and controller shut down. The leakage current is less than 1 uA.

When parking e-bike for more than 10 minutes, the display shut down automatically.



## 5.2 User interface

After starting up the display, show the following interface:

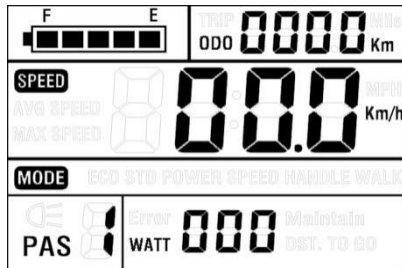

## 5.3 Single Trip / Odometer

Press **MODE** to switch between Single Trip and accumulated total mileage. This function is convenient for users to view the current trip and total mileage (ODO).

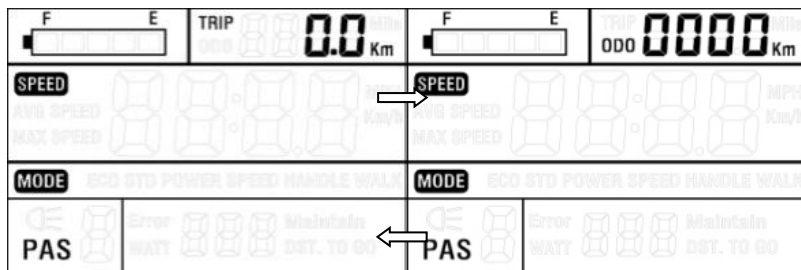

## 5.4 Current speed / average speed / maximum speed

After the display is turned on, the display will show the real-time speed by default.

Press and hold the **MODE** and **DOWN** keys for 2 seconds at the same time to display the average speed (AVG) of the current ride. Press and hold the **MODE** and **DOWN** keys for 2 seconds at the same time to display the maximum speed (max) of the current ride. After pressing the **MODE** and **DOWN** keys for 2 seconds at the same time, it will return to the current speed display.

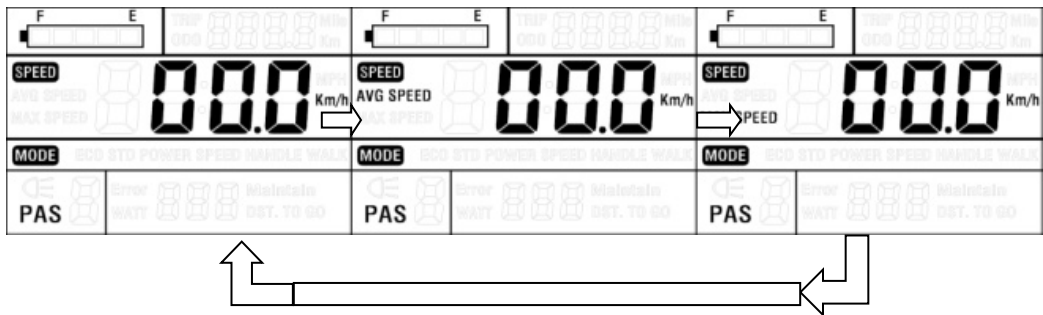

## 5.5 Push Cruise Control

Hold **DOWN** for 2 seconds to enter the mode of power assistant walk. The e-bike will go on at a uniform speed of 6 Km/h. PUS shows on the screen, and the screen shows “WALK” flashing.



6Km/h “Push Cruise Control” function can only be used as pushing the e-bike by hands. Please don’t use this function when riding.

## 5.6 Turn on/off Headlight/Backlight

After pressing the **UP** key for 2 seconds, the display backlight will turn on and the controller will be informed to turn on the Headlight. When the external light is insufficient or driving at night, the LCD backlight can be turned on. Press and hold the **UP** key again for 2 seconds, and the LCD backlight will turn off.

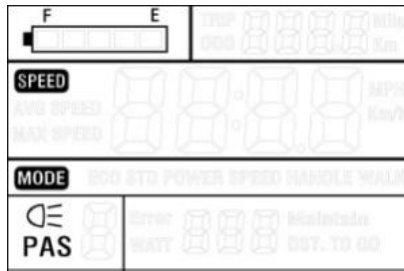

## 5.7 PAS Level Selection

Short press the **UP** or **DOWN** button to switch the power gear of the Ebike and change the output power of the motor. The default output power range of the display is 0-5, and the default gear of the display is 1.

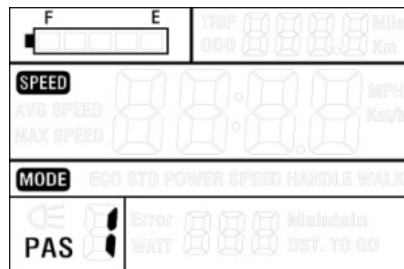

## 5.7 Battery Indicator

The 5 battery bars represent the capacity of the battery. When the battery is in low voltage, battery frame will flash to notice that the battery needs to be recharged immediately.

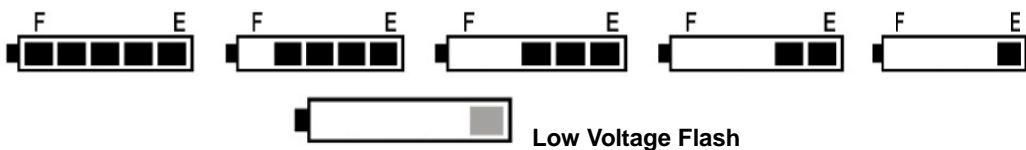

## 5.8 Motor Power Monitor

The display can show the output power of the current motor. The display mode is shown in the following figure.

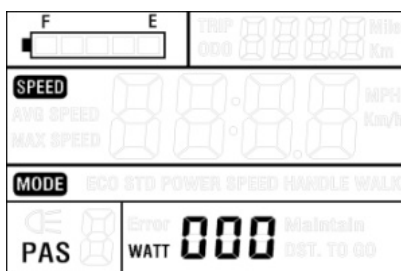

## 6 Error Code Information

If there is something wrong with the electronic control system, the error code will appear automatically. Here is the detail information of the error code in **Table 1** attached.

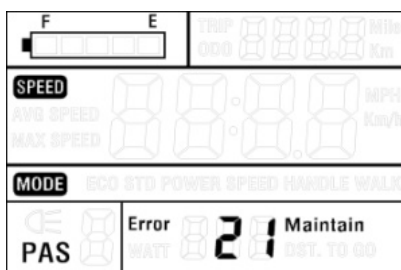

The fault display interface can only be exited when the fault is eliminated, and the Ebike cannot continue to drive after a fault occurs

## 7. USB charging function

Display with USB interface, which provides charging power for mobile phone with output of 5VDC / 500mA. When the display is off, connect the data cable of the mobile phone to the display and the mobile phone. At this time, the display displays "USB" every 3S, indicating that the phone is charging. If the display is turned off at this time, the USB interface still provides the charging function of the mobile phone. In any state, if you unplug the phone, the charging will be terminated automatically.

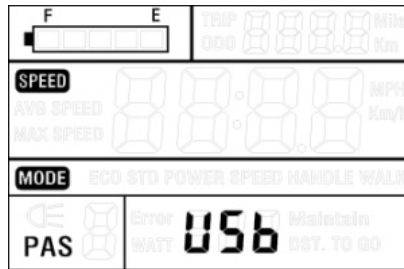

## 8. User settings

### 8.1 Preparation before starting

Make sure that the connector is firmly connected and turn on the Ebike power.

### 8.2 General settings

Press **MODE** button to start the display, then hold both **UP** and **DOWN** for 2 seconds to enter the setting menu.

#### 8.2.1 Trip Distance Clearance

TC means trip distance clearance, and the setting parameter can be n / y. The default n means that the trip of a single ride is not cleared. Y / N can be selected through **UP** / **DOWN**. Y means that the trip of a single ride needs to be cleared, and N means that the trip of a single ride does not need to be cleared.

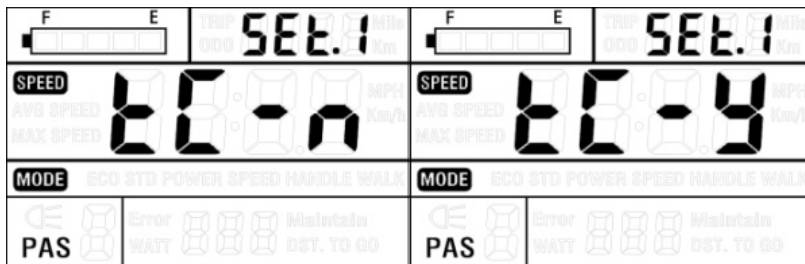

#### 8.2.2 Backlight brightness setting

BL stands for backlight. Setting parameter 1, 2 and 3 can be set to indicate backlight brightness. The default value of the display from the factory is 1. The backlight brightness

setting parameter can be changed by **UP / DOWN**.1 is the darkest and 3 is the brightest.

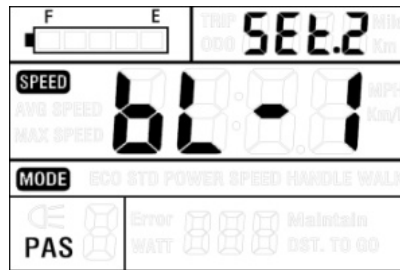

## 8.2.3 Unit display

Setting parameter of metric /imperial unit can be set.The display is metric by default.The metric and imperial unit can be selected by **UP / DOWN**.

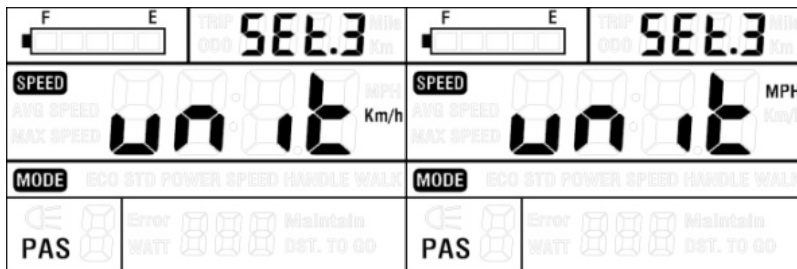

## 8.2.4 Exit settings

In the setting state, short press the **MODE** key to confirm the input and enter the next setting; long press the **MODE** key to save and exit the setting state.

## 8.3 Display password setting

Press and hold the **UP** and **DOWN** keys for 2 seconds to enter the normal setting state; then press and hold the **UP** and **MODE** keys for 2 seconds at the same time to enter the power on password setting state.

The screen prompt "PSD. 2" indicates that you need to input the power on password.Short press the **MODE** key to shift and input the value through **UP / DOWN**.After the 4-digit password is input, press the **MODE** key to confirm.If the password is correct, enter the password setting interface, otherwise it will stay in the password input state.Press and hold **MODE** to exit.Factory default: 1234.

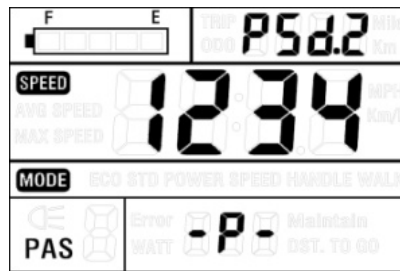

### 8.3.1 Password use

Select Y / N through **UP** / **DOWN**. Y indicates that the power on password is required, and N indicates that the power on password is not required. Short press **MODE** to confirm and enter the display password modification interface.

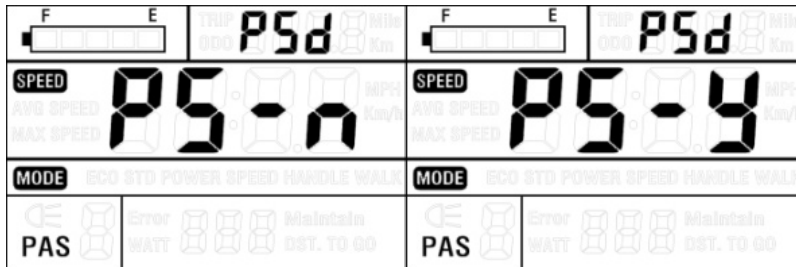

### 8.3.2 Password modification

PSD means password. Short press **MODE** to shift and input the value through **UP** / **DOWN**. After modification, press and hold the **MODE** key to save, confirm and exit the setting state.



### 8.4 Normal parameter setting

Press and hold the **UP** and **DOWN** keys for 2 seconds at the same time to enter the normal setting state; then press and hold the **MODE** and **DOWN** keys for 2 seconds at the same time to enter the use parameter setting state.

The screen prompt "PSD. 1" indicates that the authority password needs to be input. Short press the **MODE** key to shift and input the value through **UP / DOWN**. After the 4-digit password is input, press the **MODE** key to confirm. If the password is correct, enter the password setting interface, otherwise it will stay in the password input state. Press and hold **MODE** to exit. The authority password is: 0512.

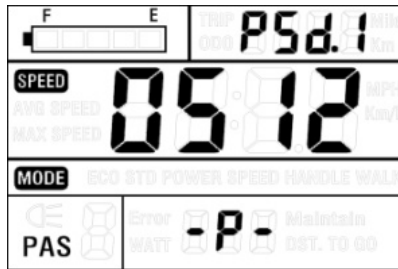

## 8.4.1 Wheel diameter setting

LD indicates wheel diameter setting. The setting values are: 16inch, 18inch, 20Inch, 22inch, 24Inch, 26inch, 700C, 28Inch. Select the wheel diameter corresponding to the Ebike through **UP / DOWN** to ensure the accuracy of display speed display and trip display. Press **MODE** to confirm and enter the speed limit setting interface. The default wheel diameter value of the display is 26inch.

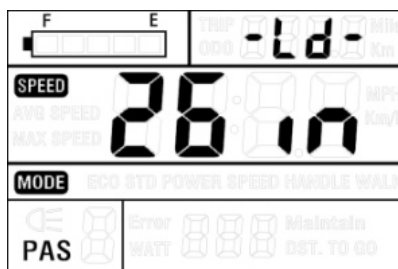

## 8.4.2 Speed limit setting

Ls means speed limit setting. The default maximum riding speed of the display is 25km / h. Changing this value can set the maximum riding speed of the Ebike. When the electric power exceeds the set value, the controller will stop the power supply to the motor to protect the safe riding.

The maximum speed setting value can be selected from 12km / h to 40km / h. It can be set by **UP / DOWN**. After modification, press and hold the **MODE** key to save, confirm and exit the setting state.



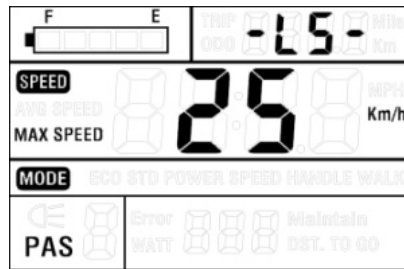

## 8.5 Personalized Parameter Setting

In order to improve the personalized use of this product, we specially add this setting. It can be set according to different requirements of users. This setting includes the setting of battery power bar setting, PAS level, current limit, PAS sensor, speed sensor, Throttle function and system setting. There are seven items in total. See attached **Table 3** for detailed setting items.

### 8.5.1 Personalized password input

Press and hold the **UP** and **DOWN** keys for 2 seconds at the same time to enter the normal setting state; then press and hold the **UP** and **DOWN** keys for 2 seconds at the same time to enter the personalized parameter setting state.

The screen prompt "PSD. 3" indicates that you need to enter the permission password. Short press the **MODE** key to shift and input the value through **UP** / **DOWN**. After the 4-digit password is input, press the **MODE** key to confirm. If the password is correct, enter the password setting interface, otherwise it will stay in the password input state. Press and hold **MODE** to exit. The password is 2962.

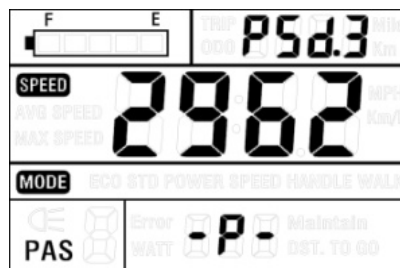

Select the content to be set by **UP** / **DOWN**, and press **MODE** to enter the corresponding setting interface.

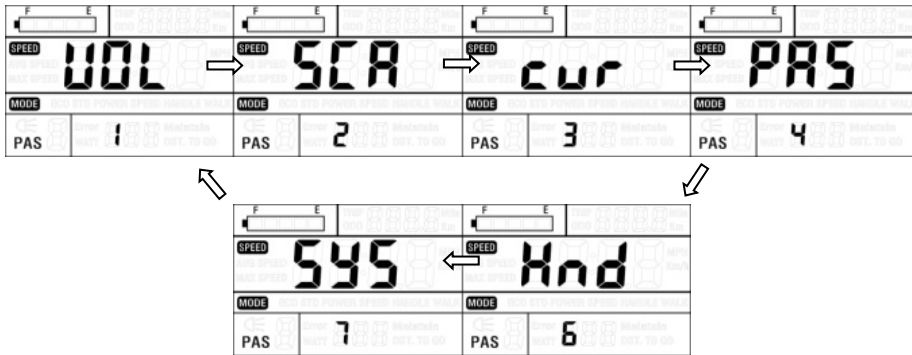

## 8.5.2 Battery power setting

VOL is the battery power setting. The voltage values from 1 to 5 sections are required to be input one by one. Take the first power value as an example: "1" in the screen represents the first voltage and "31.5" represents the first power value. Add / subtract the value through **UP / DOWN**. Short press **MODE** to confirm and enter the setting of the next power value. After setting the five power values, press and hold **MODE** to confirm and return to the display personalized parameter setting interface.

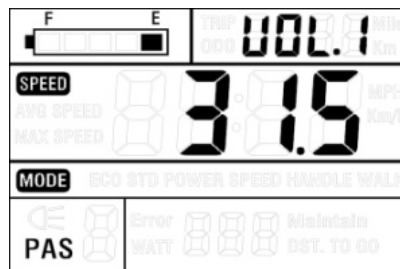

## 8.5.3 PAS level setting

### PAS Level Select

SCA indicates the setting of assist parameter. In Pedal Assistant Level Setting, there are 8 modes to select: 0-3, 1-3, 0-5, 1-5, 0-7, 1-7, 0-9, 1-9. Press UP/DOWN to select the mode, and press MODE to confirm, then change the ratio of each PAS level.

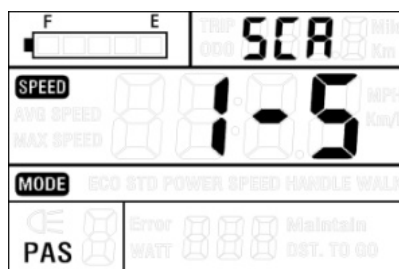

## Assist proportion value setting

The speed of each gear can be adjusted by setting the assist proportion value.To meet the needs of different riders.

Take the first gear as an example, "30:50" is the recommended range of the first gear's assistance proportion, and "40" is the current value of the first gear (i.e. output 40%).Add / subtract by UP / DOWN.Short press MODE to confirm and enter the next assist proportion setting.After setting, press and hold MODE to confirm and return to the display personalized parameter setting interface.Refer to TABLE 4 for details.

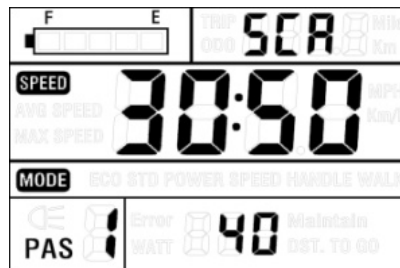

## 8.5.4 Current limiting value setting

Cur is the current limiting setting.The current limit can be set in the range of 7.0-18.0 A.Change the maximum current value of the controller through **UP** / down.Press and hold **MODE** to confirm and return to the display personalized parameter setting interface.The factory default value of the display is 15A.



According to the different controller, the value might not be able to be 18A.

## 8.5.5 PAS sensor setting

### The Direction of Pedal Assistant Sensor Setting

PAS means Pedal Assistant System. "run-F" means forward direction, while "run-b" means back direction. Press **UP/DOWN** to select F or b, and press **MODE** to confirm and turn to PAS sensitivity setting. The default direction is forward.

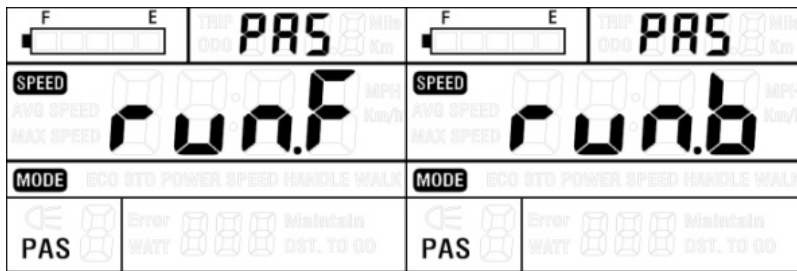

### The Sensitivity of PAS Setting

SCN means the sensitivity of PAS, and 2 to 9 can be selected. 2 is strongest, 9 is the weakest. **UP/DOWN** is to select sensitivity value, and **MODE** is to confirm selection and turn to magnet disk setting. SCN default value is 2.

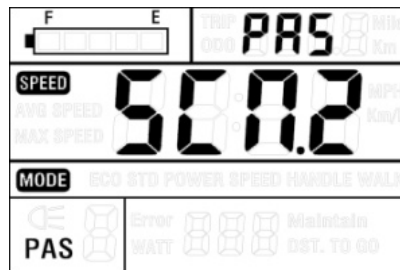

### Proportion parameters Setting of PAS

N - denotes the proportional parameter of the PAS sensor. The parameter value can be selected through **UP / DOWN**. The larger the value, the more obvious the feeling of assistance. Press and hold **MODE** to confirm and return to the display personalized parameter setting interface.

### 8.5.6 Speed sensor settings

SPS means Speed Sensor. Press **UP/DOWN** to select the quantity of magnet head (the range is from 1 to 9), and press **MODE** to confirm and turn to Throttle Definition page. SPS default value is 1.

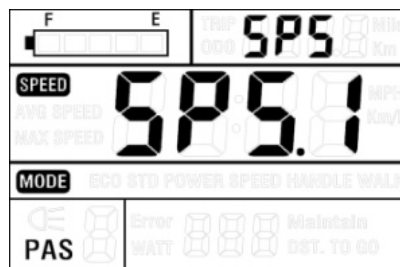

## 8.5.7 Throttle function setting

### Throttle Enable/Disable

HL means that the throttle pushing assist .HL: n indicates that the throttle has no pushing assist function, and HL: y indicates that the throttle has a pushing function, that means, when the handle is turned, the display will enter the pushing assist mode.Y / N can be switched through **UP** / **DOWN**.If n is selected, press **MODE** to confirm and enter into the setting interface of handle vector, otherwise, there is no response.Press and hold **MODE** to confirm and return to the display personalized parameter setting interface.The factory default value of the display is n.

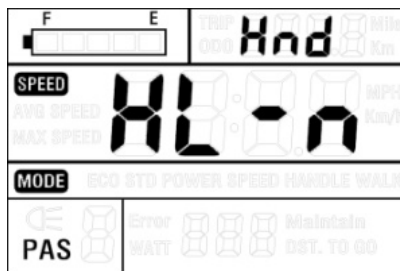

### Throttle vector Enable/Disable setting

HF means the throttle vector setting. HF-y means the throttle vector enable, HF-n means that throttle vector disable.

HF-y means that when the throttle is turned, the maximum speed can only reach the corresponding speed corresponding to the gear shown on the display.

HF-n means that the bike can reach the max speed and it is not affected by the gear limit shown on the display when turning the throttle

Press and hold **MODE** to confirm and return to the display personalized parameter setting interface.The factory default value of the display is n.

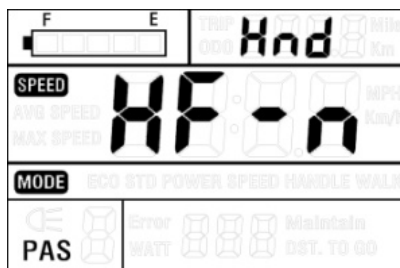

## 8.5.8 System settings

### Delay time setting of battery power

Dy means delay time of battery power.Through **UP** / **DOWN**, the power delay time can be

selected as 3 / 6 / 12s.Short press **MODE** to confirm and enter the max speed limit setting interface.The default time is 3S.

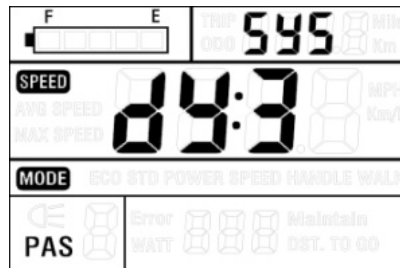

### Max speed limit setting

Max speed indicates the maximum speed limit.The maximum speed limit value can be set by **UP/ DOWN**, and the setting range is 25-40 km / h.Short press **MODE** to confirm, and enter the" button PAS setting" interface.The default setting is 40km / h.

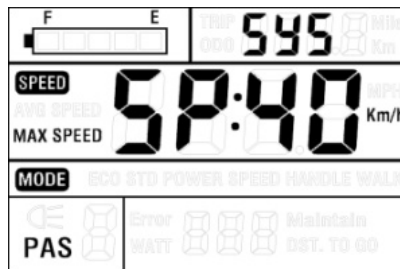

This setting parameter is the upper limit number specified by the display manufacturer

### Button PAS Setting

PUS means pushing. Press **UP/DOWN** to choose Y/N.

Short press **MODE**, Y means enable, N means disable.

Short press **MODE** to confirm and enter into PAS speed setting. The default value is Y.

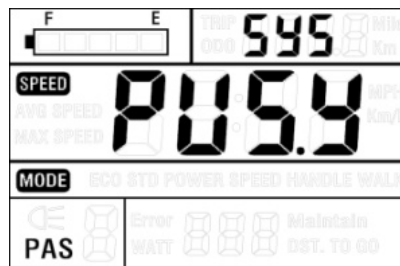

### PAS Speed setting

Pu indicates the speed setting of button pushing.By setting the button pushing speed value, the pushing speed can be adjusted to meet the needs of different riders.Through **UP / DOWN**, the adjustable range is "20-35".Short press **MODE** to confirm and enter the slow start up

setting interface.The default value of the display is 25 (output 25%).



### Slowly start up setting

SSP indicates the slowly start up setting. The adjustable range is 1-4.

4 is the slowest. Select by **UP** / **DOWN**. Press and hold **MODE** to confirm and return to the display personalized parameter setting interface .The factory default 1.

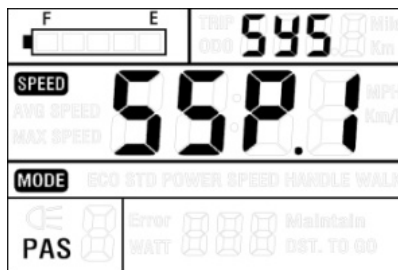

### 8.5.9 Exit settings

In the personalized parameter setting state: short press **MODE** to confirm input to enter the next setting; long press **MODE** to confirm saving the current setting and exit the current setting state; long press **DOWN** to cancel the current operation and exit without saving the current setting data.

Without any operation within one minute, the display will automatically exit the setting state.

### 8.6 Restore default settings

DEF means to restore the default parameter .Press and hold the **UP** and **MODE** keys at the same time for 2 seconds to enter the interface of restoring default parameter .Switch y or N through **UP** / **DOWN**.Y indicates that the default parameter need to be restored. Press and hold **MODE** to confirm .If you select y, you need to enter the permission password to restore the default parameter.

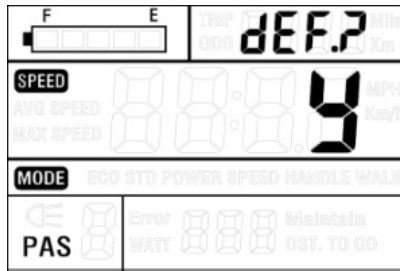

The authority password is: 0368. Short press **MODE** to shift and input the value through **UP** / **DOWN**. After the 4-digit password is input, short press **MODE** to confirm. The display will exit automatically after successful recovery.

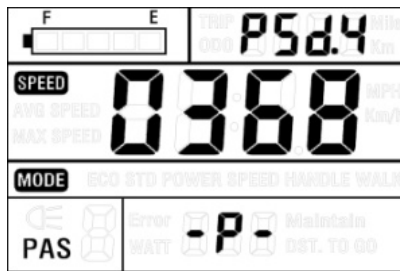

In default, the battery power, total mileage and single trip are not recoverable, and the power-on password is in the list of recovery.

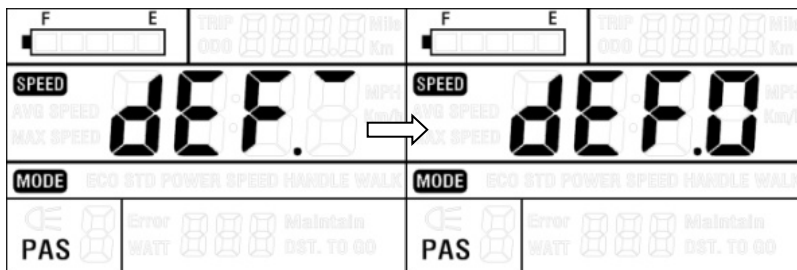

## 9. FAQ

Q: Why the display is not able to start up?

A: Check the connector between display and controller.

Q: How to deal with the error code?

A: Fix it to the maintenance place immediately.



## **10. Quality assurance and warranty**

### **I、Warranty**

- 1、 Any quality problems in normal case and during guarantee period, our company will be responsible for the warranty.
- 2、 The warranty time is 24 months when display out of the factory.

### **II、Other items**

The following items do not belong to our warranty scope.

- 1、 It can not be demolished.
- 2、 The damage is caused by wrong installation or operation.
- 3、 Shell is broken when display is out of the factory.
- 4、 Wire is broken.
- 5、 The fault or damage is caused by the force majeure (such as fire, earthquake, etc.) or natural disasters like lightning, etc.
- 6、 Beyond Warranty period.





## **11. Version number**

This operating instruction is a general-purpose version of KING-METER TECHNOLOGYCO.,LTD (V1.0) .Some of the version for the display software will be different from the specification, which should depend on the actual use version.



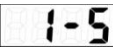









**Table 1: Error code definition table**

Error Code	Definition
21	Current Abnormality
22	Throttle Abnormality
23	Motor Abnormality
24	Motor Hall Signal Abnormality
25	Brake Abnormality
30	Communication Abnormality

**Table 2: Password quick reference table**

No.	Screen display	password	Meaning
1		0512	Using parameter setting password(fixed)
2		Factory default 1234	Power on password (modifiable)
3		2962	Personal parameter setting password (fixed)
4		0368	Restore settings password (fixed)

**Table 3: Personalized setting table**

No.	Set item	Screen display	Set content
1	Battery power setting		Five battery power value 
2	Power gear setting		Power assist level selection 
			Assistance proportion 
3	Current limiting setting		Limiting current 
4	Booster sensor settings		PAS direction 
			PAS sensitivity 
			
5	Speed sensor settings		Speed sensor magnet No 

**Continued Table 3:**

No.	Set item	Screen display	Set content
6	Throttle turning function	Hnd	Throttle Enable/Disable HL-n
			Throttle vector Enable/Disable setting HF-n
7	System settings	SYS	Time of battery power delay dY:3
			Max speed setting SP:40
			Button pushing setting PU54
			PAS Speed setting PU:25
			Slowly start up settings SSP.1

**Table 4: Default value table of PAS gear ratio**

Gear Gear options	1	2	3	4	5	6	7	8	9
0-3/ 1-3	47%	72%	92%	—	—	—	—	—	—
0-5/ 1-5	40%	55%	70%	85%	95%	—	—	—	—
0-7/ 1-7	35%	46%	57%	68%	79%	90%	97%	—	—
0-9/ 1-9	25%	34%	43%	52%	61%	70%	79%	88%	96%

***KING-DISPLAY***