

## 50Ω DC~8GHz, Low Noise, Flat Gain LNA

Case PN: 6GD4W6H41SA20

## Features:

- \* Frequency Range: DC to 8 GHz
- \* Noise Figure: typical 1.8 dB @ 4 GHz
- \* Gain: 39 dB Gain at 4 GHz
- \* Flat Gain: +/-1dB from DC to 8GHz
- \* +18 dBm P1dB & +20 dBm PSat
- \* +31 dBm OIP3 at 145mA current
- \* +5.5~12V Supply, ROHS Compliant
- \* Input & Output DC-Blocked
- \* EMI Shielded & Waterproof Option Available (PN#: LADC8G2SRW)
- \* Two Female SMA Connectors for RF In/Out

## Applications:

- \* Mobile Infrastructure
- \* General Purpose Wireless
- \* Test Instrumentation



## General Description:

**LADC8G2SR** is a flat gain, high-linearity, low noise amplifier covering up to 8GHz. It is in a small 1-1/2"x15/16"x0.49" shielded RF enclosure. The LNA provides a +/-1.0dB flat gain (peak-to-peak) from DC to 8 GHz. At 4 GHz, the amplifier typically provides 39 dB gain, +31 dBm OIP3 at a 145mA bias setting, and 1.8 dB noise figure. The LNA can be biased from a single supply +5.5V~12V.

## Electrical Specifications:

Item	Parameter	Condition	Electrical Specification			
			MIN	TYP	MAX	UNITS
1	Frequency		DC		8000	MHz
2	Gain		38	39	41	dB
3	Noise Figure		1.7	1.8	3.0	dB
4	Output P1dB			+18		dBm
5	Input Return Loss			12.5		dB
6	Output Return Loss			11		dB
7	Pin max without damage			+25		dBm
8	Gain Flatness	+/-1.0dB p-p, 0.2 dB p-p over any 30 MHz				
9	Output IP3			+31		dBm
10	Voltage		5.5	6	12	V
11	Operating Current (Quiescent)			145		mA
12	Environmental Rating	IP67 (Option)				
13	Operating Temperature		-40		+85	Deg C

## Absolute Maximum Ratings

Item	Parameter	Rating	UNITS
1	Max Device Voltage	+15	V
2	Max Storage Temperature	-55 to +150	°C

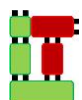

**Lotus Communication Systems, Inc.**

[www.lotussys.com](http://www.lotussys.com) 531 Main St Unit G, Acton, MA 01720 (508) 655-1998

Rev. A LADC8G2SR

sales@lotussys.com

Outline Drawing (inch)

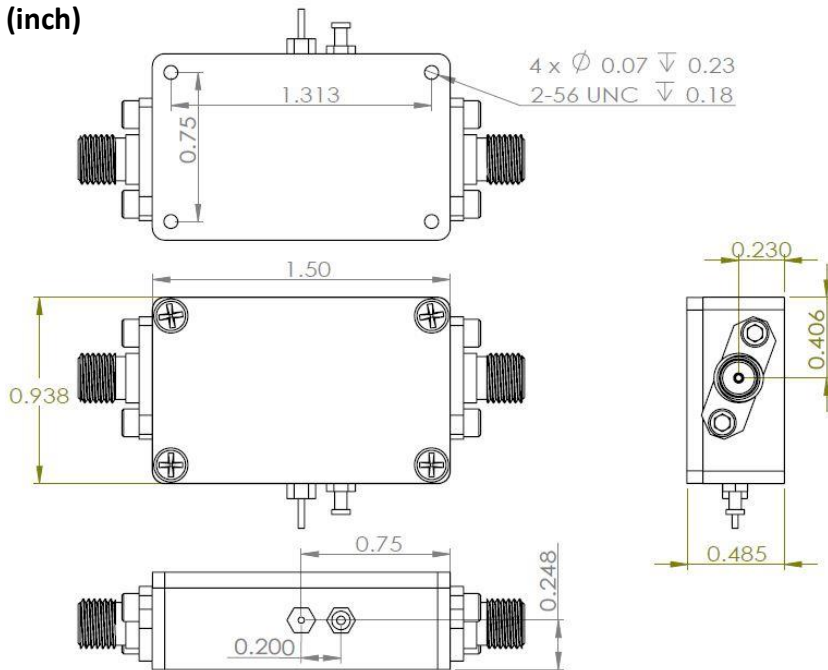

S-Parameters

