

A PERSONAL MESSAGE FROM OUR FOUNDER

When I shop, I am not just buying a product or service. I purchase why that brand focuses on what they do, what their corporate philosophy is, the quality of their products, and whether or not my personal core values align with that brand's vision. When I don't feel great about a company's brand, products, or how I'm being treated as a customer, then I know they are not delivering on what matters most: exceeding the customer expectation by delivering happiness with their products, quality, and service.

This primary focus is what drives our culture at Team Skybound. For supporting our vision, we would like to personally thank you for trusting us to deliver happiness to you and your family!

-Kiki (Founder) & Team SkyBound

"Nurturing the inner-child in all of us by uniting communities worldwide and promoting an active lifestyle."

For customer service, please contact:

888-891-4689

Monday through Friday
8:00 am to 5:00 pm PST

or visit www.SkyBoundUSA.com
or www.TrampolinePartsCenter.com



help@skyboundusa.com

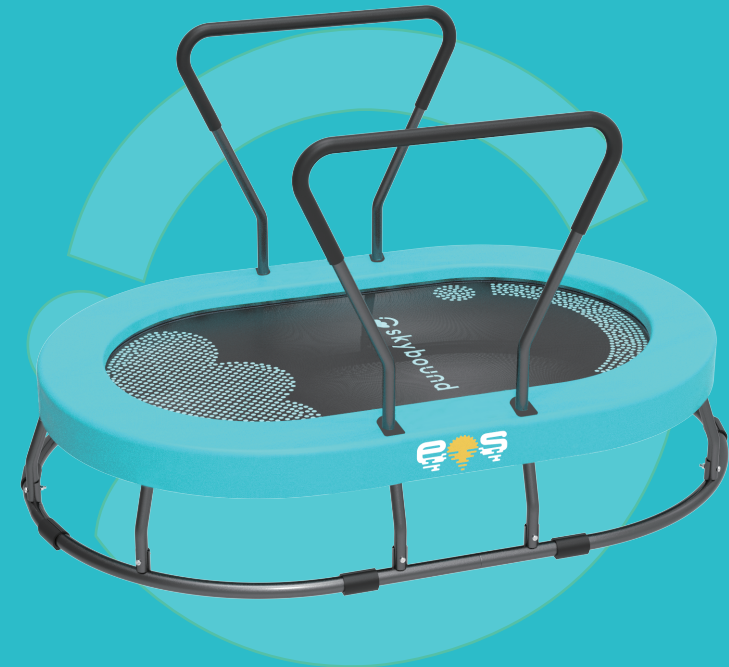

SENSORY OVAL TRAMPOLINE

ASSEMBLY AND INSTALLATION MANUAL

www.SkyBoundUSA.com
www.TrampolinePartsCenter.com

IMPORTANT INFORMATION

WARNING

- Prior to assembling or using the trampoline, you must thoroughly read this manual.
- Keep this manual for future reference.
- This product is intended for domestic family use only.
- Adult supervision is required at all times.
- This trampoline is not intended for use by more than one person at any time.
- This product is recommended for use by children 3 - 10 years of age.
- Maximum weight of the user not to exceed 150 lbs (68 kgs).

This object is subject to wear and tear. No warranties whether expressed or implied are provided. Injury will likely occur with the use of a trampoline or any associated product.
Use with supervision. Use at your own risk.
Only Use in a well-lit, well secured down area.

WARNING - GENERAL

Prior to using the sensory trampoline, you must read all the instructions contained in this manual. All information, including the warning instructions for care, maintenance, and use of the sensory trampoline are intended to promote safe, enjoyable use of the sensory trampoline.

- Users should consult with a physician before beginning any exercise or conditioning program.
- If user feels faint or dizzy, immediately stop using the sensory trampoline.
- Avoid bouncing when tired. Take breaks often.
Use only in a well lit area by responsible, mature, non-intoxicated persons.
- Never use sensory trampoline on an un-level surface. Use only when dry.
- Overhead clearance is essential. A minimum of 10 feet of overhead clearance from ground level is required.
- Provide clearance from all surroundings and obstructions such as desks, chairs, trees, poles, wires, and other possible hazards.
- Lateral clearance is essential. Place the sensory trampoline away from walls, structures, doors, and other play areas. Maintain a clear space on all sides of the trampoline.
- Place the sensory trampoline on a stable level surface before use.
- The area under the trampoline should be free and clear of any objects or obstructions.
- Secure the sensory trampoline against unauthorized and unsupervised use.
- Remove any obstructions from beneath the sensory trampoline.
- The owner and supervisors of the sensory trampoline are responsible for all users to be aware of the practices specified in the use instructions.
- This product is not intended for use by children under 3 years of age.
Restrict usage to one person at any time.
- Maximum weight limit is 150 lbs (68 kgs).
- Prior to each use, inspect the sensory trampoline for any worn, defective, misadjusted or missing parts. Ensure the frame and mat are correctly and securely positioned.

IMPORTANT INFORMATION

WARNING - USAGE

- DO NOT attempt or allow somersaults. Landing on the head or neck can cause serious injury, paralysis, or death even when landing in the middle of the bed.
- DO NOT allow more than one person on the sensory trampoline. Use by more the one person at the same time can result in serious injury.
- Use sensory trampoline only with mature, knowledgeable supervision at all times.
- Inspect the sensory trampoline before each use. Make sure the frame padding is correctly and securely positioned. Replace any worn, defective, or missing parts.
- Step on and off the sensory trampoline. Do not step on the frame when getting on and off the sensory trampoline. Do not use the sensory trampoline as a springboard to other objects. Do not mount or dismount the sensory trampoline by jumping.
- Stop bounce by flexing knees as feet come in contact with the sensory trampoline bed. Learn this skill before attempting others more advanced moves. Control is more important than bounce height.
- For information concerning skill training, contact a qualified fitness trampoline instructor.
- Store and protect sensory trampoline from unauthorized use.
- Read all instructions before using the sensory trampoline. Warning and instructions for the care, maintenance and use of this sensory trampoline are included to promote safe, enjoyable use of the equipment.
- Remove any sharp or loose objects from pockets or on your body prior to use, such as glasses, watches, jewelry, chains, ornaments, clasps, and other sharp objects.
- Ensure the trampoline and surrounding areas are properly illuminated.
- Serious injury can occur from misuse or abuse of the sensory trampoline. bounce in the center of the bed.
- For additional information, contact us at help@Skyboundusa.com or (888) 891-4689

CARE, MAINTENANCE AND USE INTRUCTIONS MUST BE READ CAREFULLY PRIOR TO USING THE TRAMPOLINE!

This trampoline is constructed of high quality materials and craftsmanship. For years of exercise, fun and enjoyment and to reduce the risk of injury to the user, follow all required care and maintenance instructions closley listed below:











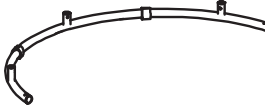

- Only one jumper should use the sensory trampoline at any time.
- Do not allow pets on the sensory trampoline in order to help prevent cuts, scrapes, tears or other types of damage to the mat or bands.
- Inspect the sensory trampoline before each use and replace any worn defective, or missing parts. Any number of issues can raise the risk of injury.
- The following conditions could represent potential hazards:
 1. A bent or broken frame
 2. Fraying elastic bands
 3. A sagging mat
 4. Sharp protrusions on the frame or suspensions system

IF ANY OF THE PREVIOUS CONDITIONS ARE FOUND, OR ANY OTHER ISSUES YOU MAY FEEL MAY BE HARMFUL TO THE USER, THE SENSORY TRAMPOLINE SHOULD BE IMMEDIATELY DISASSEMBLED OR SECURED FROM ANY FUTURE USE UNTIL THE

You must check all the parts of the sensory trampoline including the frame, suspension system, mat, and legs at regular intervals.
If these checks are not carried out, the trampoline could become dangerous.

ASSEMBLY PARTS

ASSEMBLY INSTRUCTIONS

NO.	Part Name	Pictures	Quantity
1	Upper Assembly Frame		1
2	Spare Elastic Rope		2
3	Bend Connecting		6
4	Straight Connecting		4
5	Lower Coil Pipe 1		2
6	Lower Coil Pipe 2		2
7	Piece Pad		1
8	Armrest Left Tube		2
9	Armrest Right Tube		2
10	Bolt		2
11	Hexagon Socket Bolt (M5*16mm)		14
12	Washer (M5)		14
13	L Wrench		1

STEP 1

Unfold Part 1 as shown in the figure below.

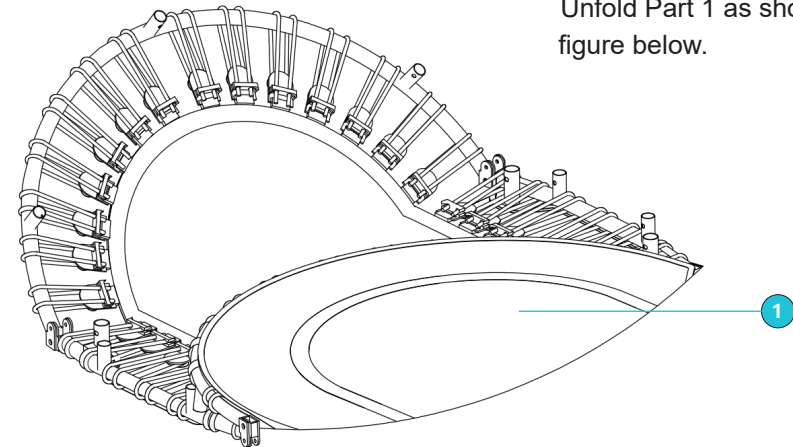

STEP 2

Insert bolt (part 10) to open slots of Part 1 as shown in figure.

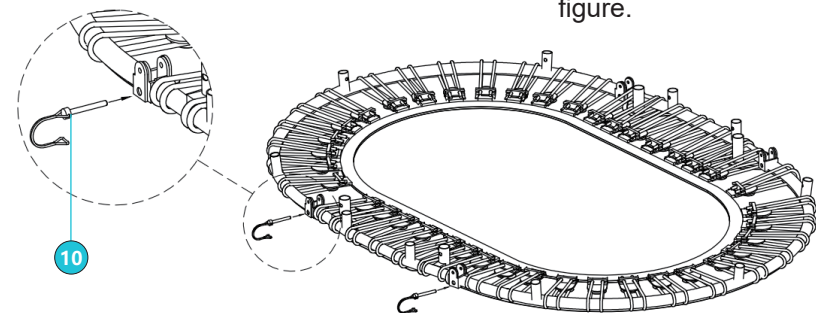

ASSEMBLY INSTRUCTIONS

STEP 3

Insert Bent Rod (Part 3) to slots on outside curve of Part 1. Insert Straight rod (Part 4) to middle two slots of Part 1. As shown in figure

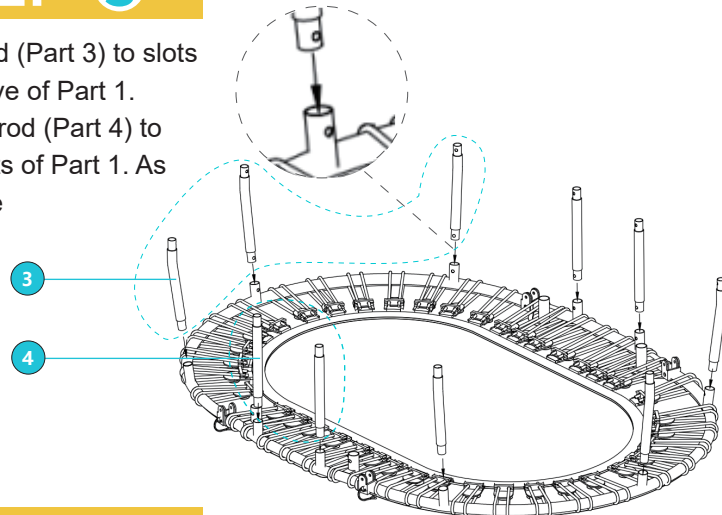

STEP 4

Connect Parts 5 and 6 and then lower the connected parts onto both bent (part 3) and straight (part 4) rods. As shown in the figure.

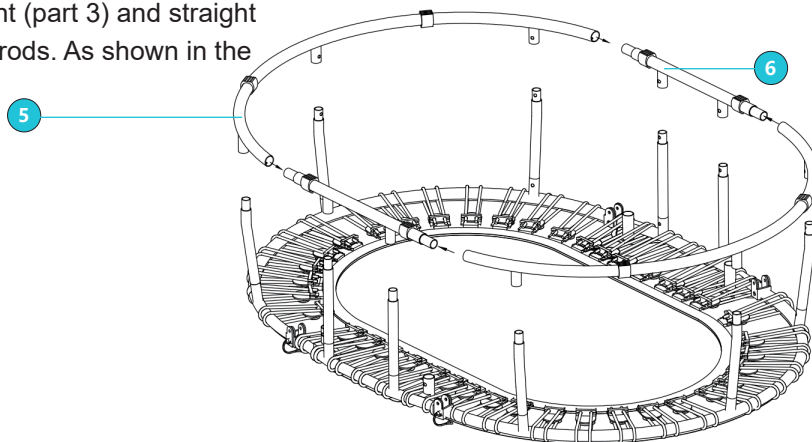

ASSEMBLY INSTRUCTIONS

STEP 5

As shown in the figure use hexagon bolt (part 11) and washer (part 12) to secure parts 5 and 6 to parts 3 and 4. As shown in the figure.

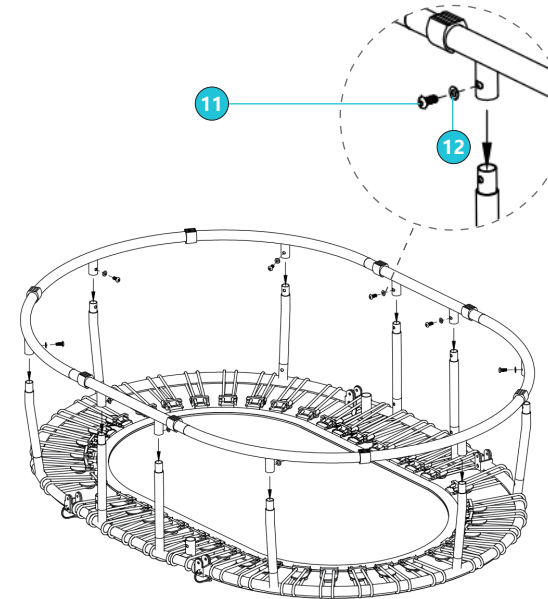

STEP 6

Turn over trampoline and place part 7 onto trampoline as shown in figure. Once one secure the Pad (part 7) with elastic rope to the frame of the trampoline.

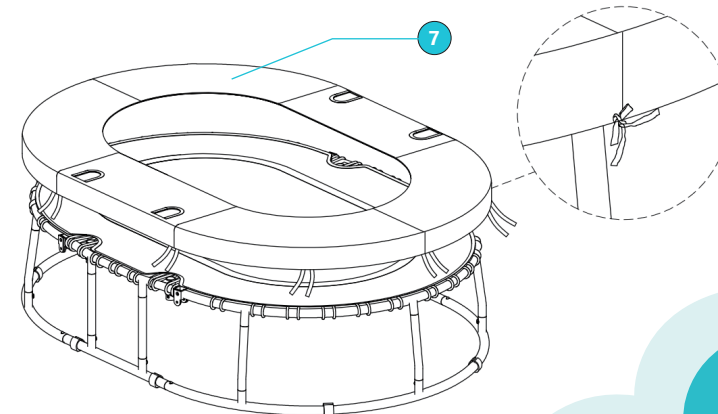

ASSEMBLY INSTRUCTIONS

PLEASE KEEP THIS MANUAL AS IT CONTAINS IMPORTANT INFORMATION

STEP 7

Connect Parts 8 and 9 as shown in figure. Once connected insert to open slots. To secure Parts 8 and 9 to trampoline use hexagon bolt (Part 11) and washer (Part 12) as shown in close up figure. Once screws are tightened your trampoline is ready for use.

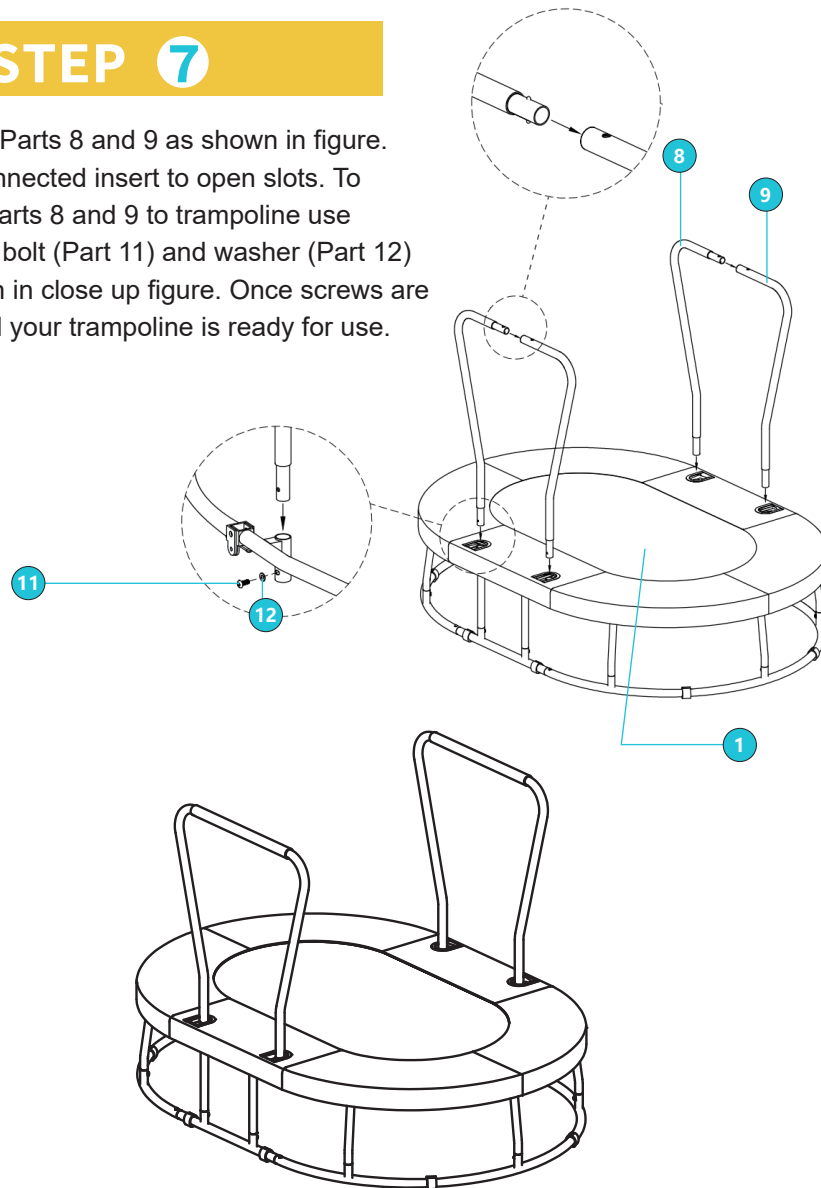

Installation completion drawing

⚠ IMPORTANT WARRANTY INFORMATION ⚠

For full warranty information on your SkyBound product please visit:
<https://www.skyboundusa.com/warranty>



SkyBoundUSA.com

(888) 891-4689

SkyBound Customer Service
help@skyboundusa.com

SkyBound, a BX International Inc Company.
SkyBound is a registered trademark of BX International Inc.
in the U.S. and other countries. All logos, names,
characters, likenesses, images, slogans and
packaging appearance are the property of SkyBound.