

Motor Controllers AC Variable Frequency Drives Type VariFlex³ RVLF



- AC variable speed drive for use with AC induction motors
- V/F control + Auto-torque compensation function
- Input voltage ranges: 1-ph 200~240V, 3-ph 380~480V
- 2 frame sizes
- Conforms to EMC standard EN 61800-3
- Parameter settings by keypad
- IP 20 models with power switch
- DIN-rail or panel mounting
- Built-in EMI filter
- Frequency 0.01~650.00Hz
- Integrated ModBus communication
- Communication interface modules for Profibus/DeviceNet/Ethernet (TCP/IP)/CANopen

Product Description

The RVLF is a simple and compact AC variable speed drive for use with 3-phase AC induction motors. The drives have compact dimensions and can be installed side by side to save space. The full range of products

covers all voltage ratings from the single phase 200VAC up to the three phase 480VAC. The RVLF uses state-of-the-art microprocessor technology which controls all drive functions.

Ordering Key

RVLF A 1 20 075 F

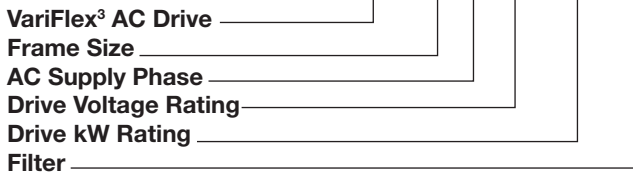

Approvals



Type Selection

Frame Size	AC Supply Phase	Drive Voltage Rating	Drive kW Rating	Filter
A: Size 1 B: Size 2	1: 1-Phase 3: 3-Phase	20: 200-240VAC 40: 380-480VAC	020: 0.20kW, 0.25HP	F: Built-in EMI filter
			040: 0.40kW, 0.50HP	
			075: 0.75kW, 1.0HP	
			150: 1.5kW, 2.0HP	
			220: 2.2kW, 3.0HP	

Selection Guide

Voltage Rating	AC Supply Phase	Motor Rating	Ordering Code
200 - 240VAC (+10% / -15%)	1-Phase	0.20kW 0.25HP	RVLFA120020F
		0.40kW 0.50HP	RVLFA120040F
		0.75kW 1.0HP	RVLFA120075F
		1.5kW 2.0HP	RVLFB120150F
		2.2kW 3.0HP	RVLFB120220F
		0.75kW 1.0HP	RVLFB340075F
380 - 480VAC (+10% / -15%)	3-Phase	1.5kW 2.0HP	RVLFB340150F
		2.2kW 3.0HP	RVLFB340220F

Input / Output Data

220V Class: Single phase

Model: RVLF	RVLFA120020F	RVLFA120040F	RVLFA120075F	RVLFB120150F	RVLFB120220F
Horse power rating	0.25HP	0.5HP	1HP	2HP	3HP
Nominal motor power	0.2kW	0.4kW	0.75kW	1.5kW	2.2kW
Rated output current	1.8A	2.6A	4.3A	7.5A	10.5A
Rated capacity	0.68kVA	1.00kVA	1.65kVA	2.90kVA	4.00kVA
Input voltage range	Single phase: 200~240VAC (+10% / -15%), 50/60HZ				
Output voltage range	Three phase 0~240VAC				
Input current	4.9A	7.2A	11A	15.5A	21A
Allowable momentary power loss time	1.0 s	1.0 s	1.0 s	2.0 s	2.0 s
Protection class	IP20				

400V Class: Three phase

Model: RVLF	RVLFB340075F	RVLFB340150F	RVLFB340220F
Horse power rating	1HP	2HP	3HP
Nominal motor power	0.75kW	1.5kW	2.2kW
Rated output current	4.3A	7.5A	10.5A
Rated capacity	1.65kVA	2.90kVA	4.00kVA
Input voltage range	Three phase: 380~480VAC (+10% / -15%), 50/60HZ		
Output voltage range	Three phase 0~480VAC		
Input current	6.4A	9.4A	12.2A
Allowable momentary power loss time	1.0 s	2.0 s	2.0 s
Protection class	IP20		

Environmental Data

Installation Location	Indoor (protected from corrosive gases and dust)	EMC Compliance	EN61800-3, first environment
Operating Temperature		LVD Compliance	EN50178
Size A without fan	-10 ~ +40°C	Electrical Safety	UL508C
Size B with fan	-10 ~ +50°C	Protection Level	IP20
Storage Temperature	-20~+60°C / -4°~+140° F	Altitude	Altitude of 1000m (3181ft) or below, below 5.9m/s ² (0.6G)
Humidity	Under 95%RH (no condensation)	Vibration	1.0G, in compliance with IEC 60028-2-6
Shock	Under 20Hz, 1G (9.8m/s ²); 20~50Hz 0.6G (5.88m/s ²)		

General Data

Control Mode	V/F Control + Auto-torque compensation function.	Main Features	Overload detection, 8 preset speeds, auto-run, ACC/DEC switch (2 stages), Main/Alt run command select, Main/Alt frequency command select, PID control, torque boost, V/F start frequency, fault reset, firemode.
Frequency	0.01~650.00Hz. Digital input: 0.01Hz. Analog input: 0.06Hz/60Hz	Display	7 segment display (LED)
Range	0.01~650.00Hz.	LED status Indicator	Parameter/parameter value/frequency/line speed/DC voltage/output voltage/output current/PID feedback/input and output terminal status/heat sink temperature/program version/fault log. For run/stop/forward and reverse.
Settings resolution	Digital input: 0.01Hz.		
Settings	Analog input: 0.06Hz/60Hz <ul style="list-style-type: none"> Keypad: Set directly with ▲▼ keys or the VR (potentiometer) on the keypad. External input terminals AVI (0/2~10V) ACI (0/4~20mA) input 		
Analog voltage input	multifunction input up/down function (Group3). Frequency set by communication module.	Protective Functions	Overload protection
Analog current input	Lower and upper frequency limits 3 skip-frequency settings.	Overload protection	Integrated motor and inverter overload protection. Over 410VAC. Under 190VAC.
Frequency limit		Over voltage	Under 190VAC.
Run		Under voltage	Inverter auto-restart after a momentary power loss.
Operational settings	<ul style="list-style-type: none"> Keypad run, stop button. External terminals: multi-operation-mode 2/3 wire selection jog operation. Run signal, using a communication module. 	Momentary power loss restart	Stall prevention for acceleration/deceleration/and continuous run.
Drive Functions		Stall prevention	Electronic circuit protection. Electronic circuit protection. Heatsink over temperature protection, auto carrier frequency reduction with temperature rise, fault output, reverse prohibit, number of auto restart attempts, parameter lock.
V/F curve setting	6 fixed curves, 1 programmable.	Short-circuit output terminal	RS485 (Modbus) built in, with one-to-one or one-to-many control.
Carrier frequency	1~16KHz (default 5KHz).	Grounding fault	
Acceleration and deceleration control	2 off ACC/DEC time parameters. 4 off S curve parameters.	Additional protective functions	
Multifunction input	19 functions (refer to manual group3).	Communication	
Multifunction digital output	14 functions (refer to manual group3).		
Multifunction analog output	5 functions (refer to manual group3).		

Protection Functions

Over Current	Inverter rated current 150%/1min	Instantaneous Power Loss Restart	Quick restart if a momentary power loss occurs.
Over Voltage	200V class: < 410VAC, 400V class: < 820VAC	Stall Prevention	ACC/DEC/continuous running stall prevention.
Under Voltage	200V class: < 190VAC, 400V class: < 380VAC		

Connection Diagrams

Model:

200V: RVLFA120020F/RVLFA120040F/RVLFA120075F/RVLFB120150F/RVLFB120220F

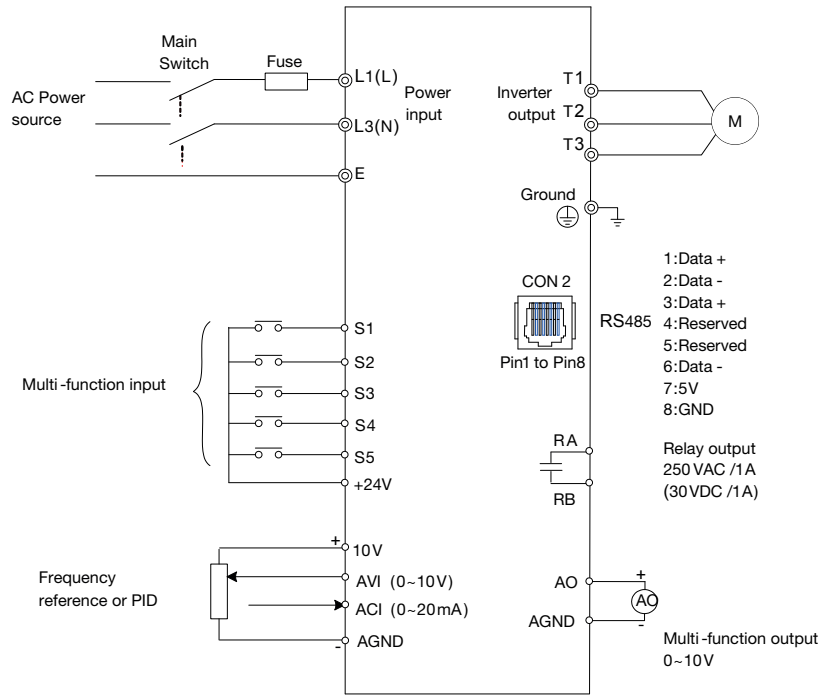

Model:

400V: RVLFB340075F/RVLFB340150F/RVLFB340220F

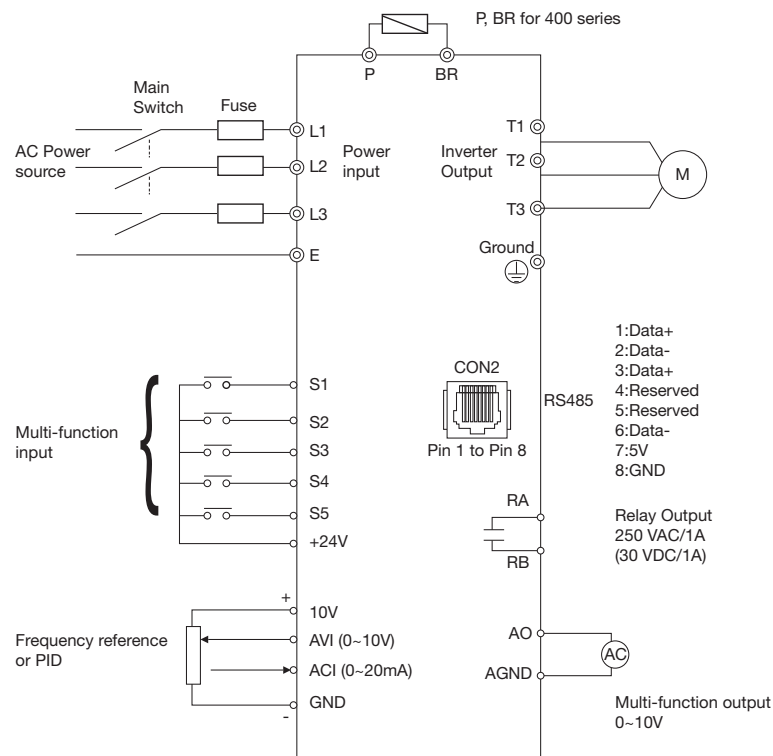

Terminal Description

Terminal symbols	TM1 Function description
L1(L)	Main power input, L1 (L)/L2/L3 (N)
L2	
L3 (N)	
P*	Externally connected braking resistor
BR*	
T1	Inverter output, connect to U, V, W terminals of motor
T2	
T3	
	Ground terminal

Single phase

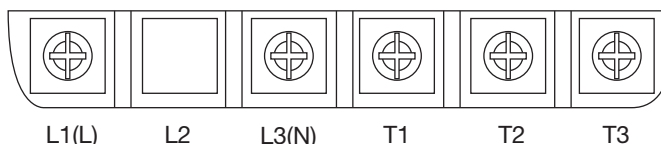

Note: the screw on L2 terminal is removed for the single phase input supply models

Three phase (400V series)

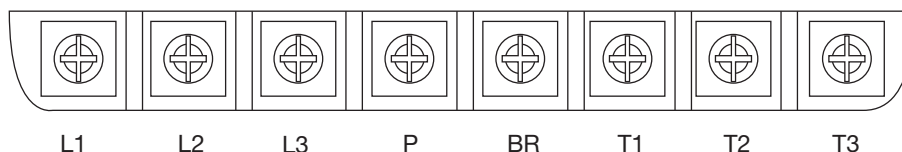

Terminal Description

Terminal symbols	TM2 Function description
RA	Relay output terminal, specification: 250VAC/1A (30VDC/1A)
RB	
+24V	S1~S5 (COMMON) [PNP]
S1	Multi-function input terminals (refer to group3)
S2	
S3	
S4	
S5	
10V	Built in power for an external speed potentiometer
AVI	Analog voltage input, specification: 0~10 / 2~10VDC
ACI	Analog current input, specification: 0~20 / 4~20mA
AO	Multi function analog output terminal, maximum output 10VDC/1mA
AGND	Analog ground terminal

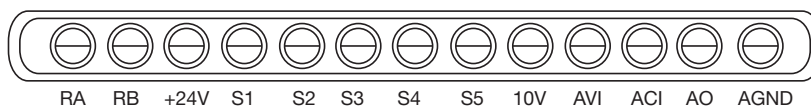

Connection specification:

Model	TM1					TM2				
	Cable Size		Tightening torque			Cable Size		Tightening torque		
	AWG	mm ²	kgf.cm	lbf.in	Nm	AWG	mm ²	kgf.cm	lbf.in	Nm
Frame 1	22~10	0.34~6	14	12.15	1.37	24~12	0.25~4	4.08	3.54	0.4
Frame 2			12.24	10.62	1.2					

Dimensions (mm/inches)

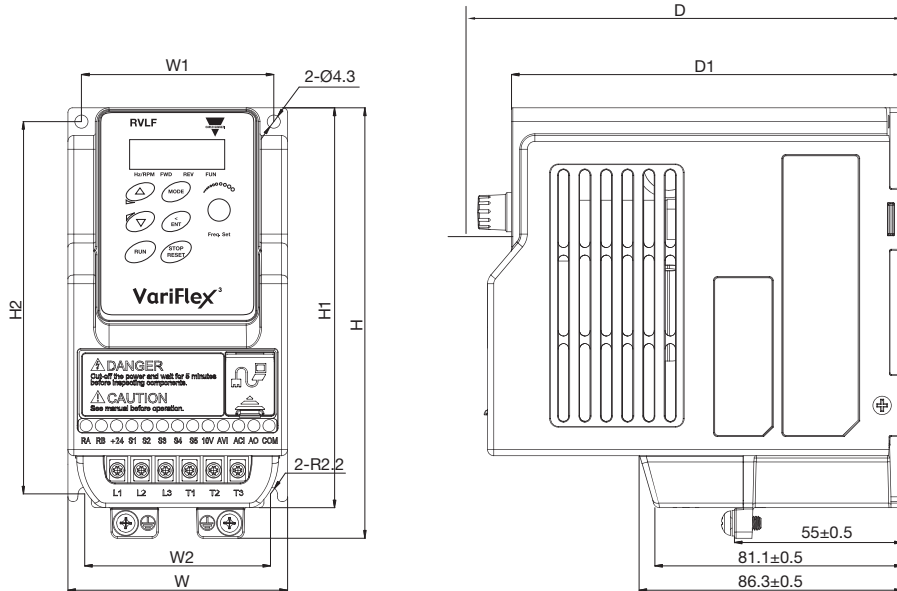

Model	W	W1	W2	H	H1	H2	D	D1	Weight kg (lbs)
RVLFA120020F	72 (2.83)	63 (2.48)	61 (2.40)	141 (5.55)	131 (5.16)	122 (4.80)	139.2 (5.48)	136 (5.35)	0.9 (1.98)
RVLFA120040F	72 (2.83)	63 (2.48)	61 (2.40)	141 (5.55)	131 (5.16)	122 (4.80)	139.2 (5.48)	136 (5.35)	0.9 (1.98)
RVLFA120075F	72 (2.83)	63 (2.48)	61 (2.40)	141 (5.55)	131 (5.16)	122 (4.80)	139.2 (5.48)	136 (5.35)	0.9 (1.98)

Dimensions (mm/inches)

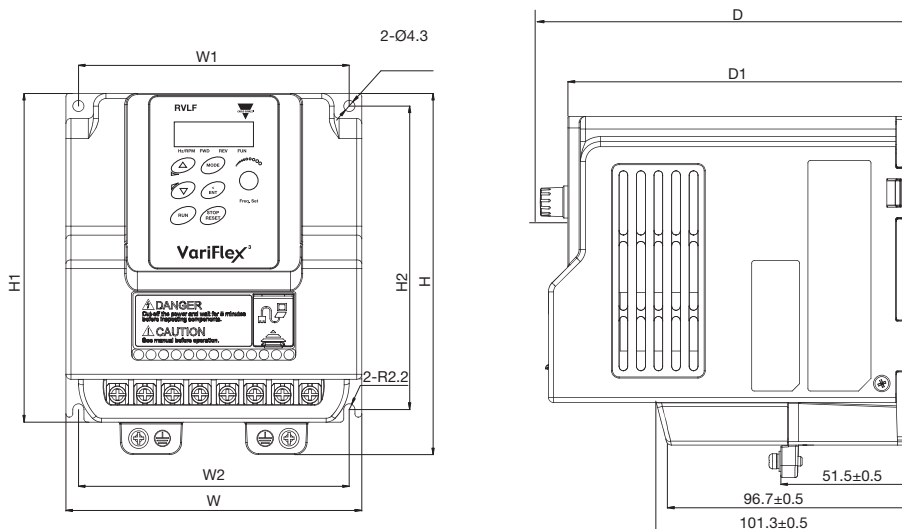

Model	W	W1	W2	H	H1	H2	D	D1	Weight kg (lbs)
RVLFB120150F	118 (4.65)	108 (4.25)	108 (4.25)	144 (5.67)	131 (5.16)	121 (4.76)	147.3 (5.80)	144.2 (5.68)	1.6 (3.52)
RVLFB120220F	118 (4.65)	108 (4.25)	108 (4.25)	144 (5.67)	131 (5.16)	121 (4.76)	147.3 (5.80)	144.2 (5.68)	1.6 (3.52)
RVLFB340075F	118 (4.65)	108 (4.25)	108 (4.25)	144 (5.67)	131 (5.16)	121 (4.76)	147.3 (5.80)	144.2 (5.68)	1.6 (3.52)
RVLFB340150F	118 (4.65)	108 (4.25)	108 (4.25)	144 (5.67)	131 (5.16)	121 (4.76)	147.3 (5.80)	144.2 (5.68)	1.6 (3.52)
RVLFB340220F	118 (4.65)	108 (4.25)	108 (4.25)	144 (5.67)	131 (5.16)	121 (4.76)	147.3 (5.80)	144.2 (5.68)	1.6 (3.52)

Installation Space

Sufficient air circulation space for cooling should be provided, as shown in examples below.
(We recommend that the drive is installed on a dissipative surface).

Single unit installation

In order to ensure optimal cooling the transducer should be installed vertically.

Frames A & B.

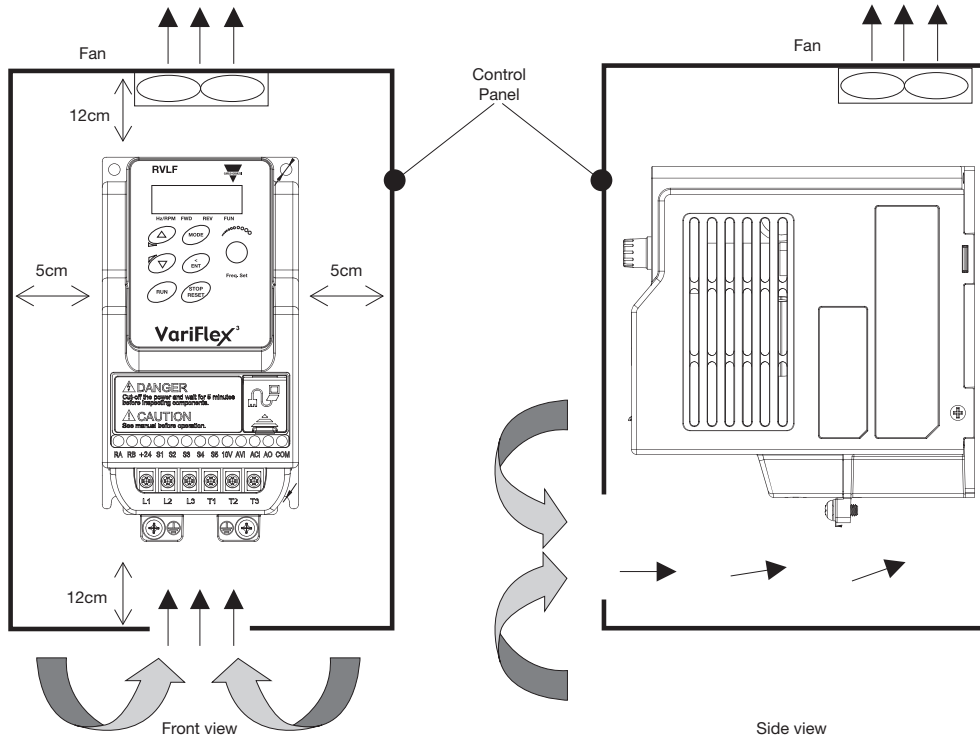

Side by side installation

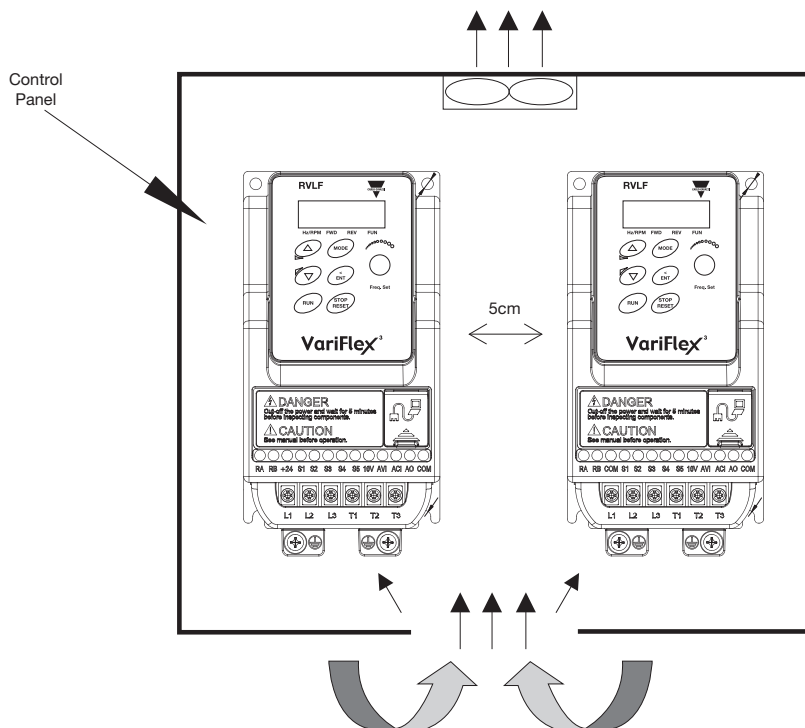

The necessary physical space and cooling should be provided, based on the ambient temperature and the heat loss in the panel.

Environment

Installation site

Install in an environment that will not have an adverse effect on the operation of the unit and ensure that there is no exposure to the following:

- Direct sunlight, rain or moisture.
- Oil, mist or salt.
- Dust, lint fibres, small metal filings or corrosive liquids or gas.
- Electromagnetic interference from sources such as welding equipment.
- Radioactive or flammable materials.
- Excessive vibration from machines such as stamping or punching machines.
 (Add vibration-proof pads if necessary).

Accessories	Model	Function	Notes
Keypad Extension cable	RV-CAB01	Keypad extension cable	1m
	RV-CAB02		2m
	RV-CAB03		3m
	RV-CAB05		5m
Copy module	RV-CU	Copy module	
Communication modules	RV-PDP	Connection of Profibus-DP	For RVLf series
	RV-TCPIP	Connection TCP-IP	
	RV-DNET	Connection DeviceNet	
	RV-CAN	Connection CANopen	
USB cable	RV-USB	USB cable	1.8m
	RV-USB3		3m
DIN Rail	RVLf-DIN01	DIN clip for RVLfA	
	RVLf-DIN02	DIN clip for RVLfB	