

# HANG IT PERFECT

FIRST TIME • EVERY TIME

1. CROSSBAR WITH RULER (IN. & CM)
2. ARM WITH RULER (IN. & CM)
3. KNOB
4. HOOK & PIN
5. LEVEL (ON BACKSIDE OF TOOL)

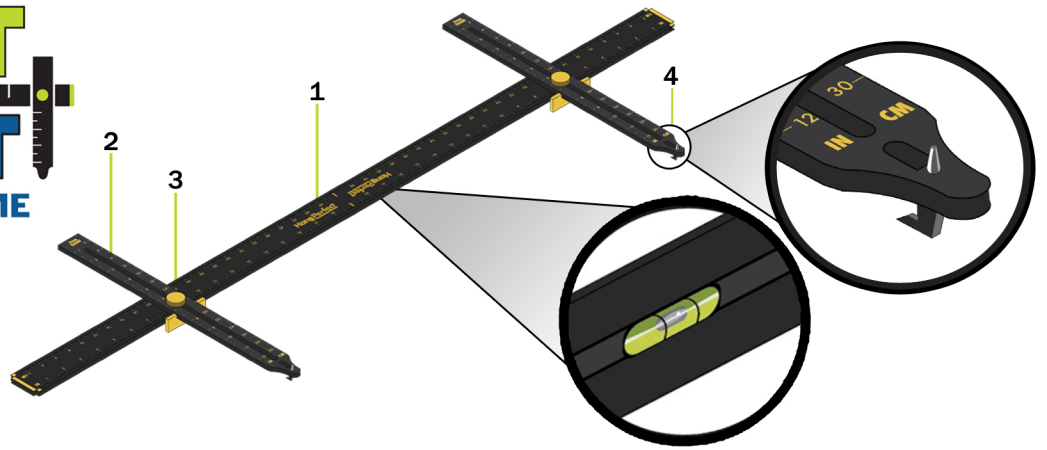

## GETTING STARTED

A. These instructions are for a frame with a wire hanging mount.

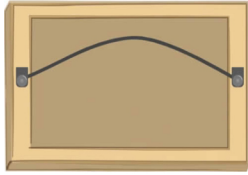

B. Decide where on the wall to hang the frame. With a pencil, mark on the wall where you want the top & center of the frame to be.

C. Determine the center of the frame and mark it with a pencil.

## STEP 1. ALIGN

NOTE: For a wire hanging mount, the frame is more secure if either 2 nails or hangers are installed. These instructions accommodate for that.

- A. Place frame face down on a flat surface.
- B. Position the crossbar against the top of the frame.

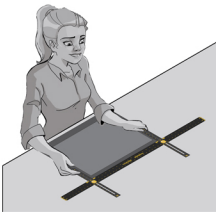

- C. Align the center mark of the crossbar with the center of the frame.
- D. Slide arms together, meeting at the crossbar and frame's center mark.
- E. Slide arms up until hooks catch wire.
- F. Tighten knobs to secure in place.

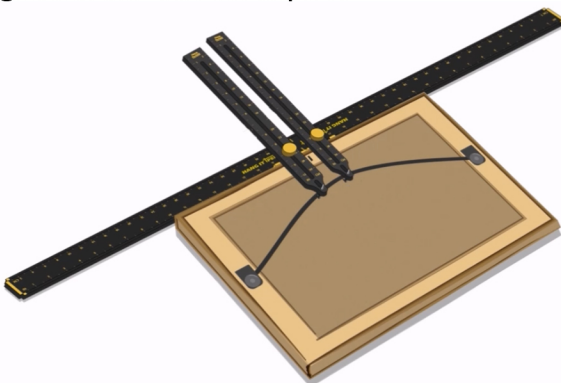

## STEP 2. LEVEL

A. Remove Hang It Perfect from frame.

B. Place Hang It Perfect with knobs against the wall and level facing you.

C. Align the center of the level with the top-center mark you made on the wall from step one.

D. Use the level to make sure the crossbar is straight.

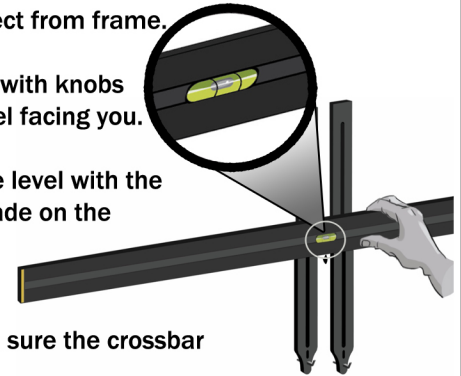

## STEP 3. MARK

A. Firmly press the hook so that the pin creates a dimple on the wall.

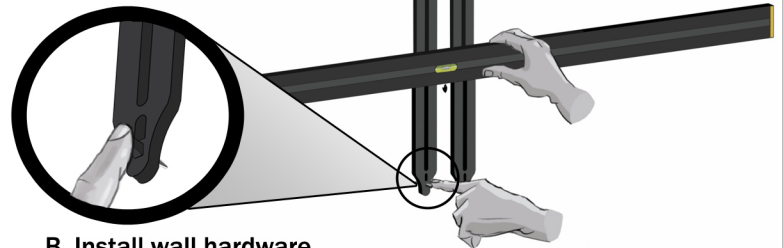

B. Install wall hardware.

### NAILS

install nail directly into dimple mark

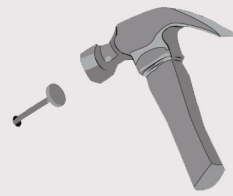

### HANGERS

place hanger base atop dimple mark and install

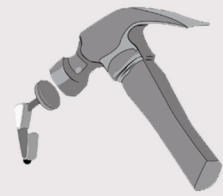

## STEP 4. HANG

A. Hang the frame on the installed wall hardware and enjoy!

