

# HANG IT PERFECT

FIRST TIME • EVERY TIME

1. CROSSBAR WITH RULER (IN. & CM)
2. ARM WITH RULER (IN. & CM)
3. KNOB
4. HOOK & PIN
5. LEVEL (ON BACKSIDE OF TOOL)

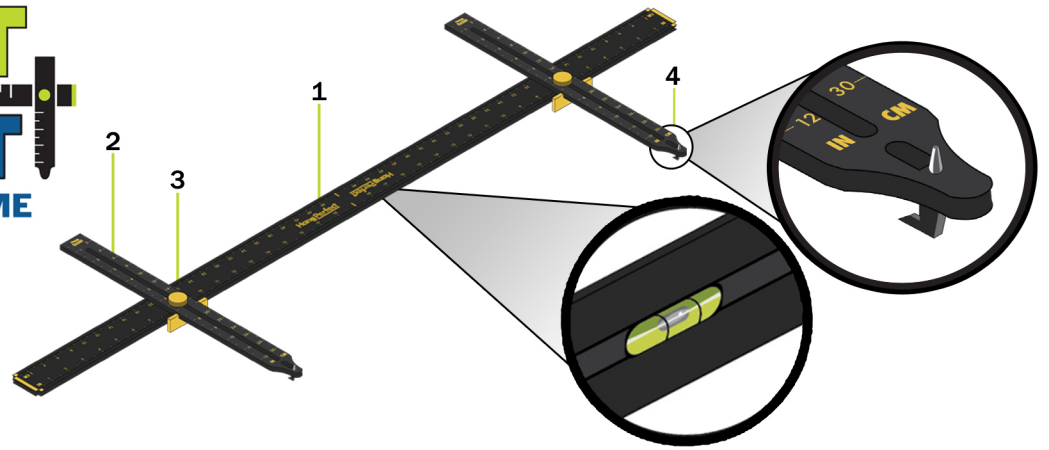

## GETTING STARTED

A. These instructions are for a frame with a single hanging mount.

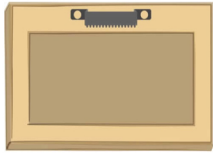

B. Decide where on the wall to hang the frame. With a pencil, mark on the wall where you want the top & center of the frame to be.

C. Determine the center of the frame and mark it with a pencil.

## STEP 1. ALIGN

A. Place frame face down on a flat surface.

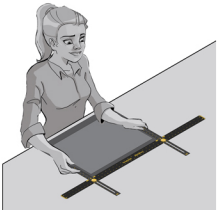

B. Position the crossbar against the top of the frame.

C. Align the center mark of the crossbar with the center of the frame.

D. For a single hanging mount, only 1 arm will be needed.

E. Slide the right arm to the end of crossbar and secure in place.

F. Slide the left arm to align with the center mark.

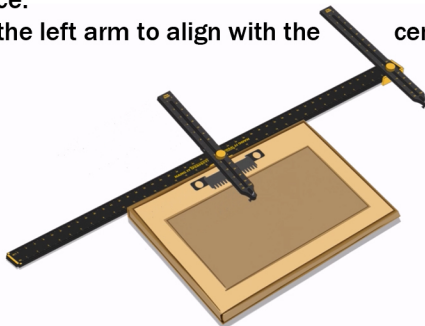

G. Slide arm up until hook catches hardware.

H. Tighten knob to secure arm in place.

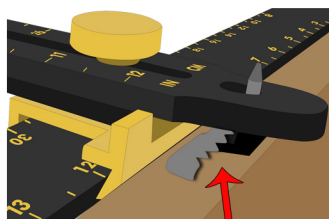

## STEP 2. LEVEL

A. Remove Hang It Perfect from frame.

B. Place Hang It Perfect with knobs against the wall and level facing you.

C. Align the center of the level with the top-center mark you made on the wall from step one.

D. Use the level to make sure the crossbar is straight.

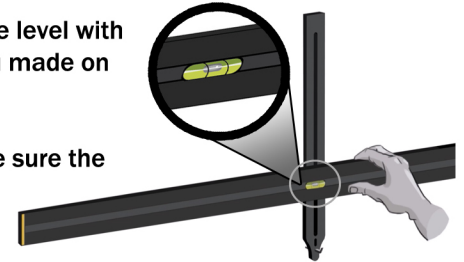

## STEP 3. MARK

A. Firmly press the hook so that the pin creates a dimple on the wall.

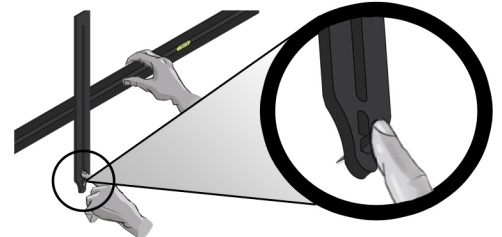

B. Install wall hardware.

### NAILS

install nail directly into dimple mark

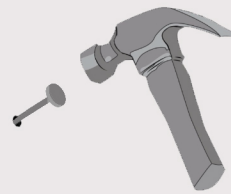

### HANGERS

place hanger base atop dimple mark and install

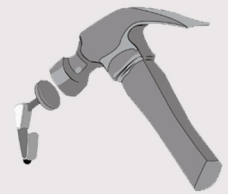

## STEP 4. HANG

A. Hang the frame on the installed wall hardware and enjoy!

