

HOW TO HANG A SHELF WITH A BRACKET

GETTING STARTED

- A. Follow the installation instructions and recommendations provided by the shelf manufacturer.
- B. With a pencil, mark on the wall where you want the top and center of the shelf to be.

STEP 1

- A. Place bracket on a flat surface and identify it's center.
- B. Position the crossbar against the top of the bracket.
- C. Align the center mark of the crossbar with the center of the bracket.

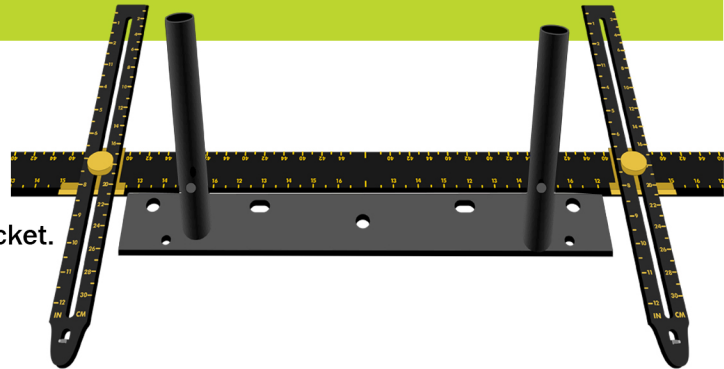

STEP 2

- A. Align arms with the bracket holes that will be used for the screws. You are able to see the alignment through the viewing window on the H.I.P arm.

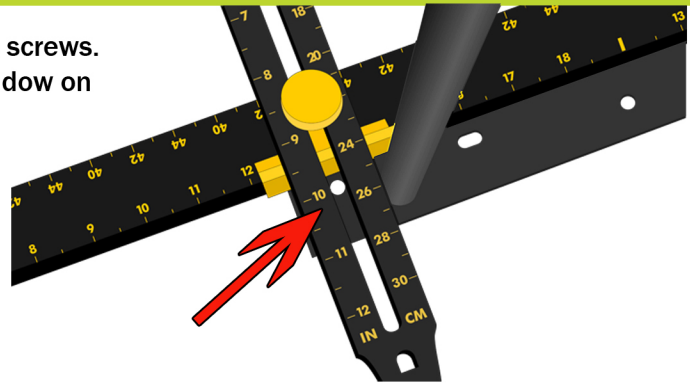

- B. Slide arms up till hook aligns overtop the bracket holes.

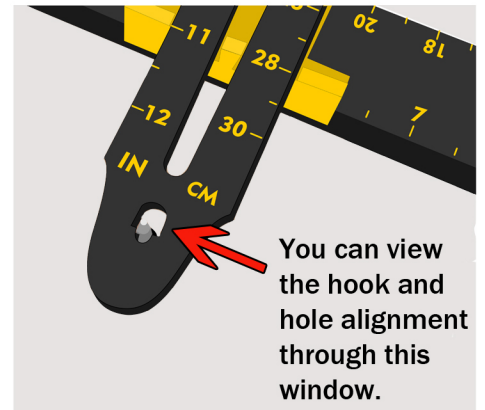
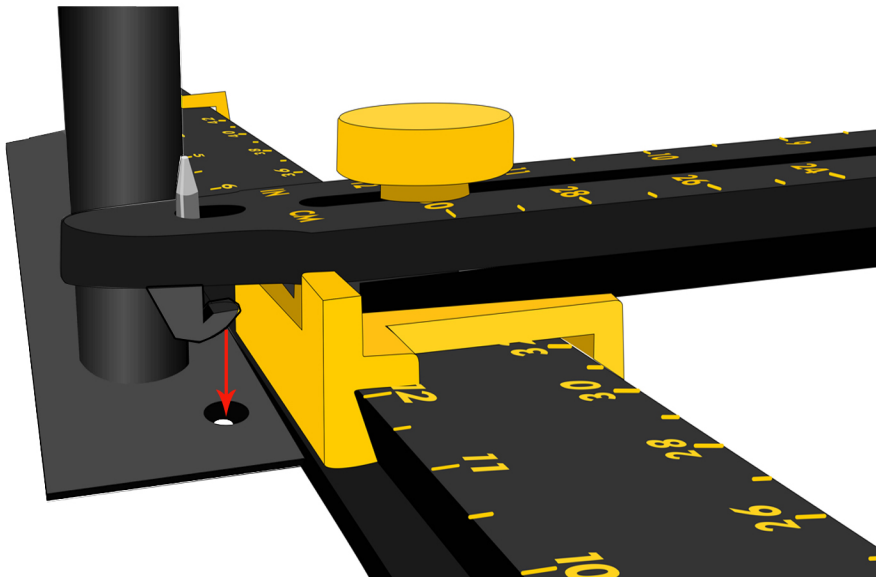

- C. Tighten knobs to secure arms in place.

STEP 3

- A. Remove Hang It Perfect from bracket.
- B. Place Hang It Perfect with knobs against the wall and level facing you.
- C. Align the center of the level with the mark you made on the wall from step one.
- D. Use the level to make sure the crossbar is straight.
- E. Firmly press hooks to create dimple marks on the wall.

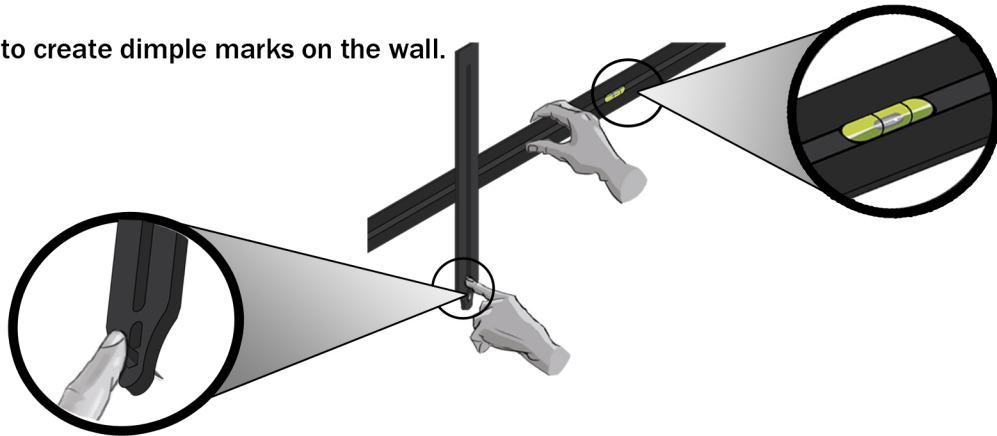

STEP 4

- A. Remove Hang It Perfect from wall.
- B. Follow the shelf's manufacturer recommendations regarding the type of wall hardware to use. If needed, install wall anchors into the dimple marks on wall.
- C. Place bracket against the wall. Align the bracket holes to the dimple marks on wall or the installed wall anchors.

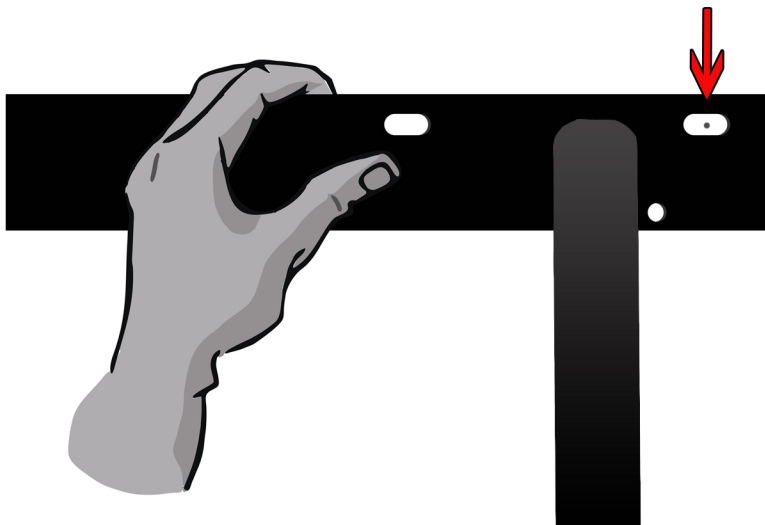

STEP 5

- A. Install the screws.
- B. Mount the shelf and enjoy!