

Safety. First.

Test Procedures & Battery Handling

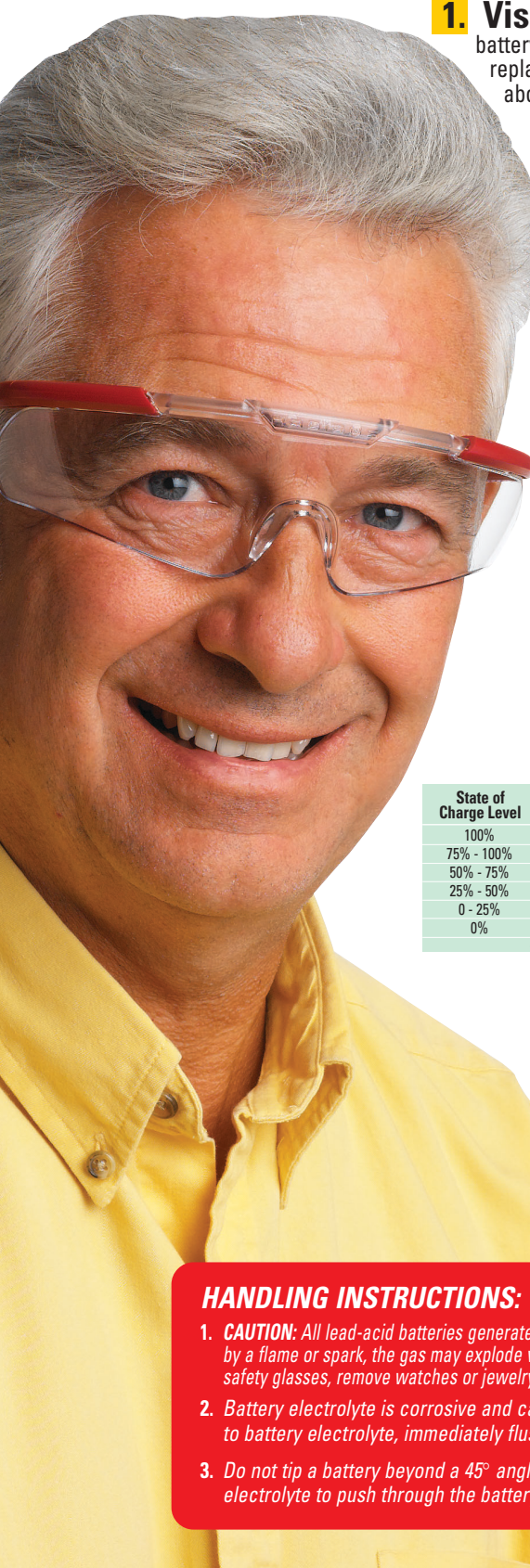

1. Visual Inspection: Check battery age or length of service if available. Inspect battery for damage – when physical damage to the battery container or terminals is present, replace the battery. If none, check the battery's cell electrolyte levels. Fluid levels should be above the top of plates in all cells, and no higher than the top of the fluid level indicator:

If the battery is sufficiently filled with electrolyte – proceed to step 2. If the top of the battery's plates are not covered with liquid, add water, replace vent caps and place the battery on charge. Be sure no open flame or spark is near while the battery's vent caps are removed from the battery.

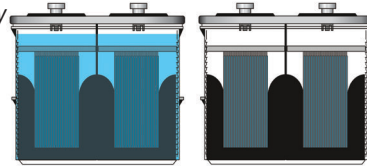

2. Specific Gravity Inspection:

Hydrometer reading of all cells should be at least 1.225 and show less than 50 points difference between high and low.

More than 50 points difference: replace the battery. Less than 50 points, but some cells read less than 1.225: recharge the battery. Replace the vent caps during recharge.

Charge the battery using a rate less than 50-amperes, until all cells measure a specific gravity of 1.265 to 1.275. If charging won't bring up specific gravity, replace the battery.

Example:	Hydrometer Float	State of Charge Level	Specific Gravity
CELL 6 - 1.200		100%	1.265 or Greater
CELL 6 - 1.210		75%	1.225 - 1.235
CELL 2 - 1.215		50%	1.190 - 1.200
CELL 1 - 1.240		25%	1.150 - 1.175
CELL 3 - 1.240		Discharged	1.125 or Less
CELL 4 - 1.255			

3. Open Circuit Voltage and Electrical Load Test:

Battery open circuit voltage is an effective indication of battery state of charge. Determine the approximate state of charge from the chart below.

State of Charge Level	12 Volt Battery Open Circuit Voltage	6 Volt Battery Open Circuit Voltage
100%	12.6 or Greater	6.3 or Greater
75% - 100%	12.4 - 12.6	6.2 - 6.3
50% - 75%	12.2 - 12.4	6.1 - 6.2
25% - 50%	12.0 - 12.2	6.0 - 6.1
0 - 25%	11.7 - 12.0	5.95 - 6.0
0%	11.7 or Less	5.95 or Less

Chart Assumes a Fully Charged Specific Gravity of 1.265.

Ambient Temperature	15-Second Minimum Voltage
70°F / 21°C and Above	9.5 Volts
50°F / 10°C and Above	9.4 Volts
30°F / -1°C and Above	9.1 Volts
15°F / -9°C and Above	8.7 Volts
0°F / -18°C and Above	8.5 Volts
Below 0°F / -18°C	8.0 Volts

Batteries with less than 75% state of charge should be charged before an electrical load test is applied to the battery.

When load testing batteries, remove all battery cables, disconnecting the negative cables first. Make sure the battery terminals are free of corrosion or dirt.

For heavy-duty batteries with threaded stud terminals, attach a lead charging post to the threaded stud terminal before testing. Using a carbon pile load tester or heavy duty adjustable load tester, apply a load test equivalent to 50% of the battery CCA Rating (0°F / -18°C) for 15 seconds; remove the load. Refer to the chart at the left to determine the minimum passing voltage.

*If the test voltage is above the minimum, return the battery to service.
If test voltage is below the minimum, replace the battery.*



HANDLING INSTRUCTIONS:

- CAUTION:** All lead-acid batteries generate hydrogen gas, which is highly flammable. If ignited by a flame or spark, the gas may explode violently. When working near batteries, always wear safety glasses, remove watches or jewelry, and avoid causing sparks with tools.
- Battery electrolyte is corrosive and can cause blindness or severe burns. If exposed to battery electrolyte, immediately flush with water and seek medical attention.
- Do not tip a battery beyond a 45° angle in any direction. This would allow battery electrolyte to push through the battery vent assembly.

The Power Behind Performance



Made in the USA

Battery Care...Maintenance

Battery Inventory Management

Batteries should be stored in a cool, dry area in an upright position. Store batteries on a solid surface that can safely accommodate their weight. Batteries can be safely stacked two or three layers high by using a secure stacking surface (wafer-board, plywood, etc.) placed between each layer. When stacking batteries in layers, take care to secure battery terminals against short-circuit and to block-and-brace batteries that prevents any movement of the battery group.

Use or sell oldest battery inventory first (*First In, First Out*). Batteries require periodic stock rotation and service charging to ensure peak performance. Batteries marked with Shipping Date Codes older than 6 months from the current date should be service charged before sale or use. Shipping Date Codes follow a universal code standard. For example, L5 = Battery shipped in December 2005:

Month		Year	
A – January	G – July	1 – 2001	6 – 2006
B – February	H – August	2 – 2002	7 – 2007
C – March	I – September	3 – 2003	8 – 2008
D – April	J – October	4 – 2004	9 – 2009
E – May	K – November	5 – 2005	0 – 2010
F – June	L – December		

Recommended Charging Practices

- Before charging service, refer to the charger manufacturer's instructions for correct charger-to-battery connection and equipment operation.
- Power off the charger before connection to the battery to avoid sparking.
- For batteries fitted with threaded stud terminals or GM-type side terminals, use only lead charging posts that ensure a flush lead-to-lead terminal surface contact. Verify that charging posts are securely tightened to the terminal, which will enable safe and effective charging service.
- To avoid battery explosion, never charge a frozen battery. Frozen batteries should be warmed to room temperature before charging service begins.
- Check battery cell electrolyte levels to ensure that liquid levels are above the top of the plates in all cells. If plates are not covered, add only enough water to cover plates, replace vent caps and place on charge. Be sure no open flame or spark is near while the battery's vent caps are exposed. After charging, fill with water and replace vent caps on the battery.
- Charging service should be terminated if batteries become excessively hot or if violent gassing or discharge of electrolyte occurs during charge.
- Avoid "quick" or "fast" charging batteries in all cases. Limit charger input current to 25% of the batteries reserve capacity minutes rating. Lower current input charges the battery more uniformly and creates less heat, which reduces the possibility of overcharge. Remember: overcharging ruins batteries.
- Monitor battery state-of-charge throughout the charging period, continuing the charge until a three-hour period shows no additional voltage or tapering of charge current. Refer to page 1 for full-charge voltage and specific gravity points.

Recommended Jump-Starting Practices

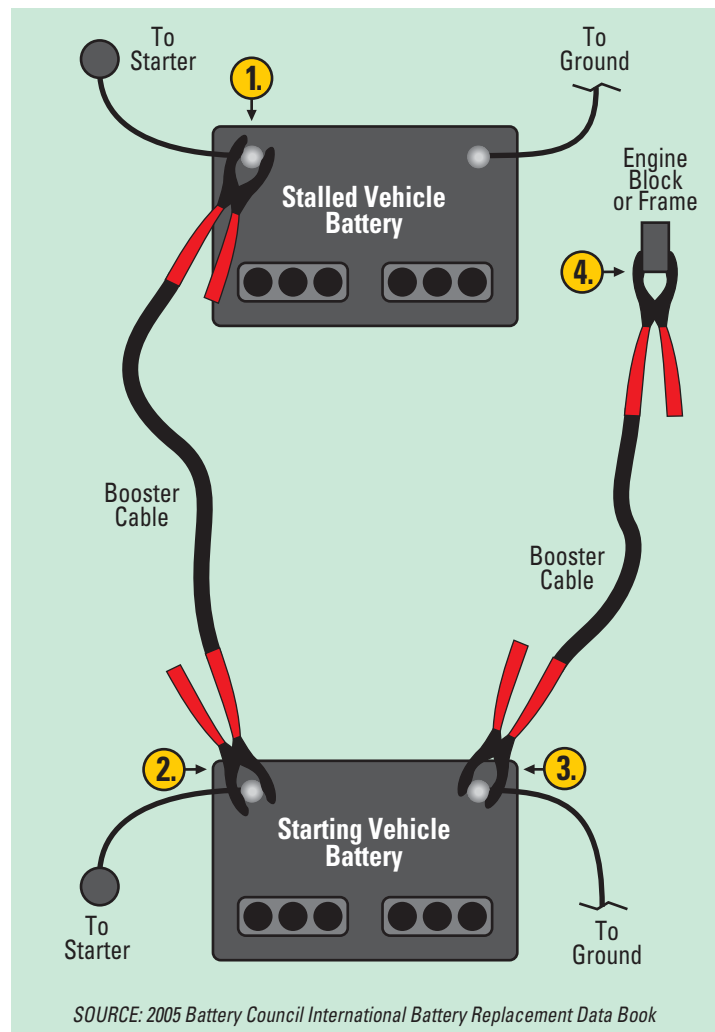

Refer to the vehicle owner's manual for manufacturer's recommended procedure.

Make it a point to wear personal protective equipment whenever jump-starting batteries – shield your eyes and face at all times, wear heavy-duty protective gloves before touching batteries or jumper cables.

Make certain that battery vent caps are tight and level. Place a heavy cloth over both batteries' vent caps. Keep a safe distance between vehicles involved in jump-starting, making sure vehicles don't come into contact while jump-starting occurs.

1. Connect one end of the booster cable to the positive terminal of the discharged battery.
2. Connect the other end of the positive booster cable to the positive terminal of the assisting battery.
3. Connect one end of the negative booster cable to the negative terminal of the assisting battery.
4. Complete the jump-start connection by securing the other end of the negative booster cable to the engine block of the vehicle having the discharged battery – as far away from the discharged battery as possible. Be aware of safety risks while completing this connection – moving fan blades, belts and fuel lines.