

TWO

UNITS

Depth 20

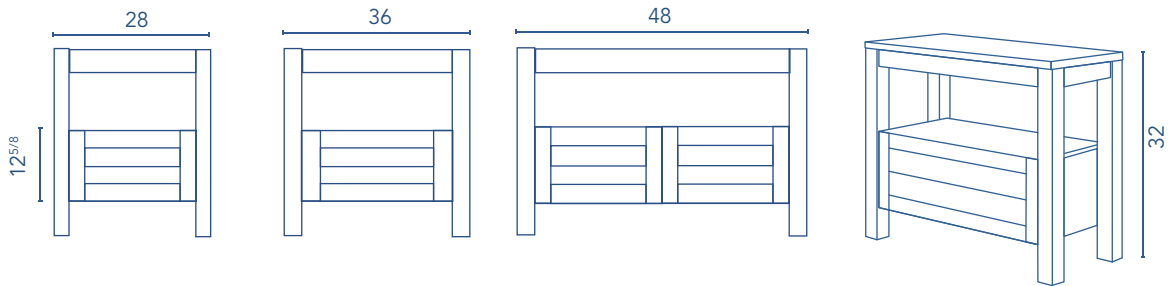

TECHNICAL INFORMATION

STRUCTURE:	Wood veneer.
FRONT	Wood veneer 3/4 in.
HANDLE:	Integrated in the front of the furniture.
DRAWERS:	Soft close system with partial extraction runners. Textile drawers.
ALL HANGING BRACKET:	Hidden hanging bracket for hidden installation with great resistance.
LEGS:	Integrated legs.
PIPE DEPTH:	Space behind drawer is 3 in.

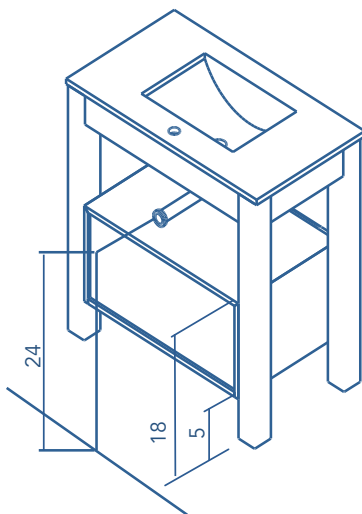

FINISHES

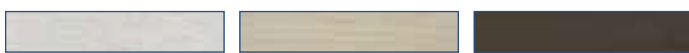

WHITE

NATURAL

OAK

Finishes may vary