



# DIAMONDBACK

DiamondBackCovers.com / 800 935 4002



# INSTALLATION GUIDE

CVR-1

**45 minutes**  
Normal install time

Keep an eye out for these icons:

**IMPORTANT!**  
Important installation information

**Helpful Hints**  
Tips to assist installation

## PARTS INCLUDED:

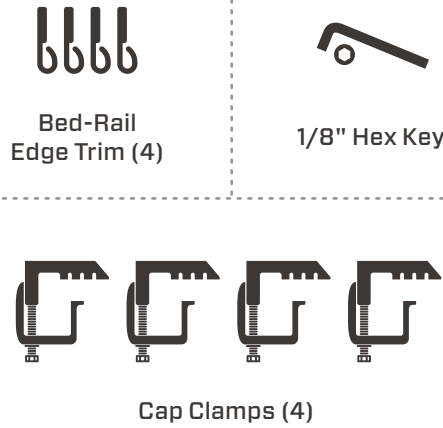
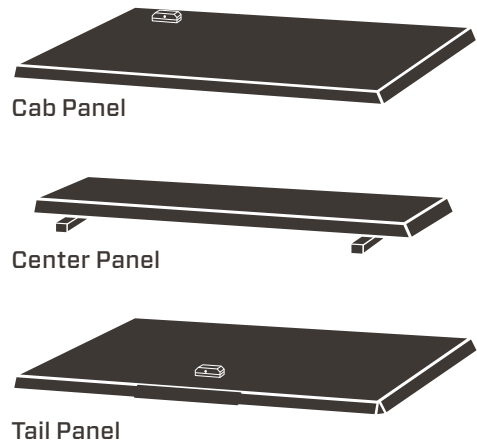

## TOOLS REQUIRED:



## PRE-INSTALLATION NOTES:

If you're installing a **cab guard** or **headache rack**, mount it prior to mounting the cover. Refer to its installation guide for details.

If you have a '19-up Ford **Ranger**, affix the included bulkhead weatherstrip first. Refer to its separate installation guide for details.

If you have a **Tundra**, put the bed rail cap shims on first. Refer to their separate installation guide for details.

## MOUNT THE PANELS

**1** Place the **center panel** across the center of the bed, cheated slightly toward the tailgate.

**!** Since the cover is slightly tapered, make sure the arrow sticker on the underside of the center panel is pointing toward the tailgate.

**2** Loosely affix the center panel to the truck by finger-tightening a **cap clamp** at each of the four interior corners of the underside of the center panel.

**3** Attach the **tail panel** by angling it 90° from the bed rails, sliding its driver-side, loop-shaped hinge knuckle fully onto the corresponding center-panel hinge pin, then dropping its passenger-side, C-shaped hinge knuckle fully onto its corresponding pin.

**4** Lower the tail panel into the closed position.

**!** To avoid hinge damage, make sure the drop-on hinge is fully mated before beginning to close the panel.

**5** Repeat steps 3-4 for the **cab panel**, starting this time with the loop-shaped hinge knuckle on the passenger side.

**6** Position the cover front to back so that the leading edge of the closed cab panel lines up with the outside edge of the center of the bulkhead.

**7** Center the cover side to side on the truck.

**8** Tighten the cap clamps with a 9/16" socket.

**!** Road vibration can loosen your clamps. Retighten them after 100 miles. Check them every time you haul on top.

## PREP FOR THE LOCK RODS

- 9** If a DiamondBack HD, unpin each of the four lock-rod guide-bracket slide plates by using a 7/16" socket to move one of its bolts to the second, unoccupied slot.
- 10** If plastic extends beyond the bottom of the vertical face of the metal bed rails, trim a two-inch length of it flush with the bed rail's bottom edge at each of the four points where a lock rod will pass under the rails.
- 11** Peel the red adhesive backing from the edge trim pieces. Affix them to the metal bed rail (most trucks) or the bottom edge of the plastic bed rail cap (Jeep Gladiators) at the four points where a rod will pass underneath, the bottom curl of their 'j's touching the rail or caps' bottom edge.
- ★ Step 11 is unnecessary on '20-up Silverado & Sierra 2500 & 3500s and all '07-13 Silverados and Sierras.
- ★ You may need to pull the plastic bed rail cap away from the metal bed rail to provide enough clearance to get the edge trim on.
- ★ Using a tool to widen the curl of the 'j' can make this step easier.

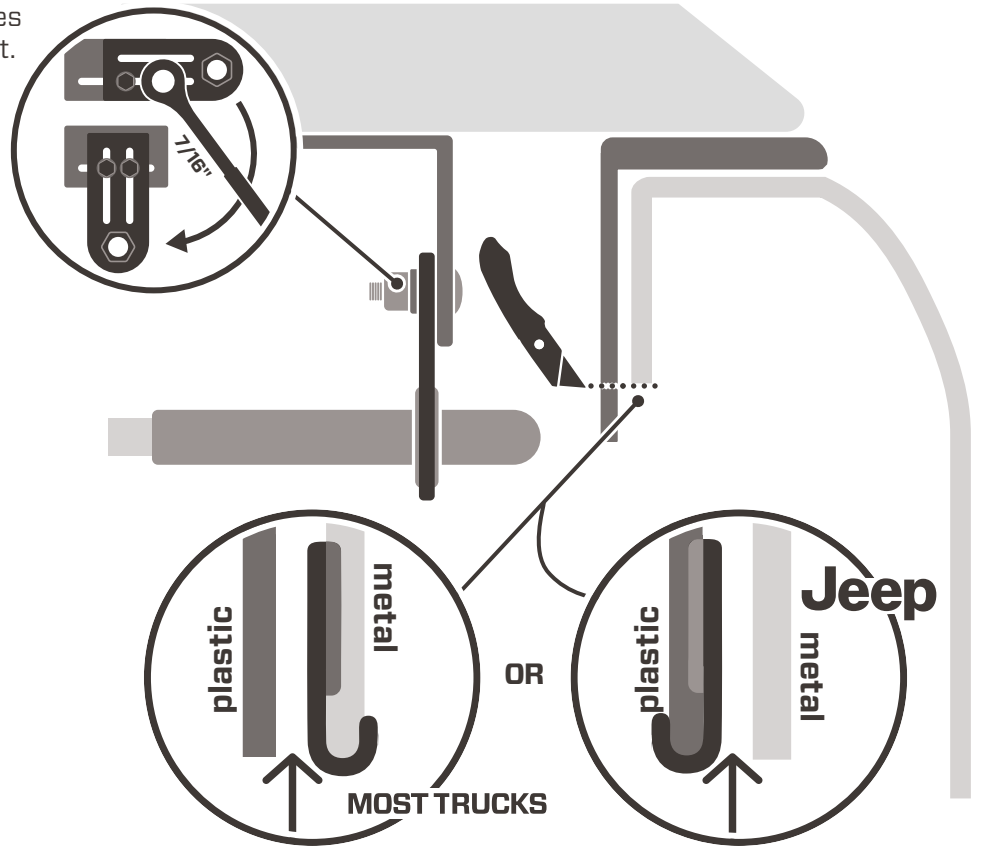

## ADJUST THE LOCK RODS

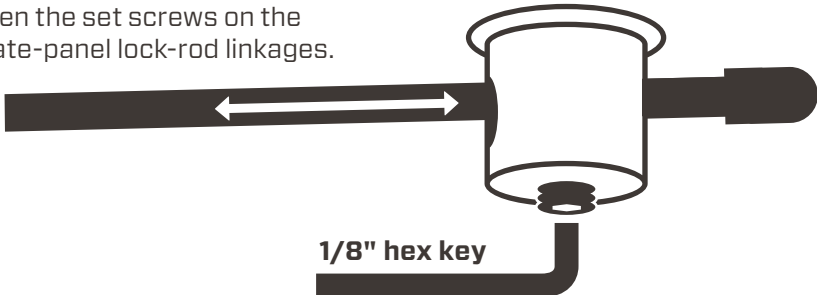
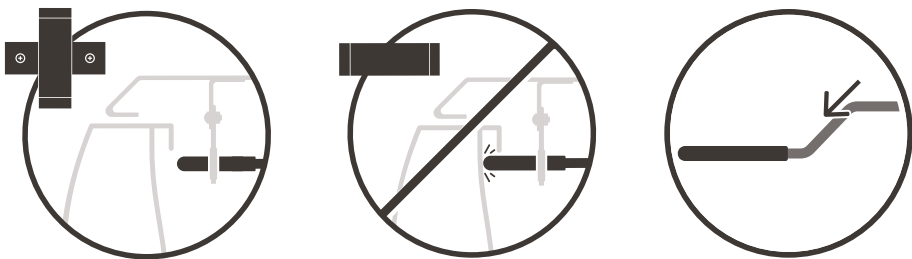
- 12** Loosen the set screws on the tailgate-panel lock-rod linkages.
- 
- 13** Adjust the lock rods and retighten their set screws so that
- with the lock handle in the open position, the rod tips clear the bed rails,
  - with the handle in the closed position, the rod tips do not strike the bed walls, and
  - the first bend in the rods points downward.
- 

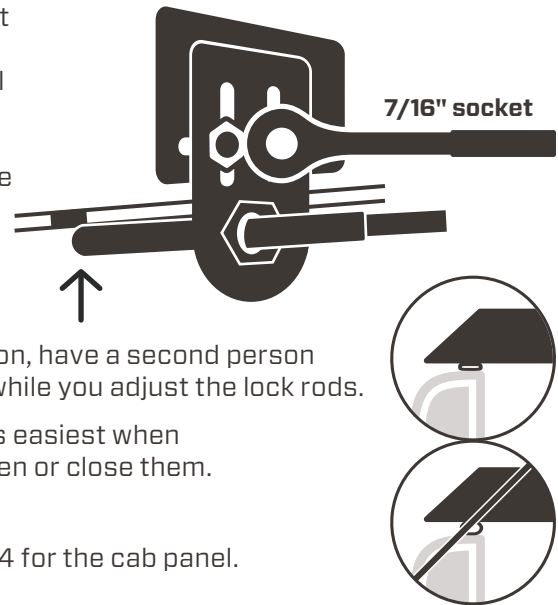
- 14** Position the lock rods tight against the underside of the bed rails so that they'll draw the panels down and compress the weatherstrip. Tighten the rod guide brackets with a 7/16" socket.
- 
- ! For best weather protection, have a second person press down on the cover while you adjust the lock rods.
- ★ Using the access panels is easiest when you press down as you open or close them.
- 15** Repeat steps 12 through 14 for the cab panel.
- ★ Your panels should be hard to operate at first. After finishing install below, leave the panels closed as much as possible for 3-4 days to break in the weatherstrip. After that period, you should find that the panels open and close without difficulty.
- ★ If you are also installing a **Cross Bin**, do so now. Refer to the **Cross Bin Installation Guide** for details.

## ATTACH THE SAFETY CATCH & GAS SPRINGS

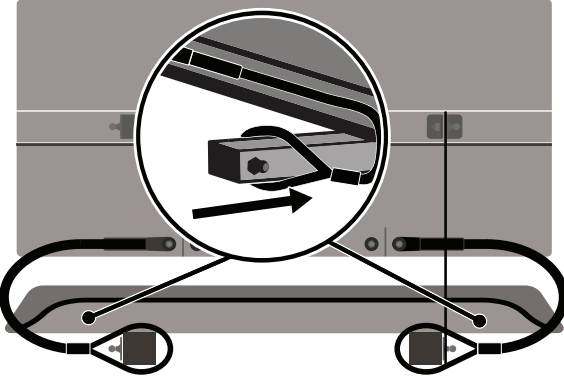
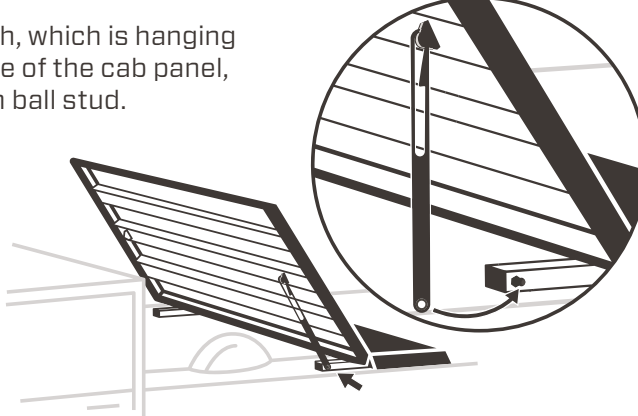
- 16** Open the cab panel. Have a second person support it in the open position.
- 17** Slip the looped ends of the cable tethers that are attached to the underside of the cab panel around the center-panel ball stud arms, well past the ball studs.
- 
- 18** Fit the safety catch, which is hanging from the driver side of the cab panel, around the bottom ball stud.
- 

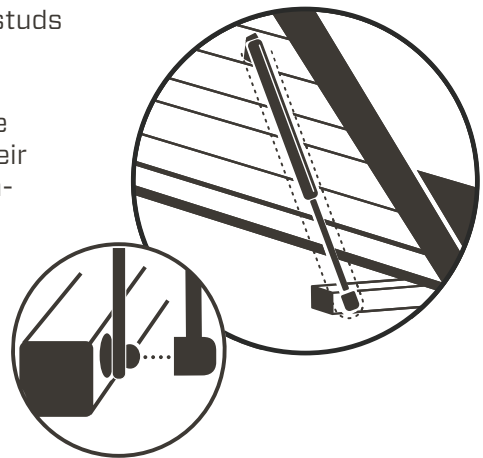
- 19** Attach a **gas spring** to the ball studs alongside the safety catch.
- ★ If some of your gas springs have heavier poundage printed on their sides than others, use the stronger ones on the cab panel.
- ! To avoid premature failure of your gas springs, attach them barrel up, shaft down.
- 
- 20** Attach the three remaining gas springs (barrel up, shaft down).
- 21** If your truck has bed rail caps, affix the included **bulkhead weatherstrip** if you haven't already. Refer to the **Bulkhead Prep Kit Installation Guide** for details.
- 22** Leave the cover closed and locked for 24 hours to allow the weatherstrip adhesive, which is pressure-sensitive, to fully cure.
- 24 hours**  
Adhesive cure time