



# DIAMONDBACK

DiamondBackCovers.com / 800 935 4002

'07-up Tundra, '05-up Tacoma w/73" bed,  
'04-up Titan, '05-up Frontier & '20-up Gladiator  
w/Deck Rail System or Utili-track



# INSTALLATION GUIDE

CVR-2

**45 minutes**  
Normal install time

Keep an eye out for these icons:

**IMPORTANT!**  
Important installation information

**Helpful Hints**  
Tips to assist installation

## PARTS INCLUDED:



Cab Panel



Center Panel

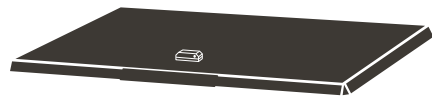

Tailgate Panel



1/8" Hex Key



Bed-Rail Edge  
Trim (4)  
(Frontiers only)

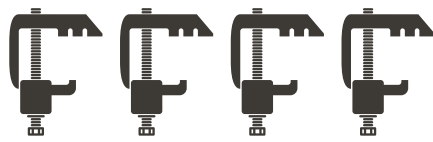

Cap Clamps (4)



Gas  
Springs (4)

## TOOLS REQUIRED:



Ratchet Wrench



9/16" Socket



Utility Knife



7/16" Socket

## PRE-INSTALLATION NOTES:

If you are installing a **cab guard** or **headache rack**, you should mount it prior to mounting your DiamondBack cover. Refer to its installation guide for details.

It's possible for one person to install a DiamondBack solo, but the whole process, especially positioning the panels and adjusting the lock rods, is much easier with two people.

## MOUNT THE PANELS

**1** Place the **center panel** across the center of bed, cheated slightly toward the tailgate.

**!** Make the sure the arrow sticker on the underside of the center panel is pointing toward the tailgate.

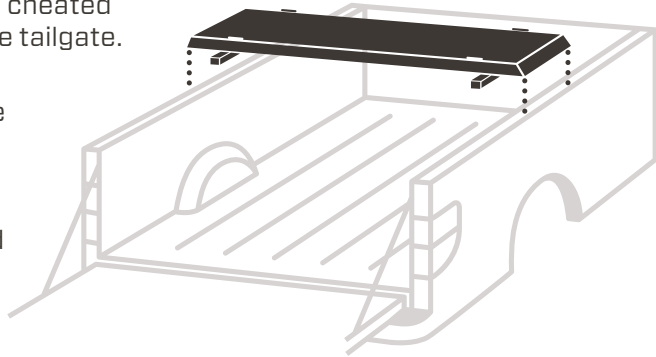

**2** Attach the **tail panel** by angling it 90° from the bed rails, sliding its driver-side, loop-shaped hinge knuckle fully onto the corresponding center-panel hinge pin, then dropping its passenger-side, C-shaped hinge knuckle fully onto its corresponding pin.

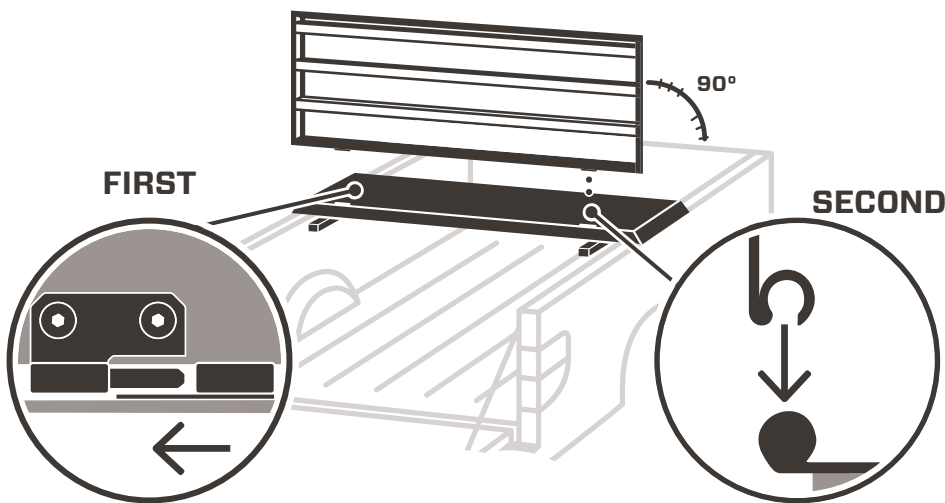

**!** To avoid hinge damage, make sure the C-shaped hinge knuckle is fully engaged with its pin before tilting the panel.

**3** Lower the tail panel into the closed position.

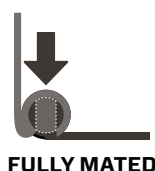

**4** Repeat steps 2-3 for the **cab panel**, starting this time with the loop-shaped hinge knuckle on the passenger side.

**5** Position the cover front to back so that the leading edge of the closed cab panel lines up with the outside edge of the center of the bulkhead.

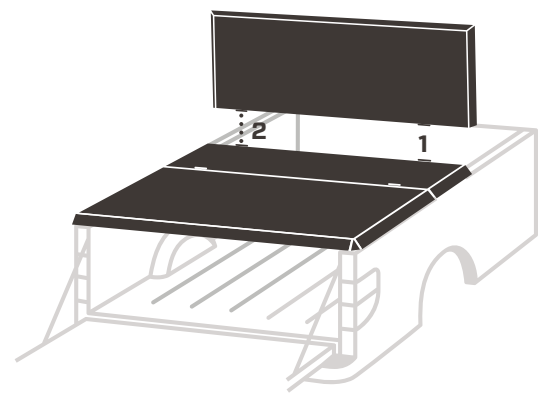

**6** Center the cover side to side on the truck.

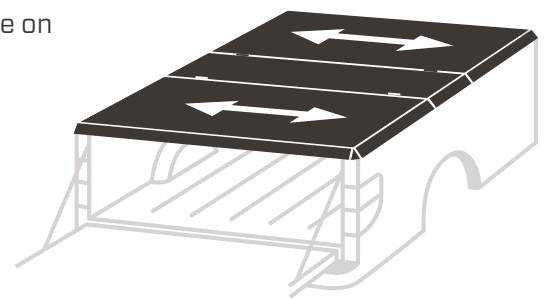

**7** Affix the center panel to the truck by placing a **cap clamp** at each of the four interior corners of the underside of the center panel and tightening them with a 9/16" socket.

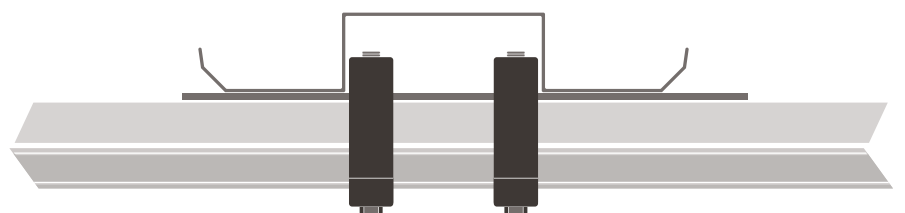

**!** The bottom halves of the cap clamps should be in the Utili-track or deck rail system.

**!** On Toyotas, don't tighten the clamps so much that they deform the plastic bed rail caps.

**!** Road vibration can loosen your clamps. Retighten them after 100 miles. Check them every time you haul on top.

CONTINUED ON REVERSE >

## ADJUST THE LOCK RODS

**8** If a DiamondBack HD, unpin each of the four lock-rod guide-bracket slide plates by using a 7/16" socket to move one of its bolts to the second, unoccupied slot.

**9** If a Gladiator, Tundra, Tacoma, or Titan, skip to step 11. If a Frontier, then if plastic extends beyond the bottom of the vertical face of the metal bed rails, trim a two-inch length of it flush with the bed rail's bottom edge at each of the four points where a lock rod will pass under the rails.

**10** Peel the red adhesive backing from the **edge trim pieces**. Affix them to the metal bed rail at the four points where a rod will pass underneath, the bottom curl of their 'j's touching the bottom edge of the rail.

**!** Affix the edge trim to the painted metal only, *behind* the plastic bed liner or bed rail cap.

**★** You may need to pull the plastic bed rail cap away from the metal bed rail to provide enough clearance to get the edge trim on.

**★** Using a tool to widen the curl of the 'j' can make this step easier.

**11** Loosen the set screws on the tailgate-panel lock-rod linkages.

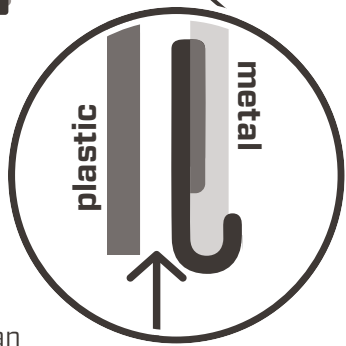
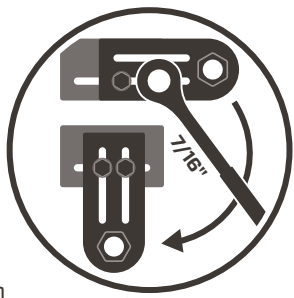
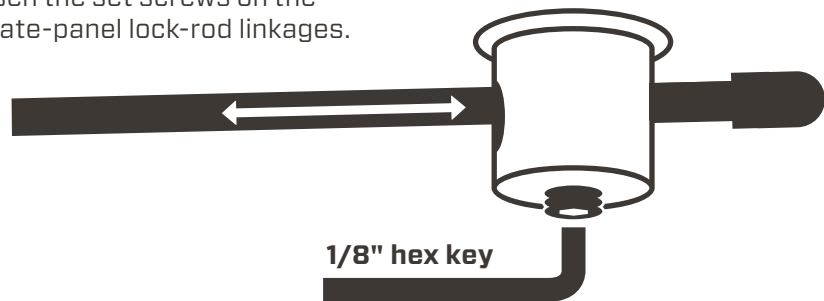

**12** Adjust the lock rods and retighten their set screws so that

- with the lock handle in the open position, the rod tips stop about 1/4" short of the bed rail (Frontier), Trail Rail (Gladiator), Utili-track (Titan), or deck rail system (Tundra & Tacoma),
- with the handle in the closed position, the rod tips do not strike the bed walls, and
- the first bend in the rods points downward.

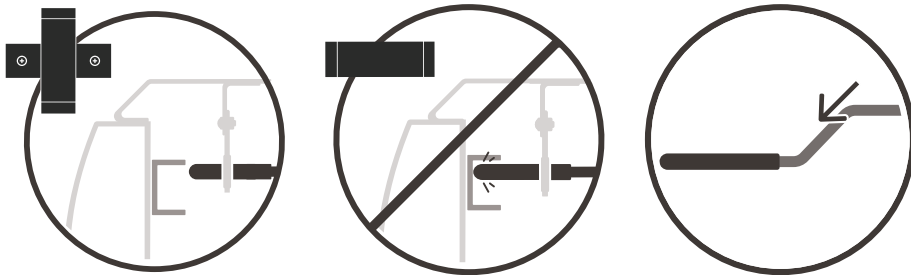

**13** With the lock handle in the closed position, set the lock rods tight against:

- the underside of the bed rails on Frontiers and
- the inside of the deck rail, Trail Rail, or Utili-track on other trucks.

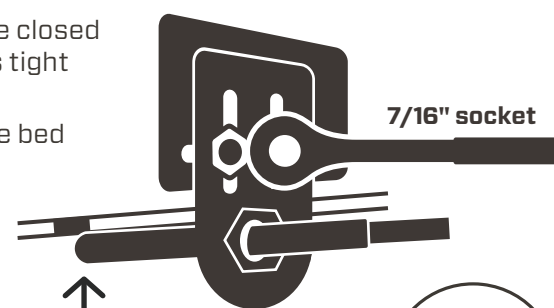

Tighten the rod guide brackets with a 7/16" socket.

**!** For best weather protection, have a second person press down on the cover while you adjust the lock rods.

**★** Using the access panels is easiest when you press down as you open or close them.



**14** Repeat steps 11 through 13 for the cab panel.

**★** Your panels should be hard to operate at first. After finishing install below, leave the panels closed as much as possible for 3-4 days to break in the weatherstrip. After that period, you should find that the panels open and close without difficulty.

**★** If you are also installing a **Cross Bin**, do so now. Refer to the **Cross Bin Installation Guide** for details.

## ATTACH THE SAFETY CATCH & GAS SPRINGS

**15** Fit the safety catch, which is hanging from the driver side of the cab panel, around the bottom ball stud.

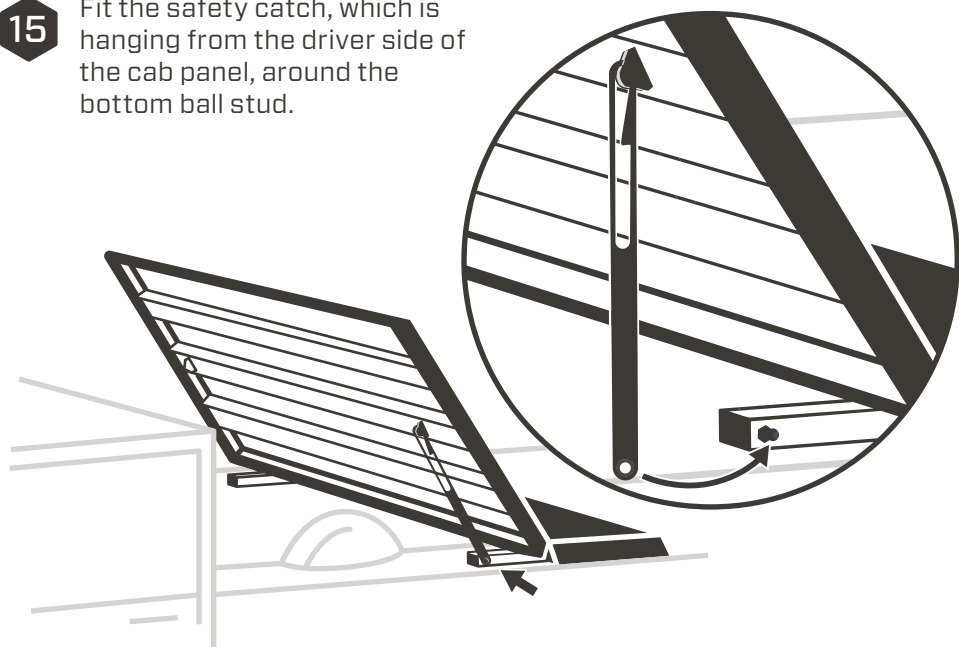

**16** Attach a **gas spring** to the ball studs alongside the safety catch.

**★** If some of your gas springs have heavier poundage printed on their sides than others, use the stronger ones on the cab panel.

**!** To avoid premature failure of your gas springs, attach them barrel up, shaft down.

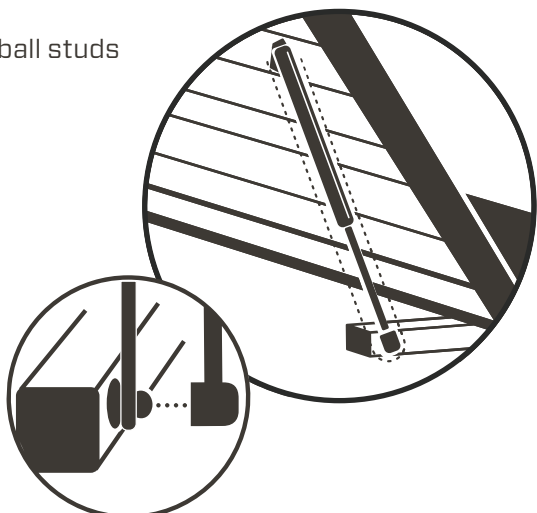

**17** Attach the three remaining gas springs (barrel up, shaft down).

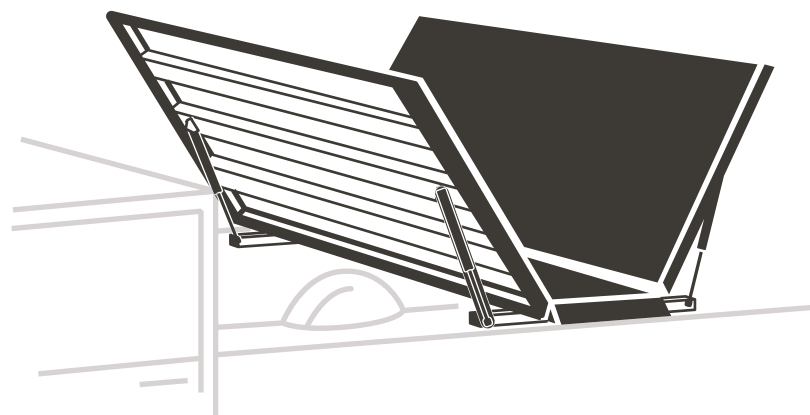

**18** If your truck has bed rail caps, affix the included **bulkhead weatherstrip**. Refer to the **Bulkhead Prep Kit Installation Guide** for details.

**19** Leave the cover closed and locked for 24 hours to allow the weatherstrip adhesive, which is pressure-sensitive, to fully cure.

**24 hours**  
Adhesive cure time