



DIAMONDBACK

DiamondBackCovers.com / 800 935 4002

'05-up Toyota Tacoma
with the 60" Cargo Bed



INSTALLATION GUIDE

CVR-4

75 minutes
Normal install time

Keep an eye out for these icons:

IMPORTANT!
Important installation information

Helpful Hints
Tips to assist installation

PARTS INCLUDED:



Cab Panel



Center Panel



Tail Panel



Lock-Rod Striker Brackets (2)

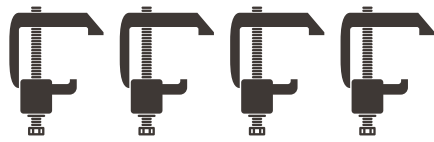

Cap Clamps (4)



1/8" Hex Key



Gas Springs (4)

TOOLS REQUIRED:



Ratchet Wrench



9/16" Socket



T30 Torx/Star Wrench



7/16" Socket

PRE-INSTALLATION NOTES:

If you are installing a **cab guard** or **headache rack**, you should mount it prior to mounting your DiamondBack cover. Refer to its installation guide for details.

If you have a '16-up Tacoma, affix the included gasket to the bulkhead. Refer to the **Bulkhead Prep Kit Installation Guide** for details.

It's possible for one person to install a DiamondBack solo, but the whole process, especially positioning the panels and adjusting the lock rods, is much easier with two people.

PREPARE THE CARGO BED & ATTACH THE COVER

1 Remove the plastic cap from the tailgate end of the driver-side deck rail by pressing its tab.

2 Use a T30 Torx wrench to remove the factory bolt near the tailgate end of the deck rail.

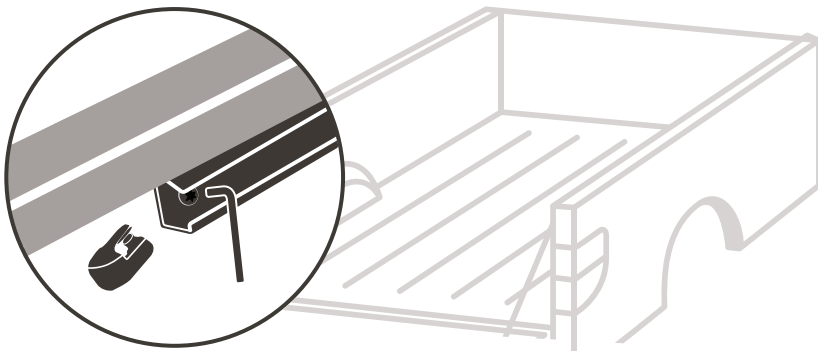

3 Slide the driver-side **lock-rod striker bracket** into the deck rail until its forward hole aligns with the factory bolt.

4 Reinsert the factory bolt and retighten it with the Torx wrench.

5 Repeat steps 1-4 on the passenger side.

6 Place the **center panel** across the center of bed, cheated slightly toward the tailgate.

Since the cover is slightly tapered, make sure the arrow sticker on the underside of the center panel faces the tailgate.

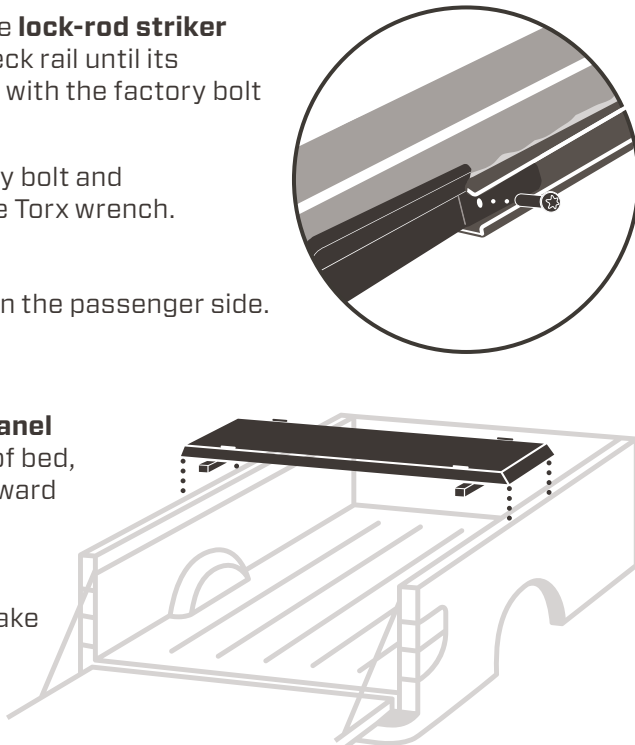

7 Attach the **tail panel** by angling it 90° from the bed rails, sliding its driver-side, loop-shaped hinge knuckle fully onto the corresponding center-panel hinge pin, then dropping its passenger-side, C-shaped hinge knuckle fully onto its corresponding pin.

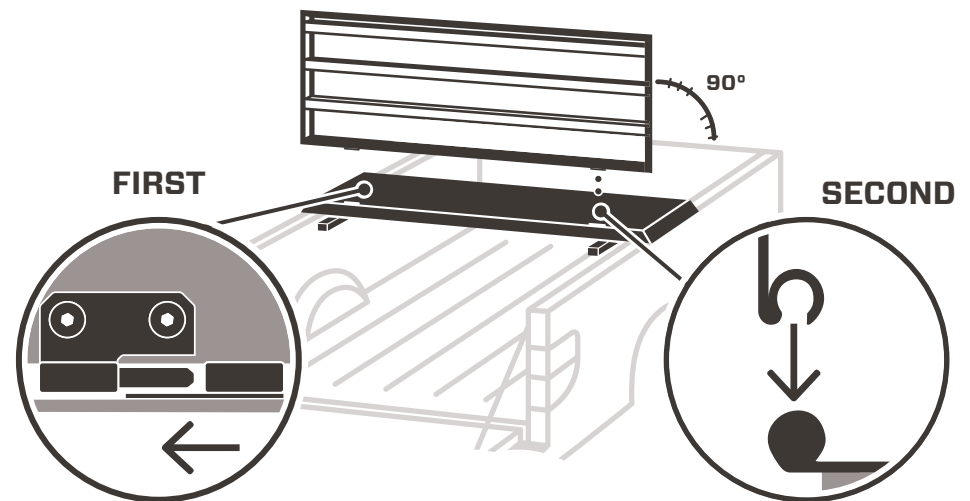

To avoid hinge damage, make sure the C-shaped hinge knuckle is fully engaged with its pin before tilting the panel.

8 Lower the tail panel into the closed position.

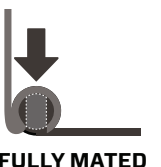

9 Repeat steps 7-8 for the **cab panel**, starting this time with the loop-shaped hinge knuckle on the passenger side.

10 Position the cover front to back so that the leading edge of the closed cab panel lines up with the outside edge of the center of the bulkhead.

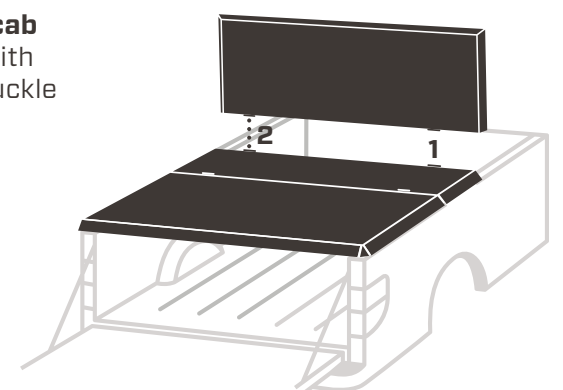

CONTINUED ON REVERSE >

- 11 Loosely affix the center panel to the truck by finger-tightening a **cap clamp** at each of the four interior corners of the underside of the center panel.

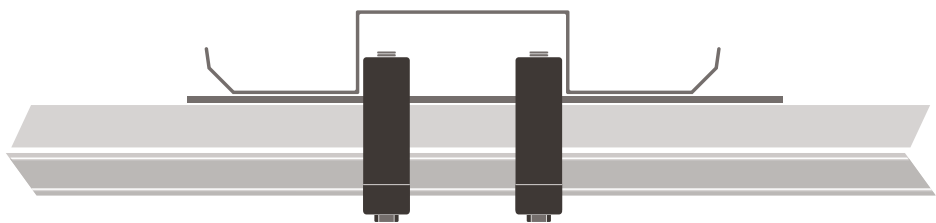

- ! The bottom halves of the cap clamps should be in the deck rail system.

- 12 Center the cover side to side on the truck.

- 13 Tighten the cap clamps with a 9/16" socket.

- ! Be careful not to tighten your clamps so much that they deform your bed rails.

- ! Road vibration can loosen your clamps. Retighten them after 100 miles. Check them every time you haul on top.

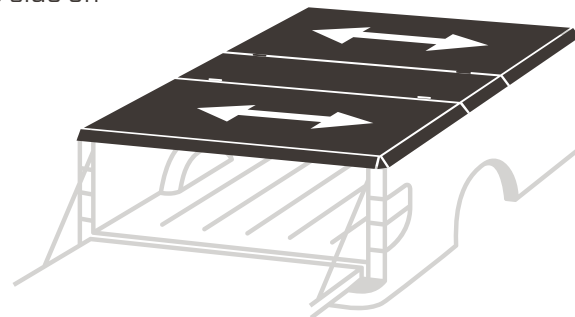

ADJUST THE LOCK RODS

- 14 Loosen the set screws on the tail-panel lock-rod linkages.

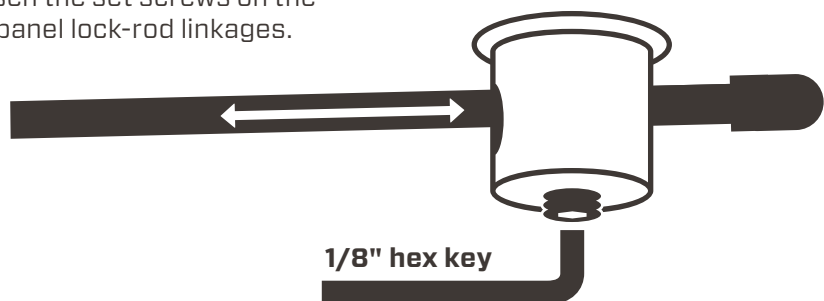

- 15 Adjust the length of the tail-panel lock rods and retighten their set screws so that:

- A. with the lock handle in the open position, the rod tips clear the striker brackets,
- B. with the handle in the closed position, the rod tips do not strike the brackets, and
- C. the first bend in the rods points downward.

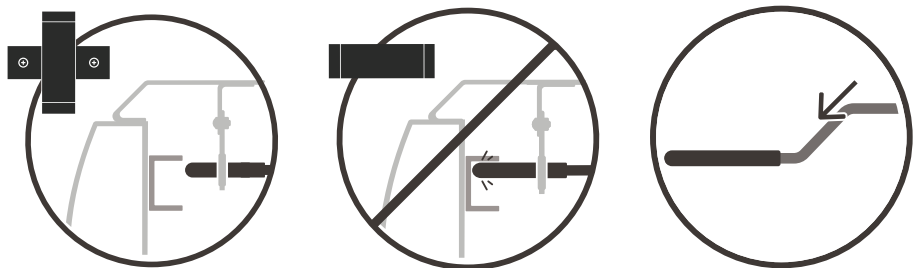

- 16 With the lock handle in the closed position, position the lock rods tight against the underside of the bend in the striker brackets so that the rods draw the panels down and compress the weatherstrip. Tighten the rod guide brackets with a 7/16" socket.

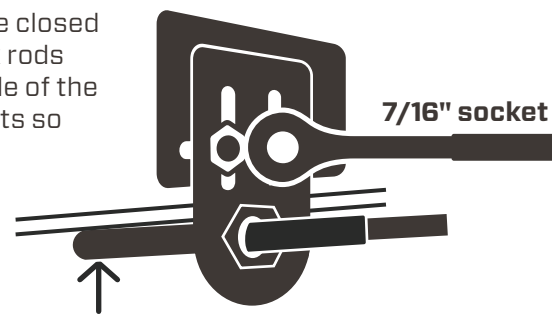

- ! For best weather protection, have a second person press down on the cover while you adjust the lock rods.

- ★ Operating the access panels is easiest when you press down as you open or close them.

- 17 Repeat steps 14 through 16 for the cab-panel lock rods, but use the inside of the deck rails instead of the bends in the striker brackets.

- ★ Your panels should be hard to operate at first. After finishing install below, leave the panels closed as much as possible for 3-4 days to break in the weatherstrip. After that period, you should find that the panels open and close without difficulty.

- ★ If you are also installing a **Cross Bin**, do so now. Refer to the **Cross Bin Installation Guide** for details.

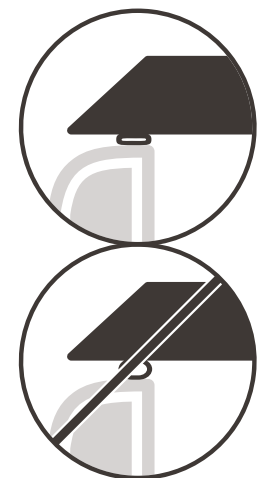

ATTACH THE SAFETY CATCH & GAS SPRINGS

- 18 Open the cab panel. Have a second person support it in the open position.

- 19 Slip the looped ends of the cable tethers that are attached to the underside of the cab panel around the center-panel ball stud arms, well past the ball studs.

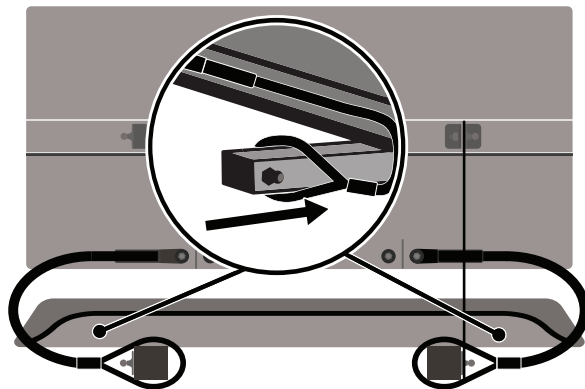

- 20 Fit the safety catch, which is hanging from the driver side of the cab panel, around the bottom ball stud.

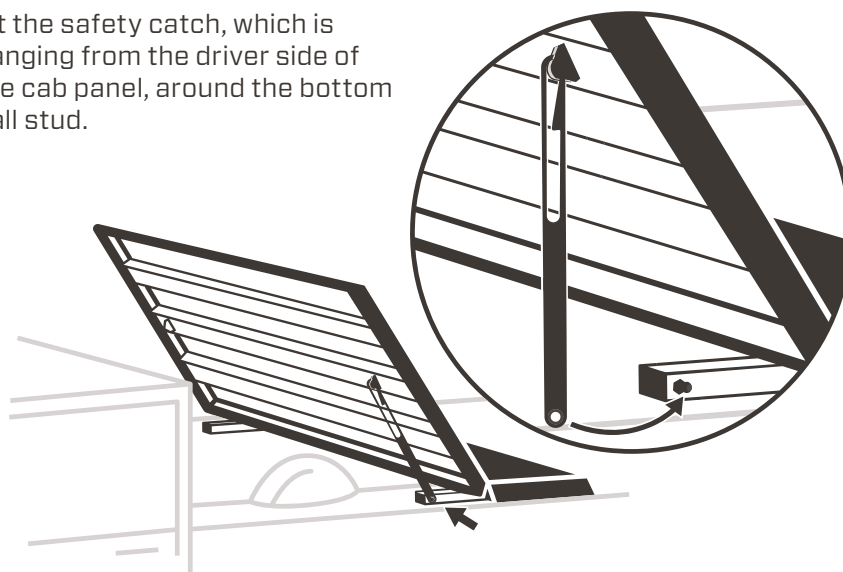

- 21 Attach a **gas spring** to the ball studs alongside the safety catch.

- ★ If some of your gas springs have heavier poundage printed on their sides than others, use the stronger ones on the cab panel.

- ! To avoid premature failure of your gas springs, attach them barrel up, shaft down.

- 22 Attach the three remaining gas springs (barrel up, shaft down).

- 23 If you have a '05-15 Tacoma, affix the included **bulkhead weatherstrip**. Refer to the **Bulkhead Prep Kit Installation Guide** for details.

- 24 Leave the cover closed and locked for 24 hours to allow the weatherstrip adhesive, which is pressure-sensitive, to fully cure.

24 hours
Adhesive cure time

