



INSTALLATION GUIDE

60 minutes Normal install time

Keep an eye out for these icons:

IMPORTANT! Important installation information

Helpful Hints Tips to assist installation

PARTS INCLUDED:

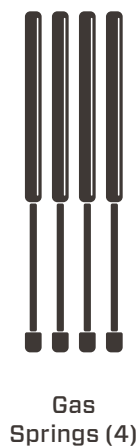
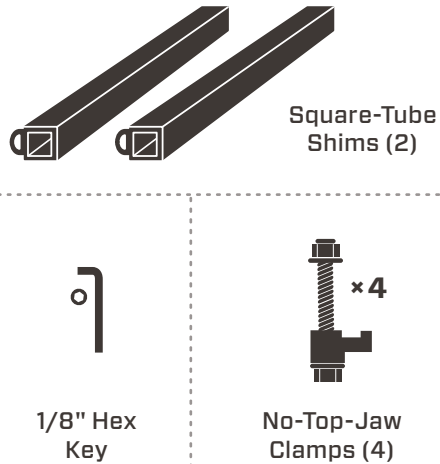
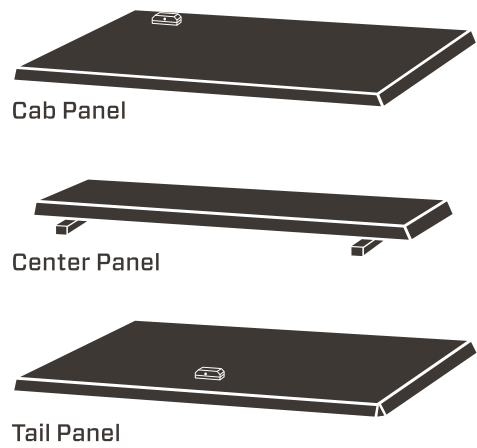

TOOLS REQUIRED:

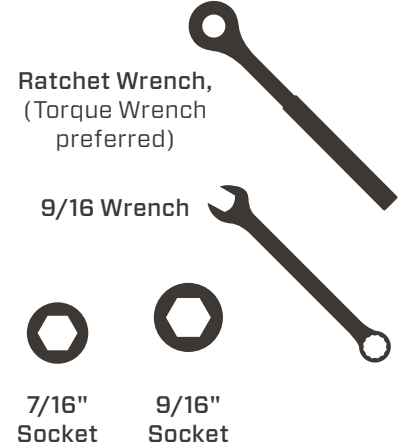
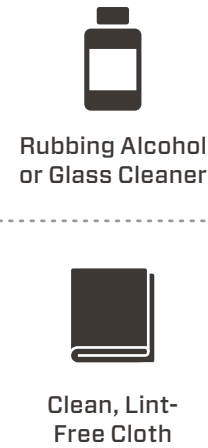

PRE-INSTALLATION NOTES (REVIEW ALL OTHER INCLUDED INSTALLATION GUIDES BEFORE BEGINNING)

Most trucks require the bulkhead weatherstrip to be installed and some require additional bulkhead preparations. Please refer to the instructions in the Bulkhead Prep Kit prior to mounting the cover.

If you're installing a rear window protection accessory, mount it prior to mounting the cover.

IDENTIFY & PREPARE THE CARGO BED

1 Identify which track system your RAMBOX system uses. If you have the silver track, please proceed to step 2 of this guide. If you have the black track, skip to attached guide CVR-8b which is specific to that system.

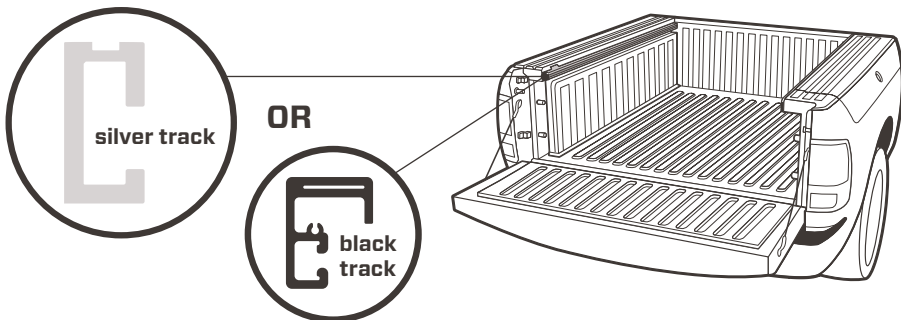

2 Clean the top of the utility tracks thoroughly with a clean, lint-free cloth and rubbing alcohol or glass cleaner. Allow to dry.

3 Remove the adhesive backing from the underside of the square-tube shims before affixing a square-tube shim to the top of each track, ensuring that...

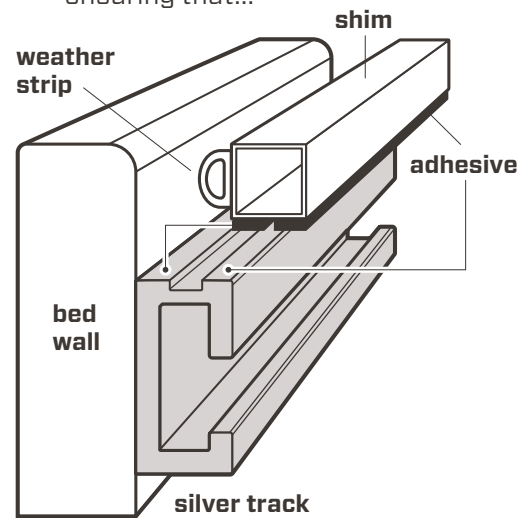

- A The forward end is tight against the bulkhead.
B The weatherstripped side of shim is tight against the bed wall.
C The adhesive strip faces down onto the top of the silver track.

MOUNT THE PANELS

4 Place the center panel across the bed cheated toward the tailgate.

Each panel is tapered front to back. Make sure the arrow on the underside of the panel is pointed toward the tailgate.

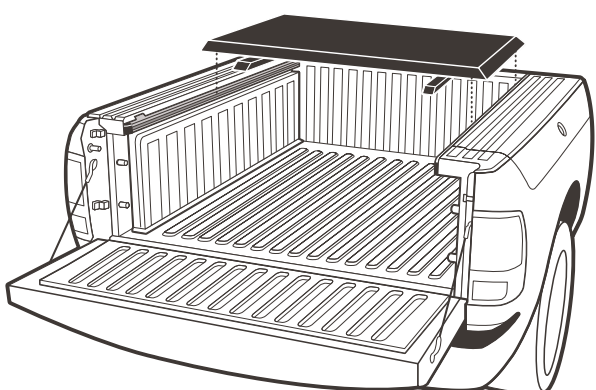

5 Attach the tail panel by holding it at a 90 degree angle from the bed rails and begin to mate the driver's side hinge first which is slightly longer.

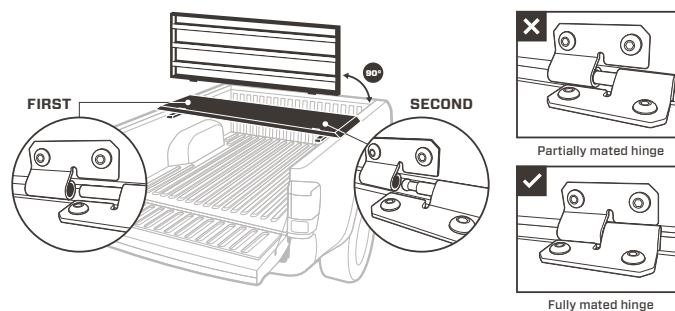

Mating hinges is easiest when you engage the longer pin first.

3 In the same way, attach the cab panel by holding it at a 90 degree angle from the bed rails and begin to mate the passenger side hinge first which is slightly longer.

CAUTION! Be sure all hinges are fully mated before lowering panels.

6 Position the cover front to back so that the front of the cab panel lines up with the outside edge of the center of the bulkhead. Center the cover side-to-side on the truck.

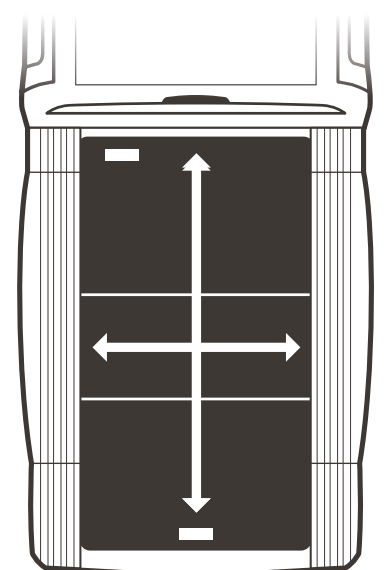

## POSITIONING CLAMPS

**7** Position the clamps so that the lower jaw is seated in the track and the bolt goes up through the slot in the center panel clamp strip. Uniformly tighten the clamps using a 9/16" socket and 9/16" wrench to between **4-5 ft-lbs**.

★ When tightening, use the wrench on the bottom and socket wrench on top for smoothest installation.

! **Retighten after a week of use. Check them every time you haul on top.**

★ Removal of track mounted accessories can make installation smoother.

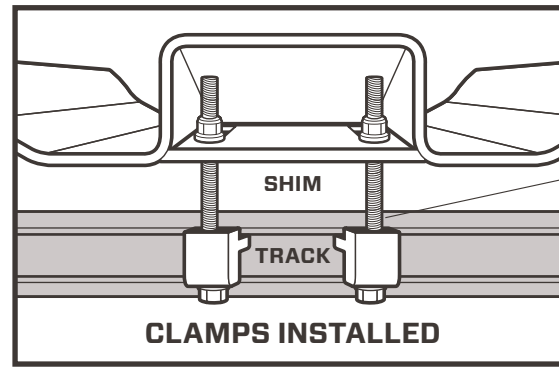

## ADJUST THE LOCK RODS

**8** Unbolt and move one of the bolts of the lock-rod guide brackets to the second, unoccupied slot using a 7/16" socket. Repeat this on each of the cover's four brackets.

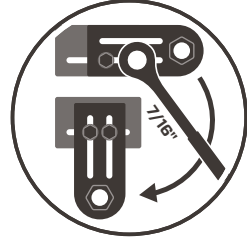

**9** Loosen set screws for the tail and cab panel lock rods with the provided hex key and retighten each lock rod after ensuring **three things...**

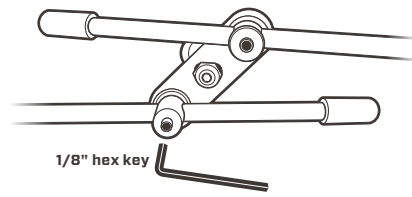

**CORRECT ORIENTATION** ■ HANDLE CLOSED + HANDLE OPEN

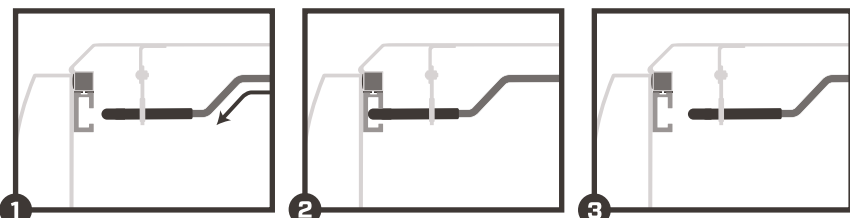

**1** The Z bend orientation is always maintained

**2** With the lock handle in the closed position, be sure the lock rods land inside the track and are engaged as far as possible.

**3** With the lock handle in the open position, ensure the rod tips clear the track.

**10** After properly aligning the lock rods in the closed position, it is time to tighten all brackets using a 7/16" socket. To ensure a tight seal, it is crucial to simultaneously push up on the bracket AND apply downward pressure on the cover. Repeat for all bracket locations.

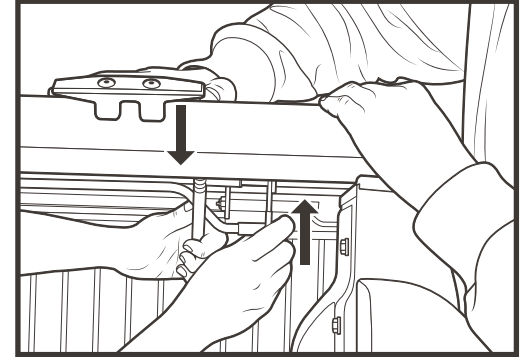

! **The panels may be tough to open and close at first. Leave the panels closed as much as possible to allow the weatherstrip to break in. After a few days, you'll find things working smoothly.**

★ The cab panel has a safety spring lock handle ensuring you engage the lock rods when closing the panel. This helps prevent accidental opening of the panel while driving.

## ATTACH THE GAS SPRINGS & SAFETY CATCH

**11** Open the cab panel. Have a 2nd person support it in the open position. Loop the end of the cable tethers around the ball stud arms, making sure to go beyond the ball stud and nut.

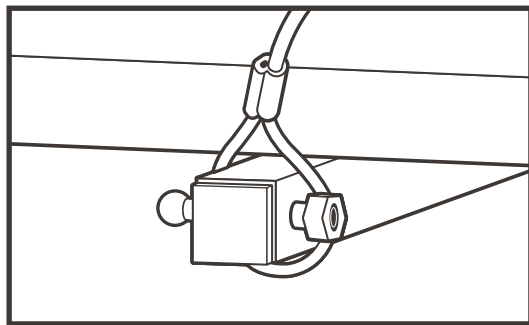

**12** Attach 2 gas springs to the cab panel.

! **Make sure the barrel end is up. If you install your gas springs upside down, they'll fail.**

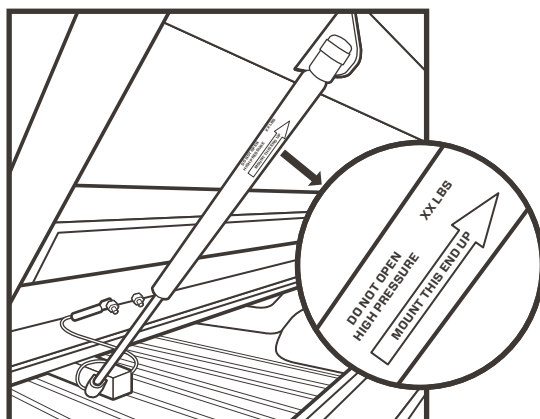

★ If 2 of your gas springs have heavier poundage printed on them, use them here.

**13** Attach the safety catch by pulling down on the panel and pushing the keyhole at the bottom of the safety catch around the nut, making sure to engage the spring clip.

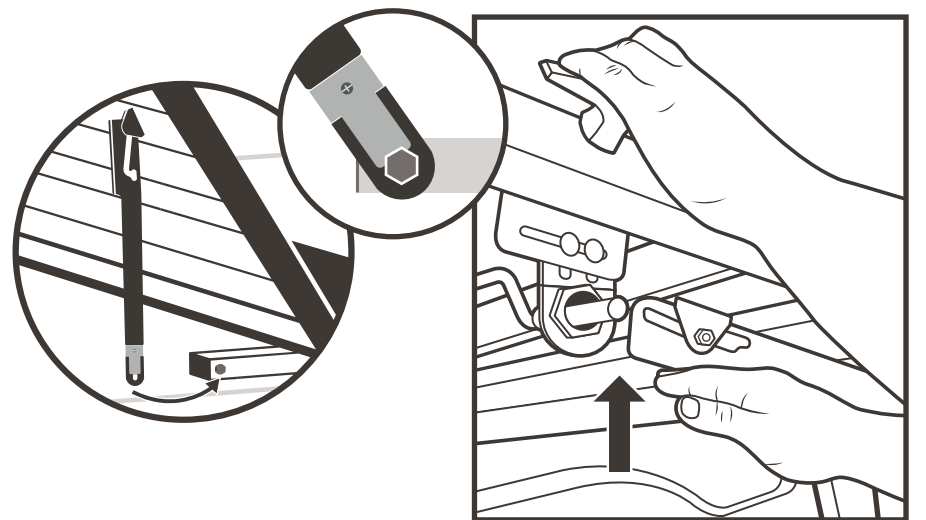

★ With the safety catch in place, your cab panel will only open partially. To fully open the panel, pull down on panel while using your other hand to push up on the flat part of the catch until it disengages.

**14** Attach the 2 remaining gas springs on the tail panel, again making sure the barrel end is up.

**15** Leave the cover closed and locked for 24 hours to allow the pressure-sensitive weatherstrip adhesive to fully cure.

🕒 **24 hours**  
Adhesive cure time

📅 **For first 2 weeks after installation**  
open tail panel on cover before operating tailgate.



# DIAMONDBACK

## Ram Trucks with RamBox Cargo Management System (Black Track)



# INSTALLATION GUIDE

CVR-8b

**45 minutes**  
Normal install time

Keep an eye out for these icons:

**IMPORTANT!**  
Important installation information

**Helpful Hints**  
Tips to assist installation

### PARTS INCLUDED:



Cab Panel



Center Panel



Tail Panel



Gas Springs (4)



1/8" Hex Key

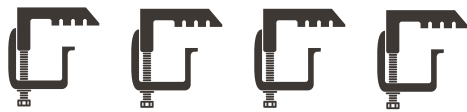

Cap Clamps (4)

### TOOLS REQUIRED:

Ratchet Wrench,  
(Torque Wrench preferred)



9/16" Socket



7/16" Socket

### PRE-INSTALLATION NOTES (REVIEW ALL OTHER INCLUDED INSTALLATION GUIDES BEFORE BEGINNING)

If you're installing a rear window protection accessory, mount it prior to mounting the cover.

Some models require bulkhead preparation first. Please refer to the instructions in the bulkhead prep kit prior to mounting the cover.

### IDENTIFY TRACK & MOUNT THE PANELS

**1** Identify the track type. If track is silver, flip to previous page for appropriate install instruction.



**2** Place the center panel across the bed cheated toward the tailgate.

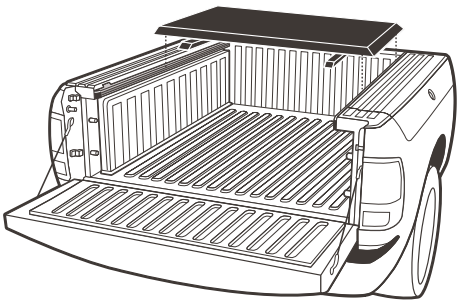

**!** Each panel is tapered front to back. Make sure the arrow on the underside of the panel is pointed toward the tailgate.

**3** Attach the tail panel by holding it at a 90° angle from the bed rails and begin to mate the driver's side hinge first which is slightly longer.

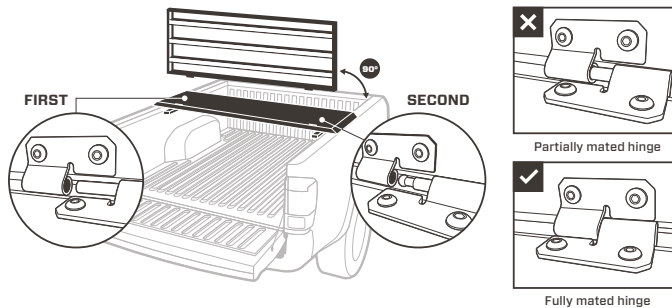

**★** Mating hinges is easiest when you engage the longer pin first.

**4** In the same way, attach the cab panel by holding it at a 90° angle from the bed rails and begin to mate the passenger side hinge first which is slightly longer.

**CAUTION!** Be sure all hinges are fully mated before lowering panels.

**5** Position the cover front to back so that the front of the cab panel lines up with the outside edge of the center of the bulkhead. Center the cover side-to-side on the truck.

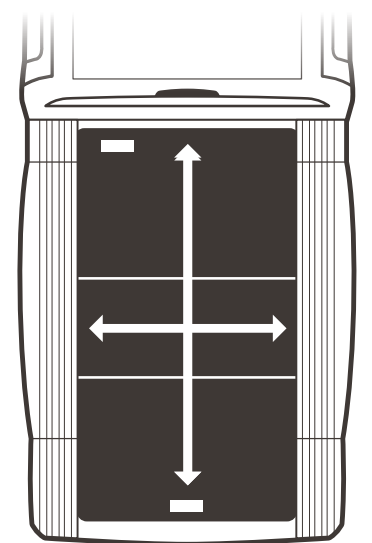

### POSITIONING CLAMPS

**6** Position the cap clamps as far apart as possible under the center panel. The clamp's top jaw gripping the cover's clamp strip and its bottom jaw gripping the top section of the track as shown. Uniformly tighten the clamps using a 9/16" socket to between 4-5 ft-lbs.

**!** Retighten after a week of use. Check them every time you haul on top.

**★** Removal of track mounted accessories can make installation smoother.

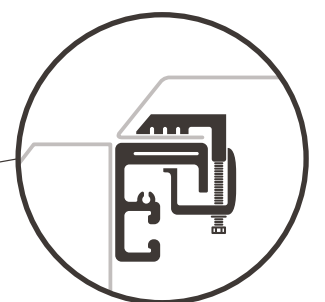
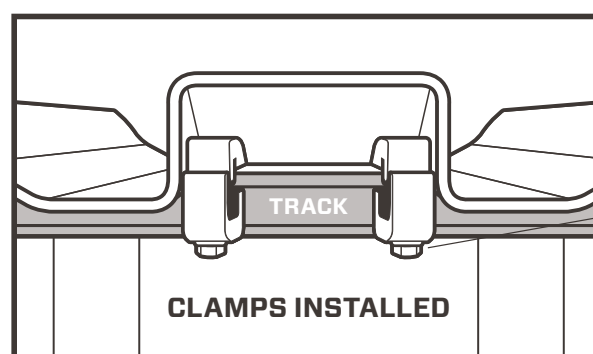

## ADJUST THE LOCK RODS

**7** Unbolt and move one of the bolts of the lock-rod guide brackets to the second, unoccupied slot using a 7/16" socket. Repeat this on each of the cover's four brackets.

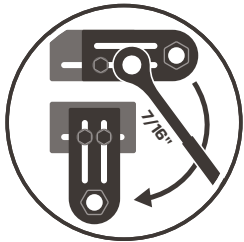

**8** Loosen set screws for the tail and cab panel lock rods with the provided hex key and retighten each lock rod after ensuring **three things...**

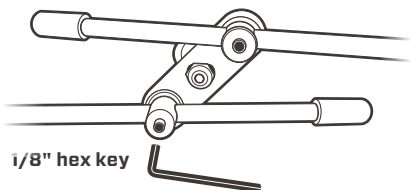

**CORRECT ORIENTATION**

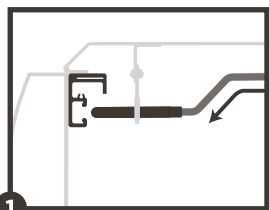

**1** The Z bend orientation is always maintained

**HANDLE CLOSED**

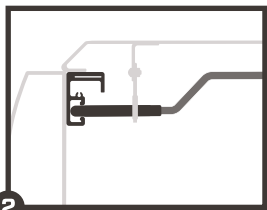

**2** With the lock handle in the closed position, be sure the lock rods land inside the track and are engaged as far as possible.

**HANDLE OPEN**

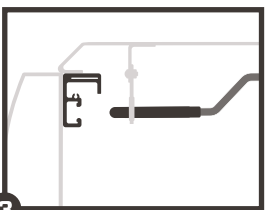

**3** With the lock handle in the open position, ensure the rod tips clear the track.

**9** After properly aligning the lock rods in the closed position, it is time to tighten all brackets using a 7/16" socket. To ensure a tight seal, it is crucial to simultaneously push up on the bracket AND apply downward pressure on the cover. Repeat for all bracket locations.

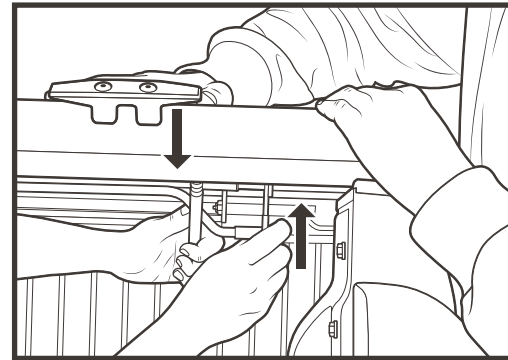

**!** The panels may be tough to open and close at first. Leave the panels closed as much as possible to allow the weatherstrip to break in. After a few days, you'll find things working smoothly.

**★** The cab panel has a safety spring lock handle ensuring you engage the lock rods when closing the panel. This helps prevent accidental opening of the panel while driving.

## ATTACH THE GAS SPRINGS & SAFETY CATCH

**10** Open the cab panel. Have a 2nd person support it in the open position. Loop the end of the cable tethers around the ball stud arms, making sure to go beyond the ball stud and nut.

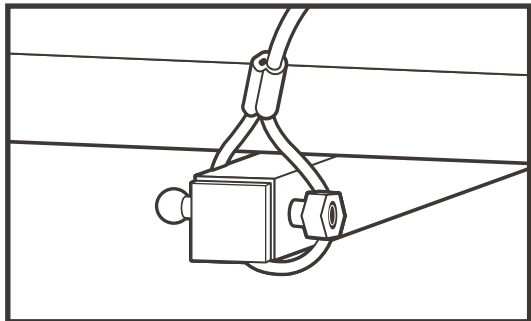

**11** Attach 2 gas springs to the cab panel.

**!** Make sure the barrel end is up. If you install your gas springs upside down, they'll fail.

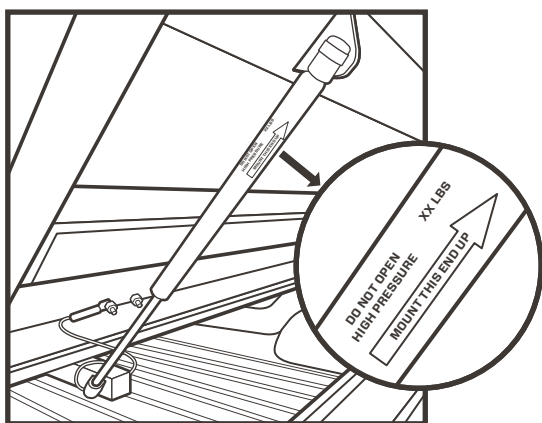

**★** If 2 of your gas springs have heavier poundage printed on them, use them here.

**12** Attach the safety catch by pulling down on the panel and pushing the keyhole at the bottom of the safety catch around the nut, making sure to engage the spring clip.

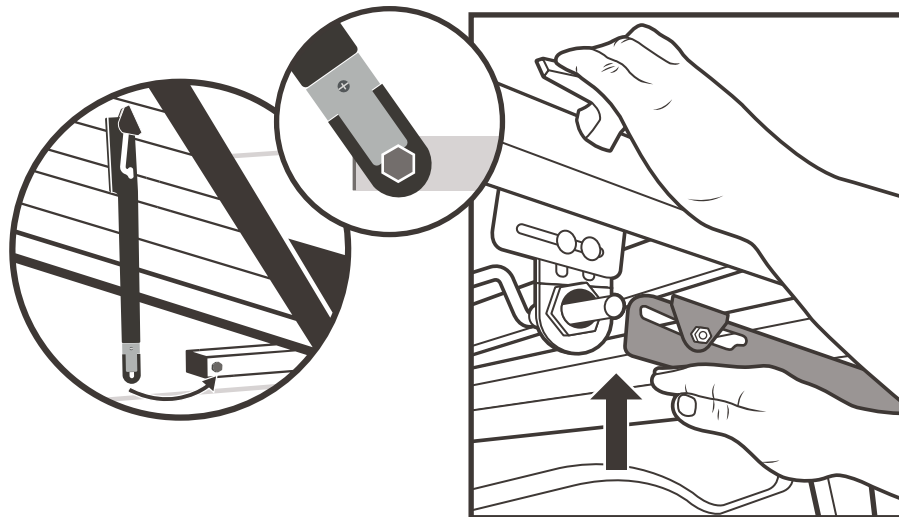

**★** With the safety catch in place, your cab panel will only open partially. To fully open the panel, pull down on panel while using your other hand to push up on the flat part of the catch until it disengages.

**13** Attach the 2 remaining gas springs on the tail panel, again making sure the barrel end is up.

**14** Leave the cover closed and locked for 24 hours to allow the pressure-sensitive weatherstrip adhesive to fully cure.

**🕒 24 hours**  
Adhesive cure time

**📅 For first 2 weeks after installation**  
open tail panel on cover before operating tailgate.