



INSTALLATION GUIDE

CVR-180.5

60 minutes
Normal install time

Keep an eye out for these icons:

IMPORTANT!
Important installation information

Helpful Hints
Tips to assist installation

PARTS INCLUDED:

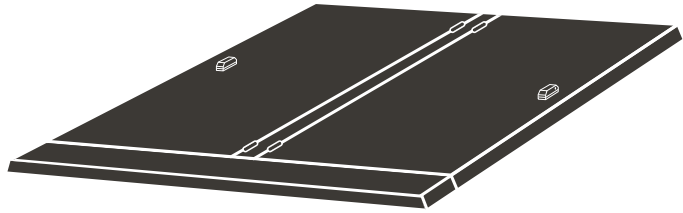

180 Cover



Bulkhead Angle



1/4" Self-Drilling Screws (5)



1/4" Steel Rivet Nuts (5)



1/8" Hex Key



Gas Springs (4)



Threaded Insert Installation Tool



1/4" Plain Washers (5)



1/4" Hex Bolts (5)



G-913 Clamps (2)

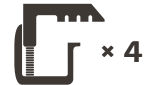

G-99 Clamps (4)

TOOLS REQUIRED:



Marker



Drill



3/8" Nut Driver



25/64" Drill Bit



Hammer



9/16" Wrench



Ratchet Wrench



7/16" Socket



9/16" Socket

PRE-INSTALLATION NOTE:

If your truck has bed rail caps, you should affix the included **bulkhead prep kit** prior to installing the DiamondBack 180.

PREPARE THE BULKHEAD

1 Attach the **bulkhead angle** to the bulkhead just below the "shelf" at the top, centered side to side, and longer leg down using a drill, 3/8" nut driver bit, and five self-drilling screws.

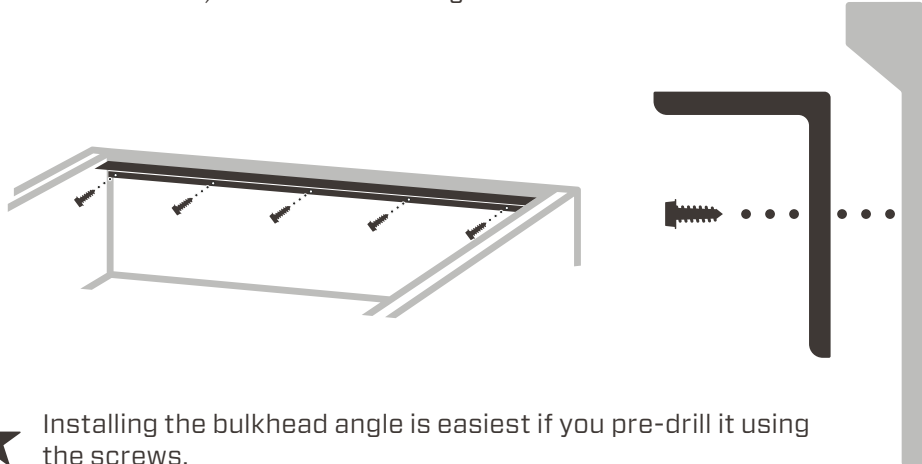

★ Installing the bulkhead angle is easiest if you pre-drill it using the screws.

2 Detach the bulkhead angle by removing the self-drilling screws.

3 Use the holes in the truck body left by the self-drilling screws as pilot holes to drill larger, 25/64" holes.

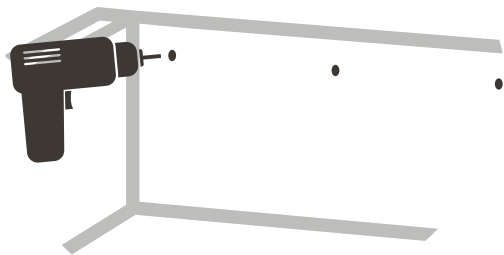

★ If you don't have a 25/64" bit, use a 3/8" bit and slightly ream the holes.

4 Hammer a **rivet nut** into each hole.

5 Insert the **installation-tool** mandrel into a rivet nut. Hand-tighten it until its hexagonal sleeve is tight to the face of the rivet nut.

6 Use a 9/16" wrench to hold the installation-tool sleeve as you tighten the mandrel with a 7/16" socket until the rivet nut deforms and locks against the interior of the bed wall.



★ You'll know the rivet nut is fully compressed when you feel the mandrel become very difficult to turn.

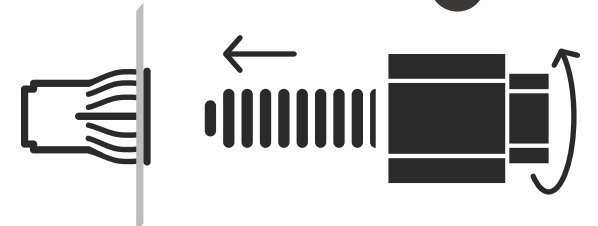

7 Remove the installation tool by unscrewing the mandrel.

8 Repeat steps 5-7 for each hole and rivet nut.

9 Re-install the bulkhead angle by inserting a hex bolt through a plain washer, through each hole in the angle, and into each rivet nut. Tighten with a 7/16" socket.

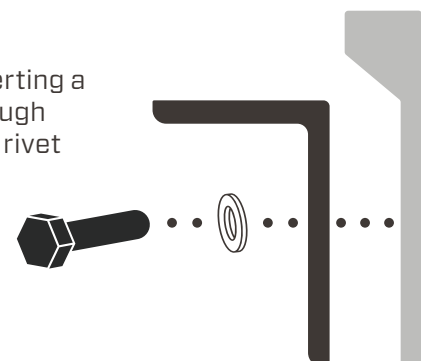

10 If you are also installing a **Cross Bin**, do so now. Refer to page 2 of the Cross Bin Installation Guide for details.

MOUNT THE COVER

11 Close the tailgate. Place the **cover** onto the cargo bed so that the weatherstrip along the cover's rear angle is firmly compressed against the inside edge of the tailgate.

12 Center the cover side to side.

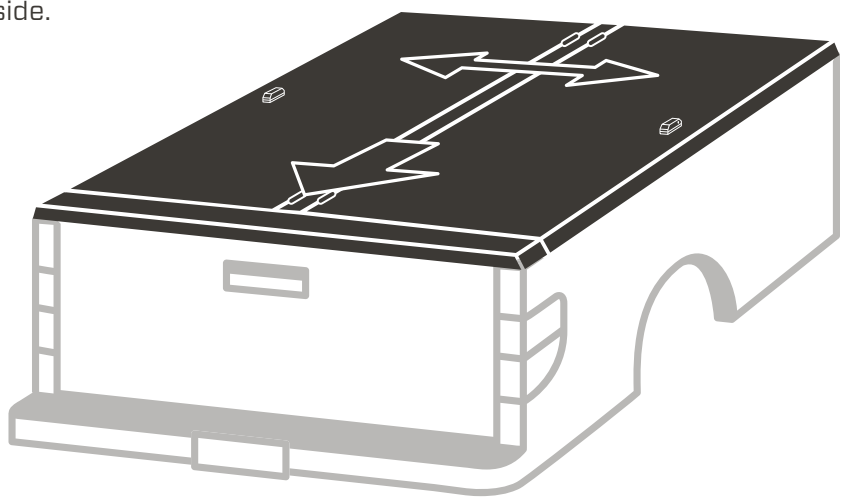

13 Attach the nose of the T panel to the bulkhead angle using the **G-913 clamps**. Tighten the clamps with a 9/16" socket.

14 Attach the cross member of the T panel to the bed rails using two **G-99 clamps** at each end. Tighten.

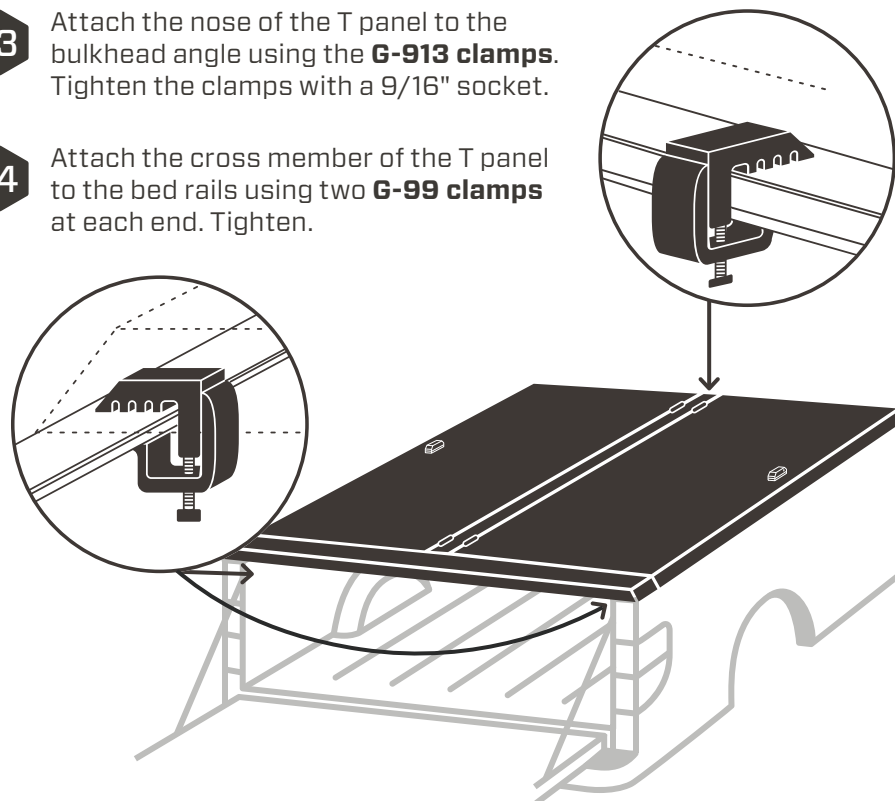

ADJUST THE LOCK RODS

15 Use the 1/8" **hex key** to loosen the set screws on the linkages of the forward lock rods.

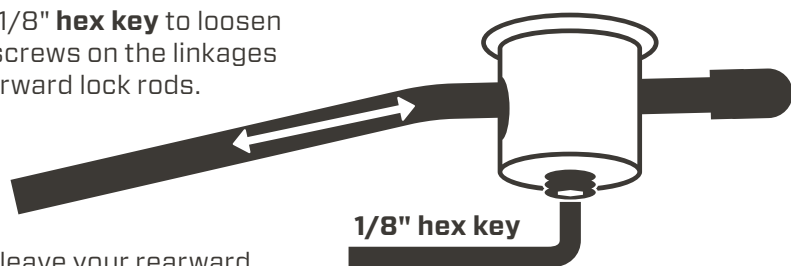

★ You can leave your rearward lock rods alone. They come pre-adjusted from the factory.

16 Adjust the length of the lock rods & retighten the set screws so that:

- A. with the lock handle in the open position, the rod tips clear the bulkhead angle,
- B. with the handle in the closed position, the rod tips do not strike the bulkhead, and
- C. the rods point downward.

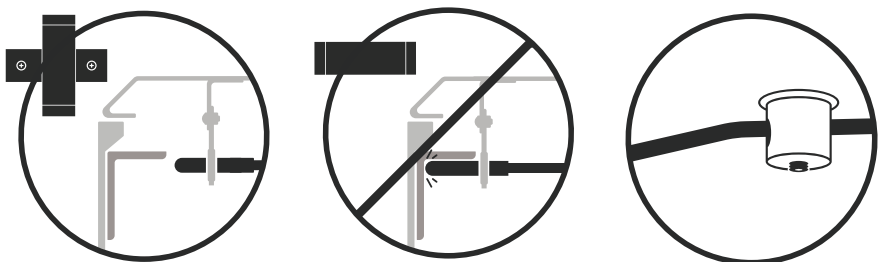

17 With the lock handle in the closed position, set the lock rods tight against the underside of the bulkhead angle on Nissans or the inside of the deck rail on Tundras. Tighten the rod guide brackets with a 7/16" socket.

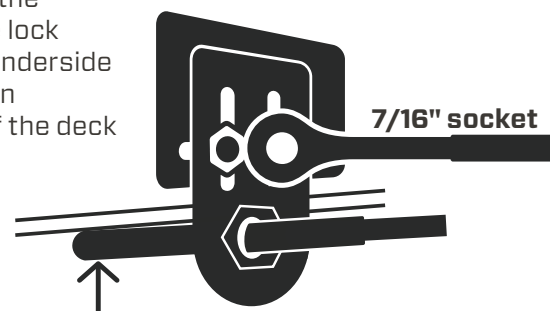

18 Double-check both panels to ensure they open, close, lock & seal correctly. If at any point the weatherstrip does not touch the bed rails, readjust the lock rods and mounting brackets as needed.

★ Operating the access panels is easiest when you press down as you open or close them.

ATTACH THE GAS SPRINGS

19 Attach the **gas springs** to the ball studs.

! To avoid premature failure of your gas springs, attach them barrel up, shaft down.

20 Leave the cover closed and locked for 24 hours to allow the weatherstrip adhesive, which is pressure-sensitive, to fully cure.

24 hours
Adhesive cure time

