



DIAMONDBACK

DiamondBackCovers.com / 800 935 4002

2005-up Nissan Frontier,
2004-2015 Nissan Titan &
2007-up Toyota Tundra w/Deck Rail

180

INSTALLATION GUIDE

CVR-180.4

60 minutes
Normal install time

Keep an eye out for these icons:

IMPORTANT!
Important installation information

★ Helpful Hints
Tips to assist installation

PARTS INCLUDED:

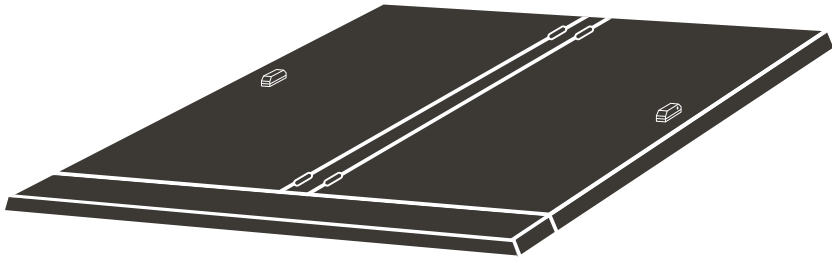

180 Cover

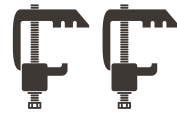

Cap Clamps (2)
exact appearance varies



1/4" Steel
Rivet Nuts (4)



Threaded Insert
Installation Tool



Gas
Springs (4)



1/4" Hex
Bolts (4)

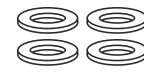

1/4" Plain
Washers (4)



1/8" Hex Key

TOOLS REQUIRED:



Marker



Drill



3/8" Bit



Hammer



9/16"
Wrench



Ratchet
Wrench



7/16" Socket



9/16" Socket

PRE-INSTALLATION NOTES:

If your truck has bed rail caps, you should affix the included **bulkhead prep kit** prior to installing the DiamondBack 180. Refer to the **Bulkhead Prep Kit Installation Guide** for details.

You'll want a second person to help with this installation.

If you are installing a **Cross Bin**, you should start that installation before you install the DiamondBack 180. Refer to page 2 of the **Cross Bin Installation Guide** for details.

PREPARE THE CARGO BED

1 Close the tailgate. Place the **cover** onto the cargo bed so that the weatherstrip along the cover's rear angle is firmly compressed against the inside edge of the tailgate.

2 Center the cover side to side.

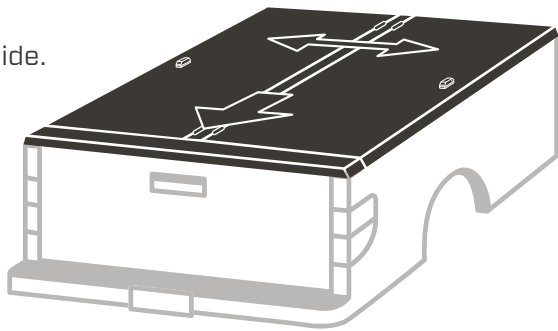

3 Open the tailgate. At the rear of the bed, mark drill locations on both bed walls using the mounting-bracket slots as a template.

★ Cheat these marks slightly lower than the vertical center of the slots.

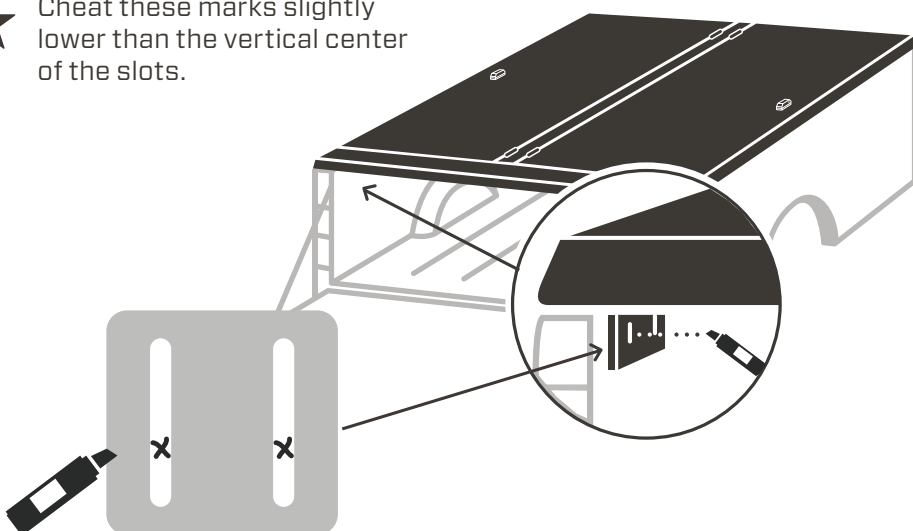

4 Remove the cover.

5 Drill the marks using a 3/8" bit.

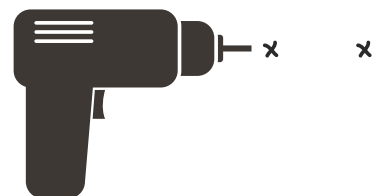

6 Hammer a **rivet nut** into each hole.

7 Insert the **installation-tool** mandrel into a rivet nut. Hand-tighten it until its hexagonal sleeve is tight to the face of the rivet nut.

8 Use a 9/16" wrench to hold the installation-tool sleeve as you tighten the mandrel with a 7/16" socket until the rivet nut deforms and locks against the interior of the bed wall.



★ You'll know the rivet nut is fully compressed when you feel the mandrel become very difficult to turn.

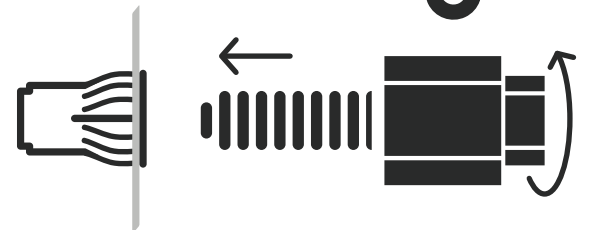

9 Remove the installation tool by unscrewing the mandrel.

10 Repeat steps 7-9 for each hole and rivet nut.

MOUNT THE COVER

11 Repeat step 1.

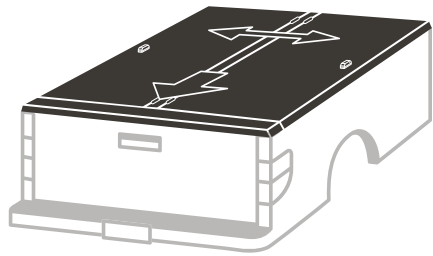

12 Insert a hex bolt through a plain washer, through each bracket slot, and into each rivet nut. Tighten with a 7/16" socket.

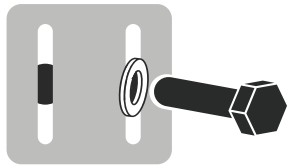

! To get the weatherstrip compression necessary for its adhesive to cure and for the cover to keep out the weather, have a second person press down on the rear of the cover while you're attaching the mounting brackets.

13 Attach the front of the cover to the bottom of the bulkhead angle (Nissans) or to the inside of the deck rail (Tundras) using the **cap clamps**. Tighten the clamps with a 9/16" socket.

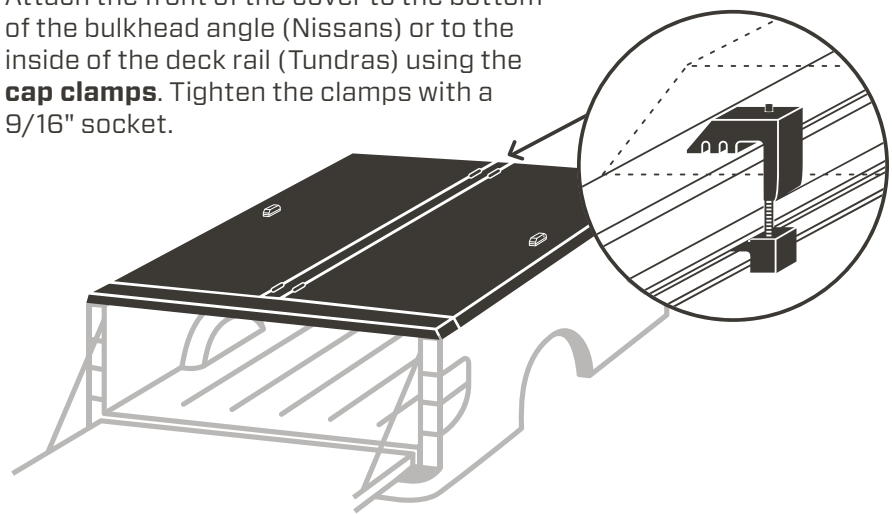

! Retighten your clamps after 100 miles. Check them every time you haul on top.

ADJUST THE LOCK RODS

14 Use the 1/8" **hex key** to loosen the set screws on the linkages of the forward lock rods.

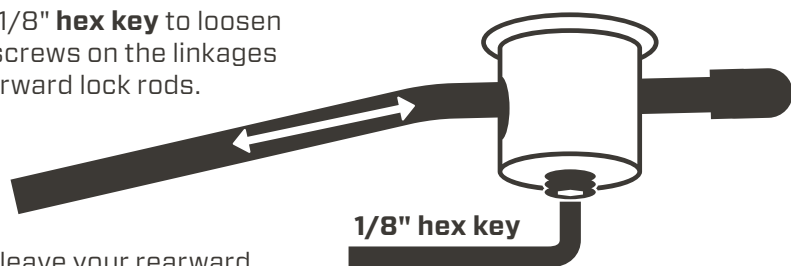

★ You can leave your rearward lock rods alone. They come pre-adjusted from the factory.

15 Adjust the length of the lock rods & retighten the set screws so that:

- A. with the lock handle in the open position, the rod tips clear the bulkhead angle (Nissans) or deck rail (Tundras),
- B. with the handle in the closed position, the rod tips do not strike the bulkhead, and
- C. the rods point downward.

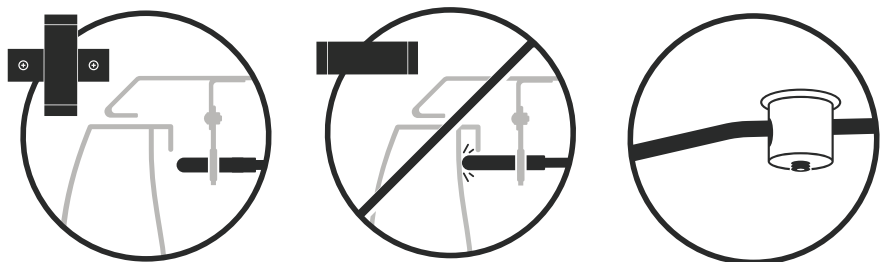

16 With the lock handle in the closed position, set the lock rods tight against the underside of the bulkhead angle on Nissans or the inside of the deck rail on Tundras. Tighten the rod guide brackets with a 7/16" socket.

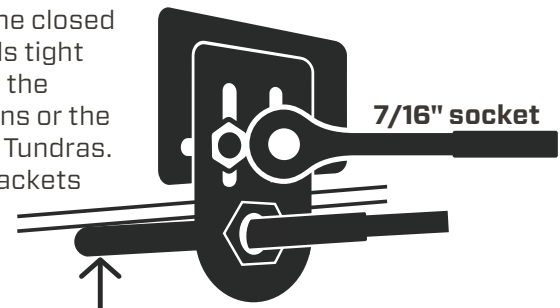

17 Double-check both panels to ensure they open, close, lock & seal correctly. If at any point the weatherstrip does not touch the bed rails, readjust the lock rods and mounting brackets as needed.

★ Operating the access panels is easiest when you press down as you open or close them.

ATTACH THE GAS SPRINGS

18 Attach the **gas springs** to the ball studs.

! To avoid premature failure of your gas springs, attach them barrel up, shaft down.

19 Leave the cover closed and locked for 24 hours to allow the weatherstrip adhesive, which is pressure-sensitive, to fully cure.

🕒 **24 hours**
Adhesive cure time

