

Ultrasonic Liquid Flowmeter

QUICK User Manual



Take 5, Inc.

1335 Dayton Street Unit A

Salinas, CA 93901

Dave@TacticalFlowMeter.com

Call (831)-244-8080

Rev 17: Updated Energy ModBus units to G

0. Specifications

- Medium: Any acoustically conductive fluid with less than 5% air bubbles or solids
- Pipe size: ¼" to 240" Pipe clamps used for 1" to 4" Pipe. Spring and cable for above 4" pipes.
- Flow rate: Calculate using Velocities up to 12 m/s
- Temperature: - 20 - 110 °C
- Transducer material: Aluminum and 304 SS
- Cable length: 8' - 25'
- Accuracy: ±1% from 0.15 to 40 f/s (0.05 to 12 m/s)
- Resolution: 0.01 ft/s (0.00025 m/s)
- Response time: 150 ms measuring cycle typical
- Transducer Frequency: 1 MHz
- Clamp-on transducers: encapsulated design IP68
- Enclosure Protection Grade: IP65
- Display LCD Screen
- Power Supply: 8-36 VDC or 86-240 VAC Universal Power Supply
- Output: 4-20mA + 0-10K Hz + Standard ModBus RTU Communication protocol
- Note: For 1 to 5 VDC output, add 250 Ohm resistor to 4 to 20 mA loop.

1. Overview

§1.1 Preface

The wall-mounted type ultrasonic flowmeter, can be used for nearly any liquid from water, sewer water, petrol chemicals, metallurgy, electric power plant coolant flow, irrigation, city water, energy monitoring, the meter can indicate flow velocity, flow rate, total flow for nearly any fluid.



§1.2 Principle of Operation

When an ultrasonic beam is transmitted through a flowing liquid, there is a difference between the upstream and downstream transit time that is proportional to the fluid flow velocity. When the fluid is flowing, the reverse transit time is greater than the forward flow transit time. This allows us to measure a time difference and that difference is due to the fluid flow velocity measured across the ultrasonic flow path across a known internal pipe diameter that allows the calculation of Flow from $Q = AV$ where the A is derived from the pipe diameter D.

Variable Names:

θ : The angle between the ultrasonic beam and the flow.

M: Transit times of the ultrasonic beam.

D: The internal diameter of the pipe.

T_{up} : Transit time in the forward direction.

T_{down} : Transit time in the reverse direction.

$\Delta T = T_{up} - T_{down}$

$$V = \frac{MD}{\sin 2\theta} \times \frac{\Delta T}{T_{up} \cdot T_{down}}$$

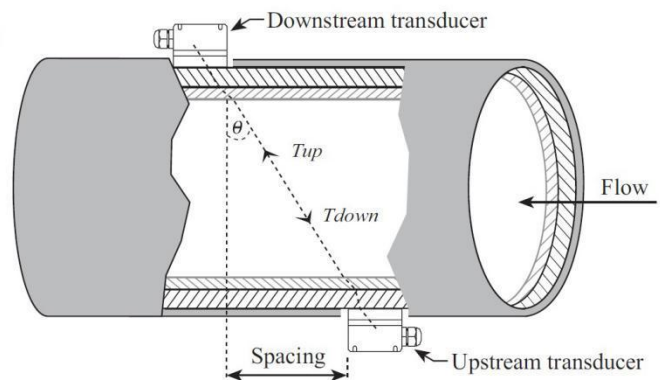

2. Specifications

This instrument consists of the main electronics with the display and user interface buttons. The most common configuration simply requires the main electronics and a pair of transducers to complete the flow measurement instrument.

§2.1 wall-mounted ultrasonic flowmeter

Features:

1 Power: 24 VDC or Universal 86-232 VAC 50/60Hz optional

2 Repeatability: better than 0.2%

3 Accuracy: +/- 1% Reading from 0.16 to 40 f/s (0.49 - 12 m/s)

4 signal outputs:

- one channel standard isolation ModBUS RTU, RS-485 output.
- one channel isolation 4-20mA or 0-20mA active output.
- one channel Open Collector Transistor, (OCT) output (programmable pulse width (6-1000ms), default (200ms)).

4 Display: 2*20 backlit LCD

5 User Interface: 4x4 tactile keypad sealed behind easy open door.

6 Other functions:

- Automatic memory for positive, negative, net totalized flow rate for 512 days with 10 year backup battery life.
- Automatic storage of power on/off and flow rate of the last 30 events. Reset can be manual or invoked automatically. The user may read the data through Modbus communication protocol.

7 Enclosure Ratings: Electronics IP65, Transducers are IP68

8 Ultrasonic Transducer: clamp-on.

3.Display and Operation

§3.1.1 key functions

The ultrasonic flowmeter can use 16 key keyboard interfaces at the same time or respectively. The keyboard can make users operate quickly and conveniently.

4*4 Keyboard, 16 keys keyboard overview:

0-9 and <•> are used to input digits or Menu number.

◀ key is used to move left, backspace, or delete the left character.

<▲/+> and <▼/-> are used to enter upper and lower Menu, when inputting digits, it invokes plus or minus keys.

Menu key is used to cycle through the menu selections. Press the Menu key and then press two digits keys to enter the related menu. For example, if inputting outside pipe diameter, press menu <1><1>. "11" is the address code of outside pipe diameter parameter.

<ENT > key is used for entering the input digit or chosen digits.

§3.1.2 Menu

Flow Rate & Fow Totalizer	00	Display flow rate / net totalizer, adjust the units with M30-M32
	01	Display flow rate / flow velocity, adjust the units with M30-M32
	02	Display flow rate / positive totalizer, adjust the units with M30-M32
	03	Display flow rate / negative totalizer, adjust the units with M30-M32
Display	04	Display flow rate / date time
	05	Display heat flow rate / total heat quantity, adjust the units with M84, M88.
	06	Display temperature input T1,T2
	07	Display present battery voltage
	07	Display analog input AI3, AI4
	08	Display system error codes
	09	Display today net totalizer
	10	Input outside perimeter of pipe
	*11	Input pipe outer diameter, data range: 1-72"
	*12	Input pipe wall thickness
	*13	Input pipe inner diameter

Initial Setup	*14	Select pipe material	
	15	Input sound velocity of pipe material	
	16	Input pipe liner type	
	17	Input the sound velocity of liner	
	18	Input the thickness of liner	
	19	Input inner pipe wall roughness	
	*20	Select fluid	
	21	Input fluid velocity	
	22	Input fluid viscosity	
	*23	Select Transducer type (Note: there are 20 types to choose from)	
Initial Setup	*24	Select transducer installation method	
	*25	Input display transducer installation spacing	
	*26	Input parameter method and setup	
	27	Store and read installation parameters at installation point	
	28	If the signal is poor select "yes", to display last correctly measured data.	
	29	Input signal strength low cut off. Inputting 65 will cause the flow rate to indicate as zero when the signal strength is lower than 65. The flow meter will indicate that there is no liquid in the pipe and display the flow value as zero.	
		30	Select metric or imperial units
		31	Select flow rate units
		32	Select totalizer units
		33	Totalizer K Factor. Factory value = 1.0
34		Select totalizer alarm point	

Flow	35	Select positive totalizer alarm point	
Units	36	Select negative totalizer alarm point	
Setup	37	Restore Factory values and reset totalizer	
	38	Manual totalizer reset enable (the key to control on/off)	
	39	Select language	
	30	LCD display mode, 0 or 1 is default display mode. 2-39 enables automatic cycle display method, displaying the previous menu of 2-39, time interval is 8 seconds	
	*40	Filter coefficient	
Setup	*41	Input low flow velocity cutoff value	
	42	Setup static zero point	
	43	clear zero point setup and manually setup zero point, restore factory default s	
	44	Set up zero measurement value	
	45	Meter coefficient	
	Setup	46	Input network address, identification number (IDN)
		47	Enable password
		48	Input linearizer data, up to 12 points.
Output Time Setup	49	Network communication test, verify data is transferred from computer to troubleshoot digital communication	
	50	Optional setup of data logger to output at selected time, select output of any of the 20 variables to record.	
Setup	51	Setup output time at a scheduled time	

	52	Printing data flow direction control. By default the printed data will flow directly to an optional thermal printer. Select Modbus RTU via (RS485 port)
AI5 Setup	53	Display analog input AI5 (reserved for the TDS16 mainboard)
Input & Output Setup	54	Setup of OCT totalizer pulse output, pulse width, range: 6 Ms-1000 Ms
	55	Select current loop mode
	56	Select output of current loop 4mA or 0mA
	57	Select data to output of current loop 20mA
	58	Current loop output validation, used to check whether current loop is functional
	59	Select current loop output value
	60	Date time and setup.
	61	Software version and Electronic Serial Number (ESN)
	62	Select serial port parameters
	63	Select Communication protocol MODBUS-RTU or MODBUS-ASCII or MODBUS-ASCII, previous 7 version protocol, FUJI protocol, Meter-BUSx protocol etc.
	64	Select analog input AI3 AI4 AI5 >> By selecting the measuring range, the flow meter will output the required current signal range.
	65	
	66	
	67	Select frequency output signal, default is 0-1000Hz, max-range is 0-9999 Hz.
	68	Select the lower limit flow of the frequency signal output
	69	Select the upper limit flow of the frequency signal output
	70	Set LCD backlight timer
	71	Set LCD contrast ratio

	72	Interval timer
	73	setup lower / upper limit of frequency signal output, LCD backlight control and LCD contrast ratio >> The lower and upper limits of the alarm may be configured to set a window alarm and the alarm signal can either control the OCT or the relay.
	74	
	75	
	76	
	77	
	78	Configure Open Collector Transistor output(OCT) output options
	79	Configure relay(OCT2) output options
	80	Configure input signal for external batch controller
	81	Enable batch controller
BTU/Heat Setup	82	Setup day/month/year totalizer, check the flow rate and heat quantity of the totalizers
	83	Automatically reset flow switch after power off, default status:off. This function may not be available under all conditions.
	84	Configure heat quantity unit, 0.GJ (default) 2.Kcal 4.BTU (imperial unit)
	85	Select temperature signal origin, selecting temperature signal AI3 or AI4, the temperature transmitter will be output on the 4-20mA current signal.
	86	Configure heat capacity, default: GB-CJ128 enthalpy potential method. Temperature difference method is also available.
	87	Configure heat quantity totalizer switch
	88	Configure Heat quantity multiplier factor
	89	Display present temperature difference and setup temperature difference sensitivity

	8	Configure supply or return configuration.
Diagnostics	*90	Display signal strength and signal quality
	*91	Display transit time ratio
	92	Display calculated fluid sound velocity.
	93	Display total transit time and the delta time
	94	Display Reynolds number and the pipe coefficient
Diagnostics	95	Display positive, negative heat quantity totalizer, start cycle display function.
Optional Menu Functions	+0	Display the time of power on/off and flow rate
	+1	Display total power up time of the flow meter
	+2	Display last time the power was off
	+3	Display the flow rate of the last power off
	+4	Display total time of power on
	+5	Calculator
	+6	Setup threshold value for fluid sound velocity
+7	Net current month totalizer value	

	+8	Net current year totalizer value
	+9	Operating time with errors (including power off time)
Hardware & Menu Config	.2	Store static zero point
	.5	Setup threshold Q value
	.8	Maximum flow rate of this day and this month
	.9	serial port validation window with CMM direct output
	-0	Hardware testing, requires password
	-1	4-20mA current loop calibration
	-2	AI3 calibration of analog input 4 mA
	-3	AI3 calibration of analog input 20mA
	-4	AI4 calibration of analog input 4mA
	-5	AI4 calibration of analog input 20mA
	-6	AI5 calibration of analog input 4mA
	-7	AI5 calibration of analog input 20mA
	-8	Zero point setup for PT100 at lower temperature (<40 C)
	-9	PT100 setup zero point at higher temperature (>55C)
	-A	PT100 standard calibration at 50C
-B	PT100 standard calibration at 84.5C	

* Font Color Key: Black for basic menus, red for advanced functions, blue for BTU and heat quantity measurement parameters.

§3.1.2a Flow Units

Flow Units

0	cubic meter	(m ³)
1	liter	(L)
2	American gallon	(GAL)
3	imperial gallon	(IGL)
4	American million gallon	(MGL)
5	Cubic feet	(CF)
6	US oil barrel	(1 barrel =42gallon) (OB)
7	Imperial oil barrel	(IB)

§3.1.3 Parameter storage for flow meter and options

The meter has 3 storage areas as follows:

1. Present parameter data block,
2. Solidification, or FLASH, parameter data block,
3. User pipe parameter data block.

Present parameter data block is stored in internal RAM, if the power supply and backup battery are both off then the data in the Present data block are lost.

Solidification (store factory values) parameter data block is stored in internal FLASH, under normal conditions this data will not be lost. Accessing the M26 function for solidification parameters will allow the user to either store the current data or recover stored data. Select "0" in M26 for portable instrument mode.

User pipe parameter data block is able to access and store 9 sets of commonly used pipe parameters. The access to this data block is in M27.

§3.1.4 Zero point setup and zero point solidification, or storage

Factory transducers are configured with a "zero point", to indicate when the fluid flow velocity is zero. This value may be adjusted to indicate any value of the flow meter under any flow velocity.

For example, let's assume that the zero point is 1m³/h, and the current flow velocity is 10m³/h, then the indicated value on the flow meter is 11m³/h. When installing, moving, or changing transducers it is advised the zero point be checked and or adjusted.

Adjust zero point using M42. But the zero point value after adjusting is only stored in RAM parameter area temporarily, is not solidified, or stored in FLASH. If the spare battery is off or choosing the solidification parameters in FLASH as work parameters when power on, the zero point value will be lost. In order to keep the zero point value

forever, users must use M.2 to store the zero point after adjusting zero point for each time.

§3.1.5 Full Scale Flow factor storage

Use M.1 to configure the full scale factor.

§3.1.6 Validating meter function.

Entering a pipe diameter of zero, results in the display to show the flow velocity: 1.2345678m/s (4.0504ft/s), flow rate=0, and display “R”status. Inputting a set value in M44 will change the totalizer output. Use this function to test the flow meter and network software without having to connect the transducers.

§3.1.7 Analog input interface as digit input interface method and introduction

The analog input interface can work as a digital input interface, but note that the loop input current should not be over 20 mA. When the output voltage is 5V, you must connect a 1k resistor in the return circuit. If the digital quantity voltage is 12V, then connect a 2k resistor.

§3.1.8 Serial Peripheral interface, SPI, 4-wire

Serial peripheral interface, SPI, is much like the USB interface, it features input, output, power supply, power supply-. It can be used to read flow, heat flow, positive total, 4-20mA value, frequency value and printing data etc. Different models can download using 4800 baud rate.

§3.1.9 Fluid Medium configuration function

For applications where the fluid mixture is oil and water the lower limits, to judge the medium in pipe is water or oil, you could input a lower limit of water flow in M+6, it is 1400m/s for this example. When the fluid flow velocity measured by the flow meter is lower than 1400m/s, an internal signal created, used to indicate that the fluid is another medium. This signal can be output by OCT or read by MODBUS protocol. Ensure that the two fluid flow velocities will not overlap.

§3.2 T Restore to factory defaults

If users want to clear all set parameters to restore original factory default, only use serial port or parallel port keyboard to enter M37 to click <•><◀>, so can restore default set parameters when they left the factory.

Attention: You will not want to invoke this function and is normally only invoked if you wish to “Start Over” and recommission the meter..

4. Transducer installation

§4.1 Unpacking

Check that the electronics enclosure was not damaged in transportation. If it was please take photos of the shipping crate and file a claim with the shipping company and contact Tactical Flow at 831-455-0418 and/or email to Dave@TacticalFlowMeter.com

§4.2 Power supply and transducer cables

Standard meters are shipped and require the use of a 24 VDC power supply capable of providing 500mA max. Universal AC power supplies for 85 to 236 VDC are also available.

Transducers signal cables require the use of high frequency special shielded twisted pair cables. Do not use coaxial shielded radio frequency cable or poor quality twisted pair cables, use the provided factory cables only.

§4.3 Installation Requirements

Choose clean sections of the pipe to install the transducers on the pipe after the mounting area is cleaned of paint or rust and place a “toothpaste amount” of the Coupling Grease directly on the transducer element so that when installed the grease barely oozes out. Then, secure the transducers firmly as indicated above.

§4.3.0.1 Coupling Grease Specifications:

We suggest the use of Dow Corning Product Name: MOLYKOTE™ BR-2 Plus High Performance Grease

This material is designed to remain in a gel like form to increase the acoustic coupling of the ultrasonic transducers to the pipe. This material works from -57 to 204 Degrees C which is above the specs of the transducers.

Dow Corning® 111 Valve Lubricant & Sealant

- **Primary Use** – General purpose O-ring and valve lubricant.
- **Special Characteristics** – Provides a noncuring moisture barrier; high dielectric strength; moisture and ozone resistance; good thermal, oxidation and chemical stability; suitable for use with potable water under NSF 61.
- **Physical Form** – Heavy-consistency, translucent white, grease-like silicone paste.
- **Applications** – Lubricating plug, sanitary, gate, ball, butterfly and automated valves, pump packings, rubber and plastic O-rings; sealing vacuum and pressure systems (especially equipment subjected to washing and harsh environments); damping medium for dash pots in electrical equipment.
- **Temperature Range** – From -40 to 400°F (-40 to 204°C).
- **Listings/Specifications** – FDA 21 CFR 175.300, NSF 51, NSF 61.
- **Container Sizes** – 

In a "pinch" one could use KY Jelly from the drug store however it is runny. The goal is to have a material that will not have bubbles in it and provides good sonic coupling. Air bubbles are the "enemy" of ultrasonic transducers. Using traditional Silicone sealant, such as that used for sealing windows, could also be used in an emergency but you MUST assure there are no air bubbles. This material could interfere with the signal quality, which is why we suggest the Dow 111.

§4.3.1 Choosing the ideal measurement point

To ensure the best measurement accuracy and stability, the installation point for the two transducers should be on a straight section of pipe that will always be filled with liquid and evenly distributed. Ultrasonic meters do not perform well when there is a swirl component. The following guidelines will assist in the best installation.

1. The pipe used to measure the flow must always be full of uniflor flow liquid and allows unobstructed transmission of the ultrasonic beam (either in vertical pipes or horizontal pipes)

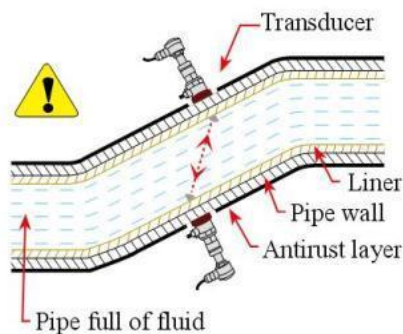

2. The upstream transducer should be installed where the upstream length of the straight section of pipe is at least 10D and the downstream pipe disturbance is at least 5D past where the downstream transducer is installed. The pipe length should be straight without any valves, pumps, angle bends. The installation point should be located away from valves, pumps, high pressure current, vibration, transformers, or any other electrical or mechanical interference source, etc.

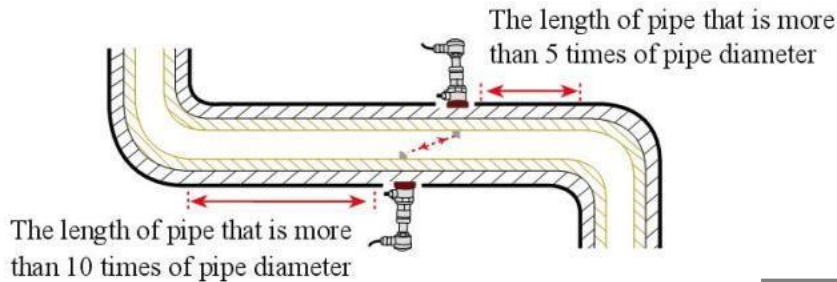

3. Avoid installations at the highest point of the piping system or vertical pipe with free exit (flow down)

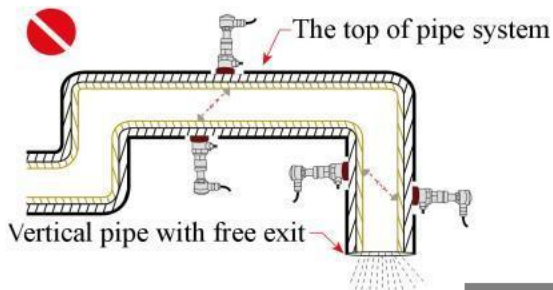

4. For locations with the flow exiting to ambient conditions the transducers should be installed on a U section of the pipe.

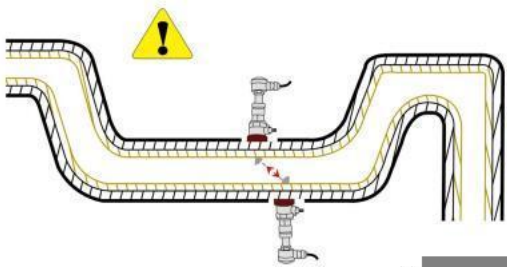

5. The temperature and pressure on the installation point should be within the specifications of the transducers.

6. In installations where there may be scaling inside the pipe consider scaling as a liner and input values that reflect the scaling material as if it were a liner. This will allow the meter to attain a better measurement.

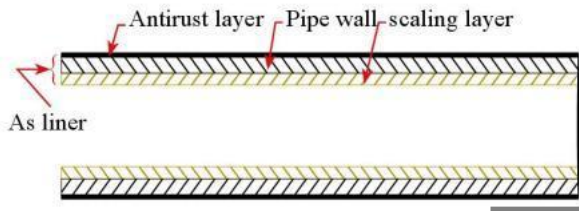

7. The two transducers must be installed in the horizontal direction to the pipe axis plane, within $\pm 45^\circ$ of the axis line horizontal plane. This is to prevent bubbles and to provide geometry so no sedimentation will be in the measurement path.

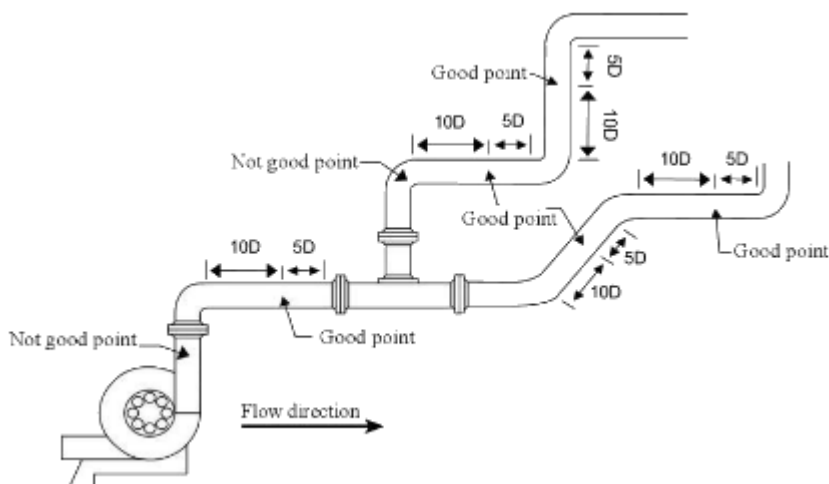
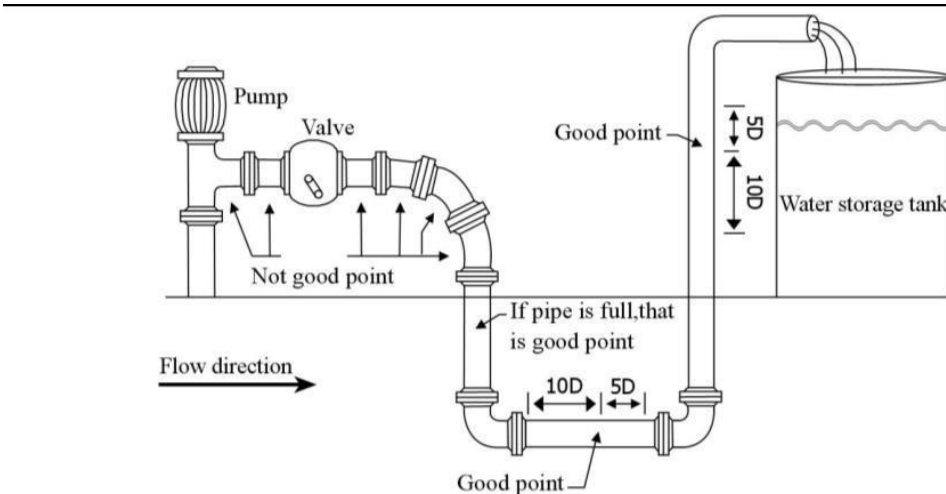

§4.3.2 instrument installed in instrument wells or vault requirements

When installing transducers in instrument wells or vaults, be sure to provide enough room for people to work. The distance between the pipe wall and well wall should be at least 24", and the width should be more than $(D''+24''*2)$. Cement pipe installations should be more than $(D''+28''*2)$. instrument well axial width L is more than $D+48''$. When installing transducers, avoid the place of flange, welding line, reducing, do best to install transducers in the range of $\pm 45^\circ$ of horizontal position of pipe axis. See the figure below.

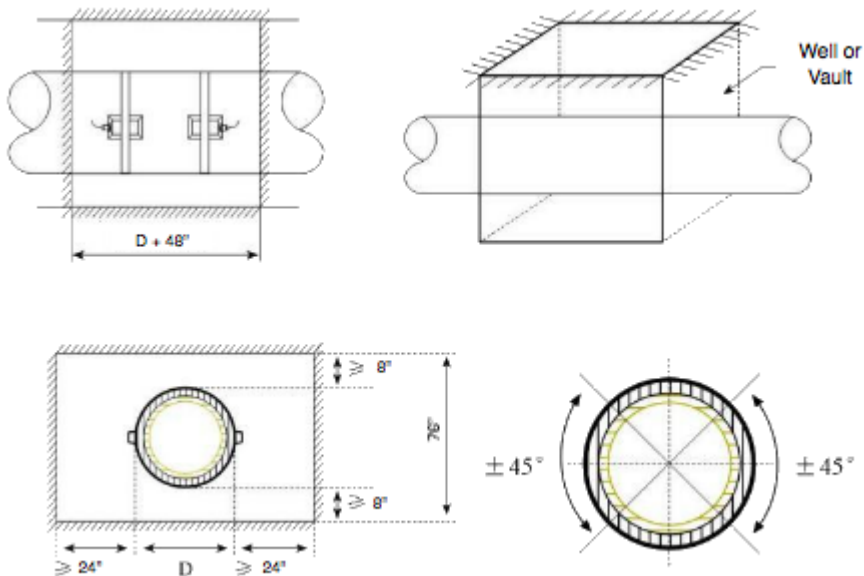

Important Notes:

1. Install transducers within $\pm 45^\circ$ of the horizontal axis position.
2. Connect the electronics enclosure to safety ground.
3. Do not install transducers on weld lines, dents, or curved surfaces..
4. Install transducers for easy access and maintenance.





§4.4 input pipe parameters:

1. Input pipe outer diameter

2. Input pipe wall thickness
3. Input pipe material
4. Input liner parameter (if the pipe has a liner, then include liner thickness and liner sound velocity)
5. Input fluid type
6. Input transducer type (Electronics can support over 20 types of transducers)
7. Input transducers installation configuration
8. Input solidification, or storage, parameter choices

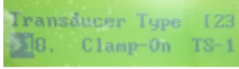
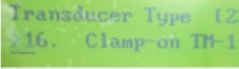
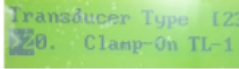
§4.5 Clamp on transducer installation

Clean the selected transducer installation area and be sure to remove any rust, paint, and even any anti-rust layers, We suggest using an angle grinder to polish the area. After polishing and cleaning use a cleaning cloth with alcohol or acetone to remove oil and dust, using the supplied tube of couplant and be sure to coat enough couplant around the center of the installation area. Attach the transducers on the pipe and ensure there are no air bubbles or particulates of any kind between the transducers and pipe wall. Tighten the bands to secure the transducers firmly.

Use Menu 23 to select Transducer Type as TS-1(.6"-4"), or TM-1 (4"-27"), or TL-1 (11"-228")			
Screen			
Transducer			
Transducer Code	TS-1	TM-1	TL-1
Transducer Type	TS-1	TM-1	TL-1
Ultrasonic Frequency	1 MHz		
Pipe Diameter Ranges	0.6" - 4.0"	4" - 27.0"	11" - 228" (19')
Dimensions	1.8" x 1" x 1.13"	2.5" x 1.5" x 1.7"	3.8" x 2.1" x 2.1"
Fluid Temperature	-22 F- 200F -30 C- 90 C	-22 F- 200F -30 C- 90 C	-22 F- 200F -30 C- 90 C
Weight	7 Oz	10 Oz	20 Oz

§4.5.1 Sensor Installation spacing

Installation space for a clamp on type transducer is measured between the two inner edges. This is the distance between the two transducers (face to face). These values are entered in M25.

§4.5.2 Installation method

There are two commonly used installation methods, the V method and the Z method

Normally, V method is utilized for pipe diameters within the range: ½" - 4" or DN15-DN200mm. If using the V method results in a poor signal we suggest using the Z method that is normally utilized for diameters greater than 8" or DN200mm or when measuring flow in cast iron pipes.

For the V Method use the figure below as a guideline and horizontally align the two transducers. Note the center line is horizontal with the pipe axis line. This method is suitable for pipe diameters in the range of ½" - 16" or DN15mm-DN400mm. This method is considered a reflected mode.

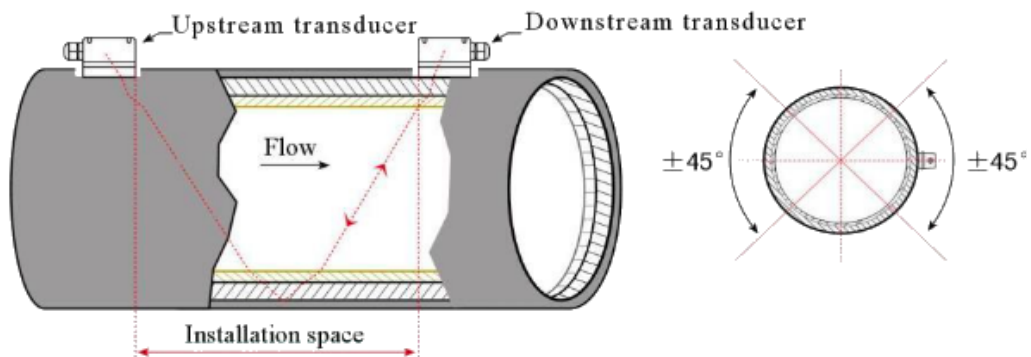

Use the Z method for large pipe diameters and where there may be suspended particulate or scaling. This method is ideal because the transducers transmit directly to each other without the reflection mode utilized in the V method. This method is known as the single sound path method.

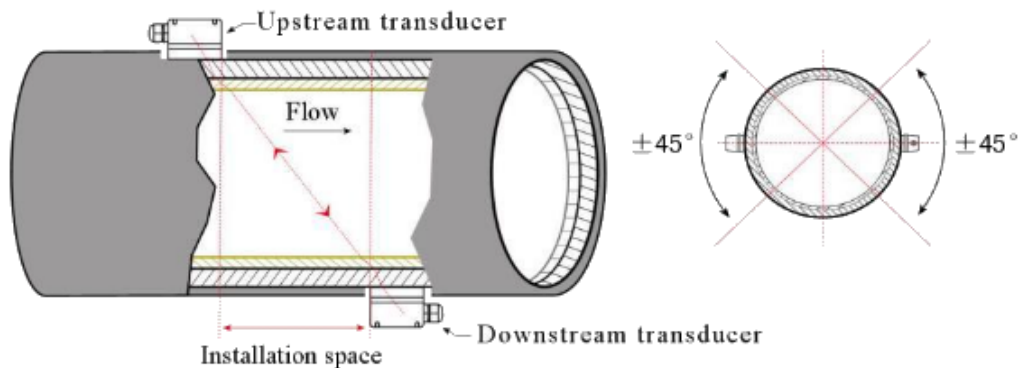

Important Notes:

1. Ensure transducers are installed on bare metal.

2. Ensure the shielded sensor cables are installed to the electronics in the correct polarity. Positive is RED and negative is BLACK.
3. Ensure cable entries are sealed to prevent the ingress of water and particulates.
4. Ensure transducers are secured and the wires are sealed from ingress of water.
5. Ensure stainless steel bands are affixed to the center of the transducers and are securely tightened so that one can not move them with their fingers.
6. Ensure that enough of the couplant has been applied so that transducers touch the pipe directly to prevent air, dust, water, or rust, that would degrade the beam from properly transferring the ultrasonic energy into the fluid stream.
7. After installation, enter M26 to solidify or store all the parameters. Cycle the power and check the variables are correct.

5.Troubleshooting

Diagnostics are displayed right corner of the menu window via an identification code detailed in Table 2. The user may view all the existing errors using function M08. Note the Hardware self-diagnosis is performed every time power is cycled.

Some errors may be detected during normal operation. Typically these errors are the result of an incorrect setup.

There are two types of errors the user can see on the display. Hardware errors are indicated by an F in the upper left corner of the screen and can be identified in Table 1. The other type of error refers to measurements indicated in Table 2. i

Table 1. Hardware self-diagnosis errors and solutions after power on

LCD display information	Causes	Solution
ROM verification Error	* ROM operation illegal / error	* Contact the manufacturer.
Logger reading error	* Stored parameters are wrong	* Cycle power /contact the manufacturer.
System logger error	* System stored data area has SEEOR	*Cycle power/contact the manufacturer.

Measuring circuit Hardware error	* Sub-CPU circuit errors	*Cycle power/contact the manufacturer.
CPU clock speed error	* System timer has errors	* Cycle power /contact the manufacturer.
Date time error	* System date and Time are wrong	* reset date and time
No Display. Erratic or Abnormal Operation	* Problem with wiring	* check wiring connections. No influence of measuring normally
No response to key presses	* Keypad is locked * Bad plug connection	* input password to unlock keyboard, or check wiring connections, no influence of measuring normally

Table2. Working status error code causes and solutions

code	M08 displaying	causes	solutions
*R	system work normally	* normal system	
*J	Circuit Hardware Error	* Hardware problem	* Contact the manufacturer
*I	No Signal	* Unable to receive signal * Loosen contact or not enough couplant between transducer and pipe surface. * Transducers installed improperly * scaling on inner pipe wall is too thick * new changed liner	* Make sure the transducer is in tight contact with the pipe surface, the couplant is enough. * Polish the pipe surface and clean the pipe surface. Clear paint, rust.

			<ul style="list-style-type: none"> * Check original installation parameter settings. * Clear the scaling or change the pipe with thick scaling, normally change to another measurement point that has little scaling, the meter can work normally. * Wait until the liner has been settled and then test.
*H	lower signal strength received	<ul style="list-style-type: none"> * lower signal * causes are the same with code "I" 	solution are the same with code "I"
*H	Poor signal quality received	<ul style="list-style-type: none"> * poor signal quality * include above all caused 	* include above all solutions
*E	The current of loop is over 20mA (not influence the measurement if not using current output)	<ul style="list-style-type: none"> * 4-20mA current loop output overflow 100% * Improper settings for current loop output 	* Check current loop settings on M56. or confirm if the actual flow rate is too high.
*Q	Frequency output is over the set value (not influence the measurement if not using frequency output)	<ul style="list-style-type: none"> * 4-20mA current loop output overflow 100% * Improper settings for current loop output 	* Check frequency output settings (refer to M66-M69) or confirm if the actual flow rate is too high.
*F	Listed in table 1	<ul style="list-style-type: none"> * find problems when power on and self-diagnosis * permanent hardware errors 	* power on again, check the information shown on screen, handled

			according to table 1, if not solved, contact the manufacturer. * contact manufacturer.
*G	Adjusting Gain >S1 Adjusting Gain >S2 Adjusting Gain >S3 *G Adjusting Gain >S4 (displayed on M00, M01, M02, M03)	Instrument is in the process of adjusting the gain to prepare the measurement. If stopped at S1 or S2 or switched between S1 and S2, that means the lower receiving signal is too low or on the ultrasonic signal can not send a measurable wave.	
*K	Empty pipe, setup in M29	no liquid in pipe or wrong setup	if there is liquid actually, input 0 value in M29

Note: the codes of *Q and *E displays do not affect measurement, only means current loop and frequency output have problems.

6.Warranty and service

§6.1 Warranty

The products are warranted to be free from defects in materials and workmanship for a period of two years from the date of shipment to the original purchaser. Our obligation is limited to restoring the meter to normal operation or replacing the meter, at the choice of the factory, and will be conditional upon receiving written notice of any alleged defect within 10 days after its discovery. We will determine if the return of the meter is necessary. If it is, the user is responsible for the one-way shipping fee from the customer to the manufacturer.

Transportation: buyers are responsible for the freight from our factory to destination.

§6.2 Maintenance Service

For operational problems, please contact Tactical Flow Meter technical support department by telephone, or email. In most cases, problems can be solved immediately. Refer to the Ultrasonic web page for videos on how to deal with common questions and installation tips. For any hardware failure of the instrument, we recommend our customers send it in for service. Please contact the technical support department with

the model number and serial number of the unit before sending the unit back to us. Both numbers can be found on the product label. For service or calibration requests, we will issue a Return Materials Authorisation (RMA) number. Take note that the cost for repairing can only be determined after receipt and inspection of the instrument. A quotation will be sent to the customer before proceeding with the service. Normally, buyers are responsible for the transportation of meters and freight.

§6.3 Software Update Service

We provide free-of-charge software update services. Please contact the factory to determine if your meter may benefit from a software update.

§6.4 Important Notice for Product Return

Before returning the instrument for warranty repair or service, please read the following carefully:

1. if the return item has been exposed to nuclear or other radioactive environment, or has been in contact with hazardous material which could pose any danger to our personnel, the unit cannot be serviced.
2. if the return item has been exposed to or in contact with dangerous materials, but has been certified as hazard-free device by a recognized organization, you are required to supply the certification for the service.
3. if the return item doesn't have a RMA# associated, it will be sent back without any service conducted.

§7.0 Wiring info

The drawing below shows the wiring layout.

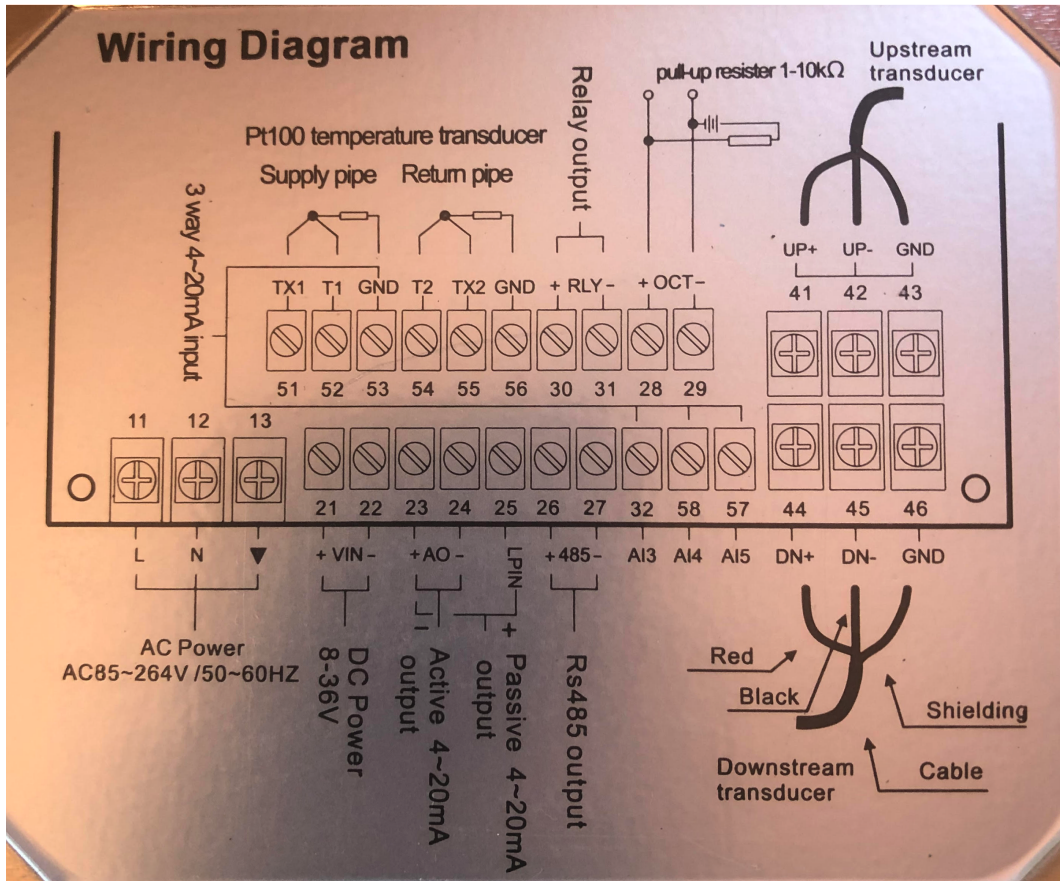

Notice DC Power on terminals 21 & 22

NOTE: The power can be EITHER 8-36 VDC on pins 21 & 22 or you may use an AC power of 55-264 VAC at 50/60 Hz. You must NOT connect BOTH.

§8.0 Electronics Enclosure dimensions

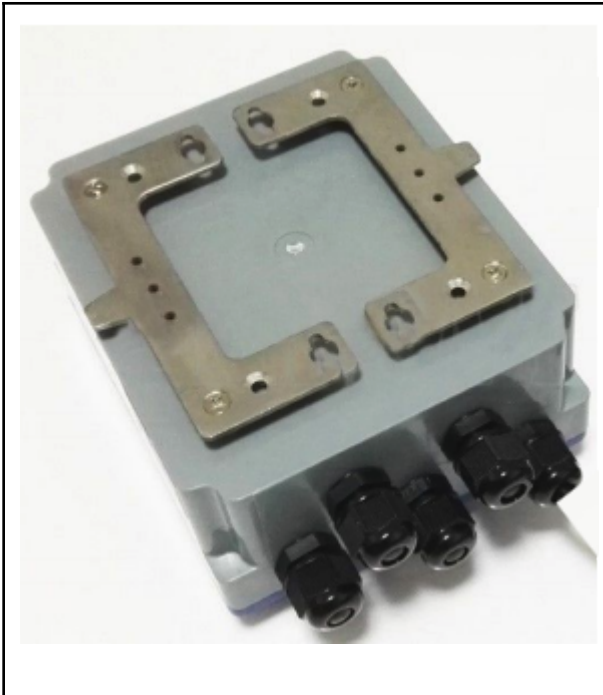
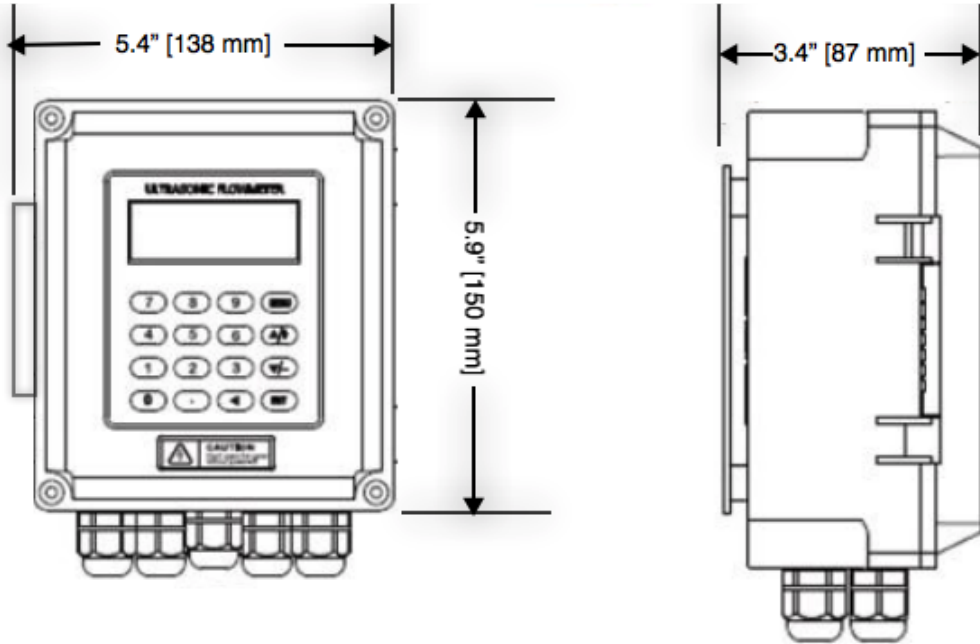

Keyhole array 3.67" x 0.95" [93 mm x 23 mm] for 0.152 max screw OD to pass 0.312 head.

§8.0 Digital Communication

Registers

The TDS-100M Ultrasonic Flow Meter supports three different communication protocols; MODBUS, Fuji Extended Protocol, and the Easy-to-Use Water Meter Protocol

Additionally, both the RTU and the ASCII format of MODBUS is supported

The Fuji Extended Protocol is developed based on the protocol used in the Fuji Japanese ultrasonic flow meters for compatibility with our enhanced Ultrasonic Flow Meters.

The hardware allows a MODEM to be connected directly to the RS232 port to make it easy to set up a flow SCADA by means of PTN. With the RS485 port, TDS-100M can be connected to a network based on the MODBUS protocol using RS485. With use of a GSM module, flow data can be read by the use of a mobile phone.

The programmable device address (ID number), or Slave ID, located at window M46, to allow the flow meter to be addressed with a SCADA system. If there are more than two flow meters are used in a network, the prefix W must be used before every command.

When TDS-100M is used in a network, all the parameters of the flow meter can be programmed through the network, except the device address, Slave ID, that must be entered on the local keypad using Window 46.

TDS-100M supports MODBUS functions code 3 and code 6, i.e. reading and writing registers.

For example, reading the registers from REG0001 to REG0010 in the unit #1, or Slave ID 1, (ultrasonic flow meter) using the MODBUS-RTU format, the command is as follows:

Example for reading 10 registers starting at Reg 00

01	03	00 00 00	0A	C5 CD
Slave ID	Function Code	Reg Start	# of Regs	Check-Sum

Using MODBUS-ASCII format, the command is:

:0103000000AF2(CR and LF)

By default, the RS232/RS485 is configured as:

9600,none,8,1(9600bd,none parity,8 data bits,1 stop bit)

§8.1 ModBus Register listing

REGISTER #	VARIABLE NAME	FORMAT	NOTE
0001-0002	Flow Rate	IEEE-754	
0003-0004	Energy Flow Rate	IEEE-754	
0005-0006	Velocity	IEEE-754	
0007-0008	Fluid sound speed	IEEE-754	
0009-0010	Positive accumulator	LONG	
0011-0012	Positive decimal fraction	IEEE-754	
0013-0014	Negative accumulator	LONG	
0015-0016	Negative decimal fraction	IEEE-754	
0017-0018	Positive energy accumulator	LONG	In GJ
0019-0020	Positive energy decimal fraction	IEEE-754	In GJ, float
0021-0022	Negative energy	LONG	In GJ

	accumulator		
0023-0024	Negative energy decimal fraction	IEEE-754	In GJ, float
0025-0026	Net accumulator	LONG	In GJ
0027-0028	Net decimal fraction	IEEE-754	
0029-0030	Net energy accumulator	LONG	In GJ, float
0031-0032	Net energy decimal fraction	IEEE-754	In GJ, float
0033-0034	Temperature #1/inlet	IEEE-754	
0035-0036	Temperature #2/outlet	IEEE-754	
0037-0038	Analog input AI3	IEEE-754	
0039-0040	Analog input AI4	IEEE-754	
0041-0042	Analog input AI5	IEEE-754	
0043-0044	Current input at AI3	IEEE-754	units of mA
0045-0046	Current input at AI3	IEEE-754	units of mA
REGISTER #	VARIABLE NAME	FORMAT	NOTE
0047-0048	Current input at AI3	IEEE-754	units of mA
0049-0050	System password	BCD	Writable 00H for
51	Password for hardware	BCD	Writable "A55Ah" for
0053-0055	Calendar (date and time	BCD	Writable 6 Bytes of
56	Day+Hour for Auto-Save	BCD	Writable For example
59	Key to input	INTEGER	Writable
60	Go to Window #	INTEGER	Writable
61	LCD Back-lit lights for	INTEGER	Writable units of
62	Times for the beeper	INTEGER	Writable Max 255
62	Pulses left for OCT	INTEGER	Writable Max 65535
72	Error Code	BIT	16 bits, see note 4
0077-0078	PT100 resistance of inlet	IEEE-754	units of Ohm
0079-0080	PT100 resistance of outlet	IEEE-754	units of Ohm
0081-0082	Total travel time	IEEE-754	units of Microsecond
0083-0084	Delta travel time	IEEE-754	units of Nanosecond

0085-0086	Upstream travel time	IEEE-754	units of Microsecond
0087-0088	Downstream travel time	IEEE-754	units of Microsecond
0089-0090	Output current	IEEE-754	units of mA
92	Working step and	INTEGER	The high byte is the step and low for signal quality, range 00-99, the larger the better.
93	Upstream strength	INTEGER	Range 0-2047
94	Downstream strength	INTEGER	Range 0-2047
96	Language used in user interface	INTEGER	0 : English, 1:Chinese
0097-0098	Rate of measured travel time	IEEE-754	Normal 100+-3%
0099-0100	Reynolds number	IEEE-754	
0101-0102	Pipe Reynolds factor	IEEE-754	
REGISTER #	VARIABLE NAME	FORMAT	NOTE
0103-0104	Working Timer	LONG	unsigned, in second
0105-0106	Total working time	LONG	unsigned, in second
0105-0106	Total power on-off time	LONG	unsigned
0113-0114	Net accumulator	IEEE-754	In Cubic Meter, float
0115-0116	Positive accumulator	IEEE-754	In Cubic Meter, float
0117-0118	Negative accumulator	IEEE-754	In Cubic Meter, float
0119-0120	Net energy accumulator	IEEE-754	In GJ, float
0121-0122	Positive energy accumulator	IEEE-754	In GJ, float
0123-0124	Negative energy accumulator	IEEE-754	In GJ, float
0125-0126	Flow for today	IEEE-754	In Cubic Meter, float
0127-0128	Flow for this month	IEEE-754	In Cubic Meter, float
0129-0130	Manual accumulator	LONG	
0131-0132	Manual accumulator decimal fraction	IEEE-754	
0133-0134	Batch accumulator	LONG	

0135-0136	Batch accumulator decimal fraction	IEEE-754	
0137-0138	Flow for today	LONG	
0139-0140	Flow for today decimal fraction	IEEE-754	
0141-0142	Flow for this month	LONG	
0143-0144	Flow for this month decimal fraction	IEEE-754	
0145-0146	Flow for this year	LONG	
0147-0148	Flow for this year decimal fraction	IEEE-754	
158	Current window	INTEGER	
0165-0166	Failure time	LONG	unit in seconds
0173-0174	Current output frequency	IEEE-754	
REGISTER #	VARIABLE NAME	FORMAT	NOTE
0175-0176	Current output with 4-20mA	IEEE-754	
0181-0182	Temperature difference	IEEE-754	
0183-0184	Lost flow	IEEE-754	
0185-0186	Clock coefficient	IEEE-754	Should less than 0.1
0187-0188	Total time for Auto-Save	IEEE-754	Time to save by 0056
0189-0190	POS flow for Auto-Save	IEEE-754	Time to save by 0056
0191-0192	Flow rate for Auto-Save	IEEE-754	Time to save by 0056
0221-0222	Inner pipe diameter	IEEE-754	In millimeter
0229-0230	Upstream delay	IEEE-754	In microseconds
0231-0232	Downstream delay	IEEE-754	In microseconds
0233-0234	Calculated travel time	IEEE-754	In microseconds
0257-0288	LCD buffer	BCD	
289	LCD buffer pointer	INTEGER	
311	Worked time for today	LONG	Unsigned, in seconds
313	Worked time for this month	LONG	Unsigned, in seconds
1437	Unit for flow rate	INTEGER	See note 5

1438	Unit for energy totalizer	INTEGER	0=GJ 1=Kcal
1439	Multiplier for accumulator	INTEGER	Range 0~7
1440	Multiplier for energy accumulator	INTEGER	Range 0~10
1441	Unit for energy flow rate	INTEGER	0=GJ/h , 1=Kcal/h
1442	Device address	INTEGER	
1451	User scale factor	IEEE-754	
1521	Factory scale factor	IEEE-754	Read only
1523	Multiplier for accumulator	INTEGER	
1524	Multiplier for energy accumulator	INTEGER	
1525	Energy accumulator Units	INTEGER	
1529	Serial number	BCD	High byte first

Note: 947,817 BTU = 1 GJ

Configure Energy Meter with Menu 84 and view Energy with Menu 5

§8.2 Factory Contact Information

Take 5, Inc. DBA Tactical Flow Meter

22642 Indian Springs Road

Salinas, CA 3908

(831)-455-0418

Dave@TacticalFlowMeter.com

<https://www.tacticalflowmeter.com/>