



375 D

OWNER'S MANUAL





Comfort Zone #1: Comfortable Cabin Heat.

Get heat where you want it, when you want it! Because the Aqua-Hot system heats by zones, your bedroom, living room, and bathroom can be custom temperatures. And don't hesitate to crank up the heat, because the Aqua-Hot system doesn't remove moisture from the air. From now on, you will have to blame the dry skin and itchy eyes on Mother Nature!

Comfort Zone #2: Quiet Operation

Say goodbye to rude awakenings from the forced air furnace, you're an Aqua-Hot owner now! The Aqua-Hot is quiet when operating, so you'll never have to turn up the TV, yell across the room, or have an interrupted night of sleep again due to your heating system.

Comfort Zone #3: Continuous, On-Demand Hot Water

Take long, guilt free showers knowing there is no recovery time for the next shower or load of laundry. The freedom to take a shower when you want makes your RV experience feel much more like home.

Comfort Zone #4: Low Emissions

Aqua-Hot's new low emission systems are fumeless and odorless. It's good for you, good for your neighbor, and good for the environment.



Comfort Zone #5: Over 160 Factory-Trained Service Centers

You won't need to service your Aqua-Hot often, but when you do, you can be confident in our Certified Service Centers that are close by and trained to assist you with all of your Aqua-Hot specific needs.

Comfort Zone #6: Adds Value

The NADA Recreational Vehicle Guide lists Aqua-Hot as adding thousands of dollars to the value of an RV. That value will pay off when it's time to trade up or sell.

Comfort Zone #6: Low fuel Costs

There's no need to burn propane each time heat or hot water is needed. Aqua-Hot's TribridHot technology powers the Aqua-Hot system by pulling heat from one or a combination of heat sources. When shore power is available, simply plug it in. When dry-camping or in very cold conditions, use the Diesel Burner.

CAUTION:

Before welding or plasma cutting on any coach, it is necessary to disconnect the electric wiring to the Aqua-Hot System.

Failure to disconnect the wires from the Aqua-Hot System before using a welder or a plasma cutter on the coach may cause damage to the Aqua-Hot.

WARNING!

You must winterize the Aqua-Hot when freezing temperatures are present if the Aqua-Hot is turned off. This includes when the coach is being used and the electrical element and diesel burner switch are in the off position, or when the coach is in storage.

Not winterizing the Aqua-Hot when the aforementioned conditions are present will result in serious damage to the Aqua-Hot's Domestic Water Heating System, requiring complete system replacement not covered under the Aqua-Hot warranty.

Introduction

Introduction to the Aqua-Hot Hydronic Heating SystemPage 6

Operating Instructions

Activating the Aqua-Hot Heating SystemPage 8
 Zone Thermostat OperationPage 10
 Using the Domestic Water Heating SystemPage 10
 Aqua-Hot Operational Flow ChartPage 11

Maintenance

Monthly MaintenancePage 12
 Replenishing the Antifreeze and Water Heating SolutionPage 12
 Annual MaintenancePage 12

Winterization

Winterizing the Domestic Water Heating SystemPage 13
 De-Winterizing the Domestic Water Heating SystemPage 13

Troubleshooting

General InformationPage 14
 Diesel-Burner Blinking Fault Indicator lightPage 14

Appendices

Appendix A: Antifreeze TypesPage 14
 Appendix B: Antifreeze Mixture Water Quality RecommendationsPage 15
 Appendix C: Antifreeze Terms and Mixture RatioPage 16
 Appendix D: Measuring Propylene Glycol Using a RefractometerPage 18

Warranty

Limited Warranty StatementPage 21

INTRODUCTION

This manual should be maintained in legible condition and kept in a safe, easily-accessible location for future reference.

Please read the complete Owner's Manual prior to operating the Aqua-Hot Hydronic Heating System. Also, be sure to fill out and mail in the "Warranty Registration" card attached to this manual.

The Aqua-Hot Heating System is a Hydronic Heating System (heating with hot water) that provides interior zone heating where and when it is needed, as well as a continuous, on-demand supply of domestic hot water. Both heating features are accomplished by a 12 Volt-DC powered Diesel-Burner and a 120 Volt-AC powered Electric Heating Element, which maintain the temperature of the Aqua-Hot's antifreeze and water heating solution. Be sure to reference Figures 1-A through 1-C for a complete component overview.

NOTE: This Aqua-Hot product utilizes a propylene glycol based antifreeze and water heating solution. This propylene glycol based solution is a Boiler type antifreeze that is "Generally Recognized as Safe" (GRAS) by the FDA. For additional information regarding this "GRAS" antifreeze product, please reference Appendix A, contact the Aqua-Hot Heating Systems Technical Support Department at 1-800-685-4298, or visit the web site at www.aquahot.com.

Danger, Warning, Caution, and Note Boxes:

Danger, Warning, Caution, and Note boxes appear throughout this manual as a means of alerting the operator to important information.

⚠ DANGER! ⚠
INDICATES THAT PERSONAL INJURY IS LIKELY OR IMMINENT.

WARNING!
Indicates that serious damage to the heater will occur and personal injury is possible as well.

CAUTION:
Indicates that damage to the heater is possible.

NOTE: Indicates information that requires special attention by the operator.

Figure 1-A

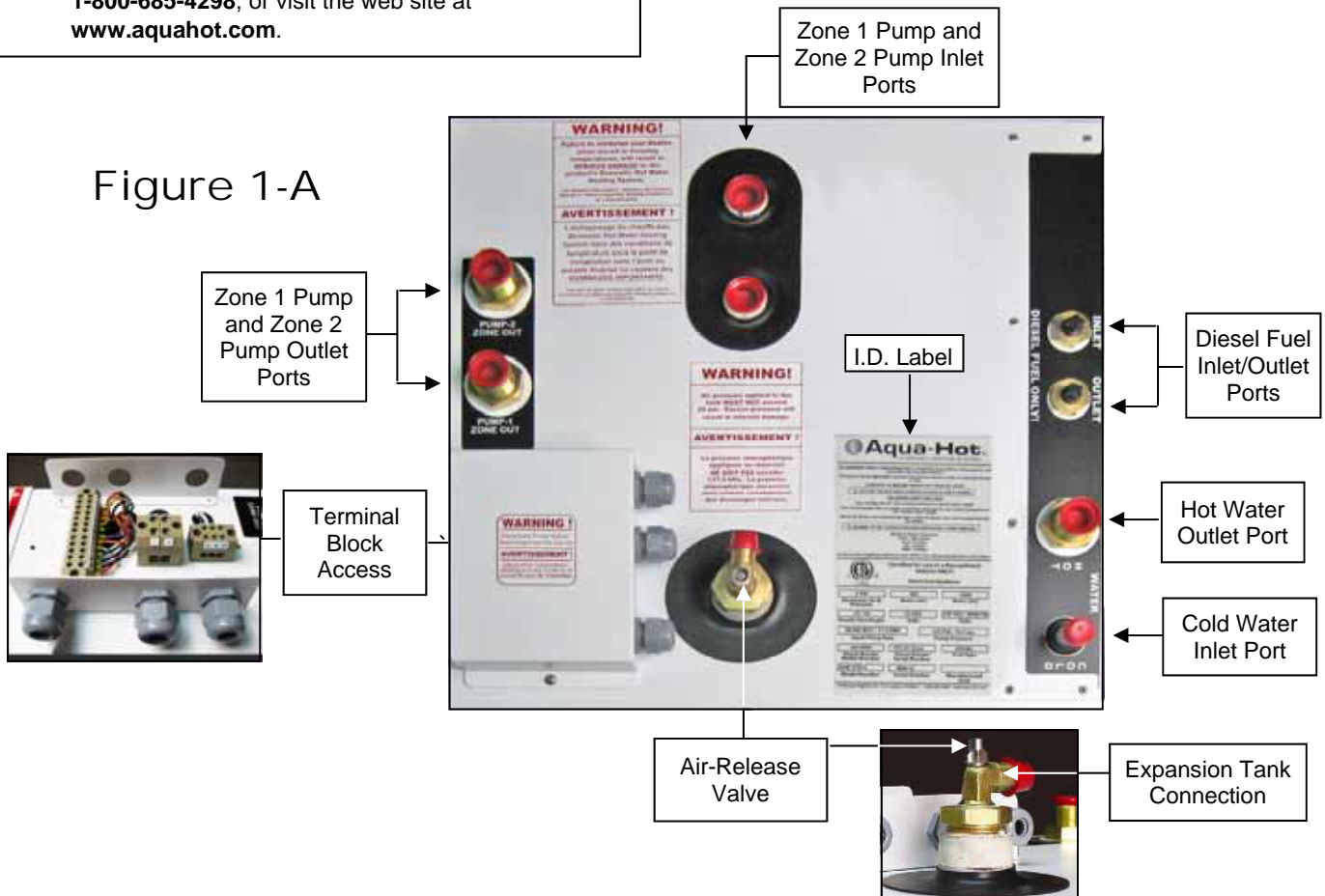
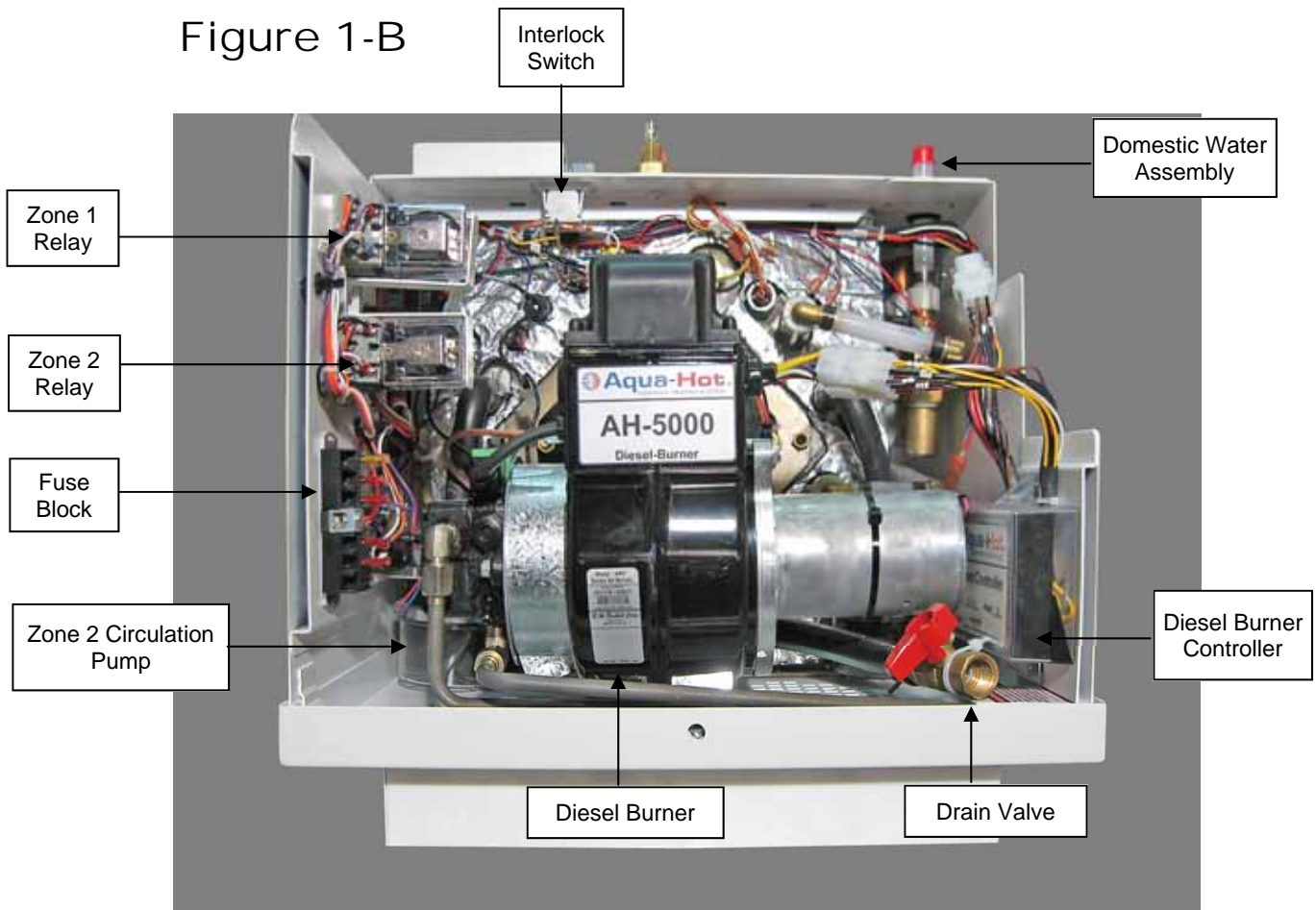

Figure 1-B



OPERATING INSTRUCTIONS

Aqua-Hot I.D. Label



HYDRONIC HEATING SYSTEM

For installation only in a compartment that is completely closed off from living quarters and accessible only from the outdoors.
The Exhaust System **MUST NOT** terminate beneath the vehicle or under an openable window or vent.
Combustion Air **MUST BE** supplied from outside the vehicle.

 CAUTION: THIS APPLIANCE OPERATES ON BOTH AC AND DC POWER.

USE COPPER CONDUCTORS ONLY!

Use a 25-Amp fuse for over-current protection for the DC power supply.
Use a circuit breaker that cuts power at 20-Amps maximum for over-current protection for the 120-VAC power supply.

Mount the Heater near a bay/storage door so that the Access Cover can be easily removed for service.

 WARNING: DO NOT OPERATE APPLIANCE WITH ACCESS COVERS REMOVED.

Minimum Heater Clearances:
 Front - Open Access
 Back - 0 inches
 Top - 0 inches
 Sides - 0 inches

Install in strict compliance with local codes, NFPA 1192, and the manufacturer's instructions.



Certified for use in a Recreational Vehicle ONLY!

Direct Vent Appliance

0 PSI	245	1500
Maximum Tank Pressure	Watts (DC)	Watts (AC)
.35 / 60	12 VDC	120 VAC, 50/60 Hz
Nozzle Size/Angle	Volts	Volts
59,000 BTU / 17.3 kWh	145 PSI / 10.0 bar	
Input Firing Rate	Pump Pressure	
AH-5000		DIESEL
Diesel-Burner Model Number	Diesel-Burner Serial Number	Fuel Type
AHE-375		
Model Number	Serial Number	Manufactured Date

15549 East Highway 52 • Fort Lupton, CO 80621 • 1.800.685.4298 • www.aqua-hot.com

Figure 2

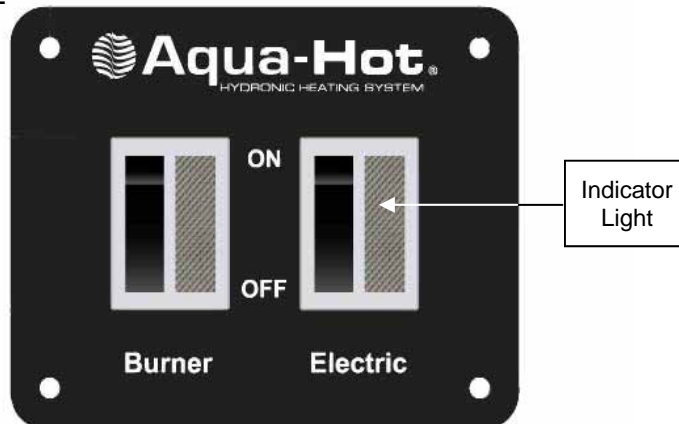

Figure 3

WARNING!

The Aqua-Hot's Exhaust is HOT!

DO NOT park in areas where dry conditions exist underneath the vehicle as a fire may result (i.e., in a dry, grassy field)!

DO NOT operate the Aqua-Hot's Diesel-Burner inside an enclosed building!

The Heater must be switched **OFF** when refueling.

CAUTION:

DO NOT operate the Diesel-Burner and/or Electric Heating Element without the antifreeze and water heating solution in the Aqua-Hot's Boiler Tank. Failure to do so will

Activating the Aqua-Hot Heating System:

Diesel-Burner:

Turn the Burner switch **ON**; reference Figure 3. This procedure will activate the Diesel-Burner and the indicator light located adjacent to the Diesel-Burner switch. Allow 10-20 minutes for the Aqua-Hot System to reach operating temperature. Please note that the Diesel-Burner is the **primary heat source** for heating both the interior and the domestic hot water (such as when cool ambient temperatures exist and/or when there is a high demand for domestic hot water).

Electric Heating Element:

Turn the Electric switch **ON**; reference Figure 3. This procedure will activate the 120 Volt-AC Electric Heating Element and the indicator light located adjacent to the Electric switch. Allow 1-2 hours for the Aqua-Hot System to reach operating temperature.

This page intentionally left blank

OPERATING INSTRUCTIONS

Zone Thermostat Operation

Interior Room Thermostat:

Simply adjust each Interior Room Thermostat to the desired temperature. Then, whenever an Interior Room Thermostat “calls for heat,” the Aqua-Hot’s Circulation Pump and Interior Heat Exchanger Fans will be activated. These devices, together, will supply warmth and comfort to each interior heating zone. The Aqua-Hot must be at operating temperature in order for the zones to function. Please contact the specific motorhome manufacturer for the exact location of the Interior Room Thermostats.

Fresh Water Tank Thermostat:

Simply adjust the Thermostat for Bay Heating to a minimum of 40°F. This will prevent freezing of the domestic water storage system. Please contact the specific motorhome manufacturer for the exact location of the Fresh Water Tank Thermostat.

Using the Domestic Water Heating System

When the Aqua-Hot is at operating temperature, the domestic water is automatically heated as it is being used. Because the Aqua-Hot does not store any hot water, simply open any hot water faucet and a continuous supply of domestic hot water will be present within a few seconds. This hot water feature is **continuous** and is accomplished by the Aqua-Hot’s Domestic Water Heating System. The Diesel-Burner switch on the Interior Switch Panel must be **ON** in order to obtain a continuous supply of hot water (e.g., during showers); be sure to also activate the Electric Element switch for **maximum** hot water capacity. Reference Figure 4.

NOTE: The Aqua-Hot’s “Domestic Water Priority System” disables the interior zone heating fans and the zone circulation pumps whenever domestic hot water is being used on a continuous basis (e.g., during showers). Once the demand for continuous domestic hot water ceases, the Aqua-Hot will enable the fans and the pumps to operate and provide heat to the Heating Zones.

NOTE: Both the Diesel-Burner and Electric Heating Element are thermostatically controlled. Either or both heating sources will automatically maintain the temperature of the Aqua-Hot’s anti-freeze and water heating solution between approximately 160°F and 190°F(±5). Therefore, to heat the motorhome/domestic hot water, simply choose the desired heat source(s) and leave the switch(es) (i.e., Diesel-Burner and or Electric Element) **ON**.

Figure 4

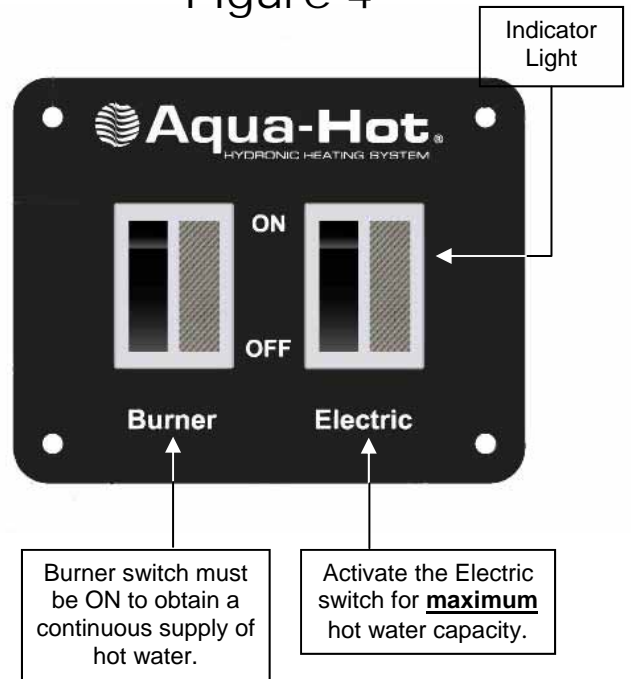

Aqua-Hot Operational Flowchart

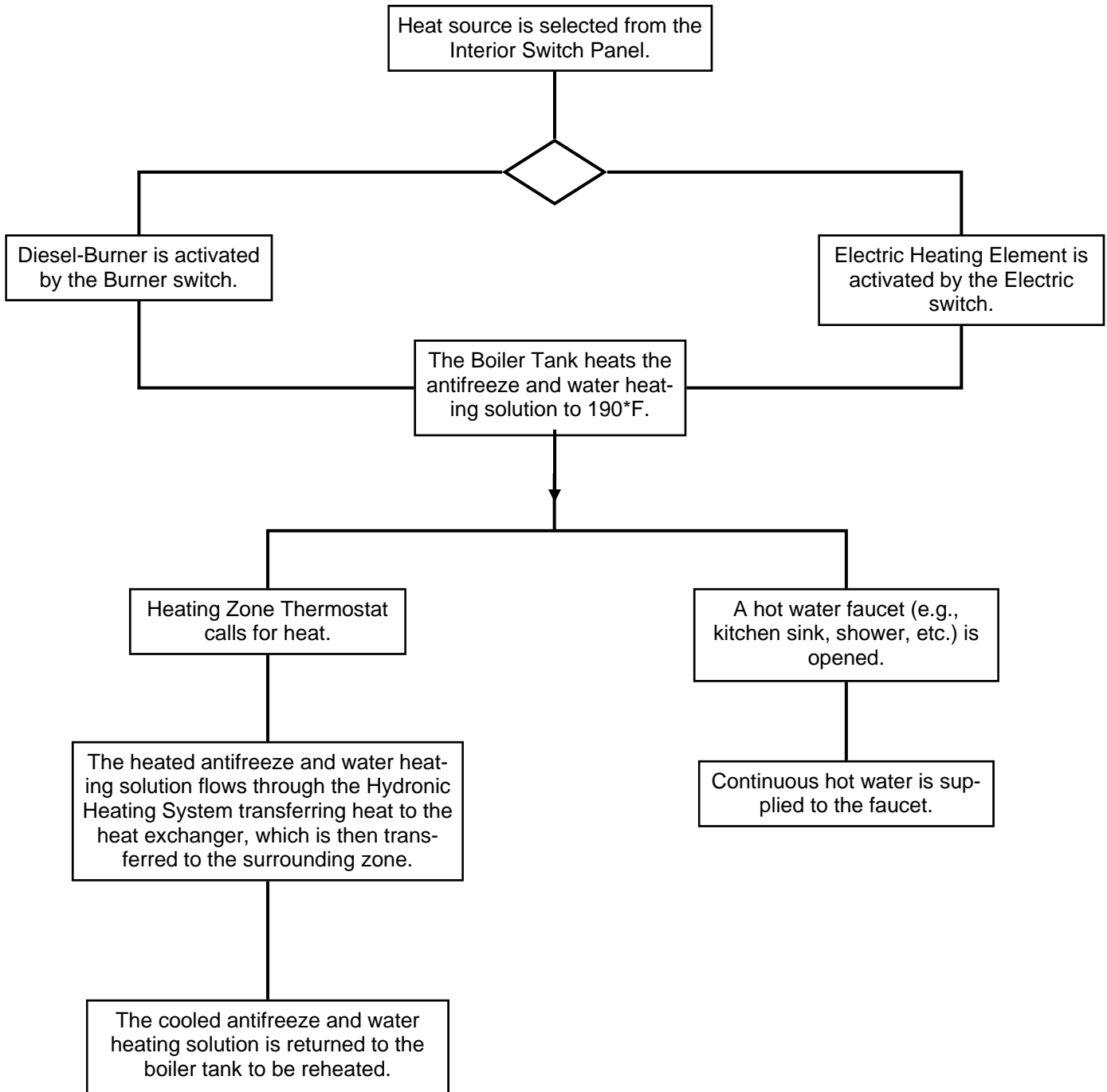

⚠ DANGER! ⚠

WHEN THE AQUA-HOT IS AT MAXIMUM OPERATING TEMPERATURE, THE COOLANT WILL BE VERY HOT! IF THE AQUA-HOT'S HEATING SYSTEM IS ACCESSED, SCALDING BY HOT VAPOR OR COOLANT COULD RESULT! BEFORE CLEANING OR SERVICING, DISCONNECT ALL POWER SUPPLIES!

WARNING!

DO NOT operate the Diesel-Burner and/or the Electric Heating Element without the antifreeze and water heating solution in the Aqua-Hot's Boiler Tank; doing so will cause serious damage to the Heater.

Propylene Glycol that is "Generally Recognized As Safe" by the FDA must be utilized for the antifreeze and water heating solution.

NOTE: For additional information regarding this propylene glycol-based, boiler-type antifreeze that has been "Generally Recognized As Safe" by the FDA, please reference Appendix A, contact Aqua-Hot Heating Systems Technical Support Department at 1-800-685-4298, or visit the Web

Annual Maintenance:

To keep the Aqua-Hot running smoothly, it is ideal to have the Diesel-Burner tuned-up annually. A tune-up should consist of a new Fuel Nozzle and Fuel-Filter; reference Figure 7. To ensure maximum Diesel-Burner performance, always use the recommended Fuel Nozzle and Fuel Filter when replacing these parts. Reference the Aqua-Hot's Service and Parts Manual for spare parts information and detailed replacement instructions, contact the Aqua-Hot Heating Systems Technical Support Department at 1-800-685-4298 for assistance or to locate the nearest Aqua-Hot Service Center, or visit the web site at www.aquahot.com.

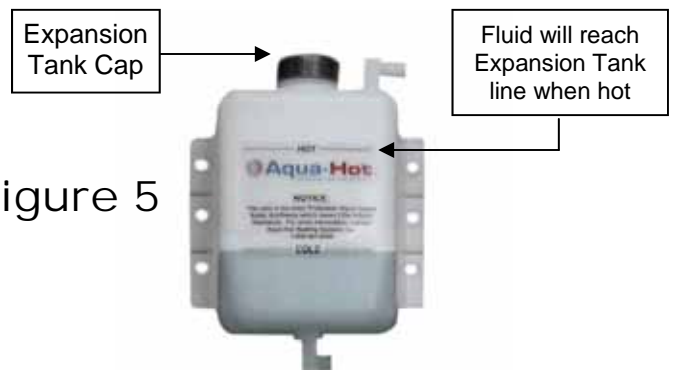

Figure 5

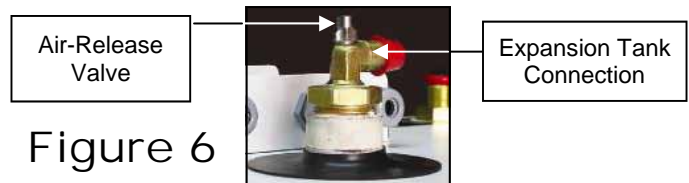

Figure 6

Maintenance Schedule

Monthly Maintenance:

Check the Aqua-Hot's antifreeze and water heating solution to ensure that it is at the proper level. This can be accomplished by visually checking the coolant level in the Aqua-Hot's Expansion Tank; reference Figure 5. Please note that the coolant level should be checked **only** when the Aqua-Hot is at maximum operating temperature (i.e., immediately after the Diesel-Burner cycles OFF). When maximum operating temperature, the antifreeze and water heating solution should be at the level marked "HOT" on the Expansion Tank.

Replenishing the Antifreeze and Water Heating Solution:

If the antifreeze and water heating solution needs replenishing, remove the Expansion Tank's cap and fill the Expansion Tank to the "HOT" level mark. When refilling, open the Air Release Valve located on the Expansion Tank Connection to release air pockets; reference Figure 6. Hold the valve open until all air is released. If necessary, refill the Expansion Tank again. Be sure the valve is closed when finished by hand-tightening. Reference Appendices A through C in order to determine the correct ratio of antifreeze to water, the proper type of antifreeze, and the water quality recommendations for the Aqua-Hot Hydronic Heating System's antifreeze and water heating solution.



Fuel Nozzle
Part Number:
FLX-013-150

Figure 7



Fuel Filter
Part Number:
FLE-120-100

WARNING!

Not winterizing the Aqua-Hot when freezing temperatures are present will result in serious damage to the Aqua-Hot's Domestic Water Heating System. Also, be sure to use an FDA approved, "GRAS" rated anti-freeze for winterization.

NOTE: The Aqua-Hot can continue to be used for interior zone heating once the domestic water heating system has been drained and winterized.

The Aqua-Hot's Domestic Water Heating System must be completely drained of domestic water any time the heater is stored where freezing temperatures may be experienced.

Winterizing the Domestic Water Heating System:

Please follow these instructions when winterizing the Aqua-Hot's Domestic Water Heating System; reference Figure 8:

1. Completely drain the fresh water storage tank.
2. Disconnect the domestic water demand pump's suction line from the fresh water storage tank.
3. Attach an adequate piece of hose onto the suction side of the domestic water demand pump.
4. Place the opposite end of the hose into an adequate supply of FDA-approved "GRAS" RV Antifreeze.

5. Open and close all interior and exterior water faucets, one at a time, until only pure RV Antifreeze is present. Perform this procedure for both the hot and cold faucets.
6. Remove the hose and reconnect the domestic water demand pump's suction line to the fresh water storage tank.

De-Winterizing the Domestic Water Heating System:

For de-winterization, completely fill the fresh water storage tank. Open and close all interior and exterior water faucets, one at a time, until only clear water is present/visible.

Reference Figure 8.

If disinfecting the potable water system after de-winterizing, be sure to follow RVIA's "Instructions for Disinfection of Potable Water Systems on Recreation Vehicles." These instructions can be obtained by contacting the Recreational Vehicle Industry Association at (703) 620-6003, visiting them online at www.rvia.com, or writing to them at the following address:

Recreation Vehicle Industry Association
 1896 Preston White Drive
 P.O. Box 2999
 Reston, VA 20195-0999

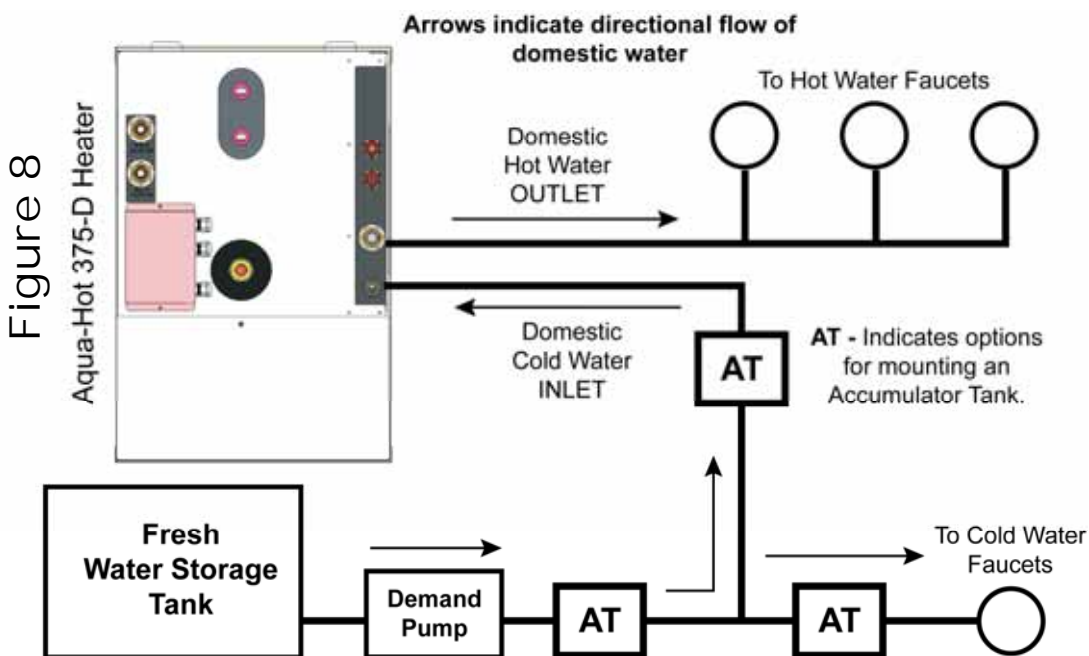

Remove the hose from the Fresh Water Storage Tank and attach an adequate piece of hose onto the suction side of the demand pump. Place this hose into a container of RV Antifreeze and allow this to pump through the Domestic Water System until the faucets run pure antifreeze.

TROUBLESHOOTING

General Information

Should the Aqua-Hot Hydronic Heating System fail to operate, complete the following checks:

1. Check the interior switch panel for blinking indicator light on the diesel-burner switch. If the indicator light is blinking, count the number of consecutive flashes and contact the Aqua-Hot Heating Systems Technical Support Department at **1-800-685-4298**.
2. Verify that the Aqua-Hot's access cover is securely installed. The Aqua-Hot Hydronic Heating System will not operate if the access cover is not fully installed.
3. Ensure that the main diesel tank contains a sufficient level of diesel.
4. Ensure that the Aqua-Hot's boiler tank has an adequate supply of antifreeze and water heating solution by checking the level at the expansion tank. If the level is low, reference the maintenance section of this manual for refilling instructions.
5. Verify that the wires attached to the ground strip are firmly attached; reference Figure 1-B.

If the Aqua-Hot Heating System's failure to operate is not resolved with the aforementioned checks, please contact the Aqua-Hot Heating Systems Technical Support Department at **1-800-685-4298** for additional assistance or visit the web site at www.aqua-hot.com

Diesel-Burner Indicator Light

The Interior Switch Panel incorporates a self-diagnosing blinking fault indicator light, which by using a series of blinking lights, indicates the particular component of the diesel-burner that failed during operation,

Each series of blinks is active for 0.5 seconds "ON" and 0.5 seconds "OFF" with a three-second interval between each fault series. This sequence will repeat continuously until the diesel-burner switch is moved to the "OFF" position, the 12 Volt-DC power is disconnected from the diesel-burner's controller, or the Aqua-Hot's access cover is removed.

Should a diesel-burner malfunction occur, the Aqua-Hot Hydronic Heating System will cease operation and will activate the appropriate diesel burner blinking fault sequence. Count the number of flashes and contact the Aqua-Hot Heating Systems Technical Support Department at **1-800-685-4298**.

APPENDIX A: ANTIFREEZE TYPES

The following information addresses the necessary usage of a propylene glycol based "boiler" type antifreeze in the Aqua-Hot. Propylene glycol is a safer alternative to the more toxic ethylene glycol antifreeze; however, as mandated by IAPMO (International Association of Plumbing and Mechanical Officials), only those propylene glycol based "boiler" type antifreezes deemed "Generally Recognized as Safe" (GRAS) by the FDA should be utilized.

Because of the significant impact various types of antifreeze can have on a hydronic heating system, including the level of safety provided, it has been recognized that there is a need to provide an explanation regarding two additional prominent types of antifreeze/coolant available. The following information should be utilized as an educational means of ensuring that the proper type of propylene glycol based antifreeze is selected:

RV & Marine Antifreeze:

These types of propylene glycol based antifreeze products are formulated specifically for "winterizing" applications only. Although RV & Marine antifreeze is often "Generally Recognized as Safe" by the FDA, it should never be used in the Aqua-Hot's Hydronic Heating Sys-

tem. This type of antifreeze is not formulated to transfer heat, which is essential to the heating system's functionality and does not contain rust inhibitors. Please note, however, that RV & Marine antifreeze can be utilized to winterize the Aqua-Hot's Domestic Hot Water Heating System.

Automotive Antifreeze/Coolant:

These types of propylene glycol based antifreeze products are formulated specifically to protect automotive engines against corrosion, freezing temperatures, and overheating. They also have excellent heat transfer and thermal conductivity characteristics. Although these types of antifreeze products are considered less toxic and safer than ethylene glycol for people, pets, and the environment, they are not "Generally Recognized as Safe" (GRAS) rated by the FDA. Therefore, they must be marked with a "harmful if swallowed" warning. This additional warning is required because these types of antifreeze products contain high levels of chemical rust inhibitors. Due to their potentially hazardous properties, they should never be used in the Aqua-Hot's Hydronic Heating System.

APPENDIX B: ANTIFREEZE MIXTURE WATER QUALITY RECOMMENDATIONS

In order to ensure maximum performance and longevity of an Aqua-Hot heating system's boiler tank and associated components, it has been determined that there is a need to use distilled, de-ionized, or soft water in combination with concentrated propylene glycol for the Aqua-Hot's antifreeze and water heating solution. Please note that this is only necessary when mixing concentrated propylene glycol antifreeze with water; suppliers of pre-mixed antifreeze are responsible for the use of high-quality (distilled, de-ionized, or soft) water when preparing their antifreeze for sale.

Hard water possesses a high-level of calcium and magnesium ions, which deplete the propylene glycol antifreeze's corrosion inhibitors. This, in turn, causes the antifreeze and water heating solution to begin turning acidic, which can corrode the Aqua-Hot's Boiler tank and associated components prematurely. Therefore, concentrated propylene glycol should be diluted with distilled, de-ionized, or soft water which is 80 ppm or less in total hardness. The local water agency should have up-to-date water quality reports which should indicate if the local tap water is within this guideline.

APPENDIX C: ANTIFREEZE TERMS AND MIXTURE RATIO

The following information addresses the process of selecting a propylene glycol based antifreeze solution that provides adequate freeze, boiling, and rust/anti-corrosive protection. A 50/50 mixture ratio is recommended, which will result in a freeze point of approximately -28°F . and a boil point of approximately 222°F .

The following information should be utilized for the purpose of clarifying some terms commonly associated with antifreeze.

Freeze Point and Burst Point:

Antifreeze solution lowers the freezing point of any liquid, to which it has been added, by preventing the formation of ice crystals; however, as the ambient temperature continues to decline, the water in the solution will attempt to attain a solid state. The point in which the water begins to solidify is termed the “freeze point.” Although the water in the solution has begun to freeze, producing a “slushy” consistency, the antifreeze in the solution will continue to combat the normal expansion of the solution as it freezes. The point in which the solution can begin to expand, due to colder temperatures, is called the “Burst Point.” Once the solution reaches the burst point, the potential is present for ruptured pipes to exist. The burst point of the antifreeze and water heating solution is dependent upon the brand of propylene glycol antifreeze employed.

Boiling Point:

The Aqua-Hot utilizes the propylene glycol based (PPG) antifreeze and water heating solution as a transportation means for the heat produced from the internal processes. The PPG antifreeze solution absorbs the heat created until its boiling point is reached; it is at this point that the liquid turns to a gas and is expelled to prevent the heating system from overheating. Each time the boiling point is reached, a loss of efficiency occurs because the heat produced is expelled rather than utilized for the function of the heating system. Therefore, a higher boiling point is desired in order to combat the loss of efficiency, which allows the antifreeze to transport the heat created from the internal process throughout the motorhome where it can be utilized productively rather than dissipating due to its change from a liquid to a gas.

Rust and Anti-Corrosive Inhibitors:

Another major function of antifreeze solution is to provide protection to the internal metal components of the Aqua-Hot hydronic heating system from corrosion and rust. Antifreeze is able to perform this function by the addition of rust and anti-corrosive inhibitors, which are designed specifically to activate in a water solution.

Summary:

Antifreeze solution has three basic functions: freeze protection, boil-over protection, and anti-corrosion and rust protection.

PPG Antifreeze solution is also primarily responsible for heat transfer; however, propylene glycol itself does not possess acceptable heat transfer characteristics. Therefore, water is added to the mixture because it is an excellent heat conductor. PPG antifreeze solution, mixed with water, that is 35% to 50% propylene glycol is recommended to provide the best performance combination of the aforementioned functions. If excess propylene glycol exists within an antifreeze and water heating solution, the water's heat absorption properties are compromised, which could ultimately inhibit the Aqua-Hot from providing adequate domestic hot water and interior heating.

Additionally, if the antifreeze and water heating solution contains over 70 percent propylene glycol, the freezing point is actually raised, resulting in less freeze protection. Please reference the attached graphical representation regarding the percentage of antifreeze to water and how it directly affects the solution's freezing point.

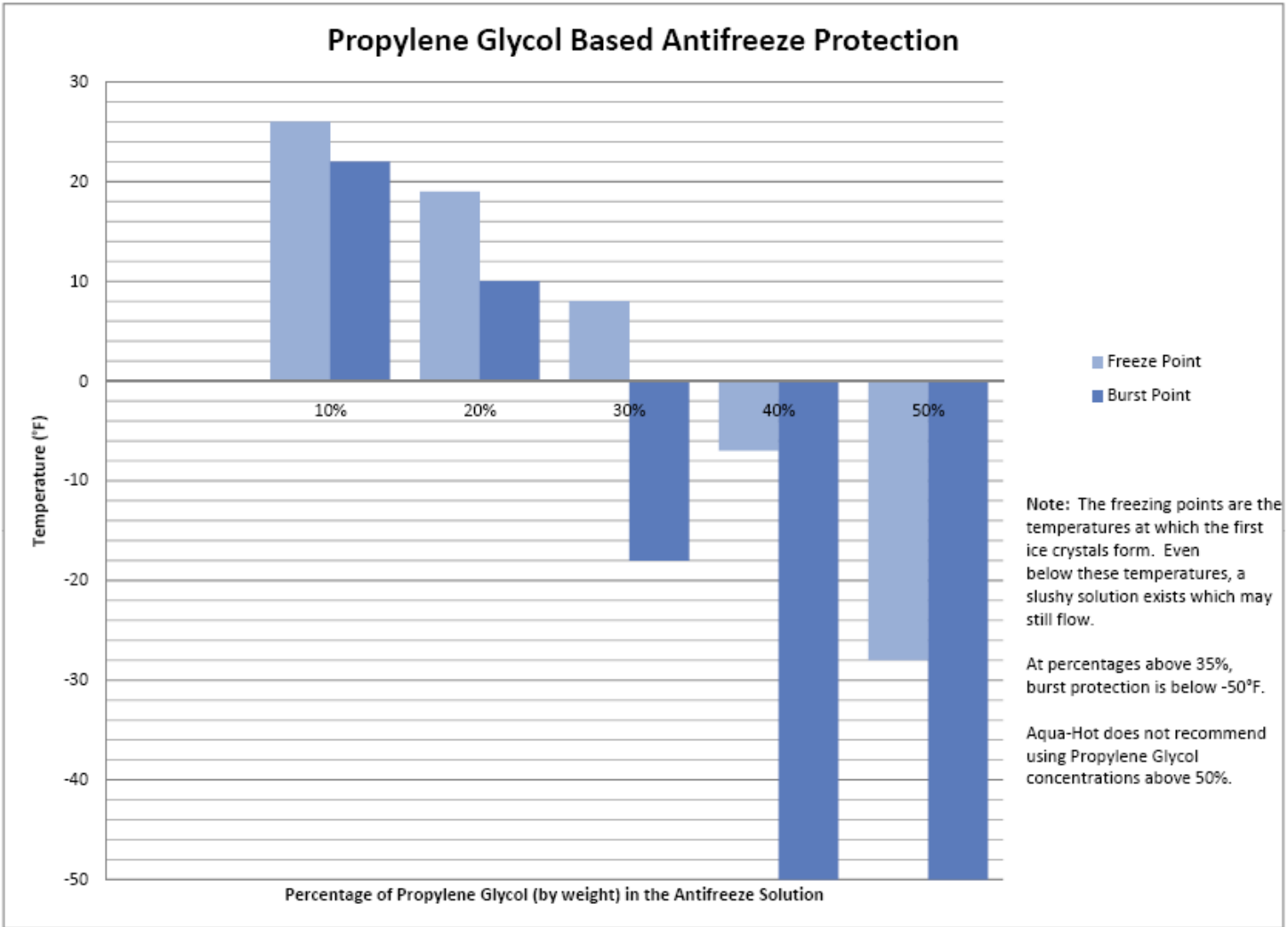

APPENDIX D: MEASURING PROPYLENE GLYCOL USING A REFRACTOMETER

Calibrate the Refractometer

Aqua-Hot Part Number MSX-907-162

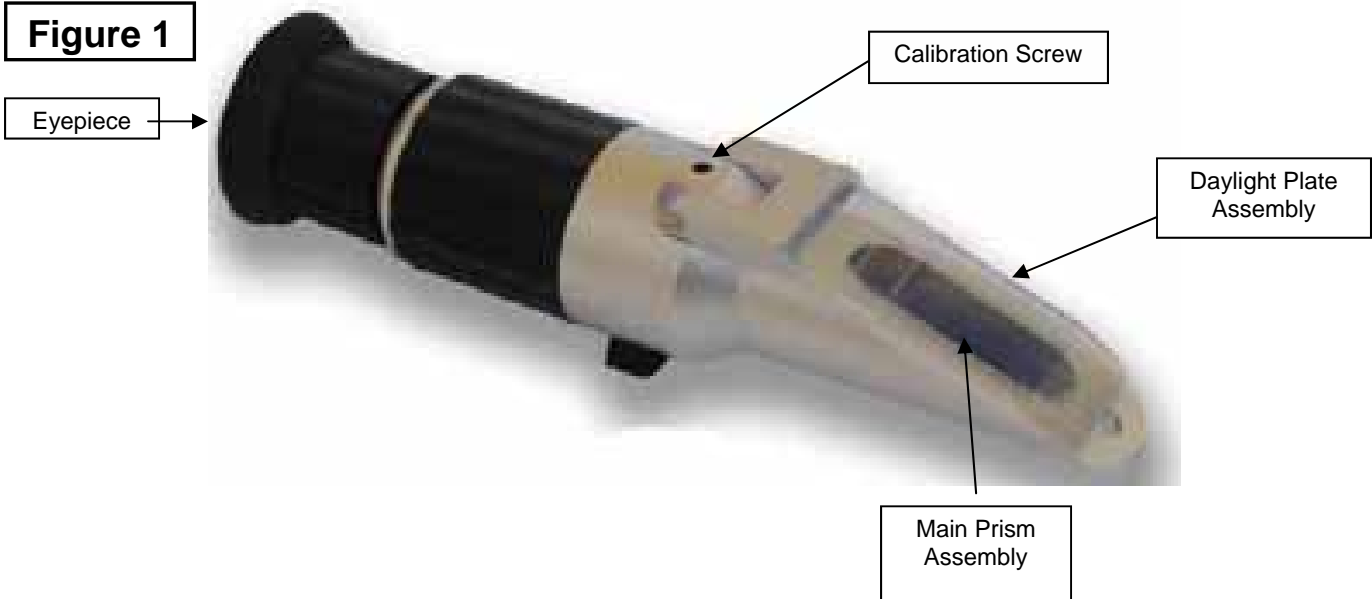

Calibration Procedure

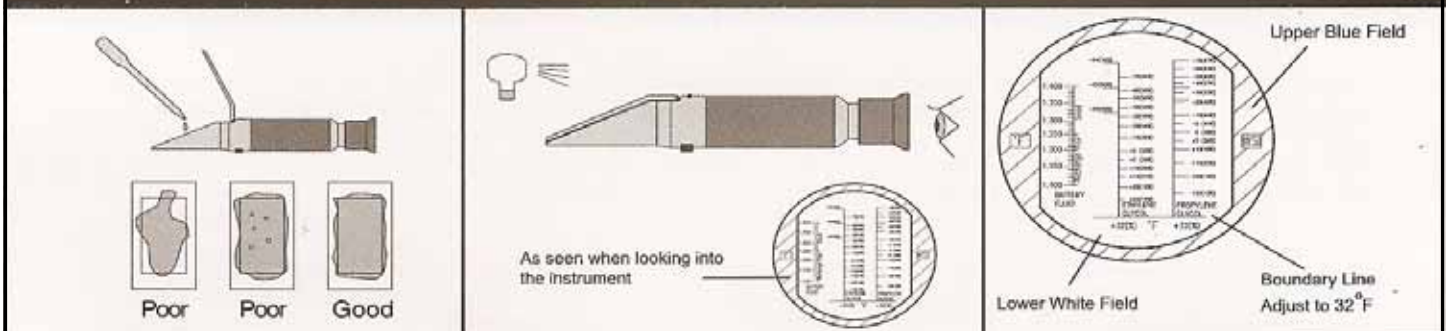

Using the Refractometer to Test Antifreeze Sample

⚠ WARNING! ⚠

Use extreme caution in gathering your antifreeze sample. When draining the Aqua-Hot heating system, extremely hot liquid may be in the Boiler Tank and could cause personal injury.

Basic Operation

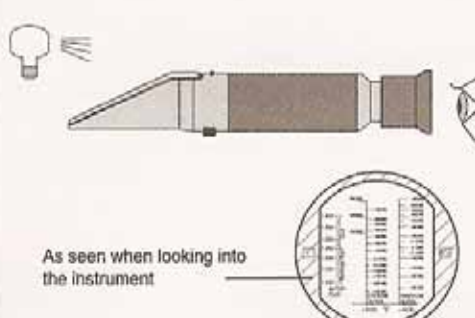
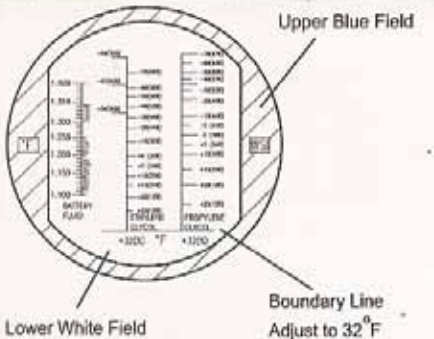
 <p>Poor Poor Good</p>	 <p>As seen when looking into the instrument</p>	 <p>Upper Blue Field</p> <p>Lower White Field</p> <p>Boundary Line Adjust to 32°F</p>
<p>1. Open daylight plate, and place 2-3 drops of the sample on the main prism. Close the daylight plate so the liquid sample spreads across the entire surface of the prism without air bubbles or dry spots. Allow the sample to rest on the prism for approximately 30 seconds before going to step #2. (This allows the sample to adjust to the ambient temperature of the refractometer).</p>	<p>2. Hold daylight plate in the direction of a light source and look into the eyepiece. You will see a circular field with graduations down the center (you may have to focus the eyepiece to clearly see the graduations). The upper portion of the field should be blue, while the lower portion should be white.</p>	<p>3. Take the reading where the boundary line of blue and white cross the graduated scale. The scale will provide a reading of the freezing point of antifreeze solution and the propylene glycol concentration. Clean the prism carefully using a damp soft cloth. Do NOT immerse in water.</p>

NOTE: Refractometers may have more than one scale. Make sure you are reading the scale marked "Propylene" for measuring the anti-freeze solution in the Aqua-Hot system.

This area provided for notes.

2-YEAR LIMITED WARRANTY
AQUA-HOT® HYDRONIC HEATING SYSTEM
AHE-375-LP

Aqua-Hot Heating Systems Inc. warrants the Aqua-Hot Heater to be free from defects in material and workmanship under normal use and service for a period of two years on both parts and labor commencing upon the original date of registration of the vehicle. Replacement parts are warranted for the remainder of the Heater's standard warranty coverage or for six months, whichever is greater.

The intent of this warranty is to protect the Heater's end-user from such defects, which would occur in the manufacturing of the product. Thus, problems due to improper specifications, improper installations, improper use, the use of accessory parts or parts not authorized by Aqua-Hot Heating Systems Inc., repair by unauthorized persons, and damage or abuse of the Heater are specifically excluded from warranty coverage.

For additional information or to obtain a warranty repair authorization, please contact the Aqua-Hot Heating Systems Warranty Administrator at 1-800-685-4298 (8:00 AM to 5:00 PM Mountain Standard Time) or visit www.aquahot.com.

 **Aqua-Hot**[®] HEATING SYSTEMS INC. 15549 East Highway 52 | Fort Lupton, CO 80621
800-685-4298 | Fax: 303-857-9000 | www.aquahot.com