



Imported by:
STEPHANIE MCNEIL CORPORATION

250 Augusta Avenue - Suite 204
Toronto, Ontario, M5T 2L7
Canada
(647) 879-7837

info@studiotitanamerica.com
studiotitanamerica.com

Made in: South Korea



CAUTION: Use leather work gloves and safety glasses when handling the box, when opening the box and when assembling the product.

HAZARD: Strapping is under tension and can jump when cut. Strapping and Buckles, Protective Edging, Plastic Walls, Plastic Caps and Product Components and parts should be handled with care. Work slowly, use extra caution to avoid any sharp edges.

Additional Tools may be Required: The essential tools are included. The following tools are recommended to be on site: Box Cutter, Scissors, Screw Driver, Pliers or Adjustable



!!!! WARNING !!!!
TO AVOID DANGER OF
SUFFOCATION, KEEP
PLASTIC BAGS
SUPPLIED WITH THIS
PRODUCT AWAY FROM
BABIES AND CHILDREN!

WARNING: Cancer
and Reproductive Harm -
www.P65Warnings.ca.gov



Transit Damage:

Each package is inspected prior to being shipped from the warehouse to insure that is in perfect condition. The column shipping boxes are constructed using extra thick cardboard. Some packaging includes engineered plastic walls, end caps and banding. The columns are packed using engineered plastic walls and in dense foam to protect and absorb energy from reasonable drops and impacts. The column packaging is designed and drop tested from approximately 5 feet [1.5 Meters] without sustaining any internal damage. The packaging is crush tested using a 660lb [300kg] weight placed along the long side of the box without sustaining any internal damage. If handled without care the boxes will show signs of transit damage. Wearing work Gloves, while following the Assembly Steps, carefully inspect the contents inside the boxes. Specifically the Vertical center column top cap pulley should be securely fastened to the top of the Vertical center column as shown on the [component identification] page. In the base, the transportation counterweight securing transportation screw should be secured to the counterweight. [See Diagram: E] If anything seems unusual, !!!STOP!!! Send images to: info@studiotitanamerica.com for a second opinion. If there are damaged OR Loose parts, do not assemble the stand, you may injure yourself. If the damage is noticeable such as cracks or loose or broken parts contact your dealer for exchange. If the damage is minor or cosmetic and does not compromise the safe assembly or operation of the stand send images of the parts that are affected to: info@studiotitanamerica.com. We will make arrangements to provide you with replacement parts to restore the stand to new condition.



Product Identification:



Product Nameplate / Label is located on the vertical column assembly.

The label information is indicated below:

STUDIO TITAN AMERICA

No.[Model Number] - [Manufacture Date]

Imported by / Importe par

STEPHANIE MCNEIL CORPORATION

250 Augusta Ave, Suite 204

Toronto, ON M5T 2L7 CANADA

Manufactured in / Fabrique en

SOUTH KOREA

 **WARNING:** Cancer
and Reproductive Harm -
www.P65Warnings.ca.gov

Label examples are indicated below:



Intended use:

This product is intended for use by professional and commercial photographers in a studio environment with a high ceiling. The wheels are designed to be used indoors on a floor that is smooth, hard, flat and unobstructed. The Studio Stands with internal counterweight are designed to be used at all times with a load (Camera or laptop shelf or both). **CAUTION:** This product is not recommended for use by hobbyists or in a household environment with a low ceiling or carpeted floors. Carpeting or pitted surfaces are not recommended because of the increased rolling resistance which can cause the stand to tip over. If the surface is not ideal, the stand must be moved with **CAUTION**, very slowly, using both hands one at the top and the other at the bottom to steady the stand in order to prevent the stand from tipping over. If the surface is not ideal, lower the load to waist level before moving the stand. We also recommend the use of a sandbag or weight attached at the base when conditions are not ideal to prevent tipping over. Ultimately it's the users responsibility to understand how the stand operates and to use the stand within its specification limits, as intended to insure their own safety and the safety of their equipment. It is also recommended to use a short tether cable to secure the camera to the stand in the event that the head, head plate, attachment stud or camera adapter plate comes loose or fails. Some assembly is required, we recommend using an assistant during the initial product assembly. Please read all documentation prior to assembly.

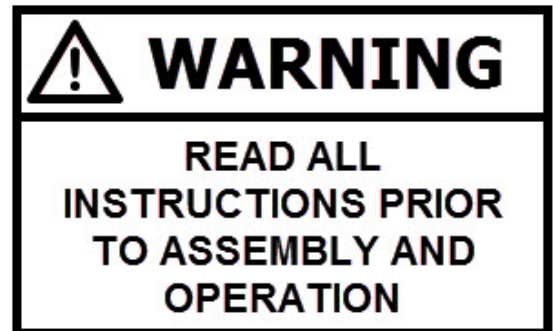

Component Identification: STA 01-360MK2

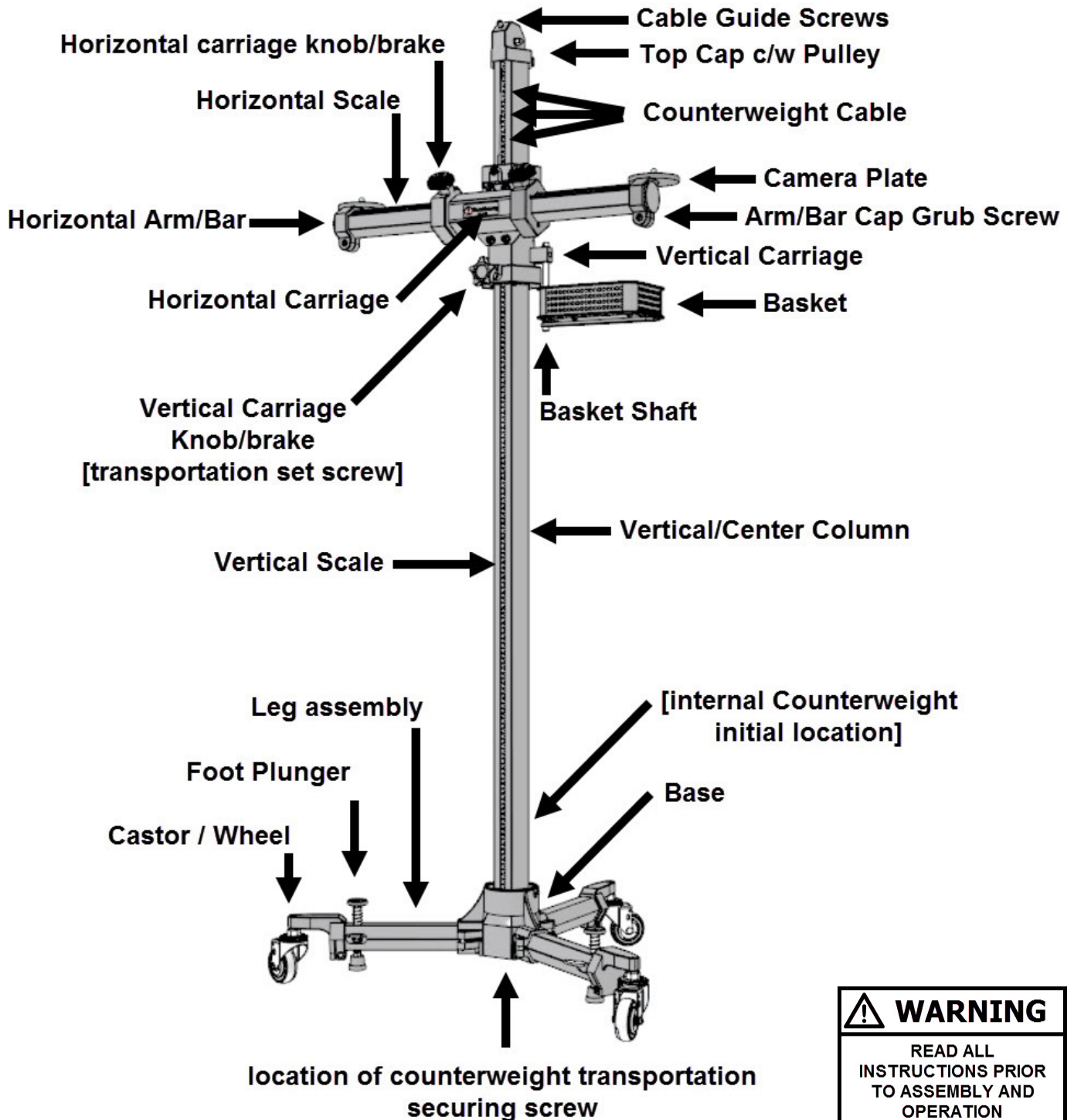

⚠ WARNING
READ ALL INSTRUCTIONS PRIOR TO ASSEMBLY AND OPERATION

Component Identification: STA 01-360MK2



Diagram: D

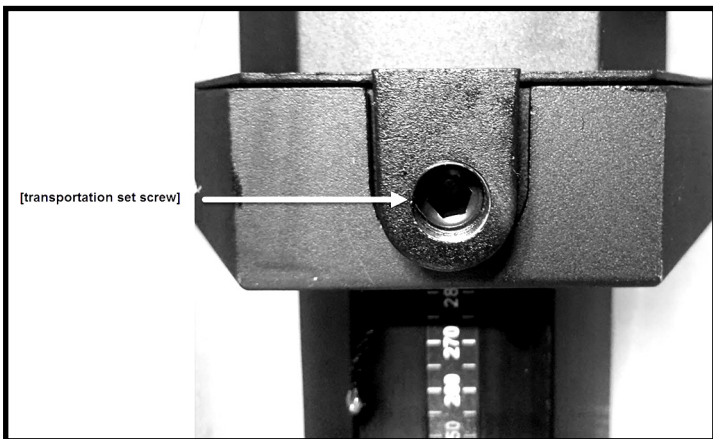
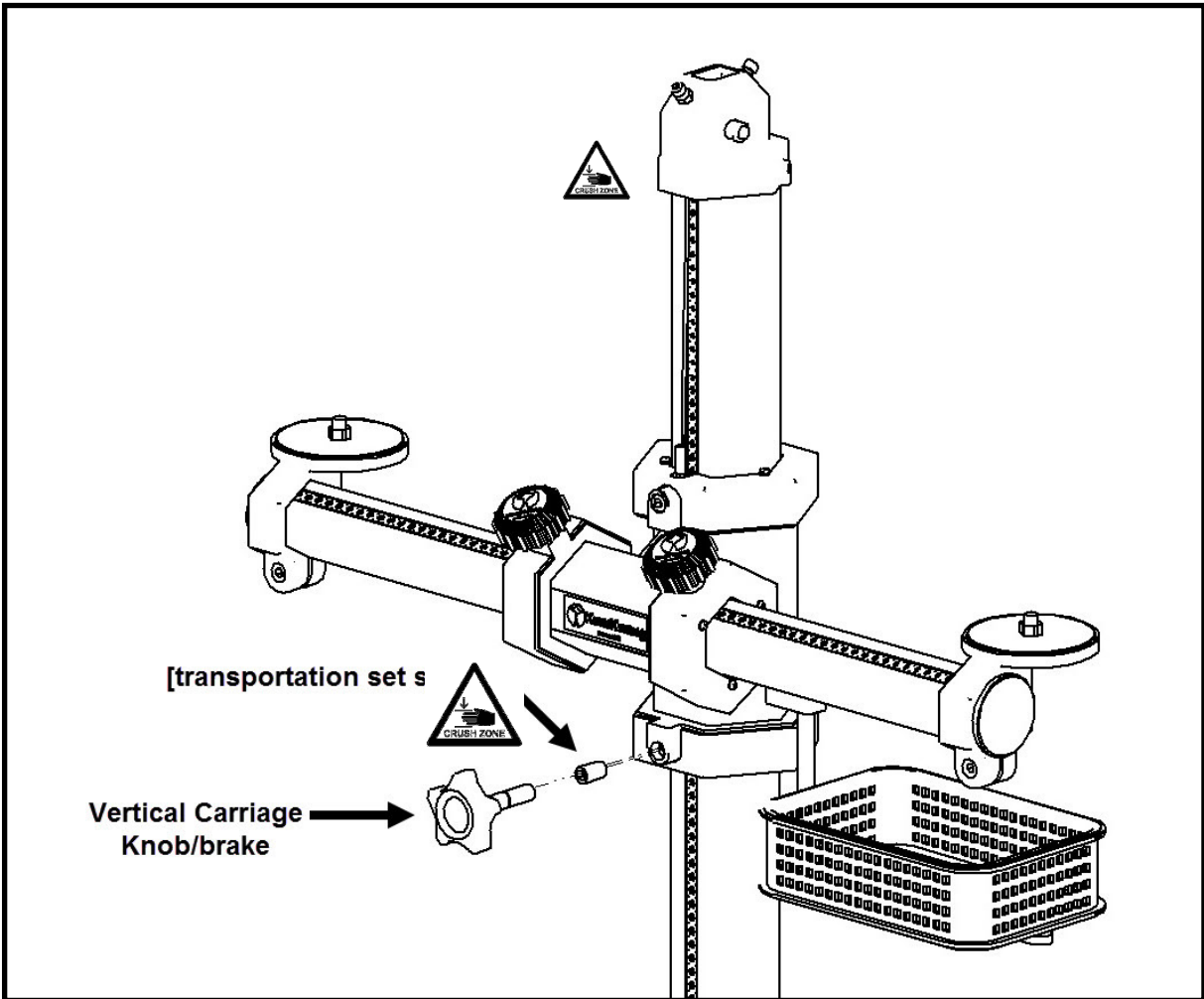

⚠ WARNING
READ ALL
INSTRUCTIONS PRIOR
TO ASSEMBLY AND
OPERATION

!CAUTION ! Cross Threading Components:



Cross-threading components during assembly is not covered under warranty.

Cross-threading is a term that describes damage that is caused when a misaligned screw or knob thread is forced into a threaded hole. When this occurs, threads are damaged and are no longer capable of proper operation. The remedy is replacement or repair of the damaged component/s.

AVOID cross-threading of mounting screws and knobs during assembly using this easy to follow procedure:

While standing in front of and looking into the threaded hole. Place the screw or knob thread against the threaded hole. Using one hand, hold the thread between your fingers. With the other hand hold the hex key like a pencil or place your index finger in the center of the knob. Align the screw or knob with the hole as indicated in the picture with the checkmark below. Slowly turn it counter-clockwise or left, several turns, until you hear a click or feel the start of the thread. Then proceed slowly, turning clockwise or right, gently using only finger force to tighten the screw or knob. If you feel increased resistance, the threads are not aligned, remove and start procedure from the beginning again.

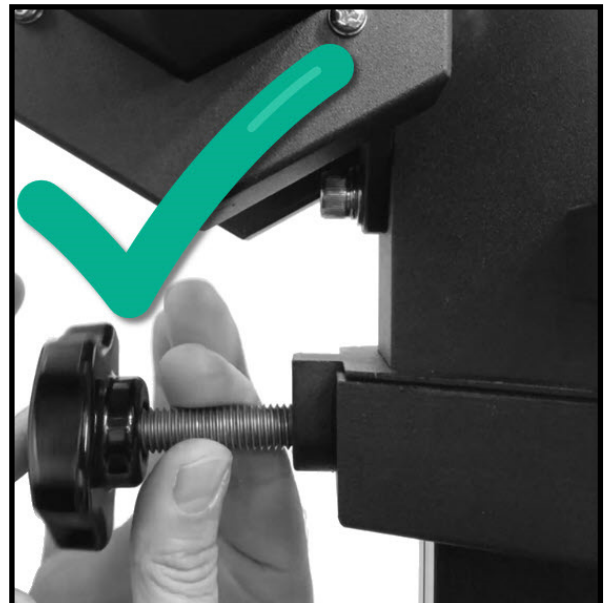
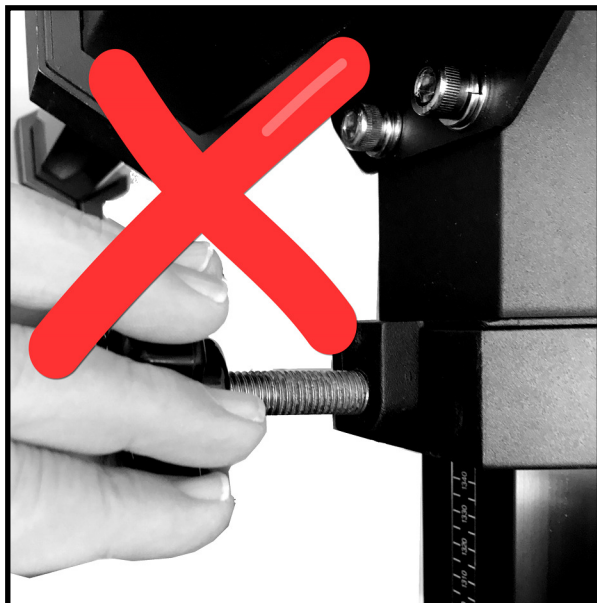

Assembly Steps:



1. Wearing Gloves and together with your Assistant...Wearing GlovesPlace the Column Box [long rectangular box] flat on floor. Place some packing materials on the floor. Do not remove and stand the Vertical/Center Column vertically. Remove the Vertical/Center Column and Lay the Vertical/Center Column flat on the floor. Under the Base, Visually inspect and Confirm that the Counterweight transportation securing screw is present. [See Diagram: D] Do NOT remove the Counterweight transportation securing screw until advised later. If the screw is present proceed with assembly. If NOT, then follow instructions below:

If the transportation securing screw is NOT present: the counter weight is loose and can move inside the column. Do not stand the column vertically upright. Stop the SET-UP and Contact us through the Studio Titan America website for further instructions. Please email: info@studiotitanamerica.com with the best phone number to reach you. We normally respond within 24hrs, during weekdays.

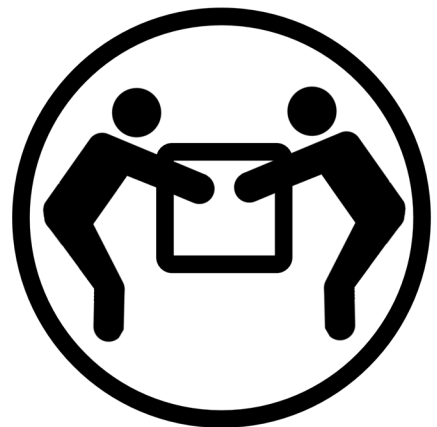

Assembly Steps:



2. Attach the three Leg Assemblies to the base. [See Diagram: A] The Hex Key tool is supplied and fasteners are supplied attached to the Base. Use the supplied Hex Key Loosen the fasteners, insert the legs and then re-tighten by hand. Note: two of the leg assemblies are supplied with foot plungers. To have direct access to the foot plungers you will want to install the foot plungers facing the operator or on the same side of the stand that the Horizontal and Vertical scales face. [An optional third leg assembly with foot plunger is available as a special order, please email info@studiotitanamerica.com for price and lead time.

3. Wearing Gloves, using the supplied Hex Key Tool, remove the counterweight transportation securing screw [See Diagram: E]

4. Locate and identify the counterweight cable from the component identification page. !!! CAUTION!!! AVOID CONTACT WITH THE COUNTERWEIGHT CABLE AT ALL TIMES. CAUTION MUST USED TO AVOID FINGER OR HAND INJURY DURING SET-UP AND NORMAL OPERATION. The counterweight cable may become frayed during transportation or normal use. When frayed, stop using the stand and immediately replace the cable. Cable strands that separate may become sharp.

WARNING

**READ ALL
INSTRUCTIONS PRIOR
TO ASSEMBLY AND
OPERATION**

Diagram: A

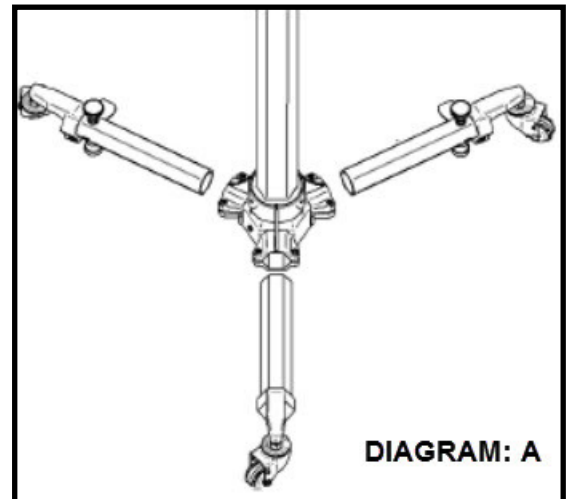

Assembly Steps:



WARNING

**READ ALL
INSTRUCTIONS PRIOR
TO ASSEMBLY AND
OPERATION**

5. Together with your Assistant...Wearing Gloves
.....Slowly raise and lift the Vertical/Center Column until it is standing freely on its feet/wheels.

6. Locate the M8 Hex Wrench. Refer to section "Cross Threading Components." Remove the four M8 x 20 bolts from the Vertical carriage. [See DIAGRAM: B] Locate the Horizontal Arm/Bar Carriage Assembly See [component identification] page. Together with your assistant. Have your assistant hold the Horizontal Arm/Bar Carriage Assembly in place while you fasten it with the four M8 x 20 bolts. Note the order [See DIAGRAM: B] [Bolt, Spring washer and then Flat washer]. Hand tightening with the Hex Wrench is recommended. If you have a torque wrench tighten the M8 bolts to 45Nm or 33 lb/ft not more.

7. Locate the M6 Hex Wrench. Locate the loose Vertical / Brake Knob. Locate the location of Vertical Carriage / Brake Knob See [Transportation Set Screw] [See DIAGRAM: D & B]. Refer to section "Cross Threading Components." With the M6 Hex Wrench Remove the transportation set screw and replace with Vertical Carriage / Brake Knob. Turn the Vertical Carriage /Brake Knob fully Clock Wise to secure the vertical carriage in the upper most or "parking position" [See DIAGRAM: D]

Diagram: B

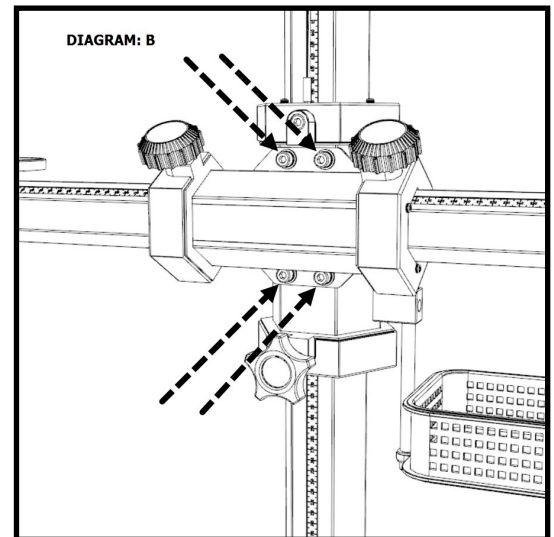
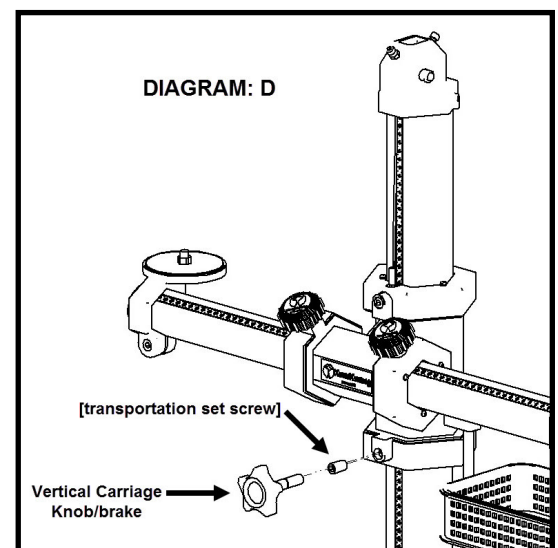

Diagram: D



Assembly Steps:



8. Locate two M8 Hex wrenches. Locate the Basket. Locate the Basket Shaft, See [component identification] page. With the first M8 hex key hold the M8 bolt at the top of the Basket shaft. With the second M8 hex key loosen the M8 bolt at the bottom of the Basket shaft. Attach the Basket to the Basket Shaft. Note the order of fastener connection: [Bolt, Flat washer, Basket Plate, Flat Washer]. [See: Component Identification page and DIAGRAM: C]

9. CAUTION: [Only with the Horizontal Arm/Bar in the upper most position "parking position".] Slowly release the Vertical Carriage Knob/brake by turning it Counter Clock Wise. This will release the vertical carriage allowing it to travel freely up and down the Vertical Center / Colum. Confirm that the Vertical Carriage is free to move in both directions while using both hands to hold the Horizontal Arm/Bar. Turn the Vertical Carriage Knob/brake fully Clock Wise to secure the vertical carriage.

10. Locate the Two Horizontal Carriage Knob/ Brakes, See [component identification] page. Turn the Horizontal Carriage Knob/Brake Counter Clockwise to release and confirm that the Horizontal Arm / Bar is free to move left and right.

STOP SET-UP— Read below— GO TO STEP 11 If anything seems unusual or if the vertical carriage is not moving freely up or down. Stop Set-up and send a few images of the stand to: info@studiotitanamerica.com for assistance.



WARNING

**READ ALL
INSTRUCTIONS PRIOR
TO ASSEMBLY AND
OPERATION**

Diagram: C

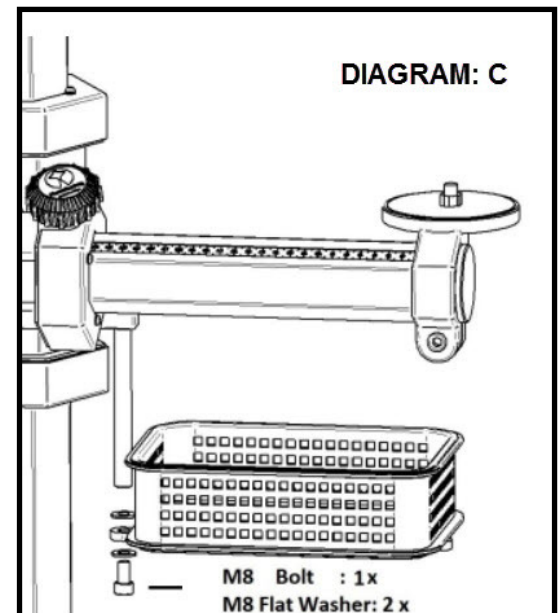

Use & Maintenance Steps:



11. HAZARD: Stop and take a moment to understand the effect of the counterweight. HAZARD: The counterweight forces the vertical column to travel towards the top of the Studio Stand. Without a load [Camera, laptop, etc.] on the horizontal Arm/Bar it can travel quickly towards the top of the stand. HAZARD: Never use the stand without a load [Camera, laptop, etc.]. Always securely "Park" the Vertical Carriage by Turning the Vertical Carriage Knob/brake fully Clock Wise before and after re-positioning or before the stand is unloaded [removing Camera, laptop, etc.].

12. HAZARD: Work in such a way so your always standing behind or in front of the stand so that you always stand clear of the Horizontal Arm/Bar and accessories. Take extra notice of your body position when you are releasing the Vertical Carriage knob. With your free hand apply a downward force to the Horizontal Arm/Bar Simultaneously as you release the Vertical Carriage knob.

13. Storage: Store with Vertical Carriage either in the upper most "Parking Position" with the load removed or store the Studio Stand with a weight or sandbag on the Horizontal Arm/Bar to counteract the effect of the counterweight, in the event that non-trained personal attempt to use the Studio Stand. Train all Studio personal prior to operating the Studio Stand.

14. Re-tighten all fasteners AGAIN. Re-tighten fasteners after the first shoot. Tighten yearly.



Theory of Operation:



A studio stand is used by professional and commercial photographers to capture images accurately with repeatability. It provides a rigid and stable platform essential for High Resolution Sensors used in DSLR, Medium Format and Large Format cameras and imaging systems. A studio stand reduces vibrations that are present when shooting hand held. Reduced vibration increases image sharpness. It enables the photographer to focus on subject matter and image composition instead of hand holding the camera. It provides creative shooting options using heights and angles that are unachievable when hand holding a camera. It provides the foundation stone that enables the photographer to develop their own technical workflow. As the workflow evolves to include advanced imaging practices, the results can be seen as sharper images.

With an adjustable camera head the user can accurately set up the camera to maintain camera to subject flatness of field in both the vertical and horizontal planes of travel. The flatness of field is maintained as the user moves the stand both vertically and horizontally eliminating perspective distortion. Shooting tethered with the optional digital imaging shelf, reduces floor cabling and allows the photographer to immediately confirm both focus and lighting.

A Studio Stand reduces user fatigue. The internal counter balance offsets the weight of the camera and notebook. Allowing the user to easily move the camera and notebook up and down and left and right using only one hand. This promotes good body ergonomics which can prevent tennis elbow.

Tip Over Hazard:

Caution must be used when moving the stand to prevent tip over. Move the stand slowly and avoid uneven surfaces as well as low and high level objects. Additional caution must be used when the Horizontal arm with load (Camera or Laptop Shelf) is used in the upper area above the midpoint of the stand.



Counterweight Hazard:

The Horizontal Arm/Bar is connected to a counterweight located inside the Vertical Center/Column. Caution must be used at all times when using the Horizontal Arm/Bar. The Vertical Carriage Knob/Brake must always be tightened to lock the Horizontal Arm/Bar in place. Without a load on the Horizontal Arm/Bar it can accelerate upwards quickly. When releasing the Vertical Carriage Knob/Brake stand clear of the arms path of movement, firmly hold the Horizontal Arm/Bar applying pressure downwards. Stand back to avoid contact with the Horizontal Arm/Bar when unloaded. Do not remove the load when the Vertical Carriage Knob/Brake knob is released or turned CCW. Unless repositioning the Vertical Center/Column intentionally the Vertical Carriage Knob/Brake must be fully engaged (turned fully clockwise). Store with Vertical Carriage either in the upper most "Parking Position" with the load removed or store the Studio Stand with a weight or sandbag on the Horizontal Arm/Bar.



Assembly Diagrams:

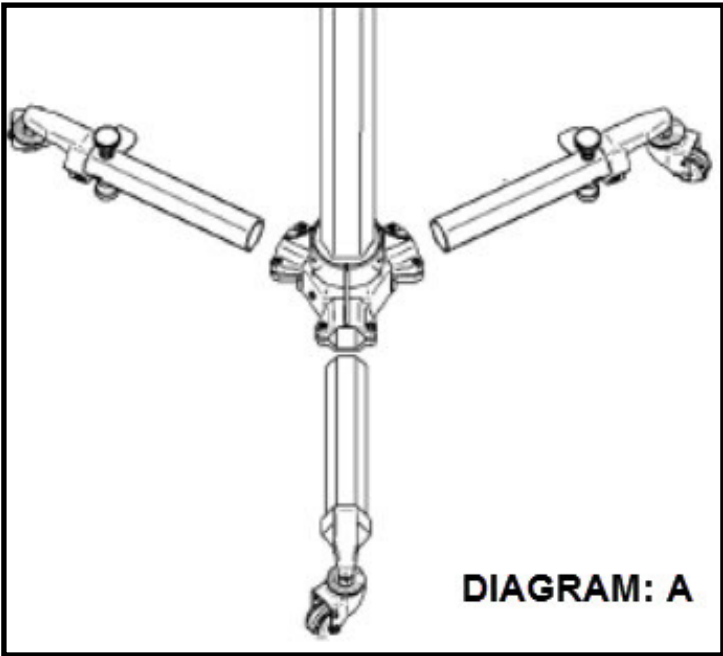

Diagram: A

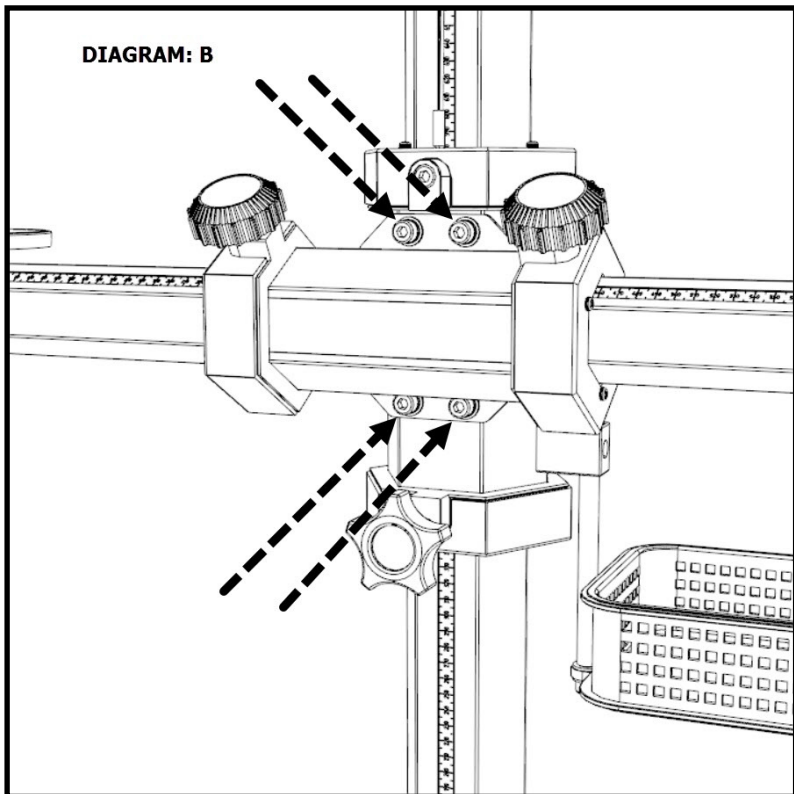
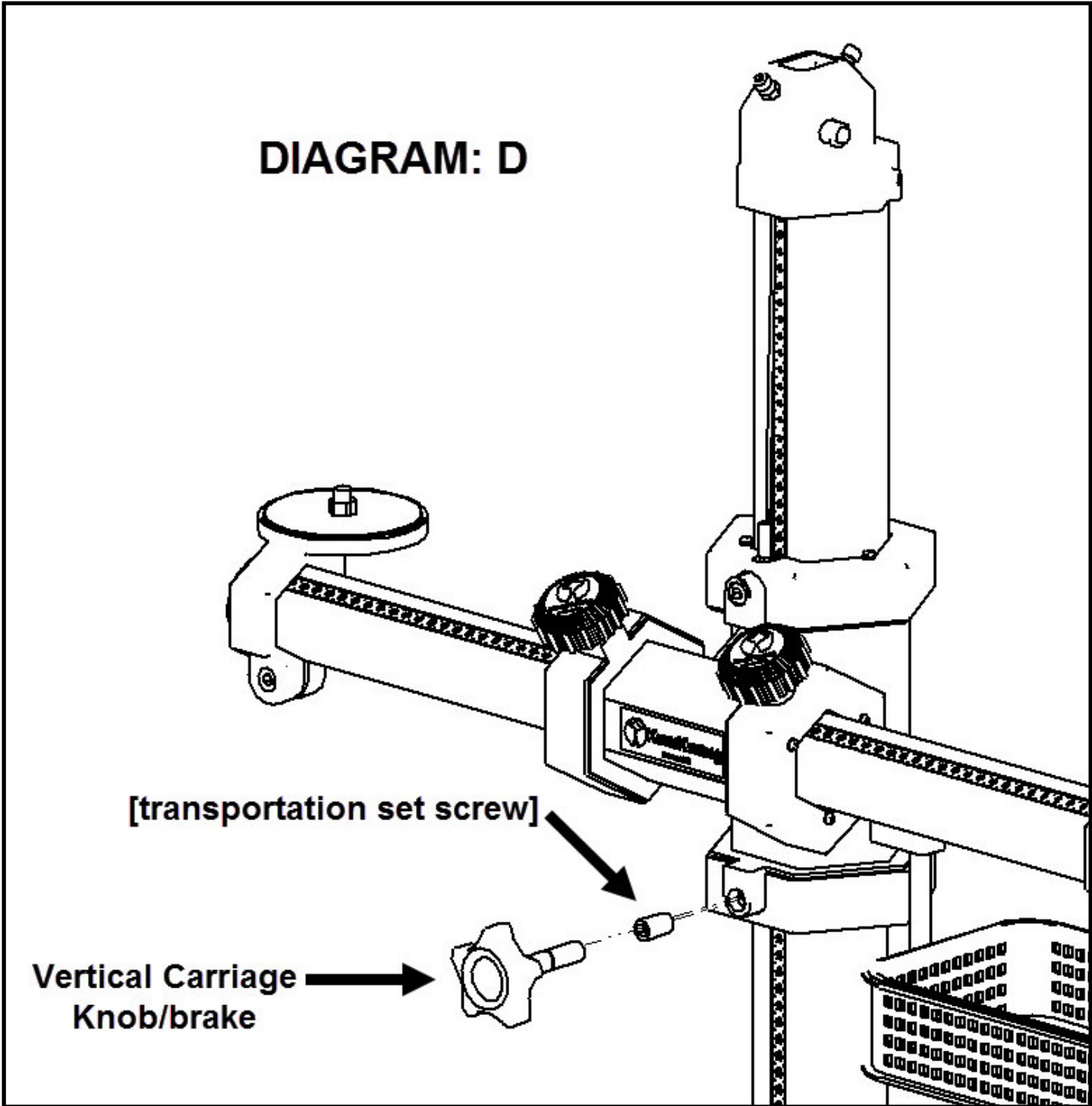

Diagram: B

Assembly Diagrams:

Diagram: D



Assembly Diagrams:



!!! CAUTION !!!

TO PREVENT THE COUNTERWEIGHT FROM MOVING DURING SET-UP. PLACE THE CAMERA STAND LYING DOWN OR HORIZONTALLY ALONG THE FLOOR WHEN REMOVING THE COUNTERWEIGHT TRANSPORTATION SECURING SCREW.

THE IMAGE BELOW SHOWS THE BOTTOM VIEW OF THE CAMERA STAND LOOKING INTO THE BOTTOM OF THE VERTICAL COLUMN. THE ARROW POINTS TO THE COUNTERWEIGHT TRANSPORTATION SECURING SCREW.

Diagram: E

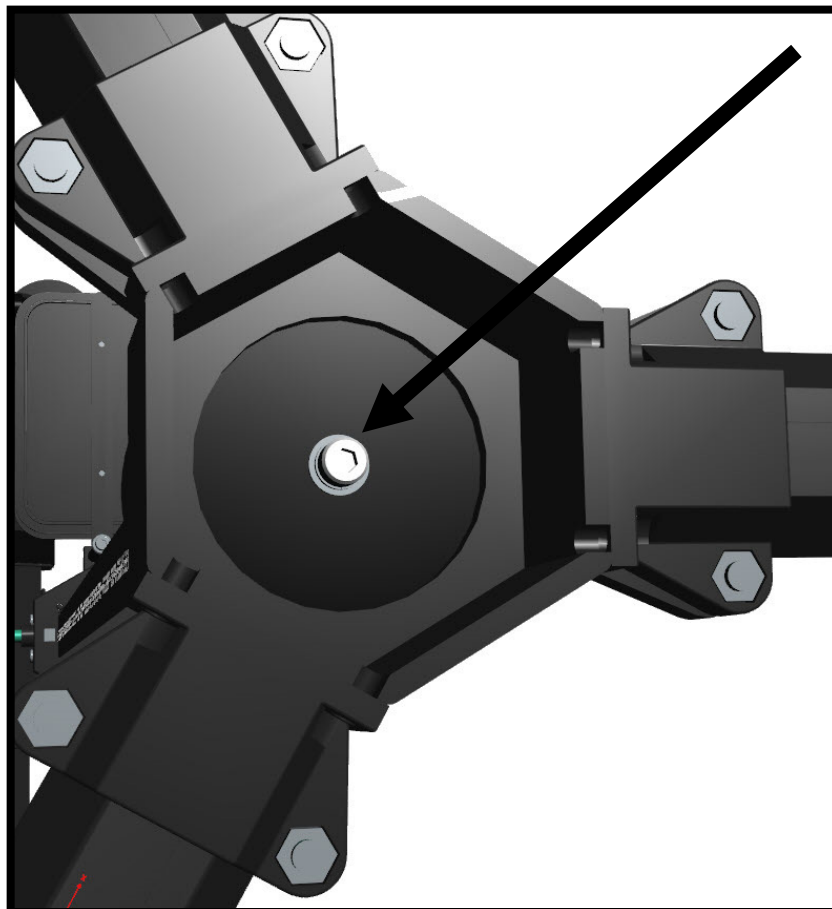

STA 01-360MK2 Specification



- **Total Height** : 192cm / 75.59 in
- **Working Height Maximum** : 180cm / 70.86 in (measured from Camera Plate to floor)
- **Working Height Minimum** : 50cm / 19.7 in (measured from Camera Plate to floor)
- **Working Width Horizontal - Fully Extended to Left** : 55cm / 21.6 in (center of Column to center of Camera plate)
- **Working Width Horizontal - Fully Extended to Right** : 55cm / 21.6 in (center of Column to center of Camera plate)
- **Overall Working Width Horizontal - Fully Extended from Left to Fully Extended Right** : 110cm / 43.2 in (center of Camera plate to center of Camera plate)
- **Width** : 85cm / 33.46 in
- **Weight** : 30kg / 66lbs
- **Suggested Wheels** : 01-360-20-024
- **Base Diameter** : 90cm / 35.4 in
- **Recommended General load capacity** : 7kg (15.4lbs)
- **Camera Plate Hardware**: 3/8th inch - 16 thread
- **Includes two Camera Head Mount Plates and Basket as shown**

Accessories for the STA 01-360MK2 Professional Studio Stand:

- Digital Imaging Accessory Shelf - Large STA-01-395 for notebook
- Digital Imaging Accessory Shelf - Small STA-01-397 for notebook
- STA-01-390 3-way head
- Travel Stop / Clamp-on STA 01-350MK2-TS
- Horizontal Arm Bar with scale and end caps 1115mm Length STA01-350HB-1115
- Lowering Plate STA-01-398
- Head Mount Plate STA-01-360HMP

Material composition: The Vertical and Horizontal columns are made of aluminum. Counter weight is S20C steel. The nuts and bolts are made of steel. The casters are polyurethane. This product does not contain lead.

STUDIO TITAN RESERVES THE RIGHT TO MAKE PRODUCT CHANGES AND PRODUCT ENHANCEMENTS. PRODUCTS SUPPLIED MAY NOT BE DELIVERED EXACTLY AS ADVERTISED OR SHOWN ON THE WEBSITE OR IN THE MANUAL.

- The column box blue outer plastic material is Polypropylene, abbreviated as PP, is a recyclable thermoplastic polymer widely used in many different products. PP is rugged. PP's resin identification code is 5, and it is recyclable.

- Plastic bags are made of LDPE (Low-Density Polyethylene) – Recyclable plastic (check Local Authority) LDPE can be recycled. However, check with your Local Authority to ensure it is recycled in your area. This is described as a hard flexible plastic.

- The Corrugated cardboard box can be recycled at depots, in municipal curbside collection programs and through private recyclers.

 **WARNING:** Cancer and Reproductive Harm - www.P65Warnings.ca.gov