



Imported by:  
**STEPHANIE MCNEIL CORPORATION**

250 Augusta Avenue - Suite 204  
Toronto, Ontario, M5T 2L7  
Canada  
(647) 879-7837

info@studiotitanamerica.com  
**studiotitanamerica.com**

Made in: South Korea



**CAUTION:** Use leather work gloves and safety glasses when handling the box, when opening the box and when assembling the product.

**HAZARD:** Strapping is under tension and can jump when cut. Strapping and Buckles, Protective Edging, Plastic Walls, Plastic Caps and Product Components and parts should be handled with care. Work slowly, use extra caution to avoid any sharp edges.

**Additional Tools may be Required:** The essential tools are included. The following tools are recommended to be on site: Box Cutter, Scissors, Screw Driver, Pliers or Adjustable wrench, Metric Hex / Allen Key set





**Transit Damage:**

Each package is inspected prior to being shipped from the warehouse to insure that is in perfect condition. The column shipping boxes are constructed using extra thick cardboard. Some packaging includes engineered plastic walls, end caps and banding. The columns are packed using engineered plastic walls and in dense foam to protect and absorb energy from reasonable drops and impacts. The column packaging is designed and drop tested from approximately 5 feet [1.5 Meters] without sustaining any internal damage. The packaging is crush tested using a 660lb [300kg] weight placed along the long side of the box without sustaining any internal damage. If handled without care the boxes will show signs of transit damage. Wearing work Gloves, while following the Assembly Steps, carefully inspect the contents inside the boxes. Specifically the Vertical center column top cap pulley should be securely fastened to the top of the Vertical center column as shown on the [component identification] page. In the base, the transportation counterweight securing strap should be secured to the counterweight. [See Diagram: E] If anything seems unusual, !!!STOP!!! Send images to: info@studiotitanamerica.com for a second opinion. If there are damaged OR Loose parts, do not assemble the stand, you may injure yourself. If the damage is noticeable such as cracks or loose or broken parts contact your dealer for exchange. If the damage is minor or cosmetic and does not compromise the safe assembly or operation of the stand send images of the parts that are affected to: info@studiotitanamerica.com. We will make arrangements to provide you with replacement parts to restore the stand to new condition.



## Product Identification:



**Product Nameplate / Label is located on the vertical column assembly.**

**The label information is indicated below:**

### **STUDIO TITAN AMERICA**

No.[Model Number] - [Manufacture Date]

Imported by / Importe par

STEPHANIE MCNEIL CORPORATION

250 Augusta Ave, Suite 204

Toronto, ON M5T 2L7 CANADA

Manufactured in / Fabrique en

SOUTH KOREA

**Label examples are indicated below:**





### Intended use:

This product is intended for use by professional and commercial photographers in a studio environment with a high ceiling. The wheels are designed to be used indoors on a floor that is smooth, hard, flat and unobstructed. The Studio Stands with internal counterweight are designed to be used at all times with a load (Camera or laptop shelf or both). **CAUTION:** This product is not recommended for use by hobbyists or in a household environment with a low ceiling or carpeted floors. Carpeting or pitted surfaces are not recommended because of the increased rolling resistance which can cause the stand to tip over. If the surface is not ideal, the stand must be moved with **CAUTION**, very slowly, using both hands one at the top and the other at the bottom to steady the stand in order to prevent the stand from tipping over. If the surface is not ideal, lower the load to waist level before moving the stand. We also recommend the use of a sandbag or weight attached at the base when conditions are not ideal to prevent tipping over. Ultimately it's the users responsibility to understand how the stand operates and to use the stand within its specification limits, as intended to insure their own safety and the safety of their equipment. It is also recommended to use a short tether cable to secure the camera to the stand in the event that the head, head plate, attachment stud or camera adapter plate comes loose or fails. Some assembly is required, we recommend using an assistant during the initial product assembly. Please read all documentation prior to assembly.



# Component Identification: STA 01-350MK2

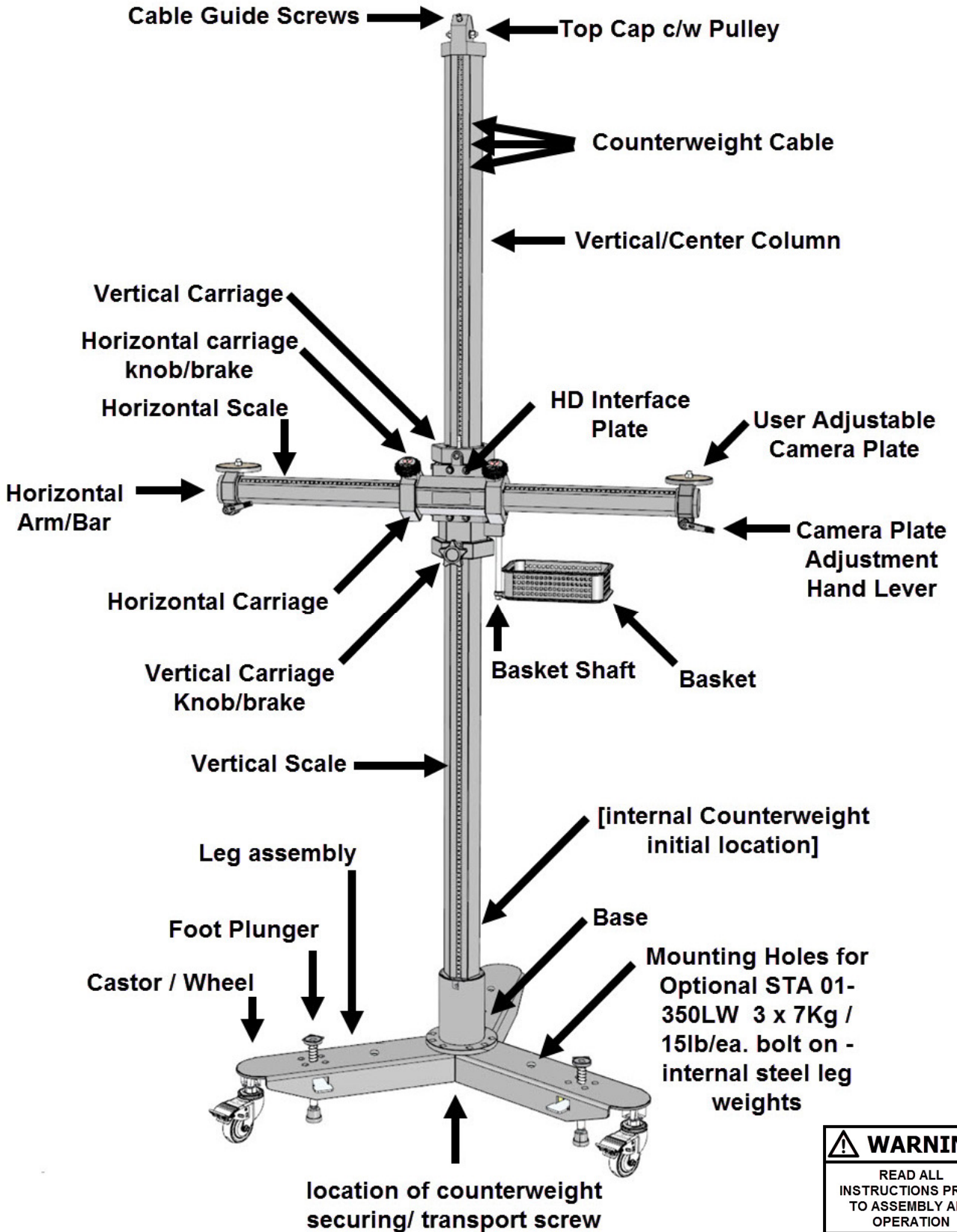

**Component Identification: STA 01-350MK2**



**Diagram: D**

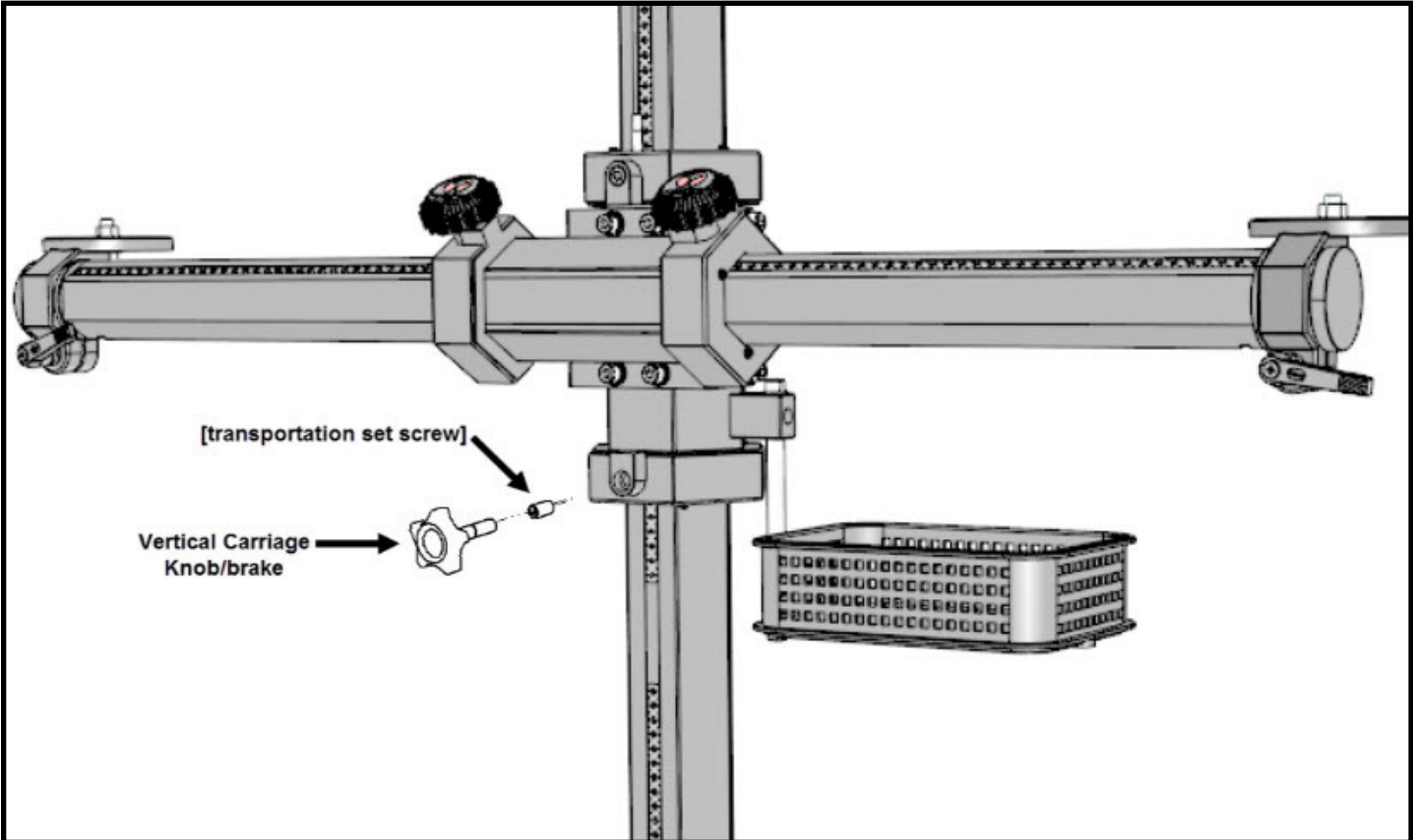
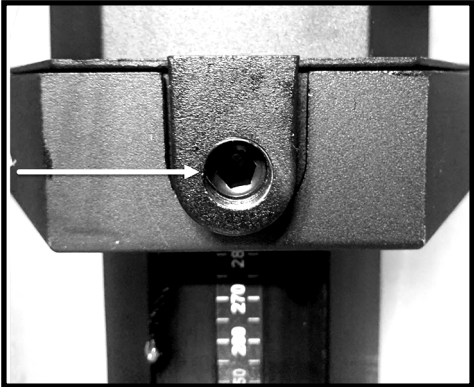
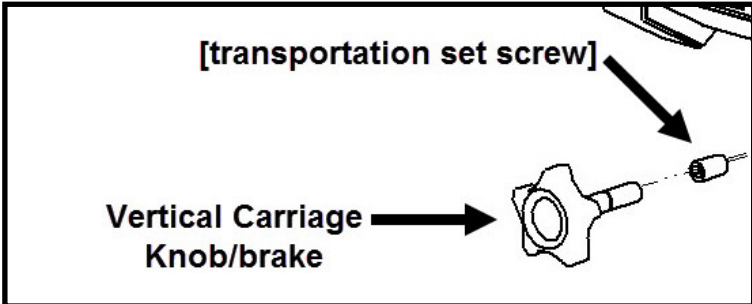

**⚠ WARNING**  
READ ALL  
INSTRUCTIONS PRIOR  
TO ASSEMBLY AND  
OPERATION

**!CAUTION ! Cross Threading Components:**

**Cross-threading components during assembly is not covered under warranty.**

**Cross-threading is a term that describes damage that is caused when a misaligned screw or knob thread is forced into a threaded hole. When this occurs, threads are damaged and are no longer capable of proper operation. The remedy is replacement or repair of the damaged component/s.**

**AVOID cross-threading of mounting screws and knobs during assembly using this easy to follow procedure:**

**While standing in front of and looking into the threaded hole. Place the screw or knob thread against the threaded hole. Using one hand, hold the thread between your fingers. With the other hand hold the hex key like a pencil or place your index finger in the center of the knob. Align the screw or knob with the hole as indicated in the picture with the checkmark below. Slowly turn it counter-clockwise or left, several turns, until you hear a click or feel the start of the thread. Then proceed slowly, turning clockwise or right, gently using only finger force to tighten the screw or knob. If you feel increased resistance, the threads are not aligned, remove and start procedure from the beginning again.**

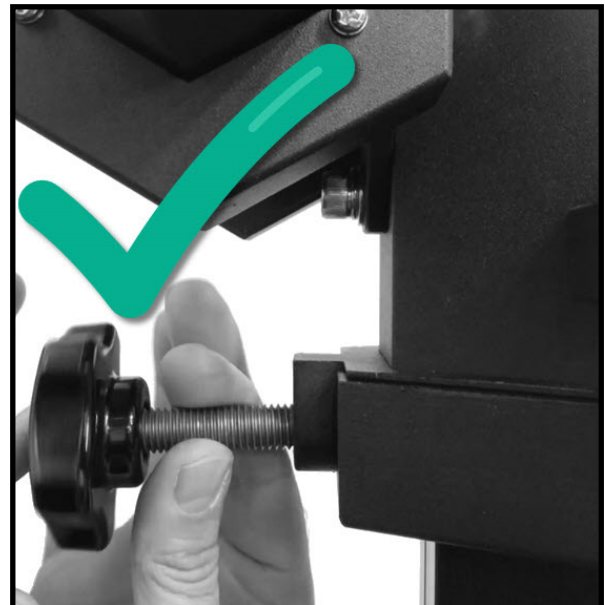
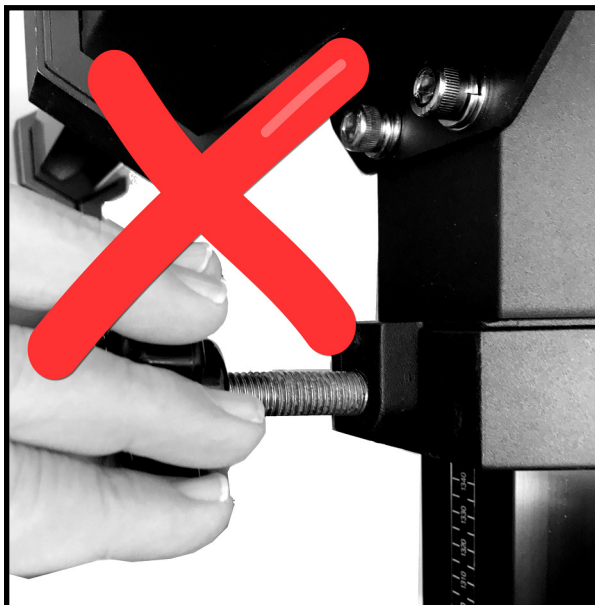

**Component Identification: STA 01-350MK2**



**Securing / Transport  
Screw**

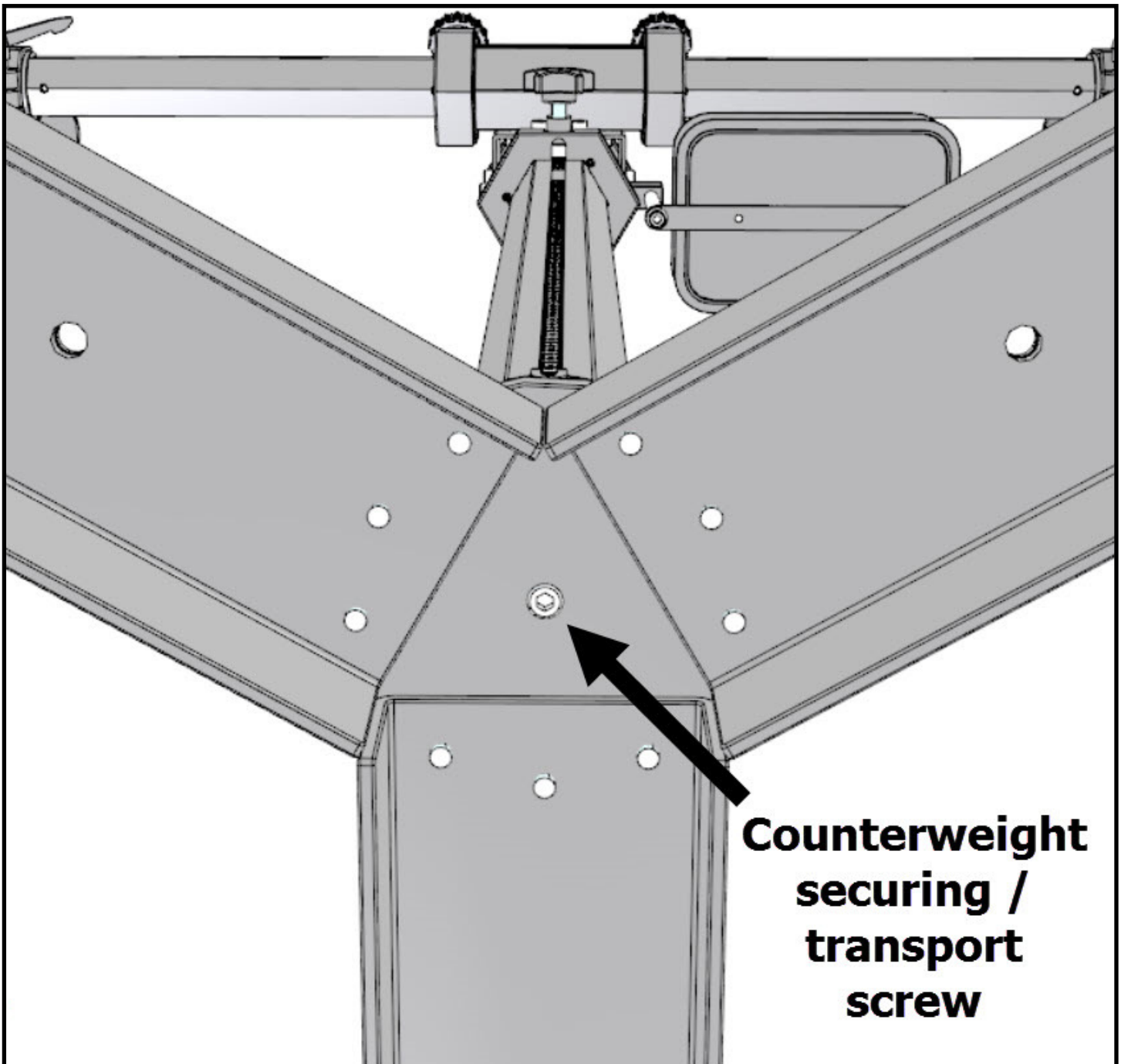

**Counterweight  
securing /  
transport  
screw**



**Component Identification: STA 01-350MK2**



**HD Interface Plate**

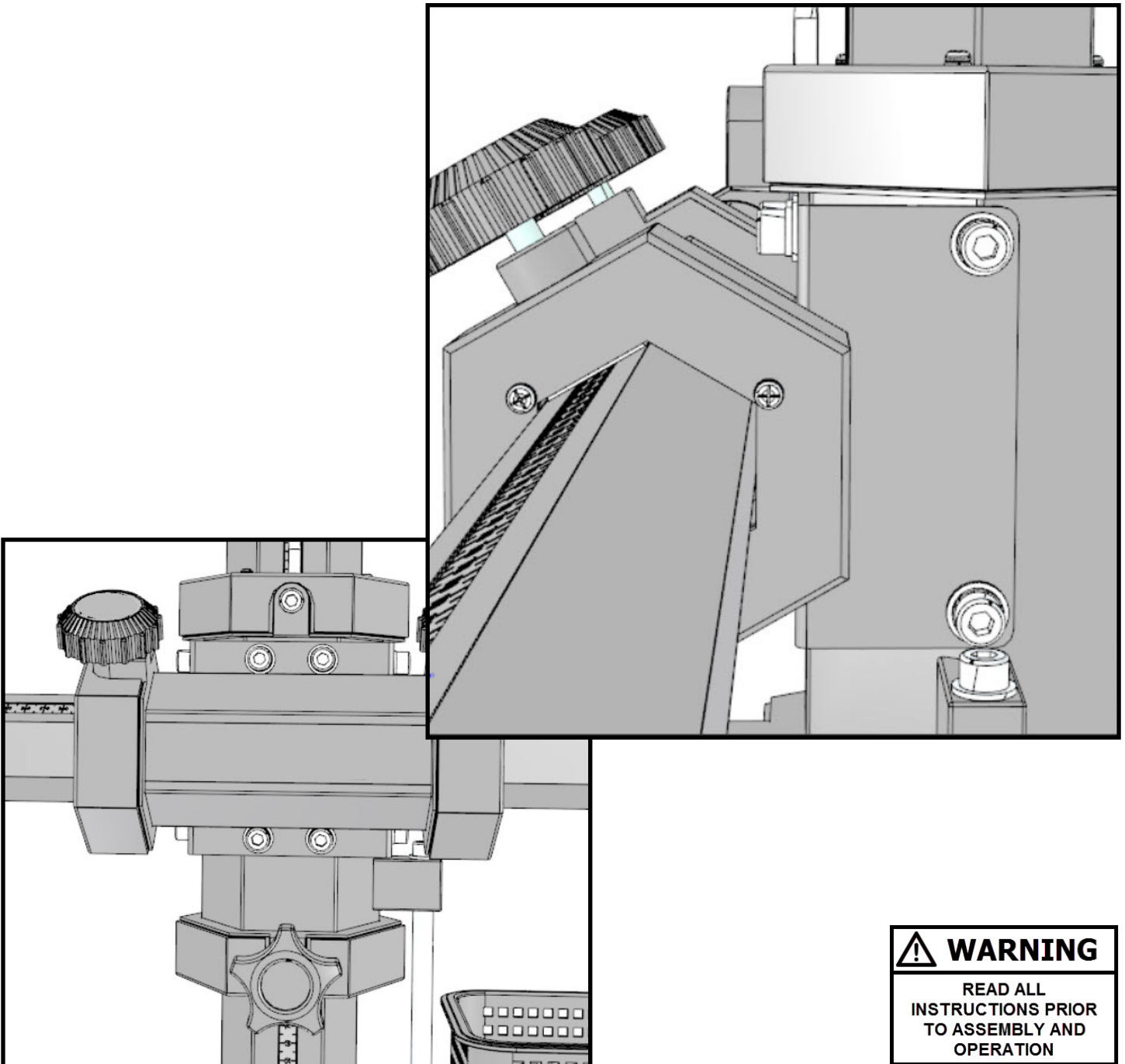

**⚠ WARNING**  
READ ALL  
INSTRUCTIONS PRIOR  
TO ASSEMBLY AND  
OPERATION

**Component Identification: STA 01-350MK2**



**Hand Lever adjustable, 360 degree range of movement, camera head mount plates**

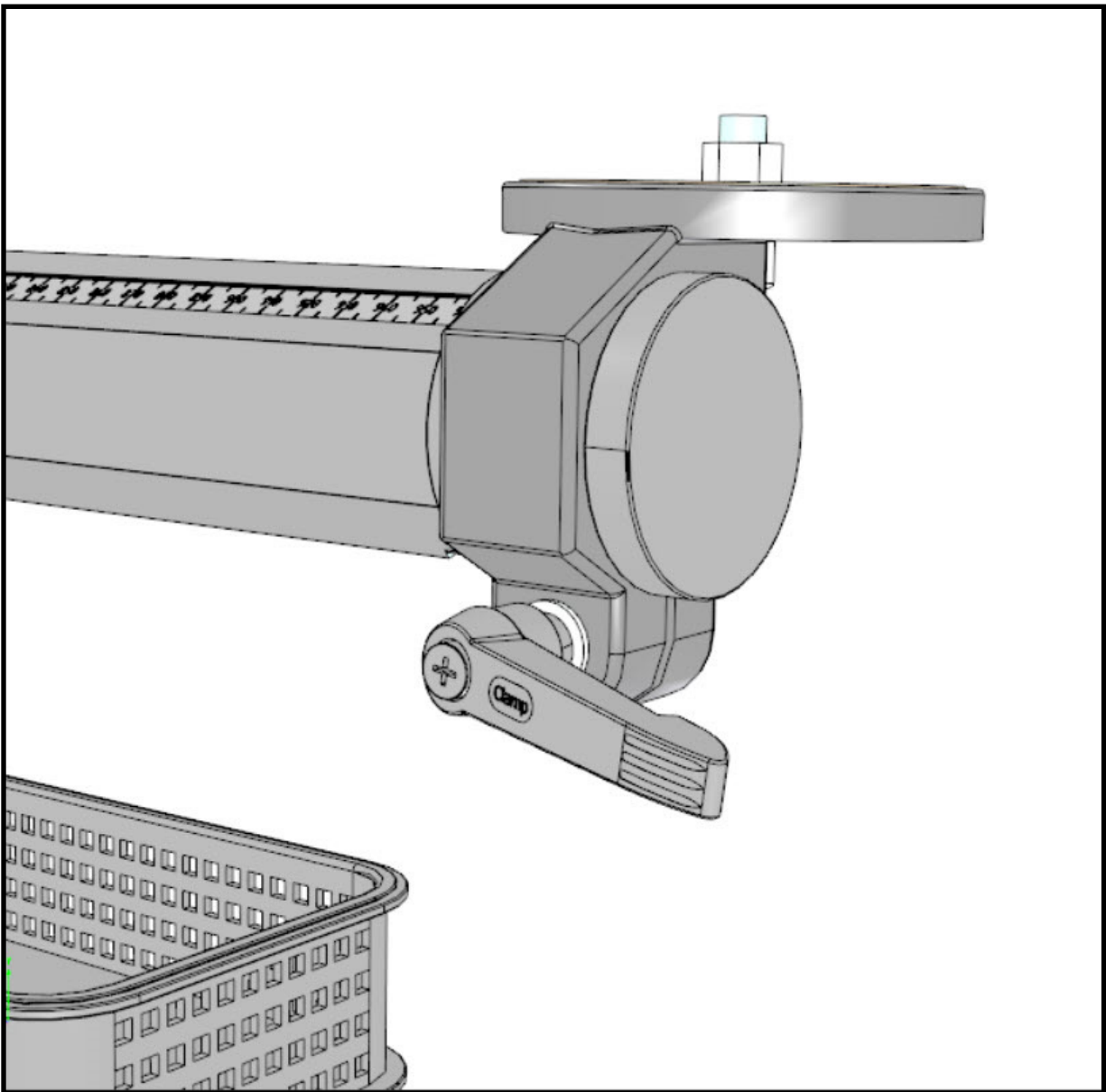

**⚠ WARNING**  
READ ALL  
INSTRUCTIONS PRIOR  
TO ASSEMBLY AND  
OPERATION

## Assembly Steps:



1. Wearing gloves and together with your Assistant.....Place the Column Box [long rectangular box] flat on floor. Place some packing materials on the floor. Do not stand the Vertical/Center Column vertically. Remove and Lay the Vertical/Center Column flat on the floor. Under the Base, Visually inspect and Confirm that the Counterweight transport securing SCREW is present which secures the counterweight during transportation. Do NOT remove the Counterweight transport securing SCREW until advised later. Confirm the bolt is present and proceed to step 2 with assembly. If NOT, then:

If Counterweight transport securing SCREW is NOT present, the counter weight is loose and can move inside the column. Do not stand the column vertically. Stop the SET-UP and Contact us for further instructions. Please email:

[info@studiotitanamerica.com](mailto:info@studiotitanamerica.com) with the best phone number to reach you. We normally respond within 24hrs, during weekdays.



## Assembly Steps:



### **WARNING**

READ ALL  
INSTRUCTIONS PRIOR  
TO ASSEMBLY AND  
OPERATION

2. Attach the three Leg Assemblies to the base. [See Diagram: A] Three fasteners are supplied attached to each Leg Assembly. Use the supplied Hex Key tool to tighten the nine fasteners by hand. Attach the vibration reduction brackets to the legs using the Hex key tool and four fasteners lock washers & washers.

Note: two of the leg assemblies are supplied with foot plungers. To have direct access to the foot plungers, install the foot plungers facing the operator or on the same side of the stand that the Horizontal and Vertical scales face.

3. Wearing Gloves, remove the counterweight transportation securing SCREW [See Component Identification STA 01-350MK2 Diagram ]

4. Locate and identify the counterweight cable. [See Component Identification STA 01-350MK2 Diagram ]

**!!!CAUTION!!! AVOID CONTACT WITH THE COUNTERWEIGHT CABLE AT ALL TIMES. CAUTION MUST USED TO AVOID PINCHING YOUR FINGER DURING SET-UP AND NORMAL OPERATION.** The counterweight cable may become frayed during transportation or normal use. When frayed, stop using the stand and immediately replace the cable. Cable strands that separate may become sharp.

### Diagram: A

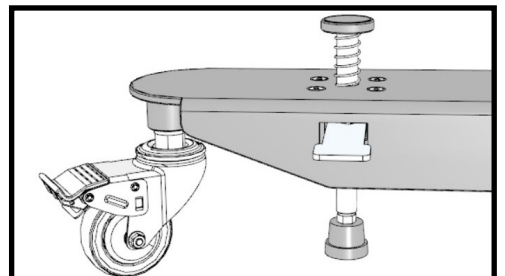
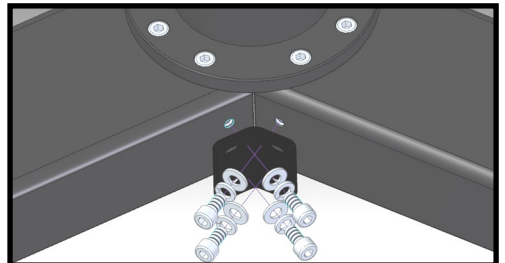
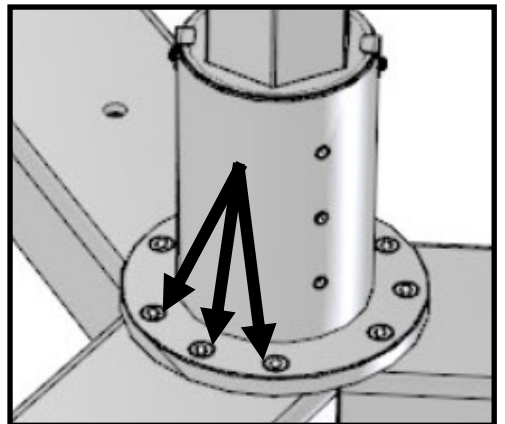
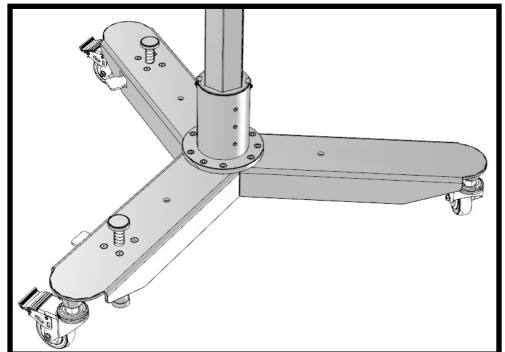

## Assembly Steps:



### **WARNING**

READ ALL  
INSTRUCTIONS PRIOR  
TO ASSEMBLY AND  
OPERATION

5. Together with your Assistant...Wearing Gloves .....Carefully, Slowly raise and lift until the Vertical/ Center Column until it is standing freely on its wheels.

6. Locate the M8 Hex Wrench. Refer to section "Cross Threading Components." Remove the eight M8 x 20 screws from the Vertical carriage. Four M8 screws from the front and two from each side. [DIAGRAM: B indicates the screw locations] Locate the Horizontal Arm/Bar Carriage Assembly. [See Component Identification STA 01-350MK2 Diagram] Together with your assistant. Have your assistant hold the Horizontal Arm/Bar Carriage Assembly in place while you fasten it with the eight M8 x 20 screws. Note the order. [screw, spring washer and then flat washer] Hand tightening with the Hex Wrench is recommended. If you have a torque wrench tighten the M8 screws to 45Nm or 33 lb/ft. not more.

7. Locate the M6 Hex Wrench. Refer to section "Cross Threading Components." Locate the loose Vertical / Brake Knob. Locate the location of Vertical Carriage / Brake Knob See [Transportation Set Screw] [See DIAGRAM: D]. With the M6 Hex Wrench FIRST Remove the transportation set screw and THEN replace with Vertical Carriage / Brake Knob. Turn the Vertical Carriage /Brake Knob fully Clock Wise to secure the vertical carriage in the upper most or "parking position."

**Diagram: B**

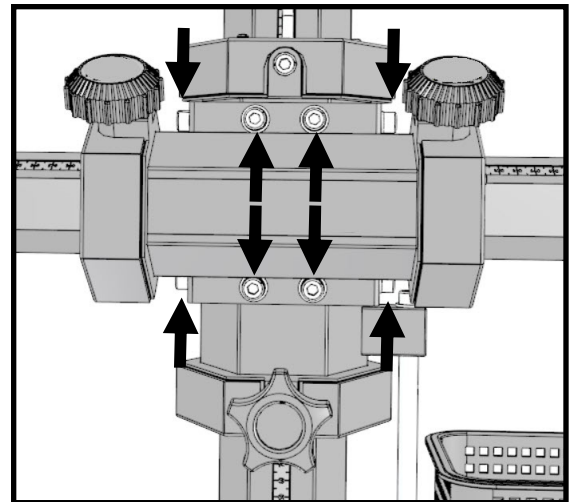

**Diagram: D**

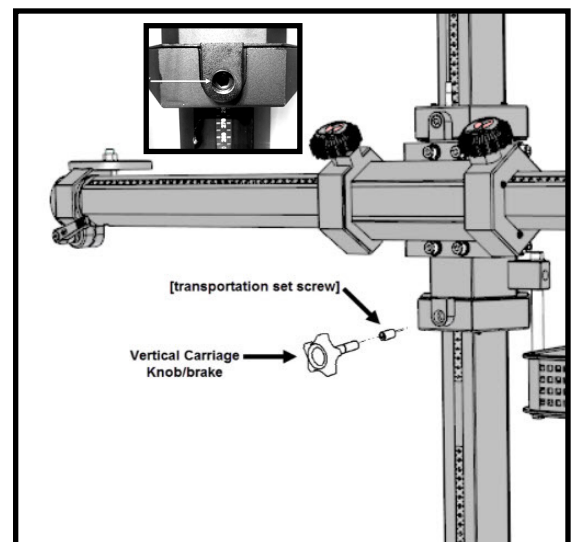

## Assembly Steps:

### **WARNING**

READ ALL  
INSTRUCTIONS PRIOR  
TO ASSEMBLY AND  
OPERATION

 **Studio Titan**  
AMERICA

8. Locate two M8 Hex wrenches. Locate the Basket. Locate the Basket Shaft. [See Component Identification STA 01-350MK2 Diagram] Refer to section "Cross Threading Components." With the first M8 hex key hold the M8 screw at the top of the Basket shaft. With the second M8 hex key loosen the M8 screw at the bottom of the Basket shaft. Attach the Basket to the Basket Shaft. Note the order of fastener connection: [Screw , Flat washer, Basket Plate, Flat Washer]. [See: DIAGRAM: C]

9. CAUTION: [Only with the Horizontal Arm/Bar in the upper most position "parking position".] Slowly release the Vertical Carriage Knob/brake by turning it Counter Clock Wise. This will release the vertical carriage allowing it to travel freely up and down the Vertical Center / Colum. Confirm that the Vertical Carriage is free to move in both directions while using both hands to hold the Horizontal Arm/Bar. Turn the Vertical Carriage Knob/brake fully Clock Wise to secure the vertical carriage.

10. Locate the Two Horizontal Carriage Knob/ Brakes. [See Component Identification STA 01-350MK2 Diagram] Turn the Horizontal Carriage Knob/Brake Counter Clockwise to release and confirm that the Horizontal Arm / Bar is free to move left and right.

STOP SET-UP— Read below— GO TO STEP 11 If anything seems unusual or if the vertical carriage is not moving freely up or down. Stop Set-up and send a few images of the stand to: [info@studiotitanamerica.com](mailto:info@studiotitanamerica.com) for assistance.

### Diagram: C

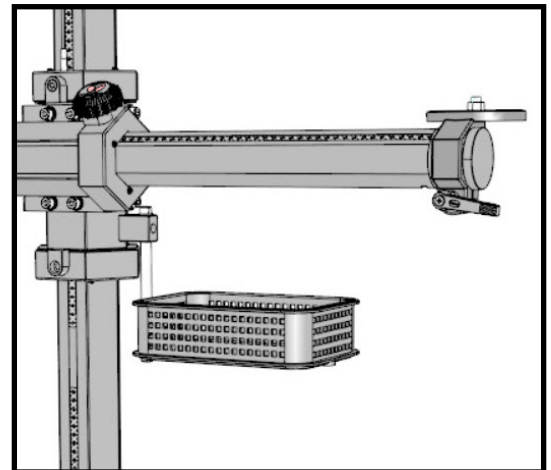
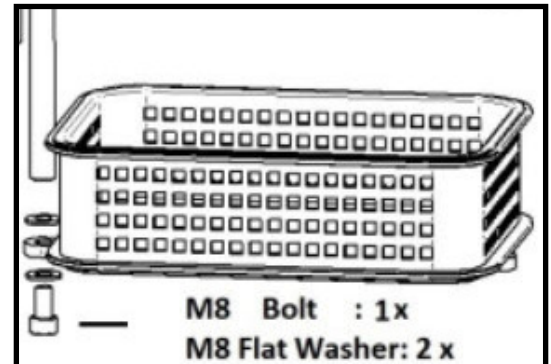

## Use & Maintenance Steps:



### **WARNING**

READ ALL  
INSTRUCTIONS PRIOR  
TO ASSEMBLY AND  
OPERATION

11. HAZARD: Stop and take a moment to understand the effect of the counterweight. HAZARD: The counterweight forces the vertical column to travel towards the top of the Studio Stand. Without a load [Camera, laptop, etc.] on the horizontal Arm/Bar it travels towards the top of the stand. HAZARD: Use the stand with a load [Camera, laptop, etc.]. Always securely "Park" the Vertical Carriage by Turning the Vertical Carriage Knob/brake fully Clock Wise before and after re-positioning or before the stand is unloaded [removing Camera, laptop, etc.].

12. HAZARD: Work in such a way so your always standing behind or in front of the stand. Keep clear of the Horizontal Arm/Bar and accessories. Take extra notice of your body position when you are releasing the Vertical Carriage Knob/brake. With your free hand apply a downward force to the Horizontal Arm/Bar Simultaneously as you release the Vertical Carriage Knob/brake.

13. Storage: Whejn not in use, store with Vertical Carriage in the upper most "Parking Position". Review this manual with all Studio personnel prior to operating the Studio Stand.

14. Re-tighten all fasteners AGAIN. Re-tighten fasteners after the first shoot. Tighten yearly.

## Theory of Operation:



A studio stand is used by professional and commercial photographers to capture images accurately with repeatability. It provides a rigid and stable platform essential for High Resolution Sensors used in DSLR, Medium Format and Large Format cameras and imaging systems. A studio stand reduces vibrations that are present when shooting hand held. Reduced vibration increases image sharpness. It enables the photographer to focus on subject matter and image composition instead of hand holding the camera. It provides creative shooting options using heights and angles that are unachievable when hand holding a camera. It provides the foundation stone that enables the photographer to develop their own technical workflow. As the workflow evolves to include advanced imaging practices, the results can be seen as sharper images.

With an adjustable camera head the user can accurately set up the camera to maintain camera to subject flatness of field in both the vertical and horizontal planes of travel. The flatness of field is maintained as the user moves the stand both vertically and horizontally eliminating perspective distortion.

Shooting tethered with an optional accessory / laptop shelf, reduces floor cabling and allows the photographer to immediately confirm both focus and lighting. A Studio Stand reduces user fatigue. The internal counter balance offsets the weight of the camera and computer. Allowing the user to easily move the camera and computer up and down and left and right using only one hand. This promotes good body ergonomics which can prevent tennis elbow.





**Tip Over Hazard:**

Caution must be used when moving the stand to prevent tip over. Move the stand slowly and avoid uneven surfaces as well as low and high level objects. Additional caution must be used when the Horizontal arm with load (Camera or Laptop Shelf) is used in the upper area above the mid-point of the stand.



**Counterweight Hazard:**

The Horizontal Arm/Bar is connected to a counterweight located inside the Vertical Center/Column. Caution must be used at all times when using the Horizontal Arm/Bar. The Vertical Carriage Knob/Brake must always be tightened to lock the Horizontal Arm/Bar in place. Without a load on the Horizontal Arm/Bar it can travel upwards. When releasing the Vertical Carriage Knob/Brake stand clear of the arms path of movement, firmly hold the Horizontal Arm/Bar applying pressure downwards. Stand back to avoid contact with the Horizontal Arm/Bar when unloaded. Do not remove the load when the Vertical Carriage Knob/Brake knob is released or turned CCW. Unless repositioning the Vertical Center/Column intentionally the Vertical Carriage Knob/Brake must be fully engaged (turned fully clockwise). Store with Vertical Carriage in the upper most "Parking Position."



## STA 01-350MK2 Options and Accessories



• **Options and accessories are available for sale either through your preferred authorized retailer or [studiotitanamerica.com](http://studiotitanamerica.com)**

### **Options:**

STA 01-350LW-10 [3 x 10KG/22lb /ea BOLT UNDER - steel leg weights for 01-350MK2 series]

STA 01-350LW-15 [3 x 15KG/33lb /ea BOLT UNDER - steel leg weights for 01-350MK2 series]

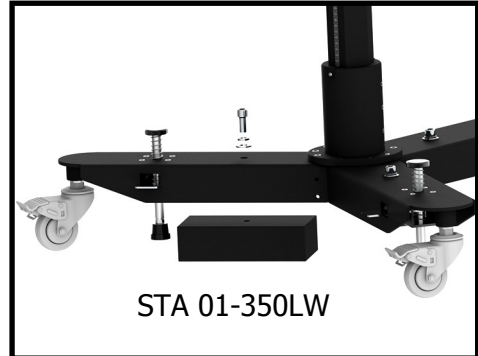

## STA 01-350MK2 Specification & Directions for Materials Recycling



- **Total Height** : 240cm / 94.4 in
- **Working Height Maximum** : 220cm / 86.6 in (measured from Camera Plate to floor)
- **Working Height Minimum** : 50cm / 19.7 in (measured from Camera Plate to floor)
- **Working Width Horizontal - Fully Extended to Left** : 83.5cm / 32.8 in (center of Column to center of Camera plate)
- **Working Width Horizontal - Fully Extended to Right** : 83.5cm / 32.8 in (center of Column to center of Camera plate)
- **Overall Working Width Horizontal - Fully Extended from Left to Fully Extended Right** : 167cm / 65.6 in (center of Camera plate to center of Camera plate)
- **Width** : 100cm / 39.3 in
- **Weight** : 50kg / 110lbs
- **Suggested Wheels** : 01-350-20-024
- **Base Diameter** : 100cm / 39.3 in
- **Recommended General load capacity** : 10kg (22lbs)
- **Camera Plate Hardware**: 3/8th inch - 16 thread
- **Includes two Camera Head Mount Plates and Basket as shown**

### Options:

-Large accessory shelf STA-01-395 for notebook computer

-Small accessory shelf STA-01-397A for notebook computer

-Leg Weight set STA 01-350LW 3 x 7Kg / 15lb/ea. bolt on internal steel leg weights

-STA-01-390 3-way head

Material composition: The Vertical and Horizontal columns are made of aluminum. Counter weight is S20C steel. The nuts and bolts are made of steel. The casters are polyurethane. This product does not contain lead.

**STUDIO TITAN RESERVES THE RIGHT TO MAKE PRODUCT CHANGES AND PRODUCT ENHANCEMENTS. PRODUCTS SUPPLIED MAY NOT BE DELIVERED EXACTLY AS ADVERTISED OR SHOWN ON THE WEBSITE OR IN THE MANUAL.**

- The column box blue outer plastic material is Polypropylene, abbreviated as PP, is a recyclable thermoplastic polymer widely used in many different products. PP is rugged. PP's resin identification code is 5, and it is recyclable.

- Plastic bags are made of LDPE (Low-Density Polyethylene) – Recyclable plastic (check Local Authority) LDPE can be recycled. However, check with your Local Authority to ensure it is recycled in your area. This is described as a hard flexible plastic.

- The Corrugated cardboard box can be recycled at depots, in municipal curbside collection programs and through private recyclers.