

LUCIOUS FLEX USER MANUAL

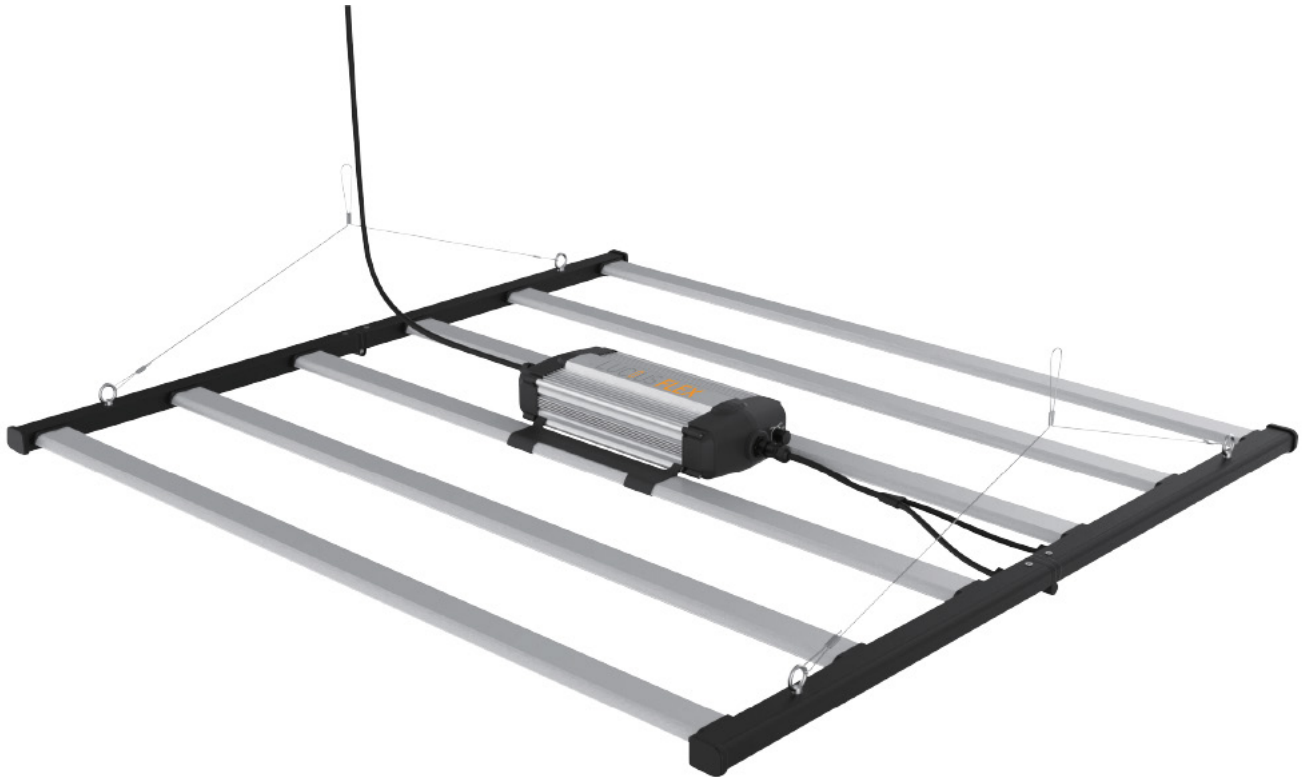

USER MANUAL

LUCIUS FLEX

1. INTRODUCTION

Congratulations for purchasing your LUCIUS FLEX.

Please read and understand this manual in its entirety before using the LUCIUS FLEX. Have an experienced, certified personnel to mount and install this device.

Only use this product as specified within the manual.

2. PRODUCT DESCRIPTION

The 650W LUCIUS FLEX is engineered for horticultural application. Powered by Samsung and Osram, the LUCIUS FLEX equips six LED bars with a high PPF Efficacy (2.8 μ mol/s), and a uniformed coverage area for optimal plant growth. Purposed to accomodate the grower's needs, the LUCIUS FLEX has dimming capability and multiple installation options.

3. CONTENTS

- | | | |
|--------------------|------------------|-----------------------|
| Ⓐ LED driver | Ⓑ LED bars | Ⓒ Solid Decking Mount |
| Ⓓ Lance Hanger | Ⓔ Eye Bolt | Ⓕ Waterfall Mount |
| Ⓔ Input Power Cord | Ⓖ Extension Cord | Ⓖ Interconnect cable |

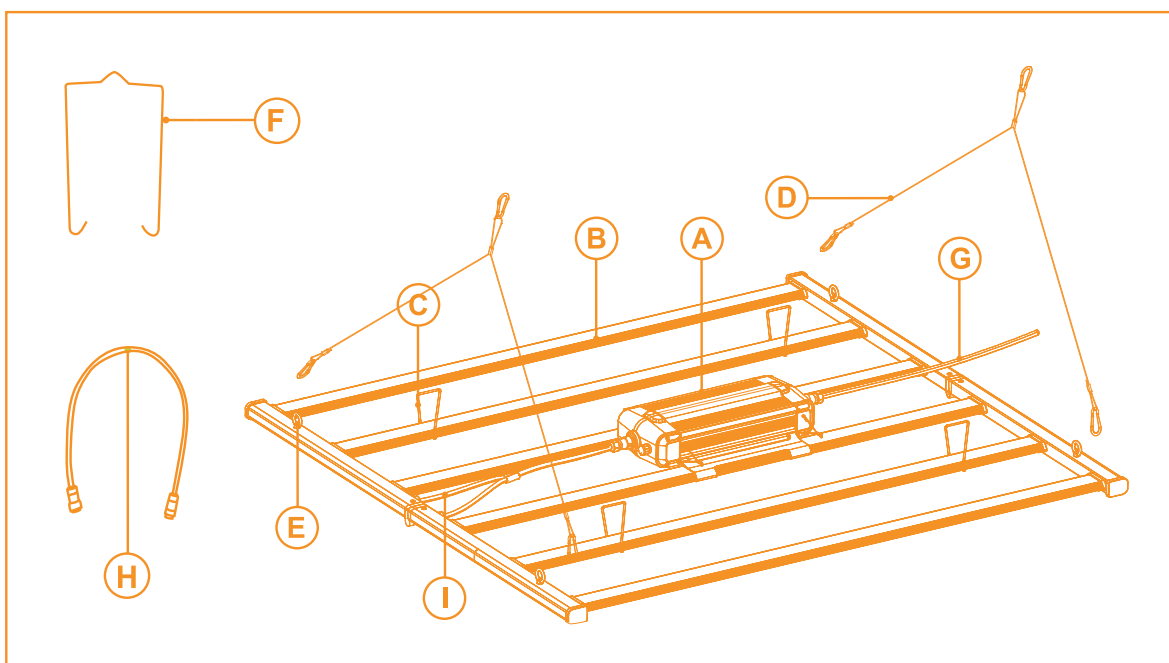

4. PRODUCT INFORMATION AND SPECIFICATIONS

4.1 TECHNICAL SPECIFICATIONS

Spectrum

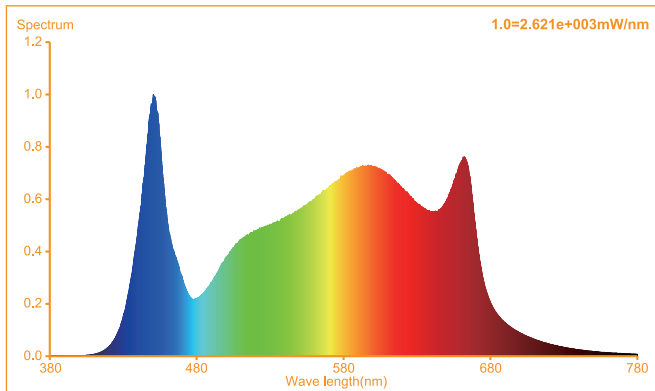

LED Manufacturer	Samsung & OSRAM
Spectrum	Full spectrum
PPF	1800 umol/s
Efficacy	2.8 umol/J
Input Voltage	120V 208V 240V 277V
Input Current	5.38A 3.10A 2.69A 2.33A
Frequency	50/60 Hz
Input Power	650W
Fixture Dimensions	50.13"L x 43.6"W x 2.63"H 127.36cm x 110.76cm x 6.7cm
Weight	27.66lb / 12.55kg
Optimal Temperature	95oF / 35oC
Thermal Management	Passive
External Control Signal	Dimming Option
Dimming Option	40% / 50% / 60% / 80% / 100%
Beam Angle	120o
Lifetime	L90: >54,000hrs
Power Factor	>90%
Waterproof Rate	IP66
Warranty	5-year Warranty

4.2 COVERAGE AREA

PPFD is the number of photosynthetically active photons that fall on a given surface each second.

*Max Coverage Area		
Grow Stage	Flowering	Vegetative
Hanging Height	0.6m 2ft	0.9m 3ft
Length	1.5m 5ft	2.15m 7ft
Width	1.65m 5.4ft	2.2m 7.2ft
Area	2.60m ² 28ft ²	4.8m ² 51ft ²
Max. PPFD umol/s/m ²	725	455
Min. PPFD umol/s/m ²	200	100
Av. PPFD umol/s/m ²	443	248
Uniformity	0.61	0.69

PPFD Intensity Scale
0
100
200
300
400
500
600
700
800

FLOWERING Hanging Height: 0.6m | 2ft

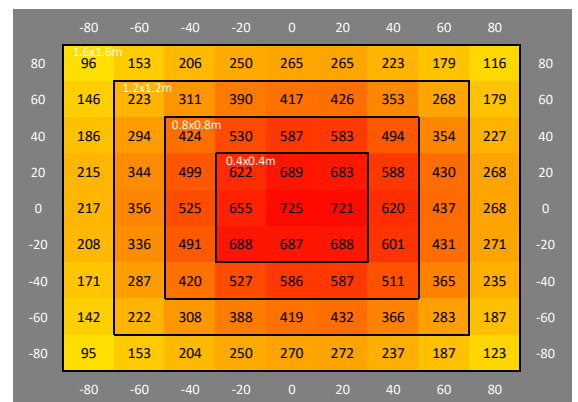

VEGETATIVE Hanging Height: 0.9m | 3ft

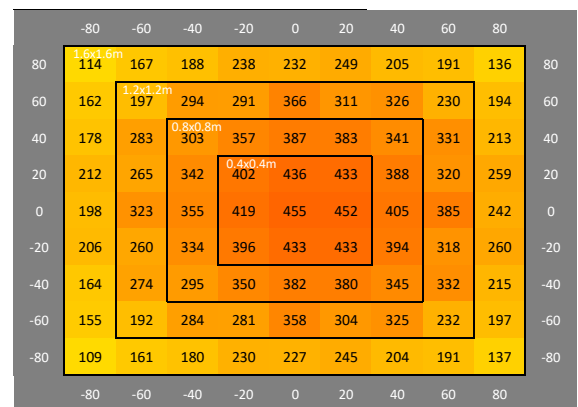

NOTE: To achieve 1000PPFD, the distance between LUCIUS FLEX and a mature plant canopy should be 0.3m | 1ft.

*The Max Coverage Area refers to the area to cover at least 200PPFD for Flowering and 100PPFD for Vegetative.

The PPFD Coverage Area test is conducted in a dark room without reflective walls, floor or ceiling.

LUCIUS FLEX is measured at 100% Light Intensity.

Tested using Apogee MQ-500 Full Spectrum over a 2.4x2.4m grid (graphs depict 1.6x1.6m area).

4.3 ENVIRONMENT

The LUCIUS FLEX works at optimal capacity when the air temperature is between 68 ~ 95° F/20 ~ 35° C.

4.4 DIMENSIONS

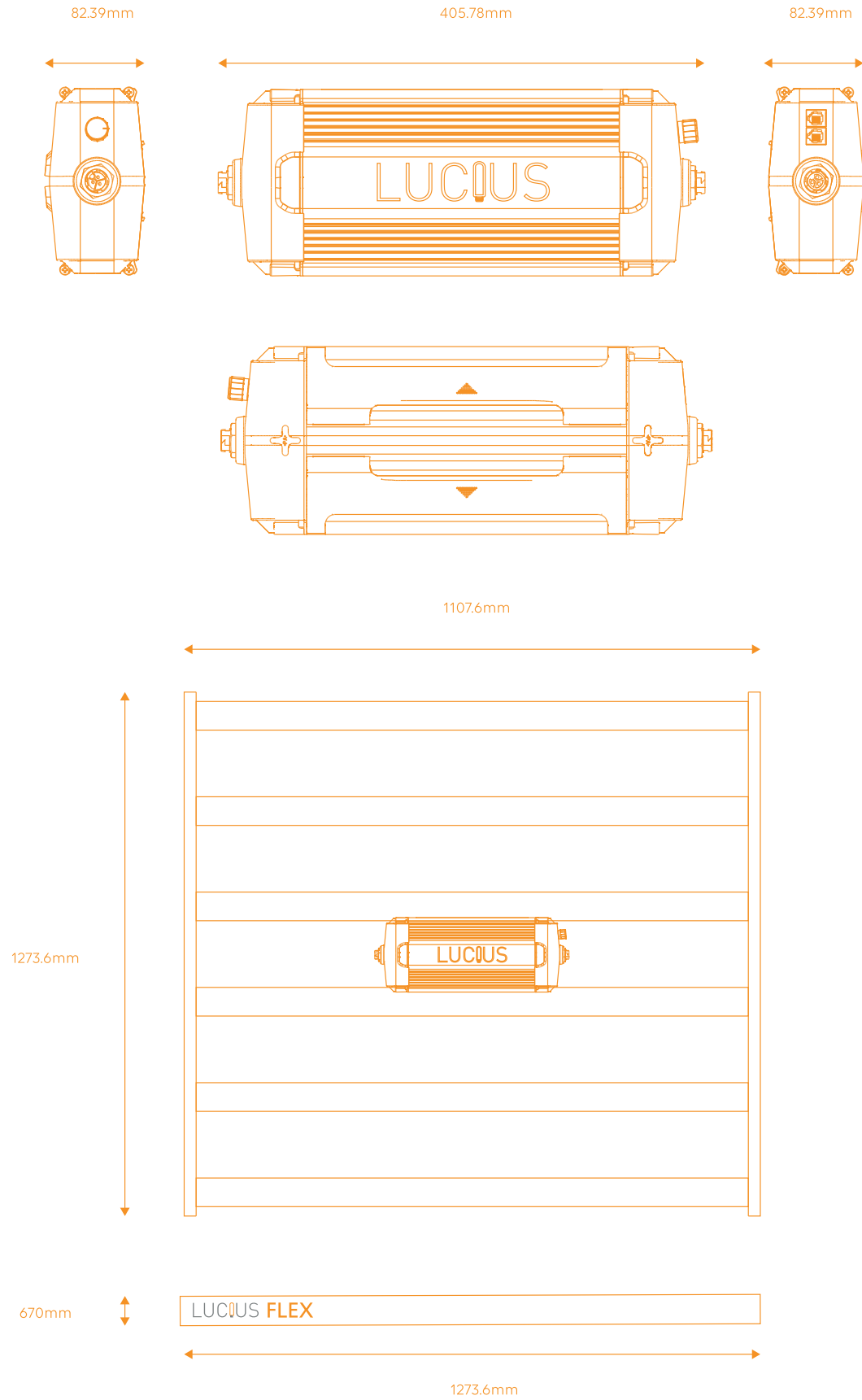

5. INSTALLATION

Warning:

Installing the LUCIUS FLEX should be performed by certified service personnel, in accordance with the applicable local laws and regulations. The installer is responsible for the correct and safe installation of the unit.

Ensure the local cabling can support the voltage and current requirement of the LUCIUS FLEX. Avoid coiled cords and keep main leads separated. This prevents electromagnetic interference. Do not connect or disconnect the LUCIUS FLEX under load.

5.1 INSTALLATION PREPARATIONS

The LUCIUS FLEX fixture comes with lance hangers, solid deck and waterfall mount hanging hardware. In order to mount your LUCIUS FLEX correctly, start by identifying a suitable support structure you can mount your fixture on. Common support structures include pallet racks, trusses, structural channels, Unistrut, and rolling tables. For optimal results, we recommend that two people mount this fixture together.

Warning! Be sure to mount the system to something that can hold the weight of the LUCIUS FLEX.

Note: Ensure the LED bars does not come in contact with sharp objects or force that may damage the LEDs. Be sure to wait at least 30 minutes for the LED bars to cool down before touching them.

5.2 MOUNTING WITH SOLID DECKING MOUNTS

We suggest hanging the LUCIUS FLEX from cross bars in a rack system with solid support, that is able to withstand the weight.

To create proper balance, be sure to position the LUCIUS FLEX parallel to the length of the rack during the setup process.

- Using the solid decking mounts, loop each mount across the crossbar above the LED light bar second from the end of either side of the fixture. Use two decking mounts on either end.

Note: Do not attach mounting hardware to the end light bars, else you may risk damaging the fixture.

- Once all four decking mounts are in place, use two people to lift up the LUCIUS FLEX and mount it on the decking mounts. You can do this by carefully prying apart the hooks until there is enough room to slide the fixture in between. Release the decking mounts and they will hook around the fixture.

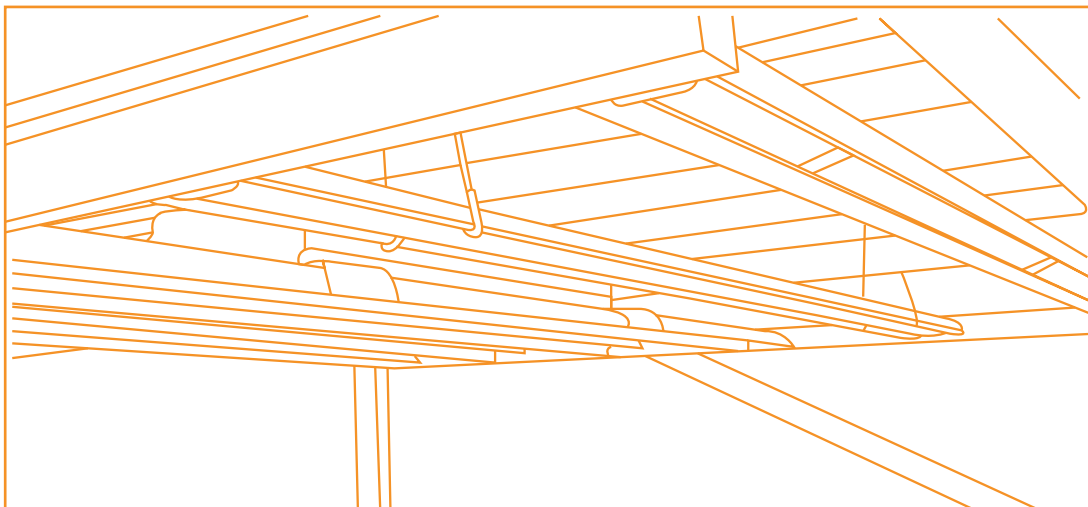

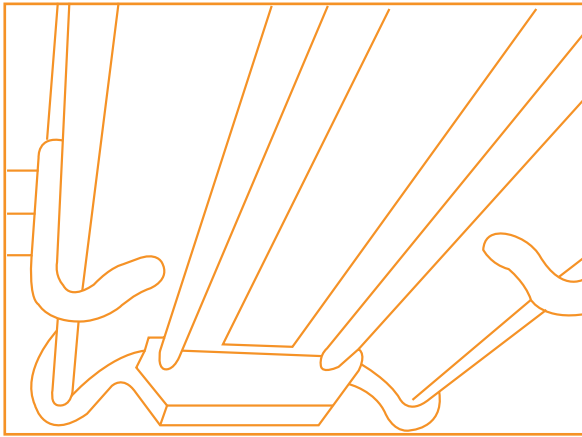

- Adjust the LUCIUS FLEX so that each decking mount makes as much surface contact with the fixture as possible.
- Now that the fixture is secured to the decking mounts, you can adjust the position of the lights by sliding the decking mounts across the crossbars and setting it in the appropriate location for your growing operation.

Note: it is possible to hang the LED ballast separately. Please refer to paragraph 6.4

- If you plan to use the LUCIUS FLEX as a standalone unit, continue to paragraph 6.6.
- If you plan to use a Master Controller, continue to paragraph 6.5.
- If you plan to install multiple LUCIUS FLEX units, simply repeat the steps from paragraph 6.1 and 6.2.

5.3 MOUNTING WITH LANCE HANGERS

We suggest that you hang the LUCIUS FLEX from two points in an area with high clearance, such as a ceiling or other support structures. There are 2 lance hangers included for this purpose.

Before you mount your LUCIUS FLEX, please complete the following steps to attach the power supply to the light bars as outlined in 6.4.

Note: The power supply enclosure MUST be mounted on the center two light bars before hanging with the lance hangers.

- Find the four eye bolts and slide the lance hanger into two of the eye bolts. Gently pull the hanger up from the center of the hanger until the loop snaps into place.
- Once both hangers are securely in place, use two people to lift to the fixture to install the hanging hardware. Be sure to hang from the center of the lance hanger otherwise your fixture may be unbalanced.

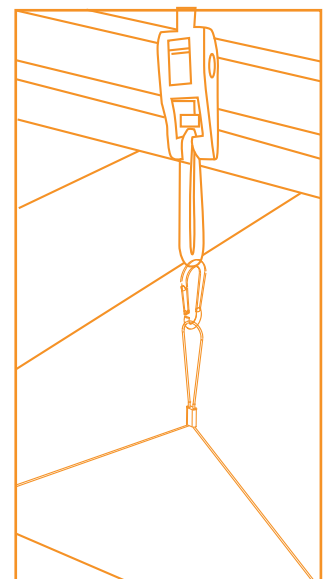
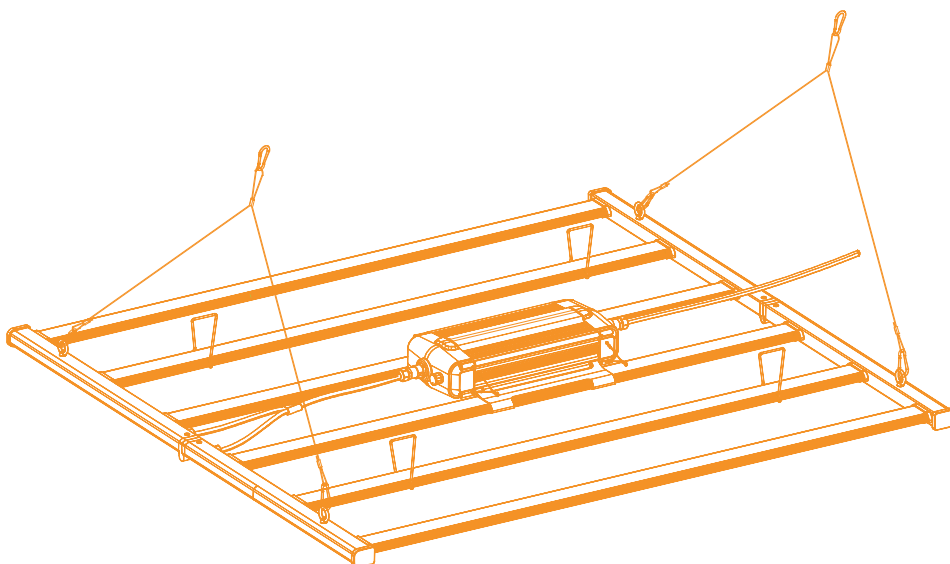

- If you plan to use the LUCIUS FLEX as a standalone unit, continue at paragraph 6.6.
- If you plan to use a Master Controller, continue at paragraph 6.5.
- If you plan to install multiple LUCIUS FLEX units, repeat the steps at paragraph 6.1 and 6.3.

5.4 MOUNTING THE POWER SUPPLY ENCLOSURE

- When unboxing and unfolding the LUCIUS FLEX for the first time, place it on a flush, level surface with the LEDs facing down.
- There are three ways to mount your power supply: attached to the light bars, remote mount to a surface, or hung up with the waterfall mounts.

(1) Open the brackets located at the bottom of the power supply enclosure. Attach the brackets to the center two bars of the LUCIUS FLEX.

- Connect the M19 male adaptor on the LUCIUS FLEX to the M19 female outlet on the power supply enclosure.
- Connect the M19 female adaptor on the input power cord to the M19 male connector on the power supply enclosure.

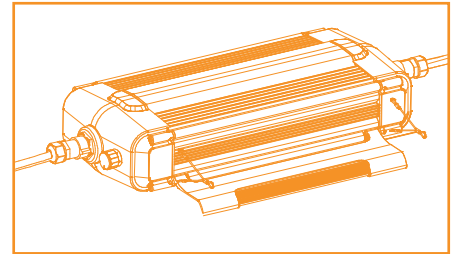

(2) Identify the lock receivers on the underside of the power supply enclosure. Attach the locking receiver to the nail on the wall. Connect the M19 male adaptor on the LUCIUS FLEX to the M19 female outlet on the extension cord, then connect the extension cords of the M19 male connector to the appropriate female outlet on the power supply.

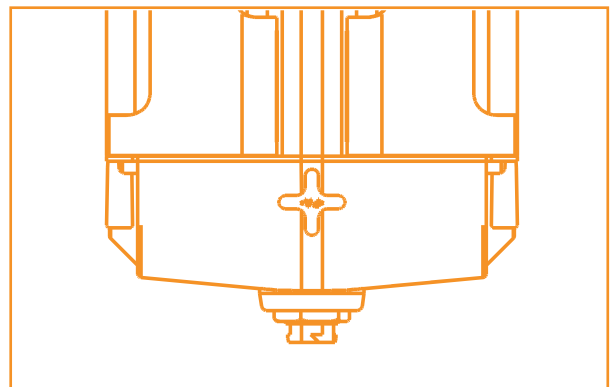

(3) Loop the waterfall mounts on the wire deck or cross bar. Slightly separate the mounting hardware until the hooks slide into the holes on the side of the power supply enclosure.

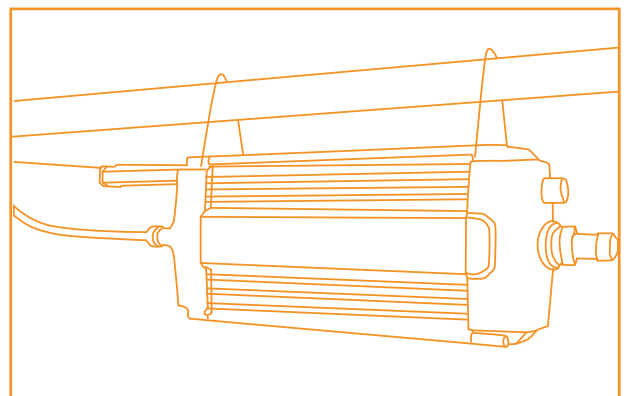

5.5 CONNECTING UP TO 160 LED FIXTURES

- Remove the rubber cap from the input port on the first LUCIUS FLEX.

Note: Keep the rubber cap in a safe place! The rubber cap is necessary to operate the LUCIUS FLEX in a standalone mode.

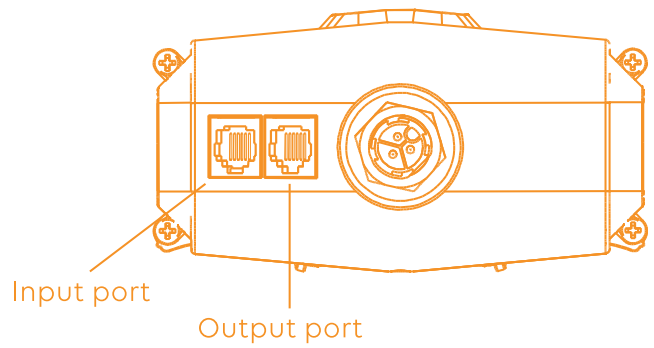

- Set the knob to EXT.

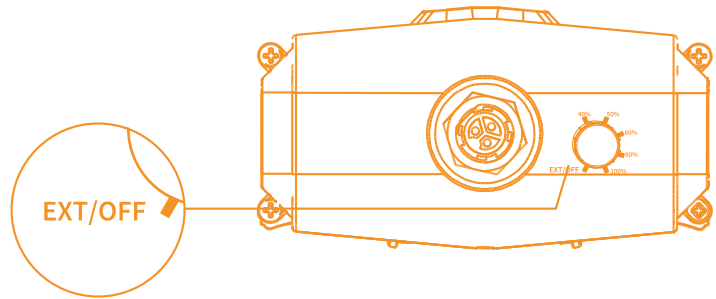

- For your convenience, we have included a black controller cable to connect to the input port on the first LUCIUS FLEX.
- Remove the rubber cap from the input port on the second LUCIUS FLEX.
- Use a black 6pc6 modular jack interconnect cable with an integrated ferrite core to connect the output of the first LUCIUS FLEX with the input of the second LUCIUS FLEX.
- Repeat these steps and you can connect up to 160 LUCIUS FLEX units.

Warning: Ensure the power cord and the controller cables do not touch any of the LED bars, otherwise you may risk an electric shock!

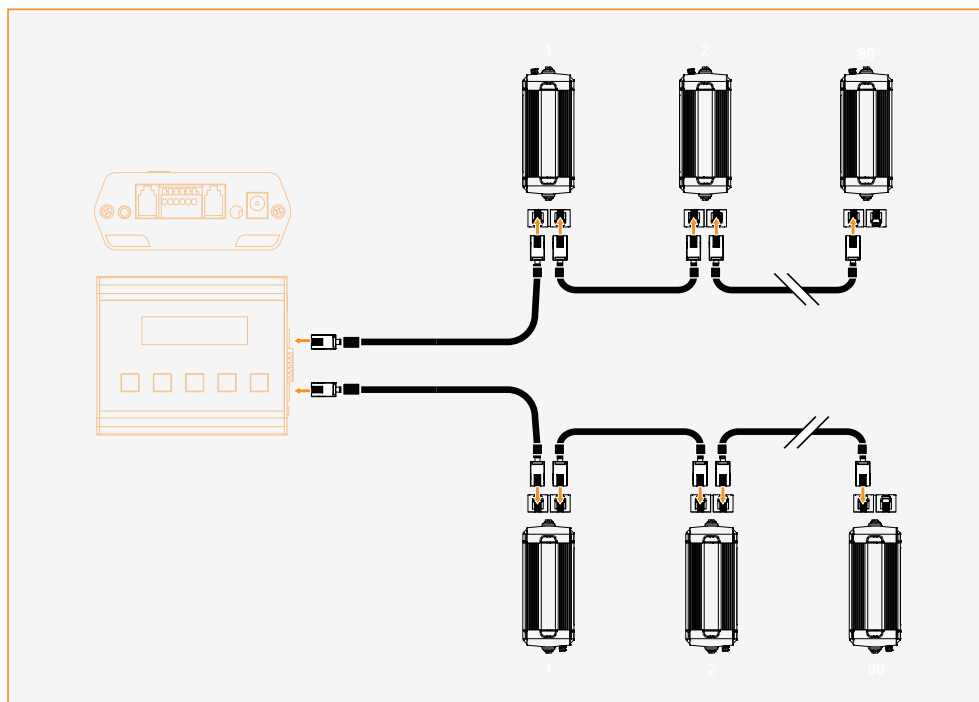

5.6 CONNECTING THE LED FIXTURE TO THE POWER SUPPLY

WARNING:

- Make sure the power supply is switched off before connecting the LUCIUS FLEX.
- Connect the cables according to the local rules, safety regulations and electrical code.
- Ensure the external switching gear can cope with the inrush of electric current for the LUCIUS FLEX unit/s (reference paragraph 3.1 for further details). Always use a double pole contactor that is suitable for switching a capacitive load.
 - Connect the M19 female connector on power cable to the male connector on the power supply enclosure.
 - Connect the power cable to the power supply.
 - Switch on the power supply.

CAUTION:

Ensure the cord is not coiled and does not touch any hot surfaces.

6. INSPECTION AND MAINTENANCE

WARNING:

- Disconnect the LUCIUS FLEX from the power supply before performing any maintenance.
- Do not connect or disconnect the LUCIUS FLEX while it is under load.
- Do not open or disassemble the LUCIUS FLEX - it contains no serviceable parts inside. Opening the unit can be dangerous and will void the warranty.
- Always allow for a cool down period of at least 30 minutes before touching the LED bars.

CAUTION:

- Do not clean the LUCIUS FLEX with detergents, abrasives or other aggressive substances.
- Please regularly check the unit for dust or build-up. Clean if necessary. Contamination may cause overheating and decrease performance. Clean the outside of the unit using a dry or damp cloth.
- Regularly check the cables of the LUCIUS FLEX to ensure it is undamaged.

7. STORAGE AND DISPOSAL

- Store the LUCIUS FLEX in a dry and clean environment, with an ambient temperature of $-4 \sim 185^{\circ} \text{F}$ / $-20 \sim 85^{\circ}$.
- The product must not be discarded as unsorted municipal waste, but must be collected for the purpose of treatment, recovery and environmentally sound disposal.

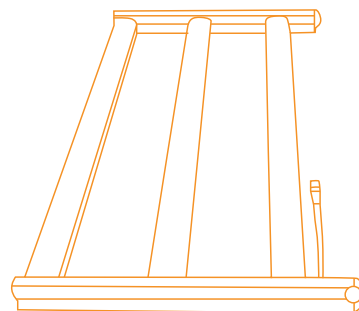
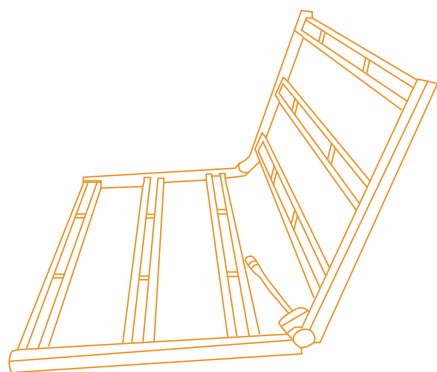

8.SAFETY RECOMMENDATIONS AND WARNINGS

Warning:

Please read the following instructions carefully before using or working with the product!

- Always adhere to local rules and regulations when installing or using the LUCIUS FLEX.
- Do not open or disassemble the LUCIUS FLEX - it contains no serviceable parts inside. Opening or modifying the LUCIUS FLEX can be dangerous and will void the warranty.
- This product may cause interference to radio equipment and should not be installed near maritime safety communications equipment or other critical navigation or communication equipment operating between 0.45 ~ 30 MHz.
- Do not use the LUCIUS FLEX when either the unit or its power cord are damaged. Replace the power cord only with the original certified cords.
- Modifications to the cords can lead to unwanted electromagnetic interference and other effects; this will void the warranty and nullify any compliance with legal regulations.
- Do not expose the LUCIUS FLEX to:
 - Condensation, humidity, heavy mist, fog, or direct spray;
 - Ambient temperatures outside the specified range;
 - Dust and/or contamination;
 - Direct sunlight during use or HID light that could heat up the power supply enclosure.
- Always disconnect the LUCIUS FLEX from mains before performing any maintenance.
- Always allow for a cool down period of at least 30 minutes before touching the LED bars. Touching the LED bars when the unit is lit or immediately afterwards will result in severe burns!
- Do not use the LUCIUS FLEX near flammable, explosive, or reactive substances. The unit reaches temperatures of >104o F / 40oC.
- Do not use sulfur vaporizers or water misters.
- The installation and use of this unit is the responsibility of the end user. Incorrect use or installation can lead to malfunction and failure of the unit. Any damage to the unit as a result of incorrect installation or use revokes the warranty.

9. WARRANTY

The company warrants the mechanical and electronical components of this product and guarantees the materials and workmanship is free of defects if used under normal operating conditions, for a period of three years from the original date of purchase.

If you find that there are any defects with this product that relate to either the workmanship or the materials but are not due to improper use or user error, the company shall, at its discretion, either replace or repair the product. The date of the limited warranty shall apply to the replacement from the date of the purchase of the initial product for three years.

LIGHTING THE WAY

We at Lucius are passionate gardeners who take pride in creating perfect solutions for your garden.

With the help of science and technology, our goal is to save you on power consumption by improving ballast efficiency and PPF Efficacy with our commercial greenhouse fixtures.

Learn more about lighting and how it can optimise your system.

Contact Western Electrical: info@westernelectrical.com.au

**WESTERN
ELECTRICAL**

LUCIUS FLEX

