

# Installation Requirements

## Slayer Steam EP 2-group

### Counter

- Width: 35 inches / 89 centimeters
- Depth: 28 inches / 71 centimeters
- Height: 17 inches / 43.2 centimeters
- Weight: 220 lbs / 100 kg (tanks filled)  
Measurements do not include overhanging components: portafilters.

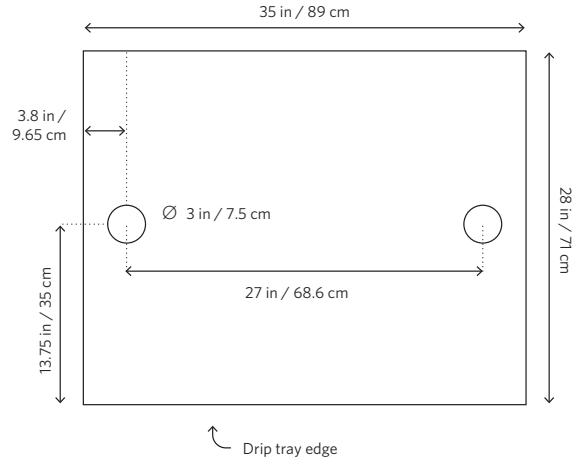

### Water

- 3/8-inch BSP dedicated cold water line with shutoff valve (in North America, 3/8-inch compression fitting is included)
- Required incoming water pressure: 3 Bar min, 5 Bar max
- Water hardness cannot exceed 50ppm, otherwise a water softener is needed

### Power

- Single-phase: 220-240 v, 50/60 hertz, 26 a, 4.7–5.6 kW
- Three-phase: 380-415 v3n, 50/60 hertz, 17 a, 4.9–5.7 kW
- Receptacle: Nema 6-50

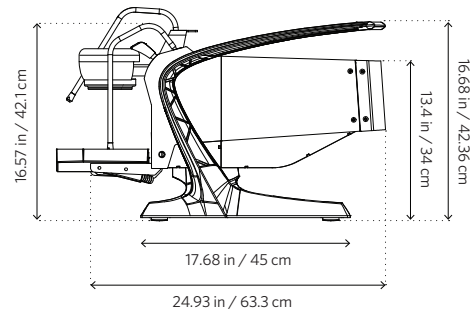

### Drain

- Open gravity drain located within 4 feet / 1.2 meters of the machine
- Two (2) drain hoses: 7/8-inch outside diameter, 5/8-inch inside diameter (2.2-centimeter outside diameter, 1.6-centimeter inside diameter).
- Ensure drain line is always sloping downwards

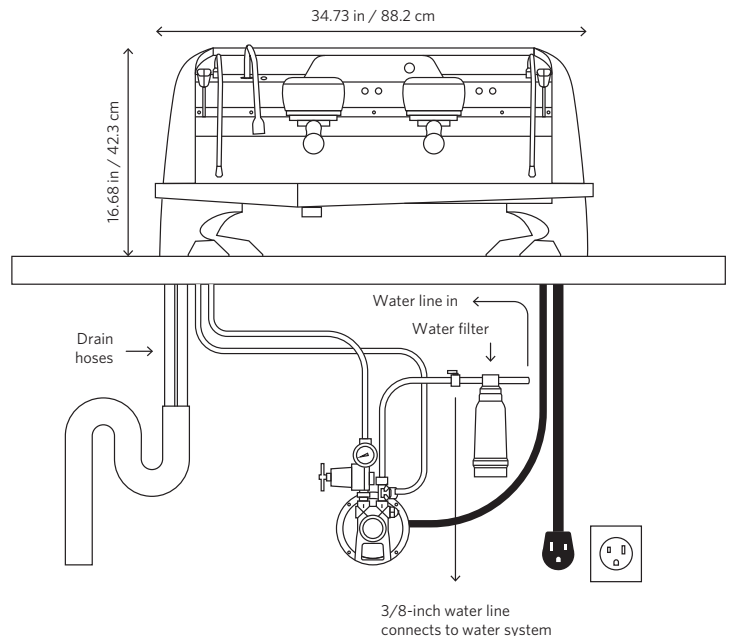

STEAM<sup>EP</sup>

