



LIBERTY
FLAGPOLES

www.libertyflagpoles.com | 1-800-314-2392

INSTALLATION INSTRUCTIONS EH-100

EXTERNAL HALYARD FLAGPOLE SYSTEM

GROUND SET and SHOE BASE



External Halyard Stationary Truck



External Halyard Single Revolving Truck



External Halyard Double Revolving Truck

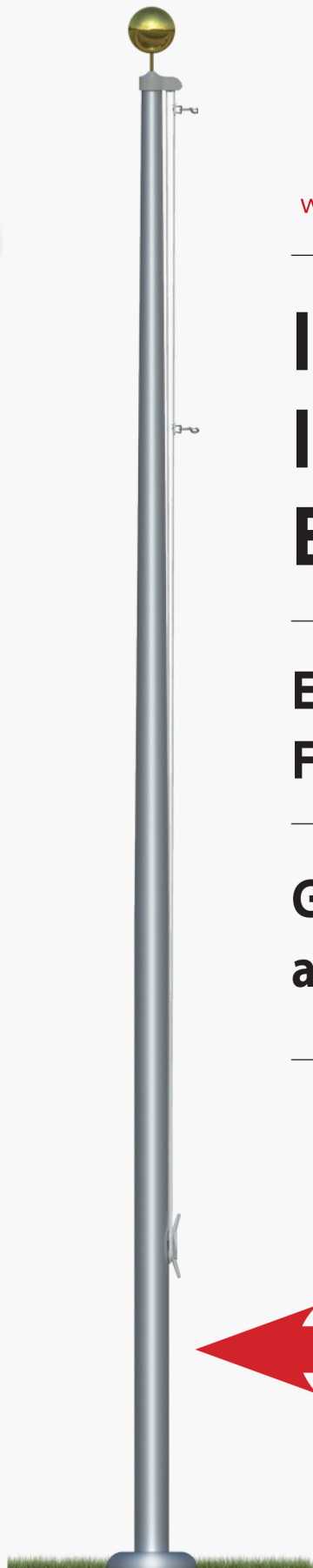

WARNING:

To prevent staining the flagpole must be stored in a dry place OR all packaging must be removed immediately after receiving shipment.



FOR QUICK AND PROFESSIONAL INSTALLATIONS READ ALL INSTRUCTIONS BEFORE PROCEEDING

Lay out all flagpole components. If a part is missing from the attached parts diagram, please contact your American Flagpole Dealer for replacement.

STEP 1 - Remove all wrapping materials and place unwrapped flagpole on cribbing or other wood support on ground (preferably in a covered dry area). For **MULTI-SECTION** flagpoles, carefully lay sections out in proper order, grouping flagpole sections with like match marks. Sections **MUST BE STRAIGHT & LEVEL** while sliding together. Line up match mark numbers, imprinted at each section, for proper fit. Lightly sand away any burrs that may be present on the male section or in the upper section of the joint. A small amount of lubrication (*silicone or dish washing liquid – by others*) may be applied to the male portion of the joint for easier fitting. Start with the bottom sections and work toward the top. Begin sliding the two sections, rolling the flagpole by 180° with every 2 to 3 inches to facilitate an easier fit. If extreme difficulty is found in fitting the first 6 inches together, pull back apart and cool the male section with ice for several minutes. A sledgehammer and block of wood (to protect the flagpole from direct impact) may be necessary on larger poles to complete the assembly of joints. American Flagpole suggests the use of an epoxy adhesive for flagpoles 60' and greater.

STEP 2 - Identify parts and place them along the flagpole according to the parts diagram.

STEP 3 - Starting with the finial ball (*PART A*), screw the ball's spindle into truck (*PART B*). Do not grip ball to tighten, grip spindle/rod with vise grips and tighten. Tighten all nuts and set screws. An epoxy or Loc-tite type product (*by others*) is recommended on all connections.

STEP 4 - Attach the truck (*PART B*) with ball by screwing into the threaded top of the flagpole. Do not epoxy spindle of truck. If truck (*PART B*) is a stationary truck, be sure to secure all set screws.

STEP 5 - Feed the polypropylene rope (*PART C*), around the pulley of the truck (*PART B*) and down the side of the flagpole to the cleat area. Tie both ends together forming a complete loop. Space the snap hooks and neoprene covers (*PART D*) at equal distance on either side of the knot to accommodate flag size. Refer to parts diagram for snap hook attachment.

STEP 6 - Fasten cleat(s) (*PART E*) into position using the self-drilling screws provided. **IMPORTANT NOTE:** The cleat(s) are typically installed at 4'-6" above the finished grade. When installing the cleat prior to setting the pole, **MAKE SURE TO ALLOW FOR DEPTH OF SLEEVE.** Use cleat as template for installation. A pilot hole or drilling oil may be used to facilitate installation. If a second cleat is desired, it is typically mounted at 180 degrees from the first. For installations involving more than two cleats, refer to shop drawings for correct positioning and orientation. For cleat box installation, use drill and tap kit to prepare holes in shaft. Align box and cleat over holes, and fasten to flagpole using provided bolts.

STEP 7 - Before standing flagpole, slide the flash collar (*PART F*) up from bottom and secure at the location of the cleat holes with tape on underside of flash collar to prevent slipping.

STEP 8 - Stand flagpole into previously installed ground sleeve (Ground Set Installation) or onto anchor bolts (Shoe Base Installation). This may require the use of a crane or backhoe for larger flagpoles. Always choke multiple section poles below lowest joint as a safety precaution. Caution: During installation, the flagpole should be assembled as close as possible to the final support point. Professionals experienced in such installations should perform rigging and lifting. During lift, keep clear of the area and reach of the flagpole path. Do not pass flagpole overhead. When installing multi-piece flagpoles, arrange the rigging for the lift in such a way that weight of the flagpole sections is supported from the bottom of the flagpoles so that the flagpole joints are pushed together, not pulled apart, during the lift. Keep clear of power lines.

STEP 9A (GROUND SET) - After inserting flagpole into ground sleeve (galvanized corrugated 16 gauge steel tube), plumb flagpole with wooden wedges (by others). Fill space between ground sleeve and flagpole with tamped dry sand. Fill ground sleeve 6" to 8" at a time and tamp as you fill. Fill ground sleeve with sand to about 2" from top. Then cap off with waterproof cement. For PVC ground sleeve, insert flagpole into plastic sleeve, turn to align truck assembly with the wind, plumb pole, fill remaining void with dry sand, and top off with thin layer of waterproof cement or caulking.

STEP 9B (SHOE BASE) - After placing the flagpole on top of the anchor bolts, install flat washer, lock washer, and hex nut. Tighten nut and verify that all threads are fully engaged. *NOTE: An installation using "double nuts" is not recommended by American Flagpole.*

STEP 10A (GROUND SET) - After waterproof cement has dried slide flash collar (PART F) down into position and caulk joint with matching color silicone to seal the space between the flagpole and the flash collar.

STEP 10B (SHOE BASE) - After the nuts have been tightened, slide flash collar (PART F) down into position and caulk joint with matching color silicone to seal the space between the flagpole and the flash collar.

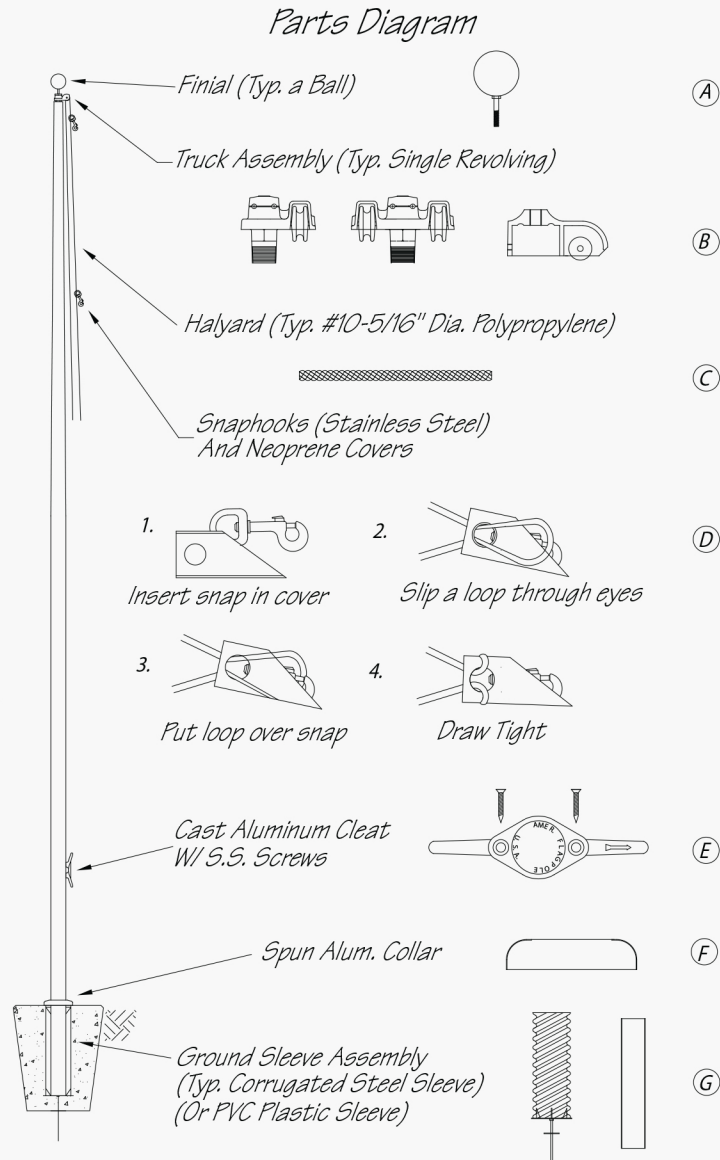

GROUND SLEEVE INSTALLATION

Ground Sleeve with Steel Lighting Spike Installation

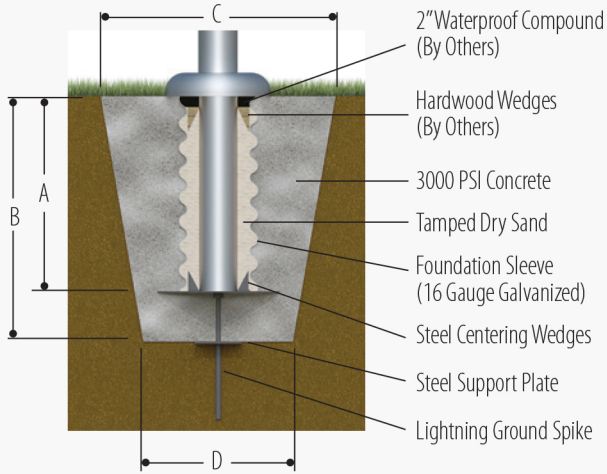

EXPOSED MOUNTING HEIGHT	A	B	C	D
20'-0"	2'-0"	2'-6"	30"	24"
25'-0"	2'-6"	3'-0"	36"	24"
30'-0"	3'-0"	3'-6"	36"	24"
35'-0"	3'-6"	4'-0"	36"	30"
40'-0"	4'-0"	4'-6"	45"	36"
45'-0"	4'-6"	5'-0"	45"	36"
50'-0"	5'-0"	5'-6"	50"	42"
60'-0"	6'-0"	6'-6"	60"	48"
70'-0"	7'-0"	7'-6"	60"	48"
80'-0"	8'-0"	8'-6"	72"	48"

PVC Ground Sleeve Installation

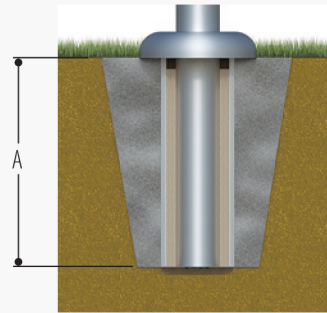

NAAMM's Metal Flagpole Manual offers basic suggestions on foundation measurements in firm, dry soil only using dry tamped sand and 3000 PSI concrete. Soil conditions vary by site. Exact foundation requirements should be verified by a Structural Engineer with knowledge of soil conditions in your locality.

SHOE BASE FOUNDATION INSTALLATION

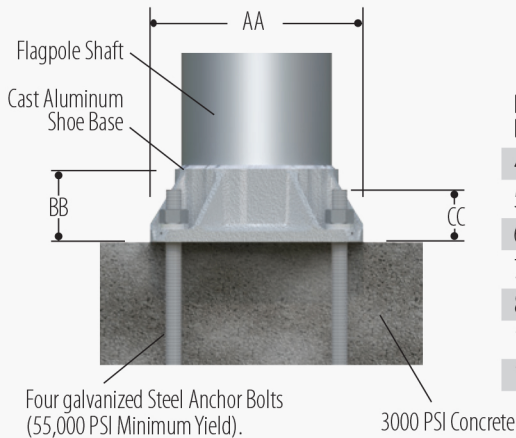

BUTT DIAMETER	AA BASE SQUARE	BB BASE HEIGHT	CC BOLT PROJECTION	BOLT DIAMETER	BOLT CIRCLE DIAMETER
4"	7-1/2"	3"	2"	3/4"	6-1/2" - 8"
5"	7-1/2"	3"	2"	3/4"	7 1/2" - 8"
6"	9-3/4"	3-1/2"	2-3/4"	1"	9" - 10"
7"	10-1/2"	3-11/16"	2-3/4"	1"	10" - 11"
8"	11-1/4"	3-15/16"	2-3/4"	1"	11" - 12"
10"	14"	4-7/8"	3-1/4"	1"	14" - 15"
12"	17"	8"	3-3/4"	1-1/4"	16" - 18"

Shoe Base Foundation Installation

