

## Model ECX20 - External Single Halyard

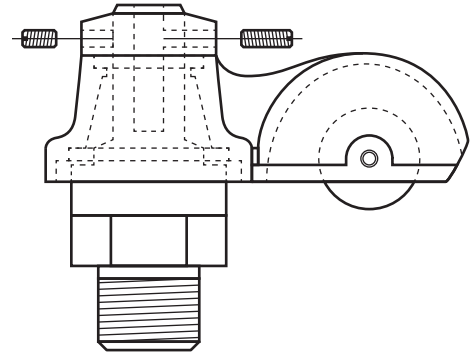
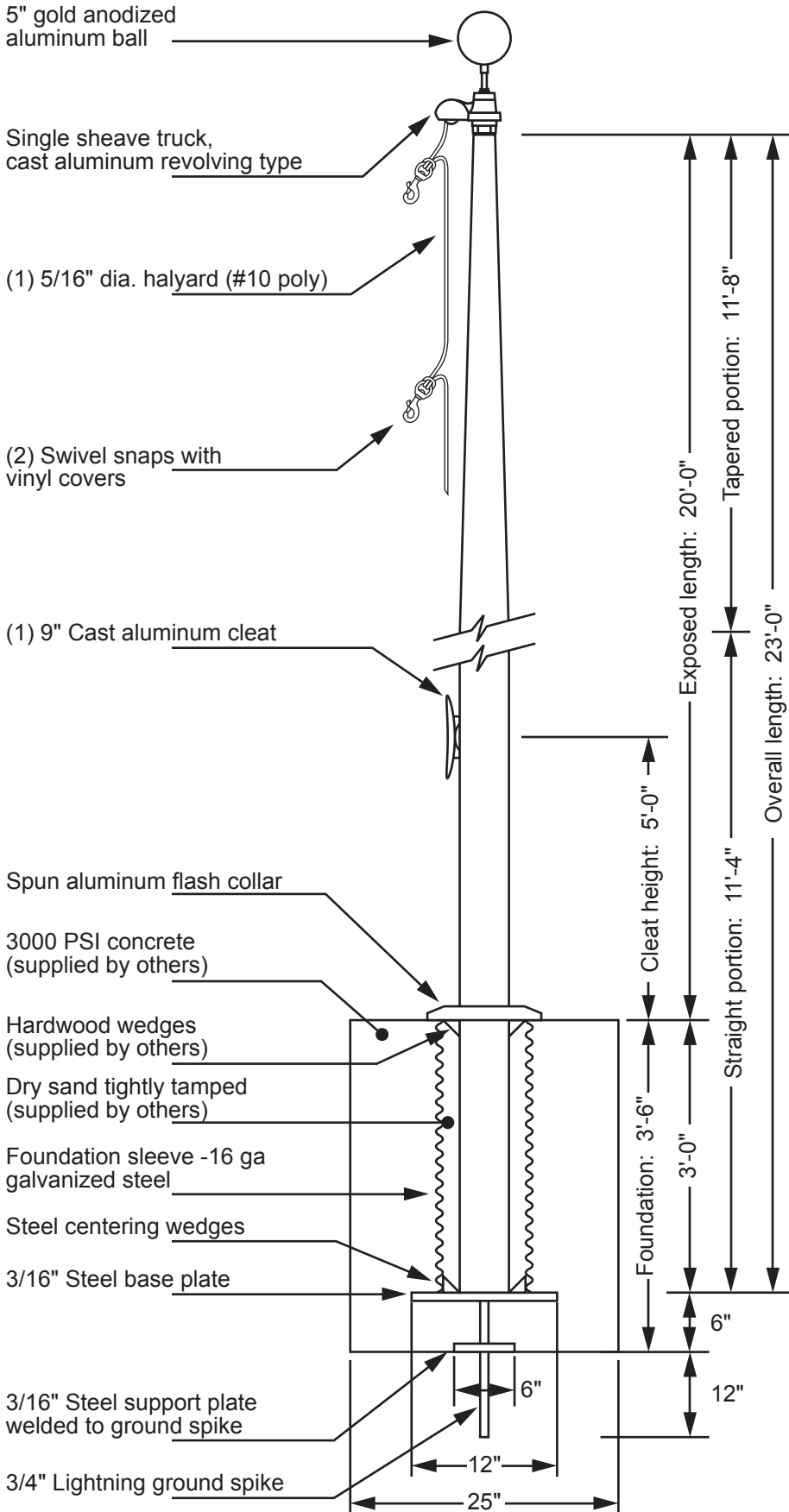

**Single Sheave Truck Detail**  
 Revolving truck  
 Cast aluminum body  
 Stainless steel ball bearings  
 Nylon sheave  
 Cast aluminum spindle

Project:  
 Location:  
 Contractor:  
 Customer:

Date:  
 Job:  
 Revision:

Exposed Height \_\_ 20'-0"  
 Overall Height \_\_ 23'-0"  
 Butt Diameter \_\_ 5"  
 Top Diameter \_\_ 3"  
 Wall Thickness \_\_ .125"  
 Ships in 1 section

Ground Set Tapered  
 Aluminum Flagpole  
 ALLOY 6063T6  
 80 grit polish  
 FINISH:

