



©2016 AquaTru™, LLC. All Rights Reserved. 4.16/R5



**owner's  
manual**

# TABLE OF CONTENTS

<b>SAFETY INSTRUCTIONS</b>	<b>2</b>
<b>FEATURES</b>	<b>3</b>
<b>MAIN PARTS</b>	<b>5</b>
<b>WATER FILTRATION PROCESS</b>	<b>6</b>
<b>INSTALLATION</b>	<b>7</b>
<b>HOW TO USE</b>	<b>9</b>
<b>CLEANING</b>	<b>10</b>
<b>MAINTENANCE/FILTER REPLACEMENT</b>	<b>11</b>
<b>TROUBLESHOOTING</b>	<b>12</b>
<b>ONE-YEAR LIMITED WARRANTY</b>	<b>14</b>
<b>ARBITRATION AGREEMENT</b>	<b>15</b>



Thank you for purchasing the AquaTru™ reverse osmosis home water purifier! This state of the art water purification system will greatly improve the quality and taste of your water. AquaTru™ is a healthy choice and a great way to save money while being environmentally friendly. We want you to be fully satisfied with your AquaTru™ water purifier. That's why the AquaTru™ comes with a one-year limited warranty.

Once you've experienced the purity of AquaTru™ water, visit us at our website to find out more ways to improve the quality of your water and your life with our premium products and upgrades.

Please be sure to read the following instructions carefully before use to ensure optimal performance and safety.

**[www.aquatruwater.com](http://www.aquatruwater.com)**

AquaTru™, LLC  
1392 Sarah Place, Ste. B  
Ontario, CA 91761  
800.220.6570



## SAFETY INSTRUCTIONS

### READ AND SAVE THESE INSTRUCTIONS

**WARNING: IF NOT OBSERVED, SERIOUS PHYSICAL INJURY OR PROPERTY DAMAGE MAY OCCUR AS A RESULT.**

**WARNING: Use only on municipally treated water or other supply known to be microbiologically safe.**

- Connect only to a circuit that is protected by a ground-fault circuit-interrupter (**GFCI**).
- Do not repair, disassemble, or modify.
- This appliance is not intended for use by persons (including children) with reduced physical, sensory or mental capabilities, or lack of experience and knowledge, unless they have been given supervision or instruction concerning use of the appliance by a person responsible for their safety.
- Children should be supervised to ensure that they do not play with the appliance.

### READ ALL INSTRUCTIONS BEFORE OPERATING THE AquaTru™

- Use or place the unit on a level area and do not apply force to the unit.
- Periodical filter replacement is a prerequisite for obtaining clean water.
- Do not use filtered water for the water exchange of an aquarium or a fishbowl.
- Do not use with water that is microbiologically unsafe or of unknown quality without adequate disinfection before or after the system.
- Hand wash only. **Not dishwasher safe!**
- Household use only.
- Do not operate below 40° F.
- When placing AquaTru™ on a kitchen countertop, always avoid placing near hot surfaces like stoves and ovens.



## FEATURES

### Advanced 4-Stage Purification System

The AquaTru™ water purification system provides powerful quadruple purification performance utilizing reverse osmosis technology.

### Cost Savings Efficiency

Avoiding bottled water cost by creating your own clean water, and long lasting filters all add up to significant savings over the life of the product.

### One-Touch Water Dispensing

Simple intuitive one-touch controls for dispensing water.

### Space Saving and Compact Design

Efficient and elegant countertop design takes up minimal space in the kitchen.

### Quick Filter Replacement

Easy access to the filter bay to replace filters. No tools required!

### Easy DIY Installation

Ready to use in less than 10 minutes.





## MAIN PARTS

1. Side Panel
2. Pre/Carbon Filter (Part# **AT3001**)
3. Reverse Osmosis Filter (Part# **AT3002**)
4. VOC Carbon Filter (Part# **AT3003**)
5. Filtered Water Tank
6. Unfiltered Tap Water Tank
7. Dispensing Button
8. Display
9. Power Adapter (universal voltage)

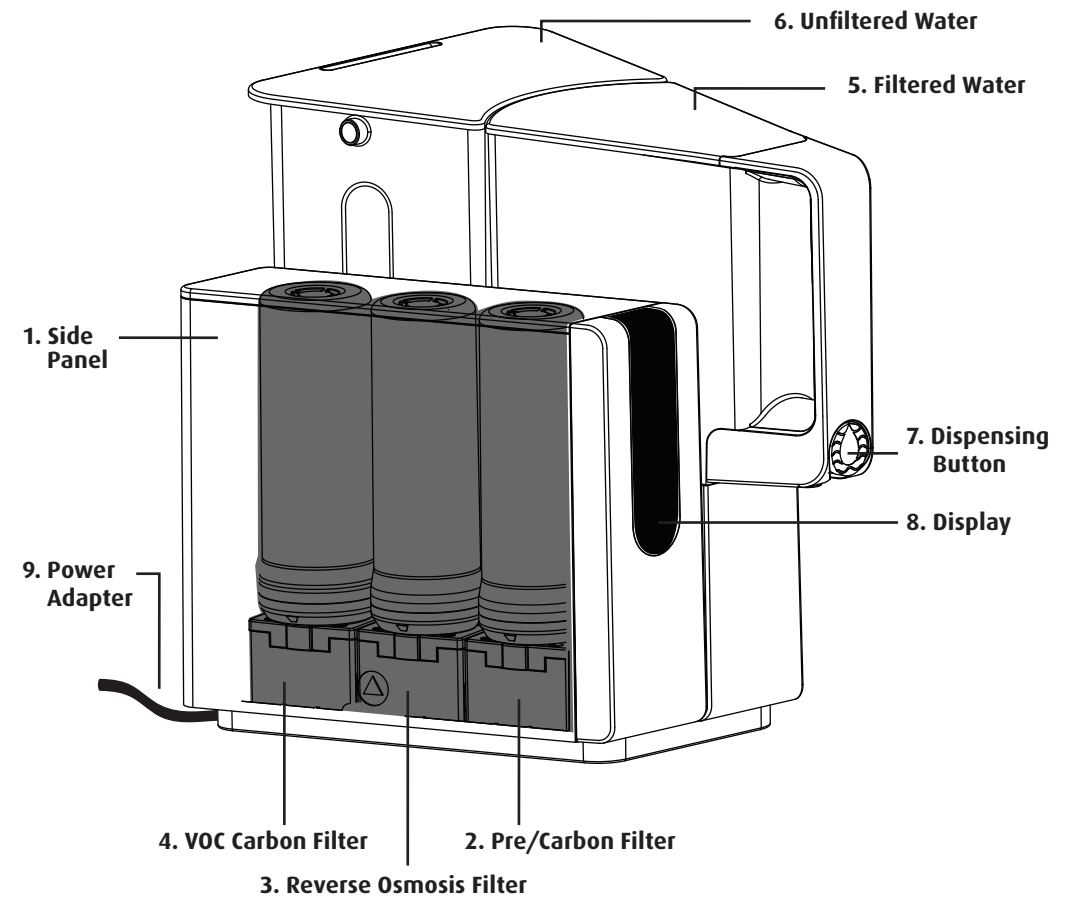

## WATER FILTRATION PROCESS

### Quadruple Action Purification:

#### 1 Dual Stage Pre Filter

The pre filter reduces sand, silt, sediment, rust and particles from water. Activated carbon eliminates chlorine taste, removes odors and conditions the water before it is treated by the reverse osmosis membrane.

#### 2 Reverse Osmosis Filter

The RO membrane reduces impurities from the water down to 1/10000 of a micron.

#### 3 VOC Carbon Filter

This carbon filter is made of high quality activated carbon. It is designed to remove volatile organic compounds, enhance the taste and prepare the water for consumption.

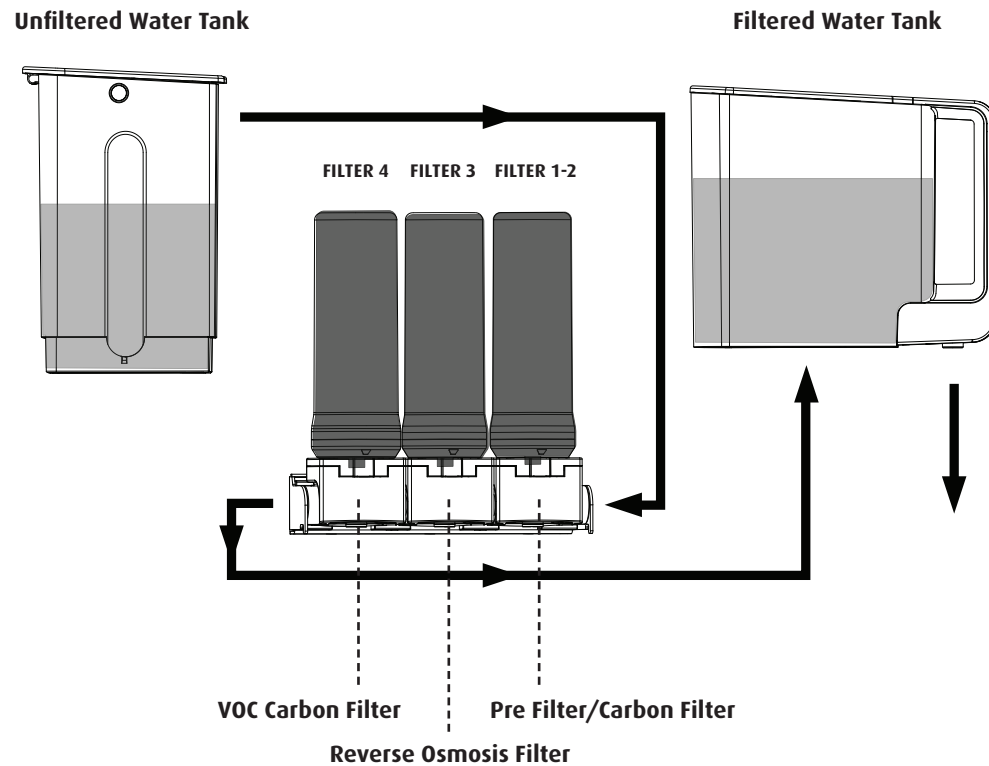

## INSTALLATION

- 1 Remove all parts from the box.
- 2 Clean and rinse both water tanks before using unit.
- 3 Open side panel by lifting up from bottom.

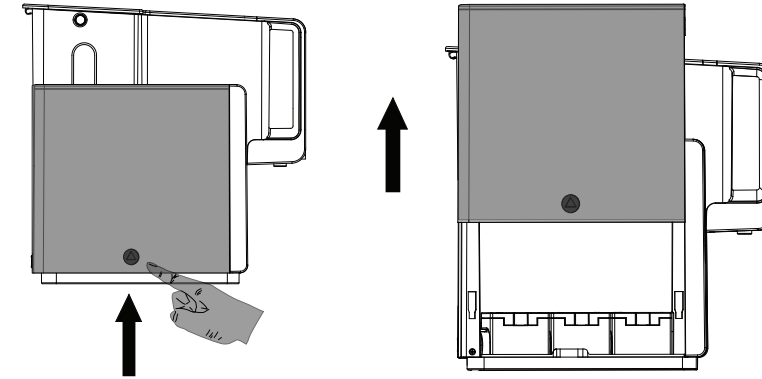

- 4 Remove filters from vacuum sealed bag.
- 5 Insert three filters into each filter bases by turning the filter in a clockwise direction. When installing filters be sure to insert them into the correct base by matching the label numbers and colors. **Please note:** the filter base pivots outward to make removing and reinstalling filters more accessible.

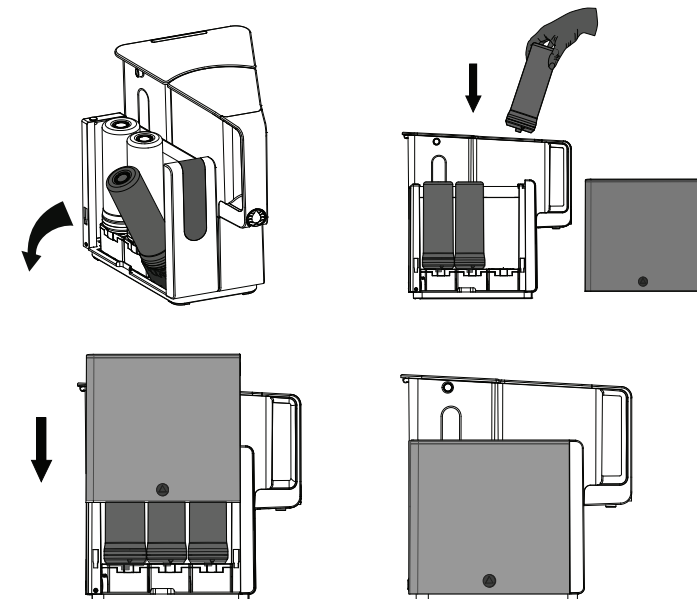



## INSTALLATION

**WARNING: Use only on municipally treated water or other supply known to be microbiologically safe.**

- 6 Plug in unit. Connect only to a circuit that is protected by a ground-fault circuit-interrupter (GFCI).
- 7 Power on the AquaTru™ using the switch located on the back.
- 8 Fill tap water tank with cold tap water and then reinstall. Be sure that both tanks are properly seated. This can be done by pressing down on tanks once in place.

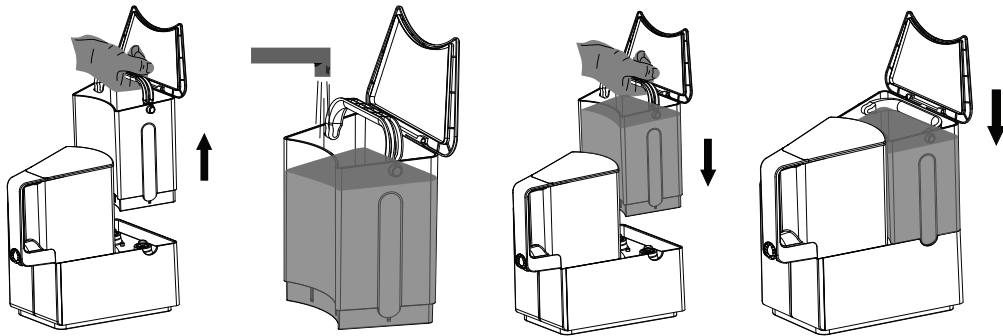

### First Time Start Up Procedure

**Run 4 full unfiltered water tanks through the AquaTru™ before drinking**

- 9 Once the tanks have been installed on the unit, it will begin to filter water automatically.

*Note: It will take longer than normal for the first tank to go through a cycle. On the first cycle a white cloud will be visible in the tap water tank. This is perfectly normal, the white cloud is tiny air bubbles released by the RO membrane.*

- 10 AquaTru™ will stop filtering water when the cycle is complete or when it is time to refill the tap water tank.

*Note: When it is time to refill the unfiltered water tank it will be quarter full.*

**All RO water filtrations systems will waste water when “back washing” the RO membrane. Most traditional RO systems have this dirty little secret. They waste up to 5 gallons of water to make 1 gallon of pure water. With our new patent pending AquaTru™ recirculation RO system, it only takes 1 gallon of tap water to make 3/4 gallon of pure water. The water left in the tap tank contains all the impurities from the tap water. This water in the tap water tank should be discarded every time you refill the tap water tank.**

- 11 Empty and rinse both water tanks.
- 12 Repeat steps 8-12, 3 more times.
- 13 When 4 cycles have been completed, your new water purifier is ready to be used.

## HOW TO USE

**CAUTION: ONLY USE COLD TAP WATER**

**WARNING: Use only on municipally treated water or other supply known to be microbiologically safe.**

- 1 Fill the unfiltered water tank with cold tap water and install on the AquaTru™ base.
- 2 Let AquaTru™ cycle until the front display turns off and your front filtered water tank is full.
- 3 When it is time to refill the unfiltered water tank, the display will illuminate the top circle. (Figure 1) Remove tank and **discard the remaining water**. Refill the unfiltered tank with cold tap water until it reaches just below the tank handle. Reinstall tank.
- 4 When clean water tank is full, press blue button to dispense water.

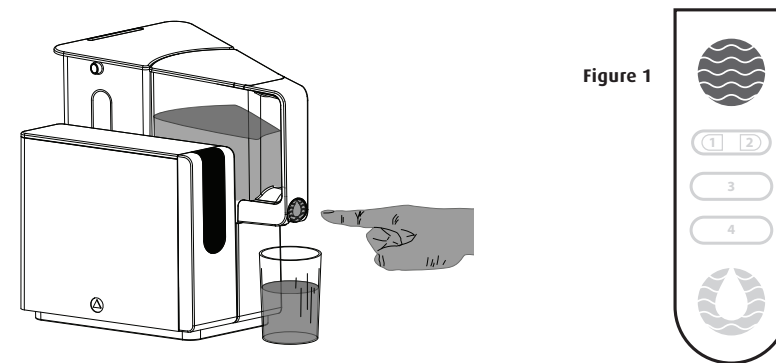
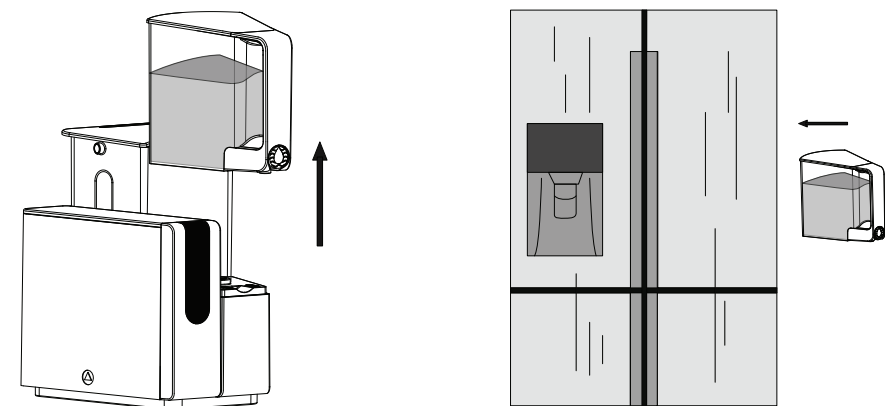

Figure 1



- 5 You can also remove water tank and place it in the refrigerator to make cold water.

Visit our website to order extra water tanks to continually purify and refrigerate water.

## CLEANING & MAINTENANCE

### Cleaning

**Tanks** – Clean both water tanks every week with soap and water. When cleaning, be sure to release soapy water from spout and tank valves on the bottom of each tank. This can be done by pressing the dispense button and spring loaded white pin at bottom of tank.

**Unit/Base** – Clean the outside of the unit using a non-abrasive sponge or towel with soap and water. To avoid water spots use clean drying towel to thoroughly dry all surfaces of the AquaTru™.

**Filters** – Clean filters by running one tank of purified water through the unit each week. This will flush out any remaining contaminants that have been collected by the filters. First, use AquaTru™ to create one full tank of clean water. Next, empty and rinse rear tap water tank. Lastly, pour clean water into tap water tank and reinstall both tanks.

*Please note: During normal use small amounts of water can occasionally leak from valves. Use a dry towel to soak up any spillage before reinstalling tanks.*

### Filter Replacement

AquaTru™ will track the usage of your filters and let you know when it's time for them to be changed. When the time comes, the front display will notify you by illuminating the filter that needs changing.

During normal use, the lights will move from filter to filter to indicate that the water is cycling through the purifying process.

When the filter needs to be changed, the filter light will remain lit on the filter that needs to be changed. Upon replacement, press the filter reset button located on the back of the unit and the lights will resume cycling through the filter numbers.

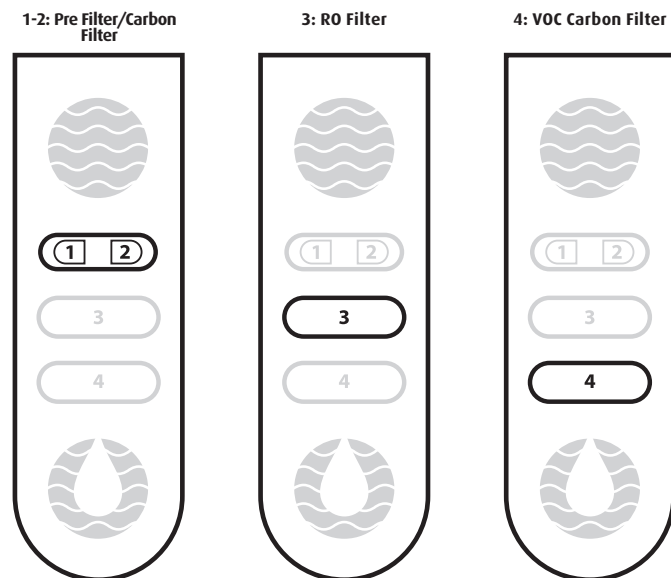

Please visit our website to purchase replacement filters / [www.aquatruwater.com](http://www.aquatruwater.com).

## CLEANING & MAINTENANCE

### Filter Replacement

**WARNING:**

**After removing the cover wait for 60 seconds before proceeding to remove the filters. After replacing a filter discard the first 2 full water tanks that AquaTru™ produces.**

- 1 Remove old filter by turning it counter clockwise. Please note: the filter base pivots outward to make removing and reinstalling filters more accessible. (Figure 1)
- 2 Install new filter by turning it clockwise. Be sure to tighten securely.
- 3 Close side panel.
- 4 Press **Filter Reset Button** located on the back of the AquaTru™ unit (Figure 2). Press and hold for at least **3 seconds**.
- 5 After installing a new filter always discard the first two full water tanks the AquaTru™ produces.

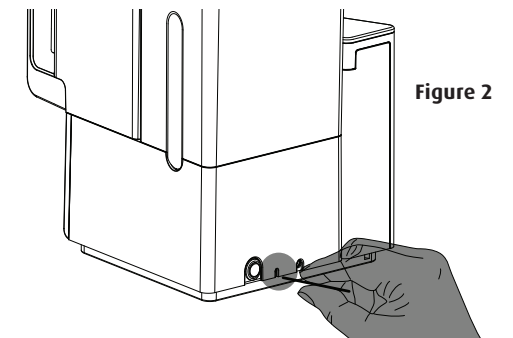
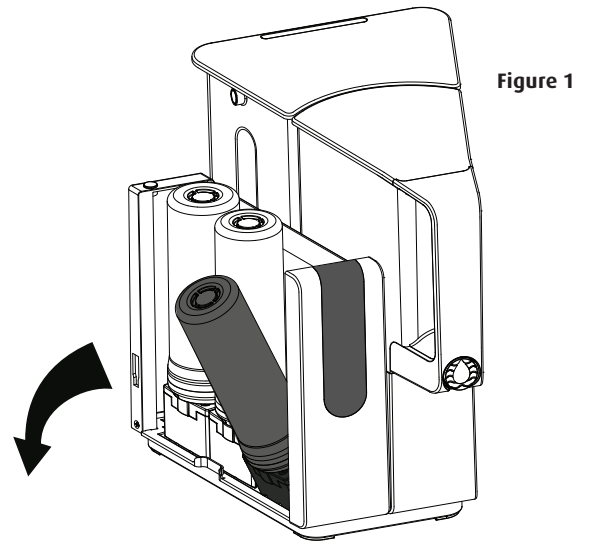

**IMPORTANT: Once you have installed the new clean filters you must press the filter reset button located on the back of the unit. If you do not do this step the filter light indicator will stay lit and the AquaTru™ will not track the life of the new filter.**

**For best results cycle 1 gallon of clean purified water through the machine once a week.**

- Filter 1-2** | Pre/Carbon Filter (Part# **AT3001**)  
**Filter 3** | Reverse Osmosis Filter (Part# **AT3002**)  
**Filter 4** | VOC Carbon Filter (Part# **AT3003**)

## TROUBLESHOOTING

PROBLEM	REASON	SOLUTION
<b>Unit will not power on</b>	Unit has not been plugged in.  Power switch is not on.	Plug power adapter into unit. Then plug power cord into power adapter. Lastly, plug power cord into CFI equipped outlet.  Turn power switch on, located on back of the unit.
<b>Clean water tank is empty but AquaTru will not start</b>	Tap water tank is empty.  Tanks are not properly seated.  AquaTru needs to be reset.	Refill tap water tank.  Reinstall both tanks.  Turn unit off and back on using power switch.
<b>The top circle is illuminated</b>	The tap water tank is empty.	Refill tap water tank.
<b>My water tank smells</b>	The water tank is dirty.  Water was left in tanks for too long.	Wash water tank with soap and water once a week.  Always empty water tanks before going on vacation.
<b>Water tank is leaking</b>	Tanks are not properly seated.  The valve may not be closing properly.  Valve may have leaked.	Reinstall tanks.  To test valve, press the small white pin with spring located at the bottom of either tank. Do this above sink as water will release from the tank.  When removing tank lift straight up. Avoid pulling up at an angle.
<b>AquaTru is filtering slower than usual</b>	The filter might have come to the end of its life.  RO filter may have become completely clogged.	Run a tank of clean purified water to flush filters.  Replace RO filter. Part# AT3002. The RO filter life is 1400 gallons. Very hard water can slow down the filtering time. Note that longer filtering times do not impact the efficiency of the filters.
<b>My clean water does not have zero TDS</b>	New VOC carbon filter has been installed.  It could be normal use or the filters may need to be changed.	Run four tap water tanks to rinse out particles from new carbon filter.  Generally, RO system lower TDS readings by 90-96% as compared to tap water readings.

## TROUBLESHOOTING

PROBLEM	REASON	SOLUTION
<b>AquaTru makes a strange noise</b>	Normal pump operation.  New filter installation.	The water pump will make noise during water filtration.  Some filters make extra noise as they become saturated. This is normal and should reduce in time.
<b>Bad tasting water</b>	New filters have not been flushed completely.  Filter may need to be replaced.  The water tanks are dirty.	Run four tap water tanks to rinse out particles from new filter.  Order new filters at AquaTru.com.  Wash water tanks with soap and water once a week.
<b>Water dispenser is leaking</b>	Small residual water may leak from the front spout.	Avoid by holding water receptacle for an extra moment when dispensing water. This will allow you to catch the remaining water.
<b>Leaking water from unit</b>	Filters installed incorrectly.  Defective filter.	Reinstall each filter ensuring that each has been properly tightened.  Check filter heads. Compare each filter to make sure that all outside O-rings are identical in size. Filters should fit tightly when installed. If loose, the filter is defective.
<b>Filter light is on and won't turn off</b>	Filter needs to be replaced.	Replace the filter that is illuminated then press the filter reset button on the back of the unit.
<b>White cloud in tap water tank</b>	Micro air bubbles from RO filter.	This is normal and may be experienced during every use.



## ONE-YEAR LIMITED WARRANTY

### ONE YEAR LIMITED WARRANTY

Your AquaTru™ water purifier is warranted to be free from defects in materials and workmanship for one year from the original purchase date. Should the product have a defect in materials or workmanship, we will repair or replace it without charge to you (a shipping and processing fee will apply). **Warranty does not include filters.** To obtain service under warranty, simply call our customer service center toll-free at **800.220.6570**.

This warranty does not cover filters, damage caused by accident, misuse or any use other than as intended and described in this product manual, or damage resulting from failure to maintain and clean this product as specified in this product manual. This warranty applies only to the original purchaser of the AquaTru™ water purifier.

**ALL EXPRESS AND IMPLIED WARRANTIES FOR THIS PRODUCT, INCLUDING IMPLIED WARRANTIES OF MERCHANTABILITY AND FITNESS FOR A PARTICULAR PURPOSE, ARE LIMITED IN DURATION TO THE WARRANTY PERIOD, AND NO WARRANTIES, WHETHER EXPRESS OR IMPLIED, WILL APPLY AFTER THIS PERIOD.**

Some states do not allow limitations on the duration of implied warranties, so the above limitation may not apply to you. While this warranty gives you specific legal rights, you may also have other rights which may vary from state to state.

### Contact Info for Warranty Service:

AquaTru™ LLC

1392 Sarah Place, Ste. B | Ontario, CA | 91761  
1.800.220.6570 | [www.aquatruwater.com](http://www.aquatruwater.com)

© 2016 AquaTru™ LLC. All Rights Reserved.



## ARBITRATION AGREEMENT

**PLEASE READ THIS AGREEMENT CAREFULLY. YOU ACCEPT THE TERMS OF THIS AGREEMENT BY RETAINING THE PRODUCT(S) SHIPPED IN CONNECTION WITH THIS AGREEMENT (THE "PRODUCTS") FOR MORE THAN THIRTY (30) DAYS AFTER RECEIPT. IF YOU DO NOT AGREE TO THE TERMS OF THIS AGREEMENT, YOU MAY RETURN THE PRODUCT TO COMPANY WITHIN THIRTY (30) DAYS OF RECEIPT FOR A FULL REFUND.**

**THIS ARBITRATION AGREEMENT ("AGREEMENT") AFFECTS YOUR LEGAL RIGHTS AND REMEDIES BY PROVIDING THAT DISPUTES BETWEEN YOU AND THE MANUFACTURER, DISTRIBUTOR AND/OR SELLER OF THIS PRODUCT (COLLECTIVELY, "COMPANY"), MUST BE RESOLVED THROUGH BINDING ARBITRATION AND NOT IN COURT. IT ALSO PROVIDES THAT ANY DISPUTE CANNOT BE RESOLVED IN A CLASS ACTION OR OTHER PROCEEDING WHERE YOU REPRESENT OTHER PERSONS OR OTHER PERSONS REPRESENT YOU, AND THAT NO CLASS OR REPRESENTATIVE ARBITRATIONS ARE PERMITTED. PLEASE CAREFULLY READ ALL TERMS IN THIS AGREEMENT.**

### 1. RESOLUTION OF CLAIMS OR DISPUTES.

Any claim or dispute between you and Company (or any of Company's subsidiaries or affiliates) arising out of or relating in any way to the Product or this Agreement shall be resolved through final, binding arbitration. This arbitration obligation is reciprocally binding on both you and the Company and applies regardless of whether the claim or dispute involves a tort, fraud, misrepresentation, product liability, negligence, violation of a statute, or any other legal theory. Both you and Company specifically acknowledge and agree that you waive your right to bring a lawsuit based on such claims or disputes and to have such lawsuit resolved by a judge or jury.

### 2. LIMITATION OF LEGAL REMEDIES.

All arbitrations under this Agreement shall be conducted on an individual (and not a class-wide) basis, and an arbitrator shall have no authority to award class-wide relief. You acknowledge and agree that this Agreement specifically prohibits you and the Company from commencing arbitration proceedings as a representative of others or joining in any arbitration proceedings brought by any other person. The parties agree that no class or representative actions of any type are permitted.

### 3. ARBITRATION PROCEDURES.

- Before instituting an arbitration, if you have any dispute, we strongly encourage you to contact the Company to try to resolve the matter by calling 800.218.3560, although you are not required to do so.
- The arbitration of any claim or dispute under this Agreement shall be conducted in accordance with the expedited procedures set forth in the JAMS Comprehensive Arbitration Rules and Procedures as those Rules exist on the date you receive the Product, including Rules 16.1 and 16.2 of those Rules. These rules and procedures are available by calling JAMS or by visiting its web site at [www.jamsadr.com](http://www.jamsadr.com). The arbitration of any claim or dispute under this Agreement shall be conducted by an arbitrator who has at least five years of experience conducting arbitrations.
- The arbitration of any claim or dispute under this Agreement shall be conducted in the State of California or the location in which you received this Agreement. For claims of \$10,000 or less, you may choose whether the arbitration proceeds in person, by telephone, or based only on submissions.
- The Company shall pay costs for the arbitration of claims, including any JAMS Case Management Fee and all professional fees for the arbitrator's services. The Company shall pay the fees and costs of its own counsel, experts and witnesses and shall not be able to recoup them from you even if you do not prevail in the arbitration. Unless otherwise provided by law, you acknowledge and agree that you shall pay the fees and costs of your own counsel, experts and witnesses.

### 4. CHOICE OF LAW.

The arbitration provisions of this Agreement and any arbitration conducted pursuant to the terms of this Agreement shall be governed by the Federal Arbitration Act (9 U.S.C. Secs. 1-16). In this respect, the parties acknowledge that this Agreement involves a transaction conducted in interstate commerce. Otherwise, this Agreement and the rights of the parties hereunder shall be governed by and construed in accordance with the laws of the State of California, exclusive of conflict or choice of law rules.

### 5. SEVERABILITY.

If any provision of this Agreement is declared or found to be unlawful, unenforceable or void, such provision will be ineffective only to the extent that it is found unlawful, unenforceable or void, and the remainder of the provision and all other provisions shall remain fully enforceable.

