



Assembly Manual

Rev 3.10

Welcome to the Family.

We're excited that you purchased the Quantum Max CNC Router Kit from BobsCNC, and we know you're just as excited to put it together. This manual gives you step by step instructions to ensure your success in assembling the Quantum Max CNC Router and provides all the information you need to get your machine up and running.

Before beginning the assembly, take all the time you need to completely review the manual. It's good to be familiar with the entire assembly process before diving in. Be sure to check out the recommended tools you'll need for the assembly.

Welcome to the BobsCNC family. It's time to... *Unleash Your Creativity!*

Contents

- Information/Warning Boxes..... 5
- Safety Precautions and Warnings 6
- Getting Started..... 7
 - Required Tools to Assemble the Quantum CNC Kit: 7
 - To Operate the BobsCNC Quantum CNC Router, you need will need: 7
 - Recommended for the electronic setup include: 7
- Assembly Recommendations: 8
- Belt Drive 9
 - Wood Components (Included with Kit)..... 9
 - Required Hardware 9
 - Illustrated Step by Step Instructions 10
- Quantum MAX X-Frame Assembly..... 16
 - Required Wood Components 16
 - Required Hardware 18
 - Illustrated Step by Step Instructions 18
- Z Spindle Mount Assembly: 56
 - Required Wood Components 56
 - Required Hardware 57
 - Illustrated Step by Step Instructions 58
- Y Carriage Assembly and Z Assembly 69
 - Required Wood Components 69
 - Required Hardware 70
 - Illustrated Step by Step Instructions 72
- Gantry Assembly..... 90
 - Required Wood Components 90

Required Hardware	91
Illustrated Step by Step Instructions	92
Final Assembly.....	122
Required Wood Components	122
Required Hardware	122
Illustrated Step by Step Instructions	124
Wire Harness.....	159
Wood Components	159
Required Hardware	159
Illustrated Step by Step Instructions	159
T-Slot Spoilboard	163
Wood Components	163
Required Hardware	163
Illustrated Step by Step Instructions	163
Completed Views	168
Tramming.....	170
Clamping System	172
Wood Components (Included with Kit).....	172
Required Hardware	172
Congratulations! You Just Completed the Assembly of Your BobsCNC Quantum CNC Router.....	173
Appendix	174
Firmware Values.....	174
Quantum Washer Size Table	175

BobsCNC Quantum Specifications

Feature list

The assembled footprint:

Length: 63" (1600 mm)

Width: 40" (1016 mm)

Height: 22" (560 mm)

Assembled Weight: 50 lbs.

Cutting Area:

X: 50.5" (1283 mm)

Y: 24" (610 mm)

Z: 3.8" (98 mm)

Safety is always the First Priority. Always wear proper protective equipment and use "safety sense" when assembling and operating your Quantum Series CNC Router.

Information/Warning Boxes

	<p>CAUTION Indicates a possible risk of injury that can result from failure to follow this instruction</p>
	<p>WARNING Indicates the possible damage to the machine, its components, the work piece, or injury that can result from failure to follow this warning.</p>
	<p>DANGER Indicates a serious risk of bodily harm, injury and death. This is a serious warning and should not be ignored. Any work must be carried out with extreme caution.</p>
	<p>TIPs Contains helpful information, shortcuts, and hints to simplify assembly and make machine operation easier and safer.</p>

Safety Precautions and Warnings

BobsCNC Routers have a 110 v. Power Supply and use bits that spin at 30,000 rpm with cutting edges that are sharp and hazardous. The operator must understand the potential hazards and is responsible to take appropriate safety precautions before operating the Router.

- Only use extension cords rated for 20 amps plugged into a dedicated outlet.
- Inspect the machine before every use for maintenance issues: loose fasteners, belts, etc.
- Do not operate the machine with dull or damaged router bits.
- Always unplug machine after each use and when cleaning the router or changing router bits.
- Remove rings, bracelets, watches, necklaces before using the machine.
- Wear snug fitting clothing and/or roll up long sleeves to prevent snagging.
- Use appropriate personal protective equipment (PPE) when operating machine including safety glasses and hearing protection.
- Keep hands, hair and clothing away from the moving parts of the machine.
- Do not operate the machine when under the influence of alcohol or prescription medications.
- Make certain the workpiece is clamped securely in place before starting the machine.
- Never leave the machine running unattended.
- Children must be supervised by adults when operating the machine.
- Do not operate the machine in the presence of flammable materials.
- Keep floors clean, dry, and free of debris to eliminate slip and/or trip hazards.
- Have a suitably rated fire extinguisher on hand when the machine is in operation.

Getting Started

Required Tools to Assemble the Quantum CNC Kit:

Metric Socket Set

#1, #2 and #3 Phillips Screw Drivers

Needle Nose Pliers

Set of Metric Allen Wrenches

Pliers

Utility Knife

Clear Nail Polish or Blue LOCTITE

Scissors

Blue Painter's Tape

To Operate the BobsCNC Quantum CNC Router, you need will need:

Computer with control software for GRBL.

Materials for Projects.

1/4 inch Shaft Router bits. A 1/8 inch Collet must be purchased to use 1/8 inch Shaft Router bits.

Recommended for the electronic setup include:

Multimeter to correctly connect the Power Supply and to set the current for the Stepper Motors (a great tool for general electronic trouble shooting).

Assembly Recommendations:

Use a large, flat, clean work surface for assembling your Quantum Max.

All Screws (unless noted) should be installed snug, then rotated 1-2 ½ turns.

Apply LOCTITE 242™ or clear fingernail polish to all M4 X 16 mm Machine Screws that are used to secure plywood pieces. Machine Screws that are secured with Lock Nuts do not need LOCTITE™.

Light sanding of the wood components may be performed if desired.

Painting or applying stain with a clear coat will provide extra protection to the wood components.

Clean the rails with acetone to remove rust preventative and apply a light coat of PTFE (Teflon®) lubricant.

We recommend using strips of 1-inch blue painter's tape behind the T-Slots to help hold the Nuts in place during assembly.

Lock Nuts are never used to secure components that have T-Slots. They are only used to mount components where the Nut is not held in a T-Slot.











CAUTION This kit contains numerous small components that pose a choking risk for small children and pets. Keep kit pieces in a secure location out of the reach of small children and pets.

Belt Drive

Wood Components (Included with Kit)

Part #	Description	Qty	Photo
QR2	XY Stepper Motor Mount	3	

Required Hardware

Part #	Description	Qty	Photo
H86	Flanged Bearing F635Z	12	
H48	M5 x 30 Machine Screw	6	
H49	M5 Lock Nut	6	
H50	Idler Fender Washer	18	
H89	Small Black Washer	12	
H84	GT2 Pulleys	3	
H37	M3 x 10 Machine Screw	12	
H88	M3 Washer	12	

CB11	Stepper Motor	3	
------	---------------	---	--

Illustrated Step by Step Instructions

Step 1 Preparing the Stepper Motors for Mounting

- Step 1a** Align one of the Set Screws of the GT2 Pulley (H84) to the flat surface of the Stepper Motor Shaft. Snug the Set Screw so that it engages the shaft but still allows the Drive Pulley to slide down the shaft.

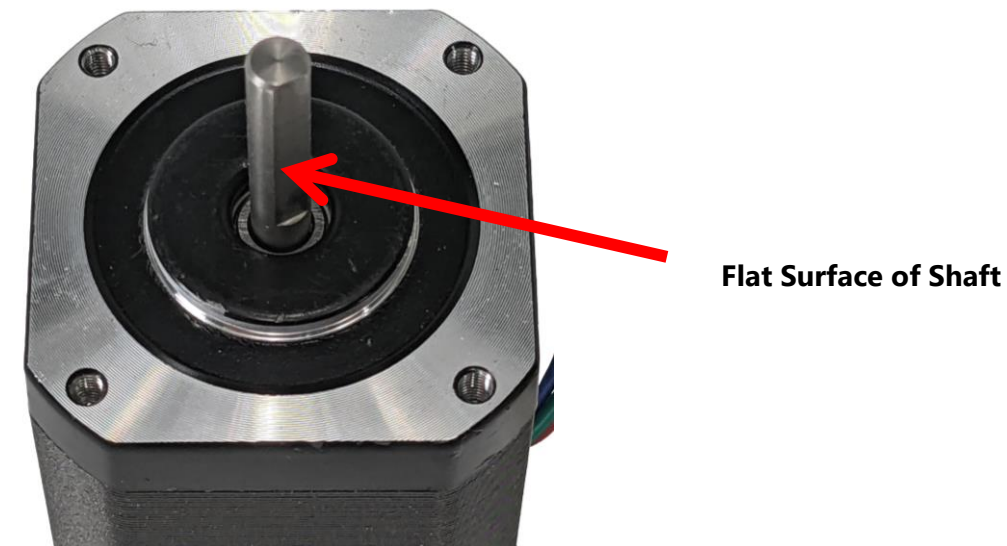

Step 1b

Use an Idler Fender Washer (H50) as a shim and gently slide the Drive Pulley down to the surface of the Washer.



Fully tighten the Set Screw against the flat. Tighten the second Set Screw. Remove the Idler Fender Washer. The gap between the bottom of the GT2 Pulley and the Stepper Motor

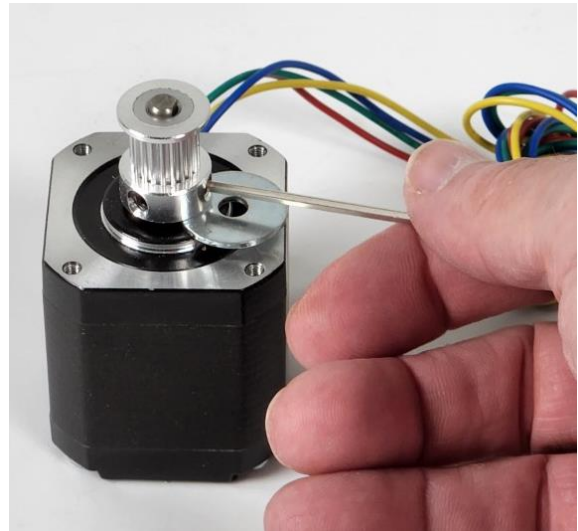

housing will be approx. 1.25mm. Repeat for two more Stepper Motors for a total of three.

Step 2 Mounting the Stepper Motors

Step 2a Build six Idler Bearing Assemblies using one M5 x 30 Machine Screw (H48), two Flanged Bearings (H86), two Small Black Washers (H89) and two Idler Fender Washers (H50) in the sequence shown below.



Be sure the head of the Machine Screw fits against the Bearing flange and the other is mounted so that both flanges are oriented outboard from each other.

Step 2b Insert the threaded shaft of the Bearing Assembly through the XY Stepper Motor Mount (QR2), add Idler Fender (H50) washer, and secure with a M5 Lock Nut (H49).



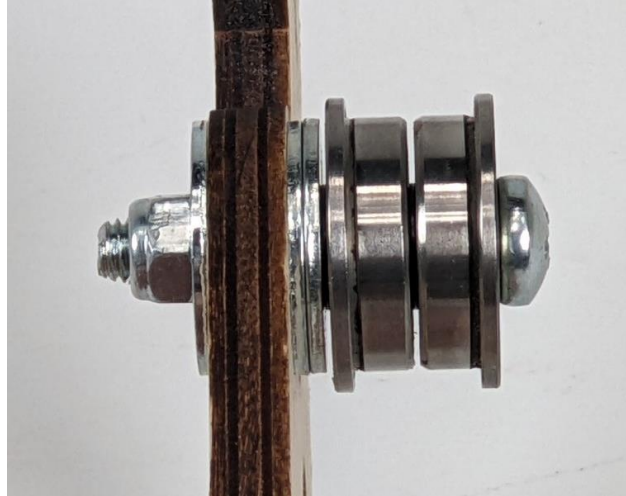

Repeat to install the remaining 2 Idler Assemblies.

Step 2c Align the mounting holes of the Stepper Motor with holes in the Stepper Motor Assemblies.

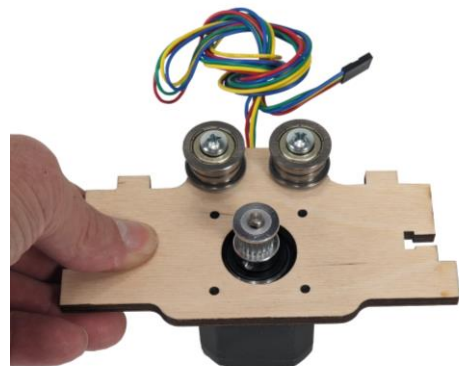
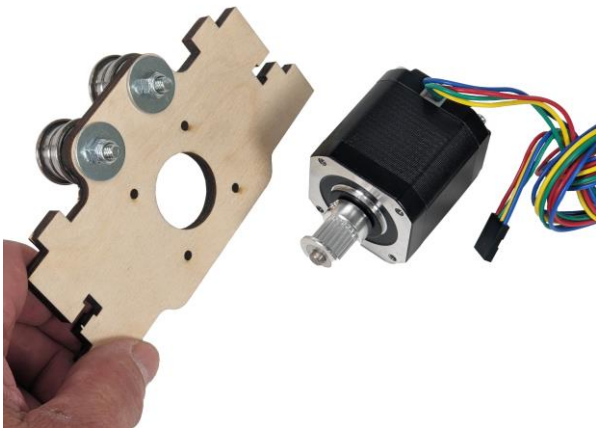

Secure the Stepper Motor to the XY Stepper Motor mount with four M3 x 10 Machine Screws (H37) with M3 Washer(H88).

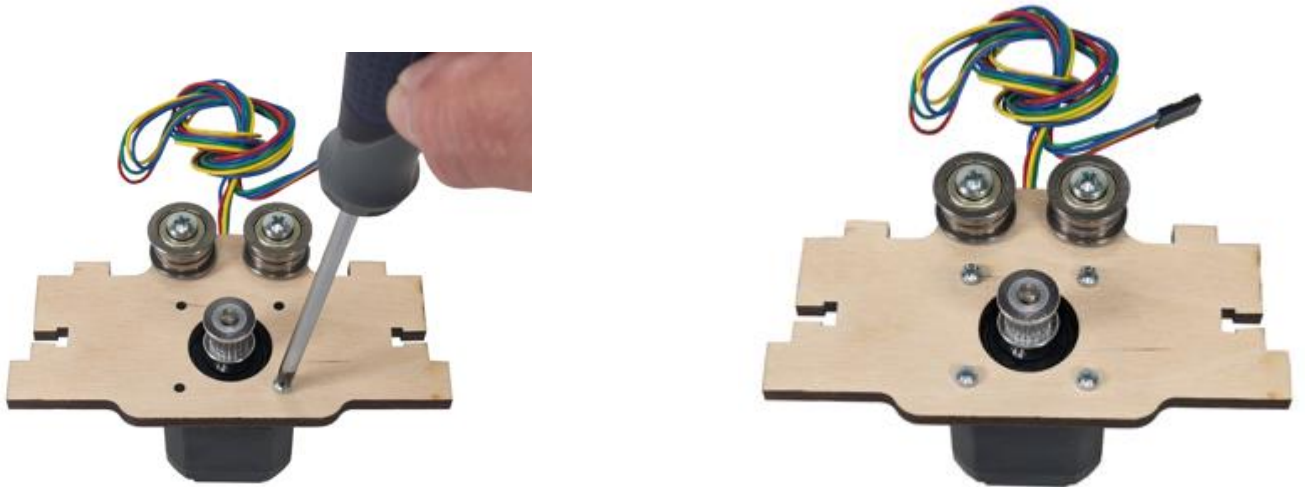

NOTE: When viewed from the back the Stepper Motor wires of each Motor are oriented in three directions. The wires of the Y Stepper Motor are centered between the Idler Bearing and run upward. The wires of the X1 and X2 Stepper Motor run one to the left, the other to the right as shown below.

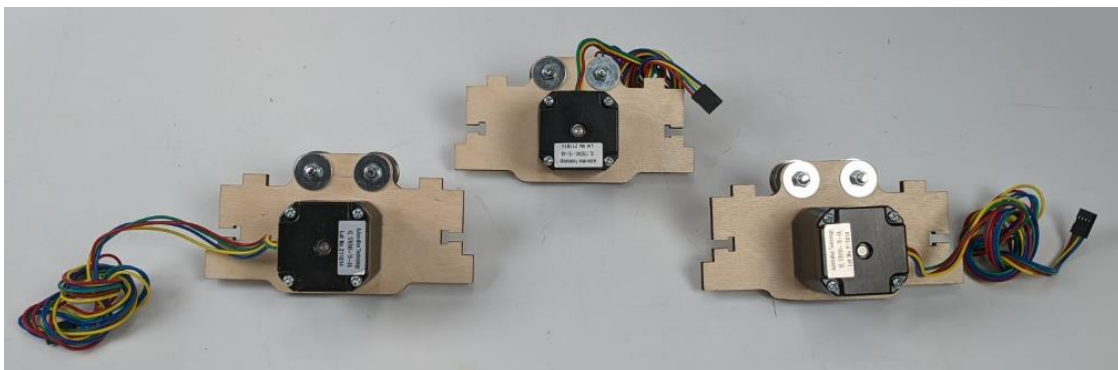

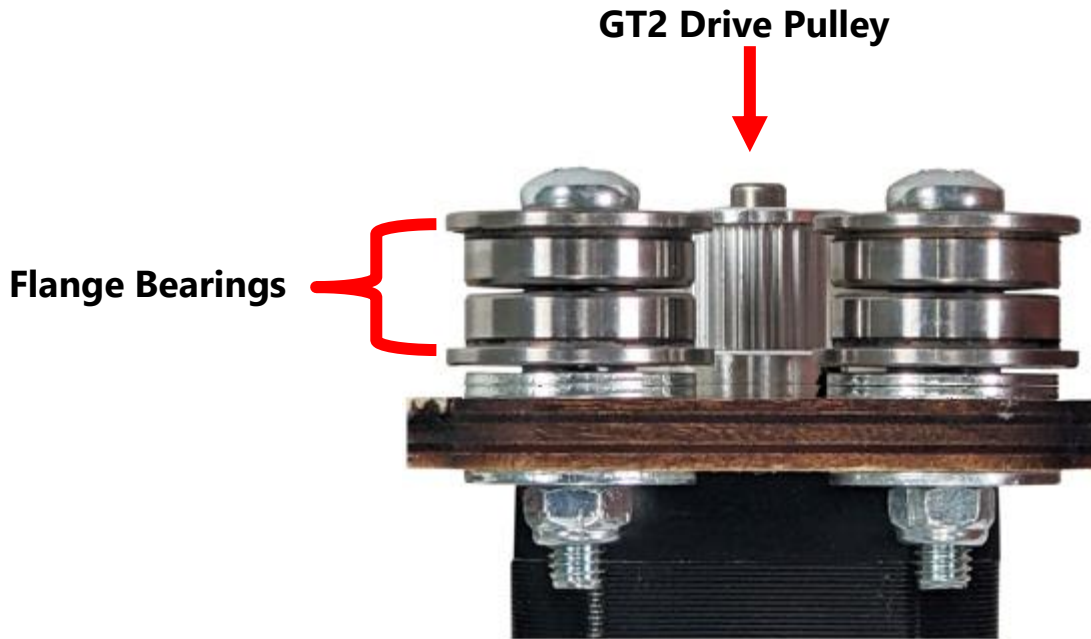

NOTE: When correctly installed, the flanges of the Idler Bearings will frame the teeth of the GT2 Drive Pulley (see below).

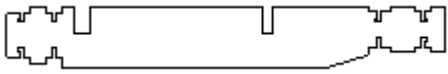

Quantum MAX X-Frame Assembly

Required Wood Components

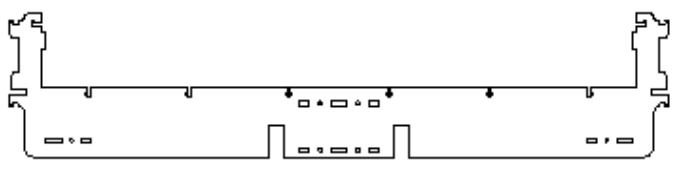
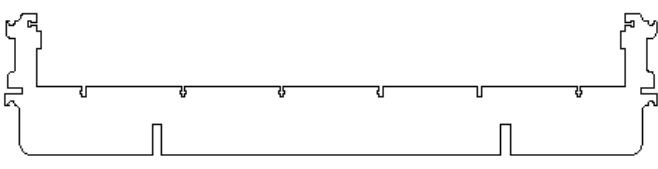
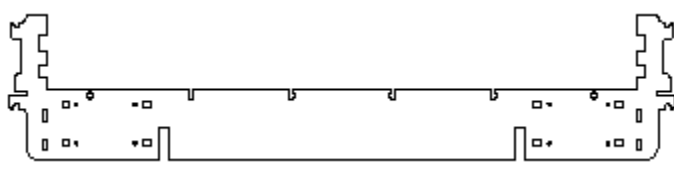
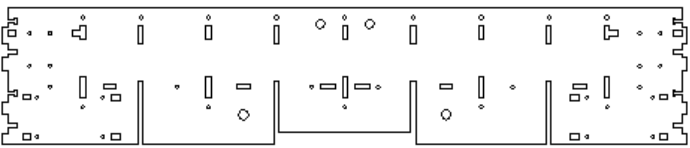
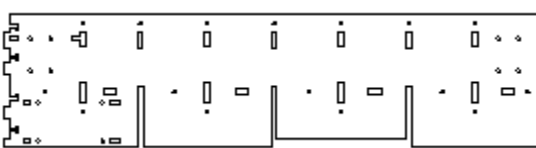
Part #	Description	Qty	Photo
QX1	Rail Support	18	
QX2	Torsion Arm	6	
EQX2	Extension Torsion Arm	2	
QX3	Inner Frame Mid Support	4	
QX4	Outer Frame Mid Support	3	
EQX4	Extension Frame Mid Support	1	
QX5	Frame Side Support	2	
EQX5	Extension Frame Side Support	2	

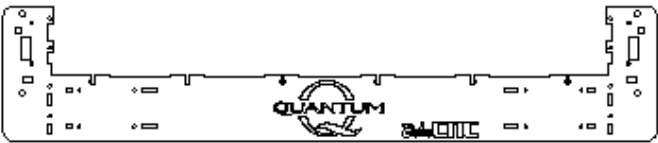
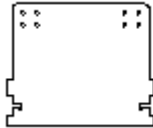
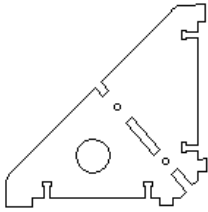
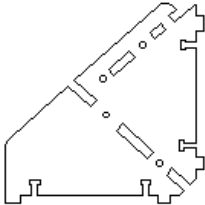
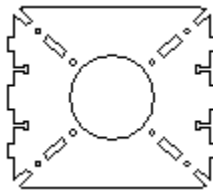
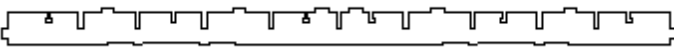
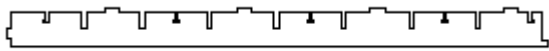
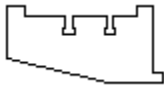
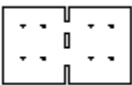
QX6	Frame End Support	2	
QX7	Wire Harness Support	4	
QX8	Frame Corner Support	8	
EQX8	Extension Frame Corner Support	4	
QX9	Torsion Plate	2	
QX10	Frame Side Brace	2	
EQX10	Extension Frame Side Brace	2	
QX11	Belt Support	2	
EQX12	Extension Coupling Plates	2	

Required Hardware

Part #	Description	Qty	Photo
H14	M4 x 16 Machine Screw	240	
H15	M4 Nut	240	
H47	M4 Lock Nuts	16	



WARNING There are two long and two short Torsion Arms in the Max Front X-Frame Assembly. The long Torsion Arms are located on the front of the Assembly. The short Torsion Arms are located at the rear of the Assembly.

Illustrated Step by Step Instructions

The Quantum Max X Frame consists of two components, the Front X Frame Assembly and the Rear X Frame Assembly. The following steps will cover building the Rear X Frame Assembly.

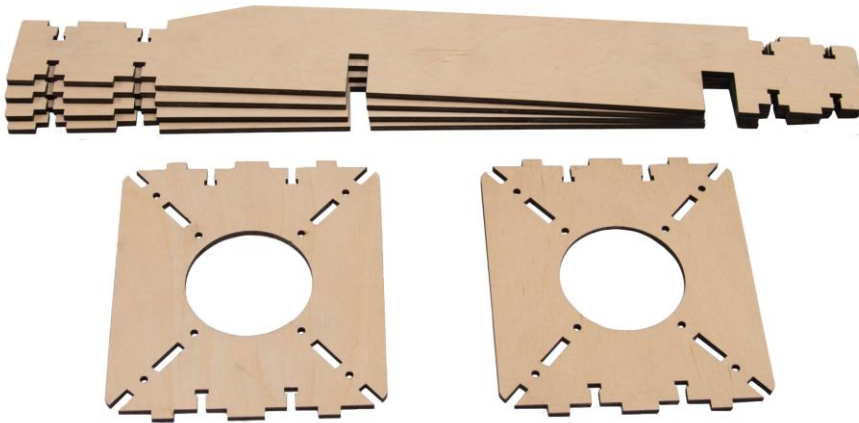

Step 1 Use strips of painter's tape to cover all the T-Slot cutouts in each of the four Torsion Arms (QX2) and Torsion Plates (QX9) as shown.

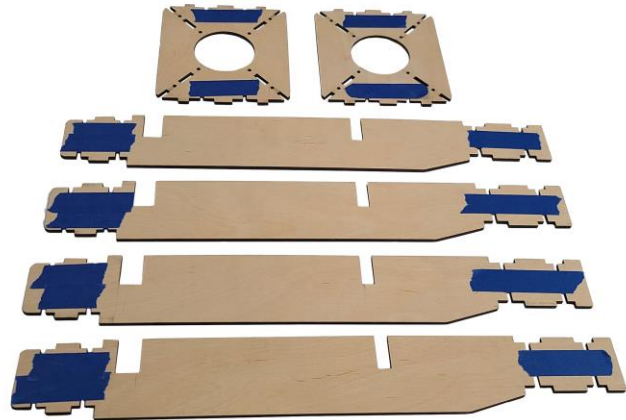
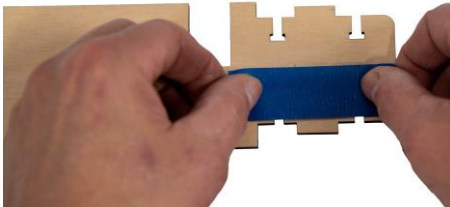

Step 2

Turn the Torsion Arms over and install a M4 Nut (H15) in each of the T-Slots as shown below.



Cover the installed M4 Nuts with strips of painter's tape.

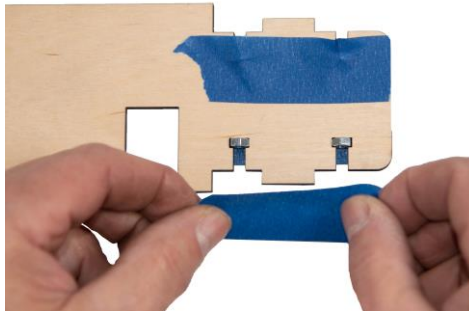

This will create a pocket to hold each of the M4 nuts in place to make it easier to connect the Torsion Arms (QX2) to the Torsion Plate (QX9).



Step 3

Align the tab of the Torsion arm (QX2) with the corresponding slot in the Torsion Plate (QX9). Notice how the rectangular notch is oriented. Make sure the cutout in each of the torsion arms is oriented in the same way in the Assembly.

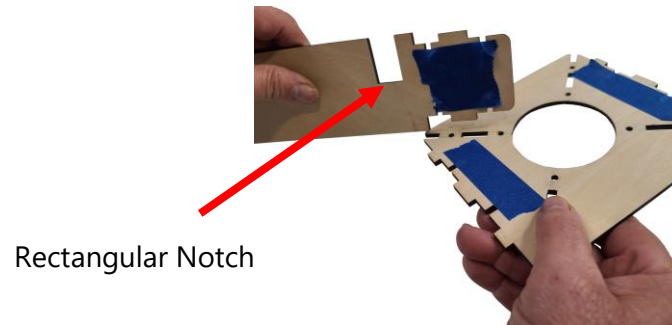

Step 4

Secure the Torsion Arm to the Torsion Plate using two M4 x 16 Machine Screws (H14) as shown below.



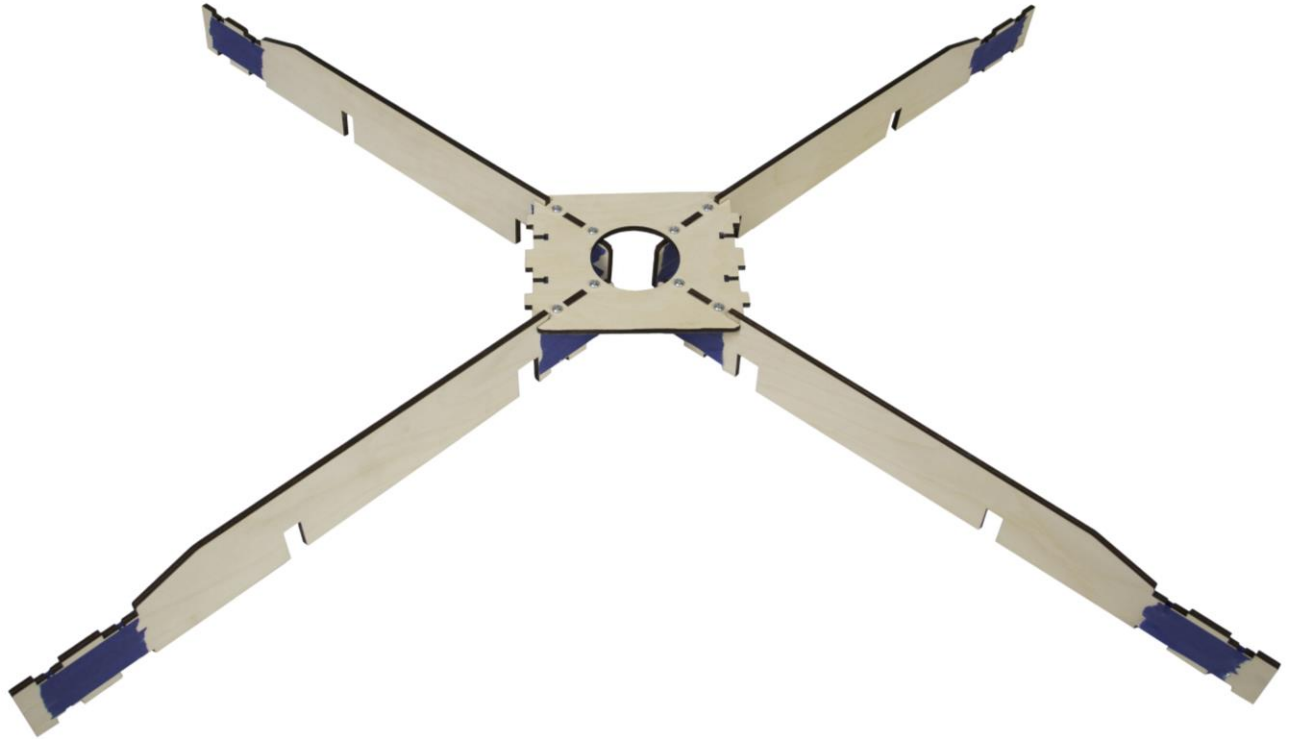

Repeat to install all four QX2 Torsion Arms.

Step 5 Carefully turn the Assembly over and align the slots in the Torsion Plate with the tabs on the Torsion Arms. Secure with eight M4 x 16 Machine Screws.

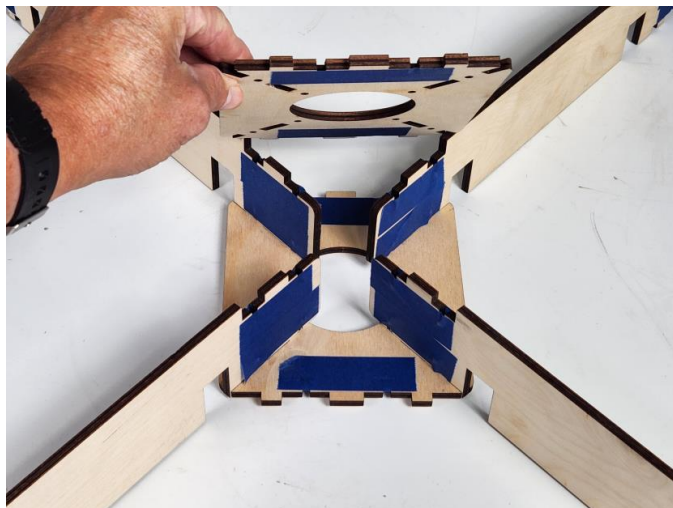

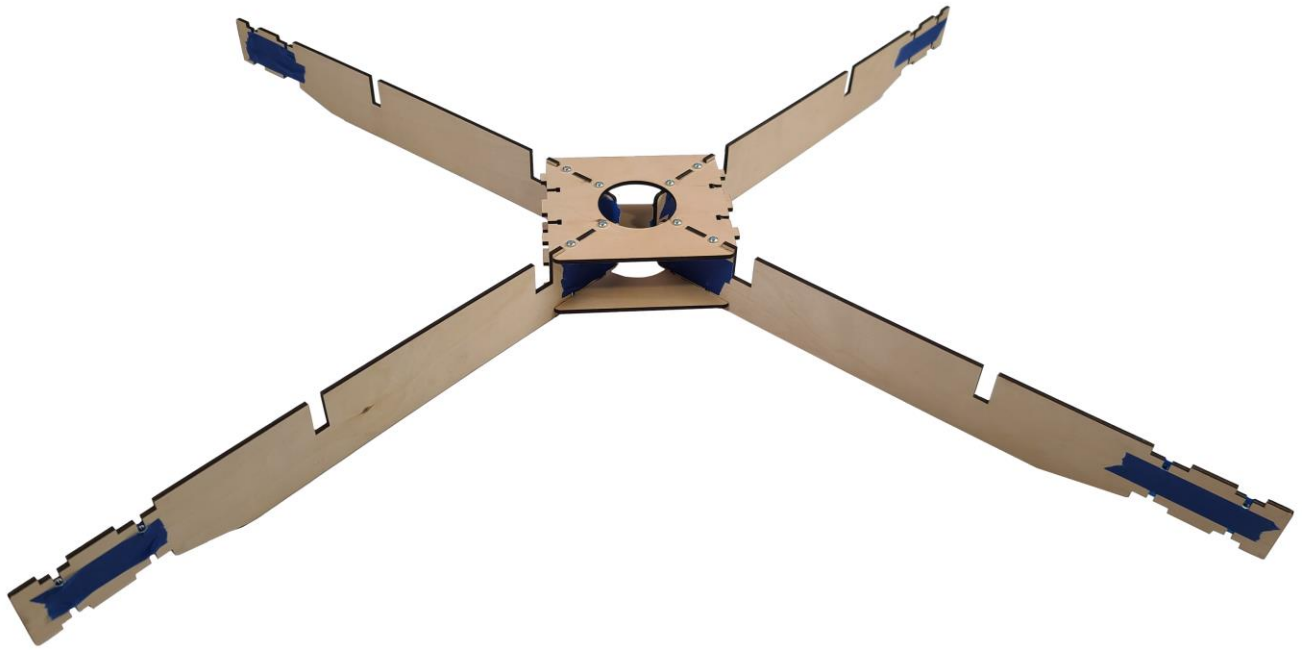

Step 6 This step will cover attaching 4 Frame Corner Supports (QX8), the two Wire Harness Supports (QX7), the two Inner Frame Mid Supports (QX3) and the two Outer Frame Mid Supports (QX4). Parts shown below.

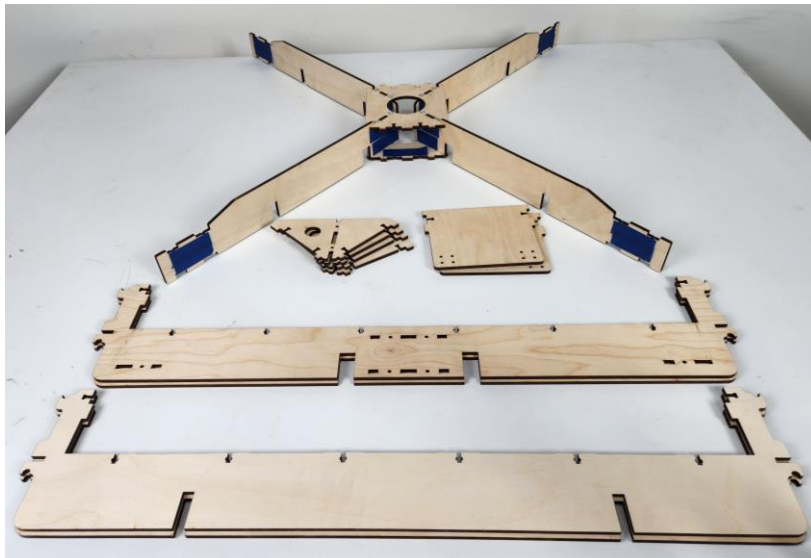

Step 6a Make sure the open T-Slots on the inner sides of the Torsion Plates are covered with strips of painter's tape, this will create pockets to hold the four M4 x16 Nuts inserted, as shown.

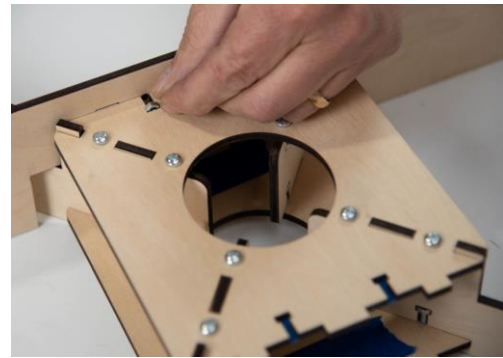
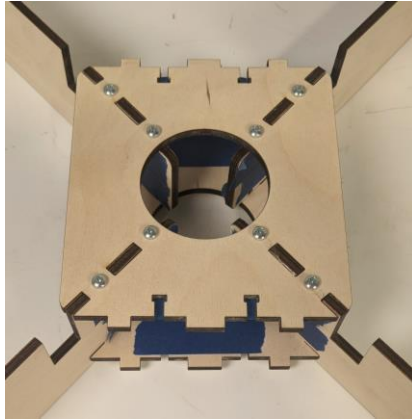

Step 6b Align the large slots of the Inner Frame Mid Supports (QX3) with those of the X-Frame Assembly. Carefully lower the Inner Frame Mid Support (QX3) into place as shown.

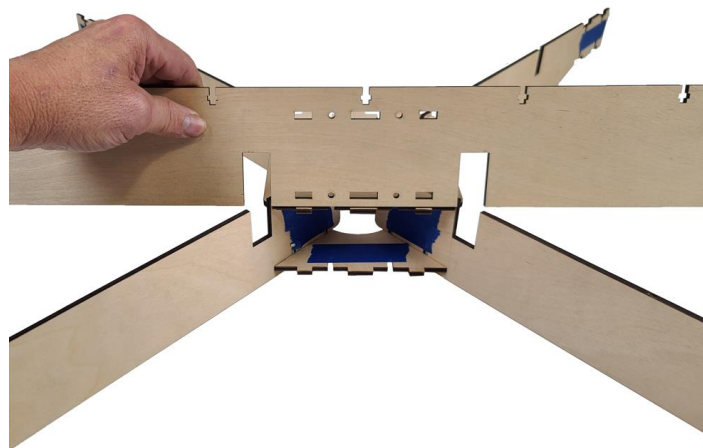

Align the slots in the Inner Mid Frame Support (QX3) with the tabs of both Torsion Plates. When the tabs are fully seated, secure with four M4 Machine Screws and Nuts in each Plate.

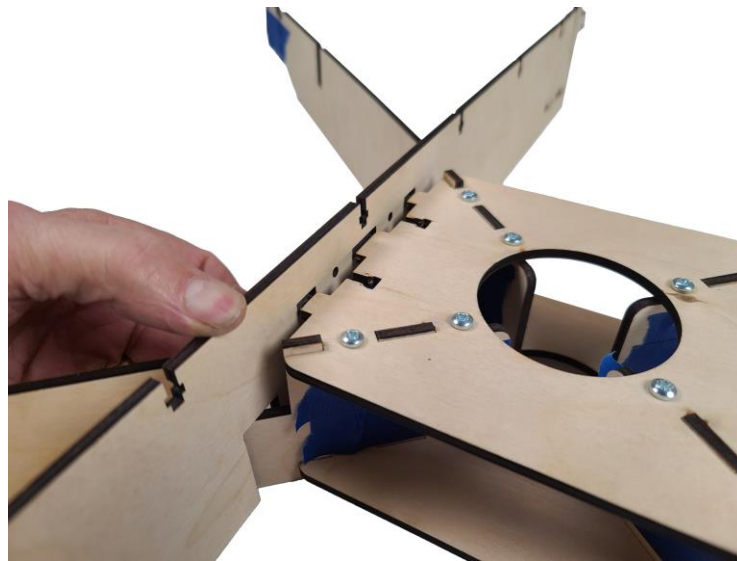

Repeat to attach the top and bottom of the second Inner Mid Frame Support.

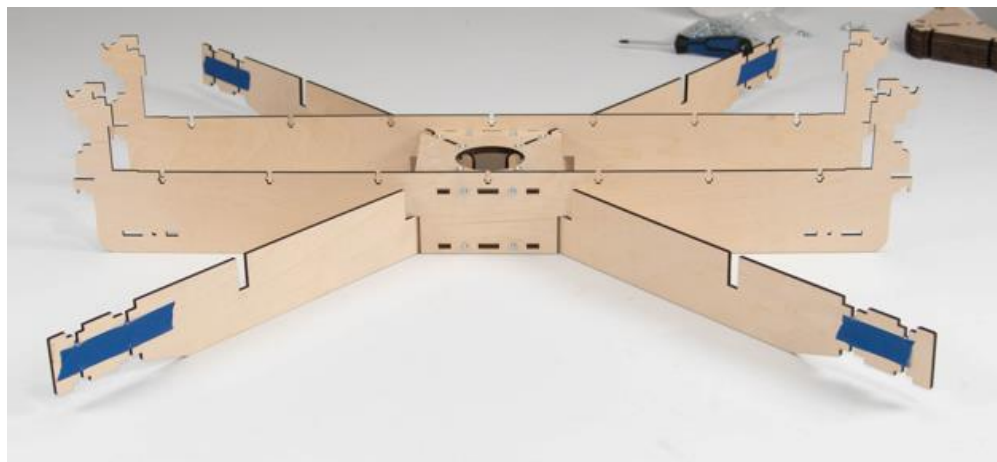

Inner Mid Frames attached to Torsion Assembly

Step 6c Insert the tabs of the Wire Harness Support (QX7) into the slots at the end of the Inner Frame Mid Supports and secure with two M4 x 16 Machine Screws and Nuts for each.

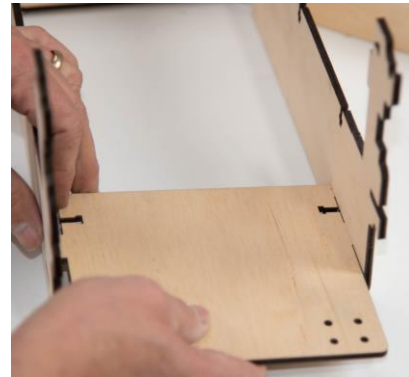

Both Wiring Harness Supports attached.

Step 6d Align the slots of the Outer Frame Mid Support (QX4) into the slots at the end of the Torsion Arm Assembly and slide into place as shown.

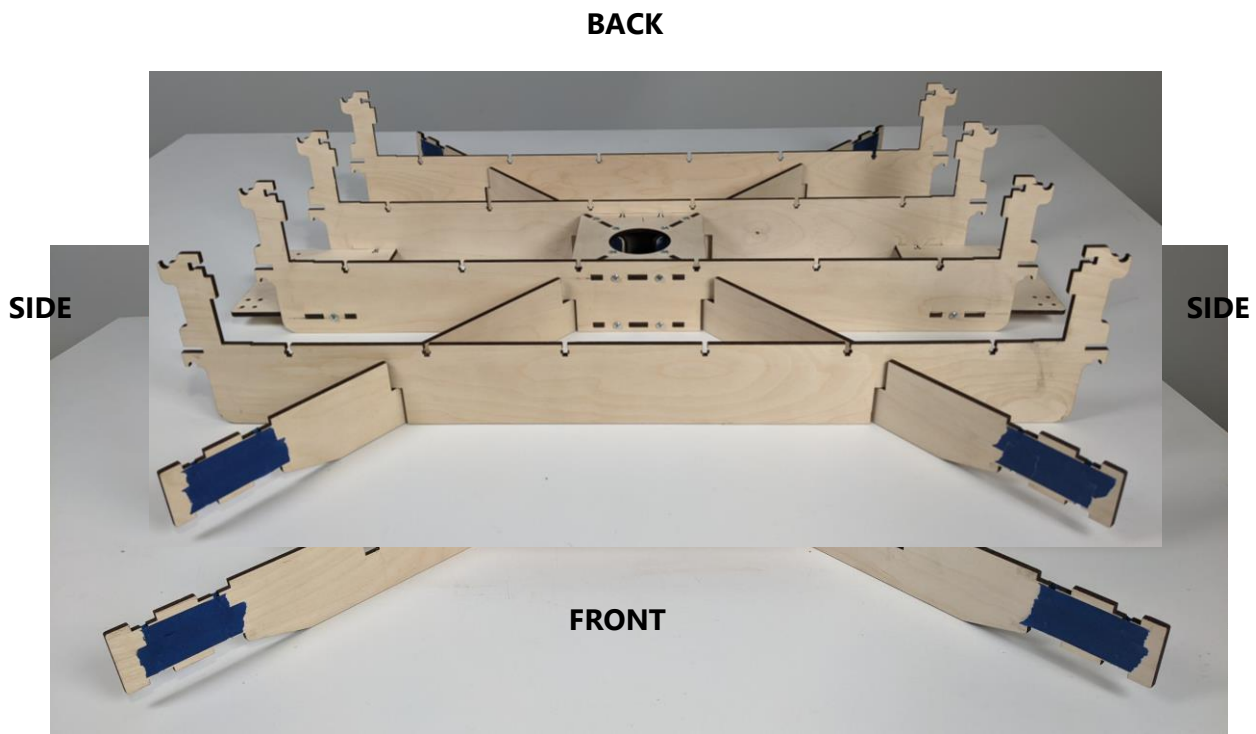

In the photo above, note the orientation of the components in the Rear X-Frame Assembly.

Step 7

Attach two Frame Corner Supports (QX8) on the Torsion Arms (QX2). Note the circular cutout in the Frame Corner Support can only be installed facing toward the front or back of the X Frame Assembly. In the Quantum Max, it is oriented to rear.

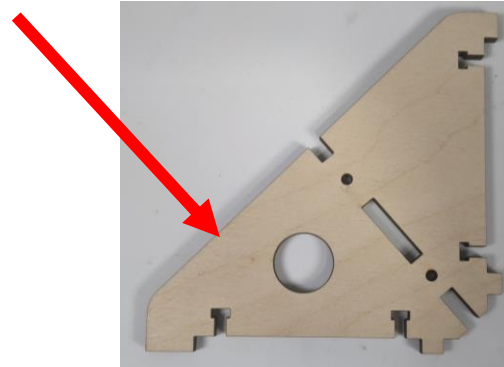

Step 7a

Align the slots in the Frame Corner Supports (QX8) with the tabs on the Torsion Arms (QX2). Slide in place and secure with two M4 x 16 Machine Screws. (The M4 Nuts were previously installed and held in place with blue painter's tape). Repeat for each of the corners.



Step 7b Turn the Assembly over and attach the two remaining Frame Corner Supports (QX8) using M4 X 16 Machine Screws

After the four Corner Supports are attached, use painter's tape to cover the T-Slots on the inside surface of the corner supports as shown.



Step 7c Turn the Assembly to complete the next step.

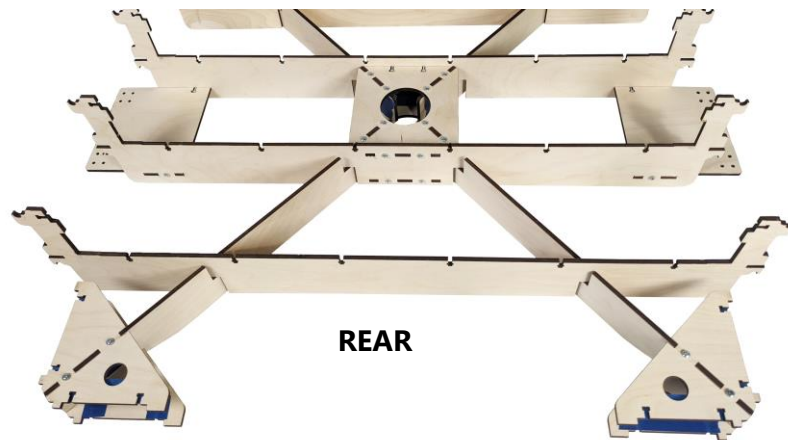



Step 8 Attaching the (QX1) Rail Supports to the (QX5) Frame Side Support.

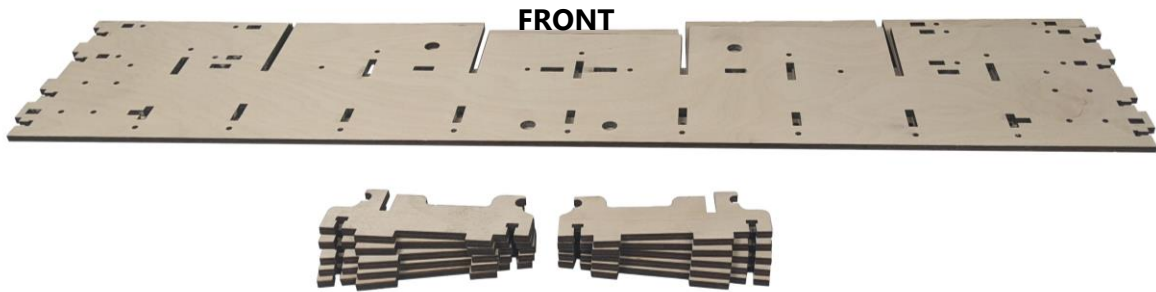

Step 8a

Insert the tabs of the ten Rail Supports (QX1) into the corresponding slots of the Frame Side Supports (QX5) as shown and secure each with two M4 x 16 Machine Screws and Nuts.

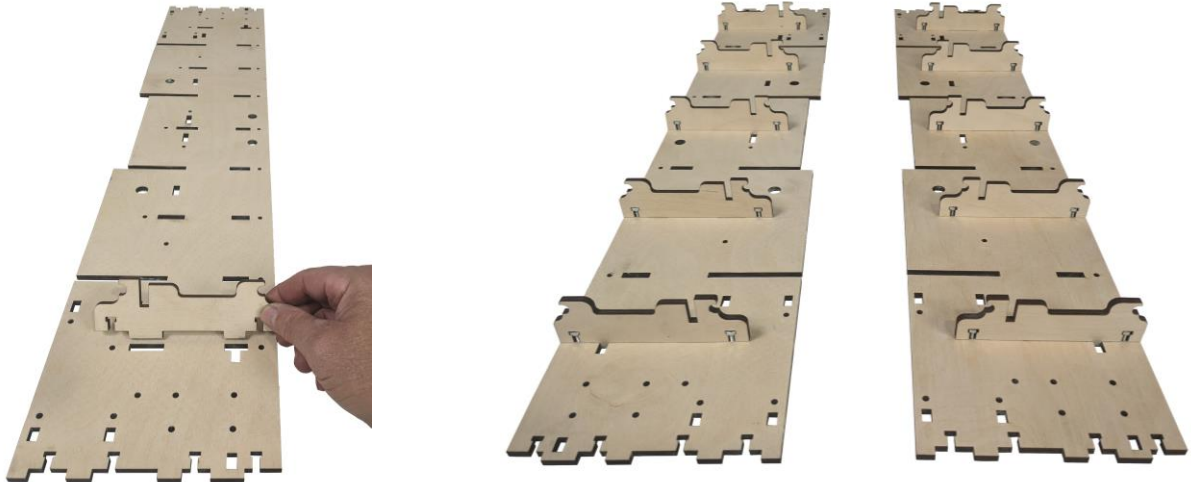

Step 8b

Align the tabs on the X Frame Assembly and the slots of the Frame Side Assembly as shown and secure with four M4 X 16 Machine Screws and Nuts.

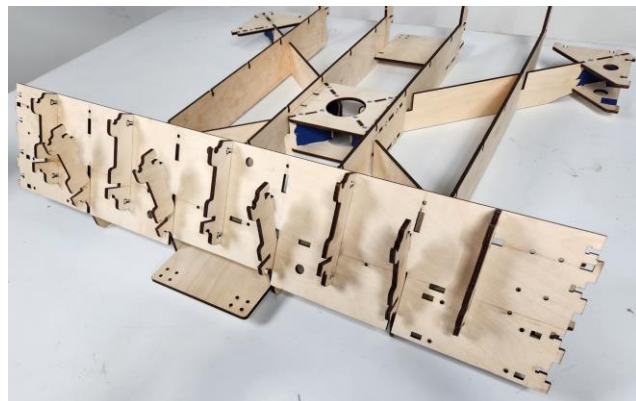
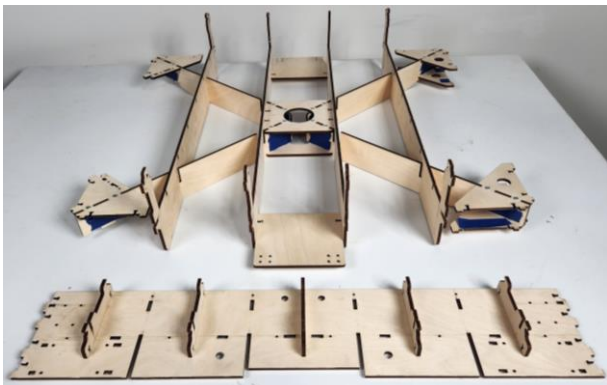

Step 9

Attach two Extension Frame Corner Supports (EQX8) on the Torsion Arms (QX2). Note the notch in the Corner Support must be oriented toward the front and the center of the Assembly.

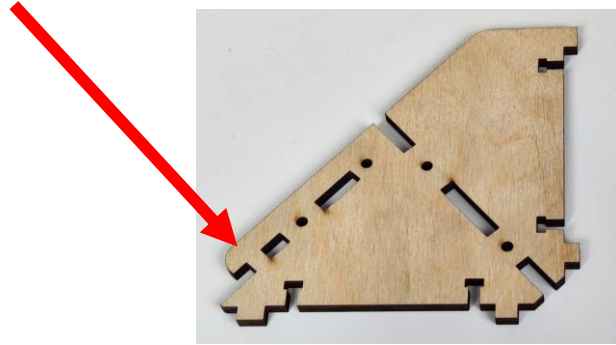

Step 9a

Align the slots in the Frame Corner Supports (QX8) with the tabs on the Torsion Arms (QX2). Slide in place and secure with four M4 x 16 Machine Screws and Nuts. Repeat for both top corners.

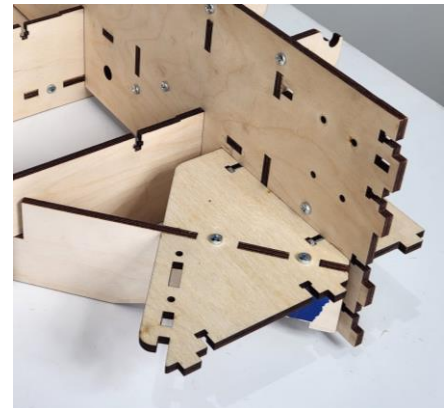
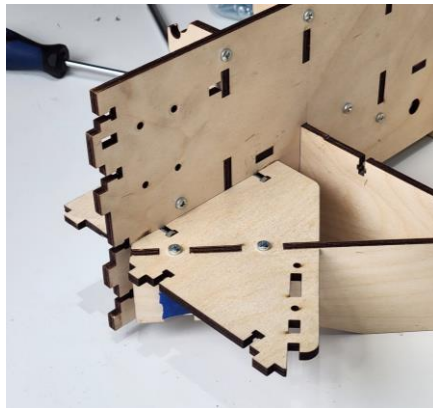

Only install the top EQX8 Extension Frame Corner Supports. The bottom Extension Frame Corner Supports will be installed in a later step.

Fit the tabs of the Fame Corner Supports (QX8) into the slots of the Side Assembly and secure with four M4 x 16 Machine Screws and Nuts. Turn the Assembly over to insert the Screws and Nuts on the Bottom Frame Corner Supports (QX8). Repeat to complete both sides.



Step 10 Attaching the Belt Supports (QX11), the Frame End Support (QX6) and the Frame Side Brace (QX10).

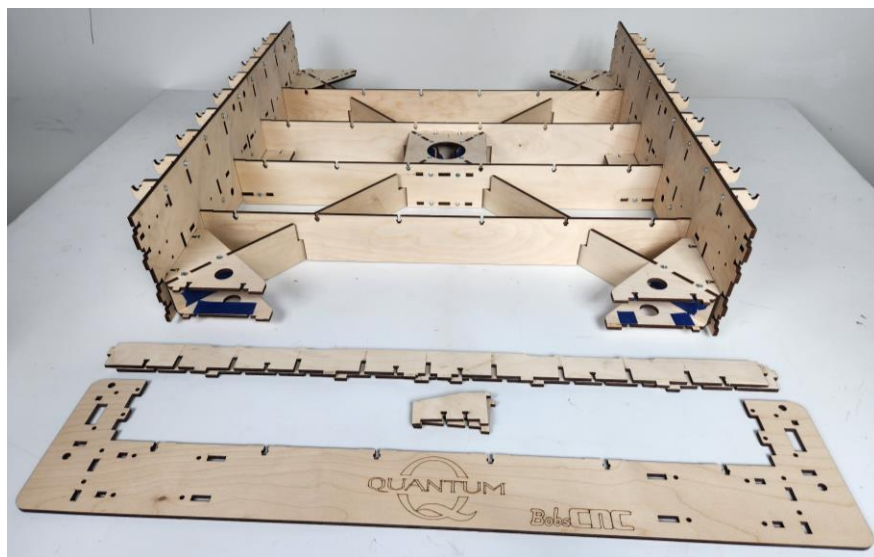

Step 10a Align the tabs of two of the Belt Supports (QX11) in slots located at Rear of the X Assembly and secure two M4 X 16 Machine Screws and Nuts for each, as shown.

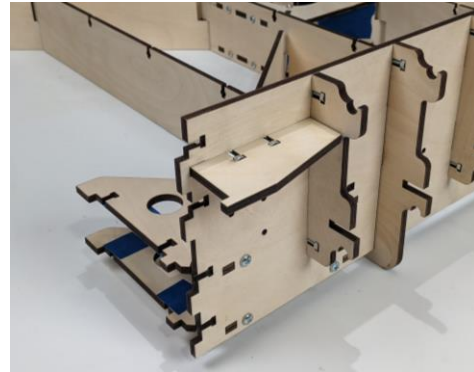
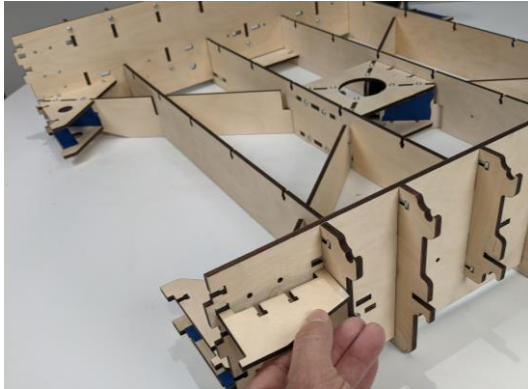

Step 10b Align the slots of the Frame Side Brace (QX10) with the slots in the Side Assembly. Insert the tabs of the Frame Side Brace (QX10) into the corresponding slots in the Side Assembly as shown below. Secure with six M4 Machine Screws and Nuts. Repeat to complete the installation the Frame Side Brace on the opposite side of the Assembly.

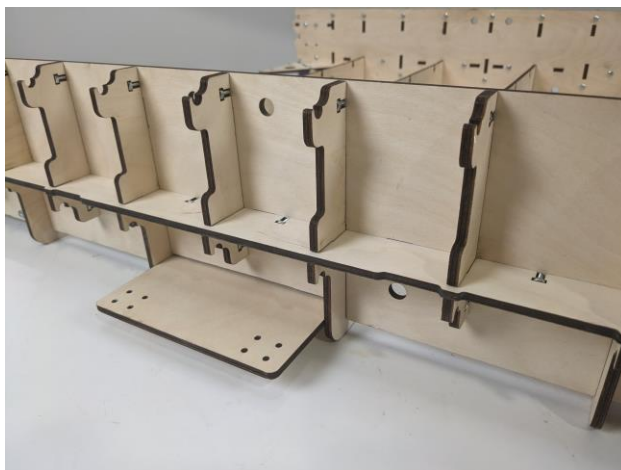

Step 10c Align the tabs and slots of the Frame End Support (QX6) with the tabs and slots of the Side Assembly and secure with eight M4 X 16 Machine Screws and Nuts for each side.

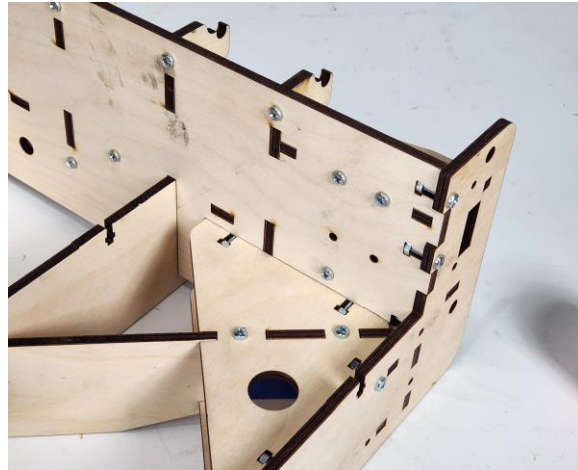

Back View

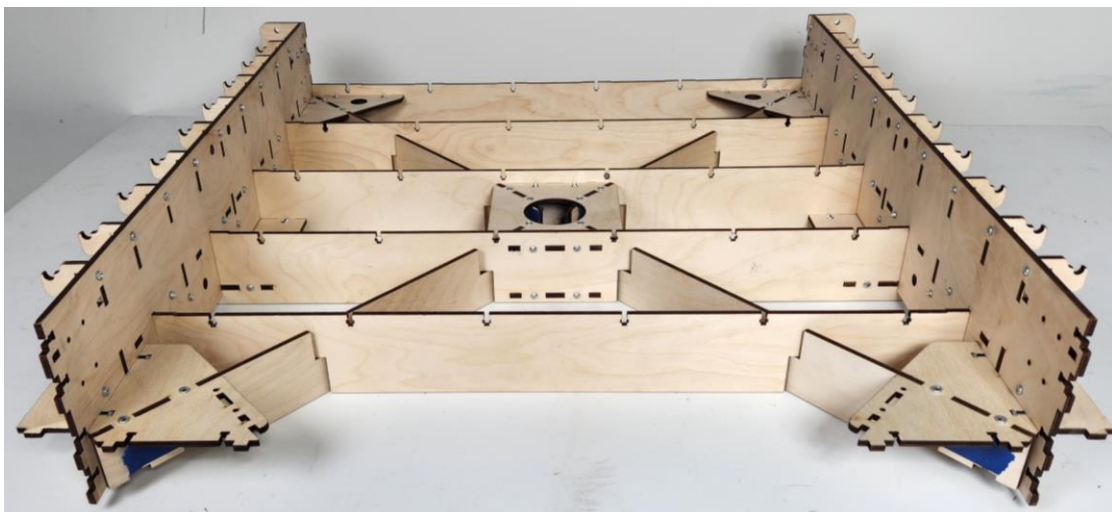

Front View

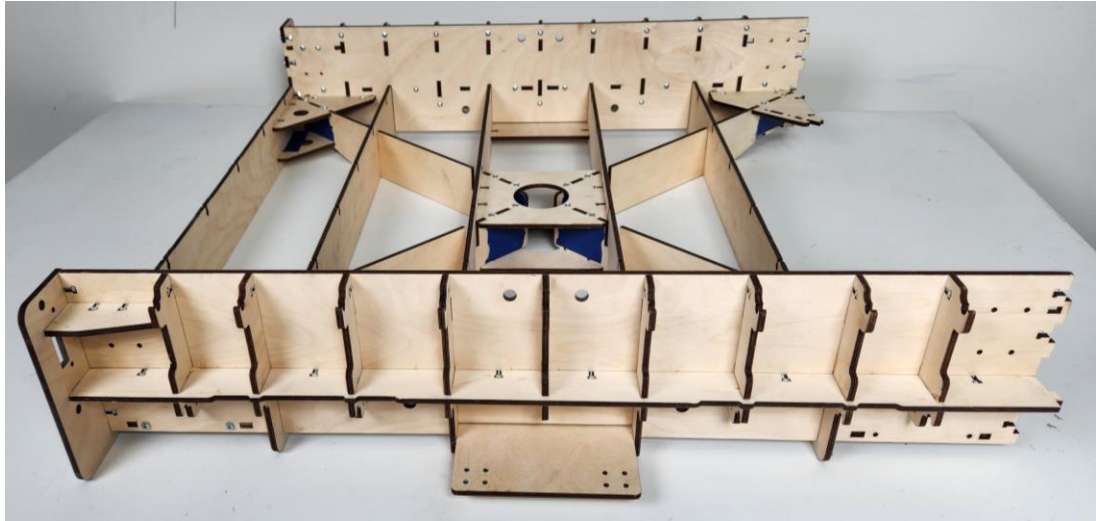

Side View

The following steps will cover building the Front X Frame Assembly.



Step 1

Use strips of painter's tape to cover all the T-Slot cutouts in each of the four Torsion Arms (QX2 and, EQX2) and Torsion Plates (QX9) as shown.

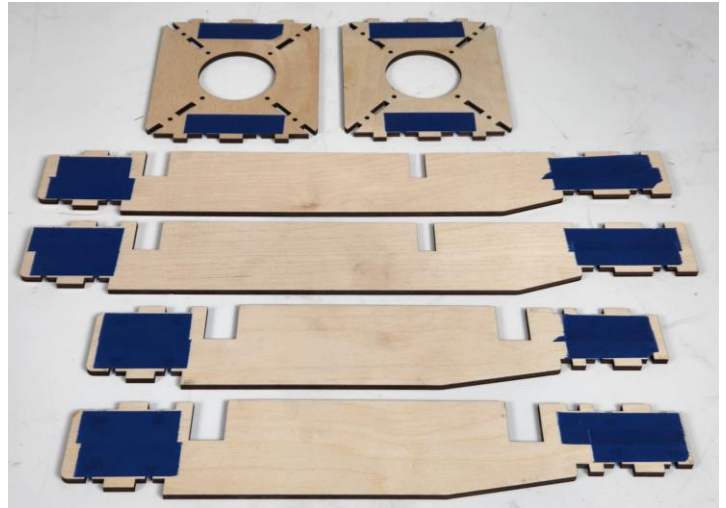
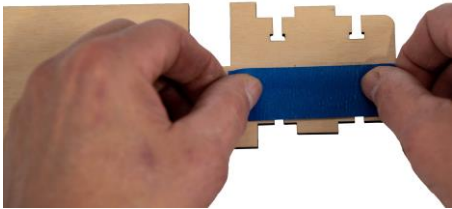

Step 2

Turn the Torsion Arms over and install a M4 Nut in each of the T-Slots as shown below.



Cover the installed M4 Nuts with strips of painter's tape.

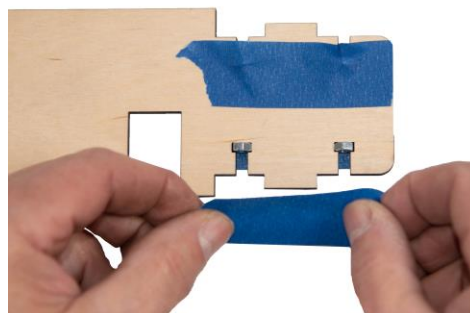

This will create pockets to hold the M4 nuts in place making it easier to connect the Torsion Arms (QX2 and EQX2) to the Torsion Plate (QX9).



Step 3

Align the tab of the Torsion arm (QX2) with the corresponding slot in the Torsion Plate (QX9). Notice how the rectangular notch is oriented. Make sure the cutout in each of the Torsion Arms is oriented in the same way in the Assembly.

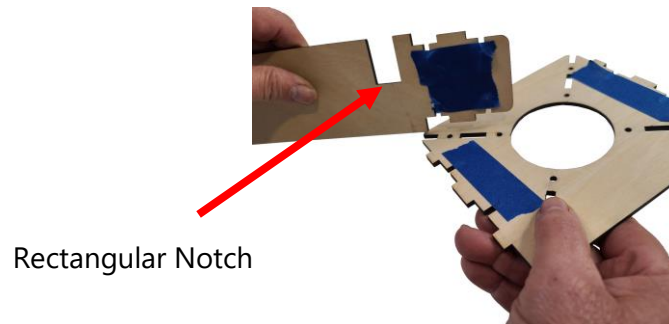

Step 4

Secure the Torsion Arm (QX2) to the Torsion Plate using two M4 x 16 Machine Screws as shown below.





Step 5 Repeat to secure the Extension Torsion Arm (EQX2) to the Torsion Plate using two M4 x 16 Machine Screws each.



Step 6 Carefully turn the Assembly over and align the slots in the Torsion Plate with the tabs on the Torsion Arms.

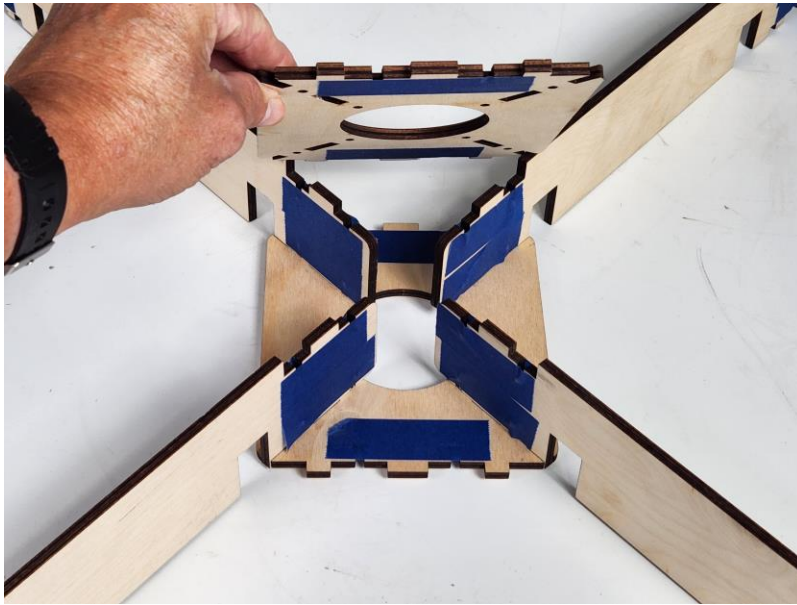

The taped side will be turned over before securing with eight M4 x 16 Machine Screws as shown below.

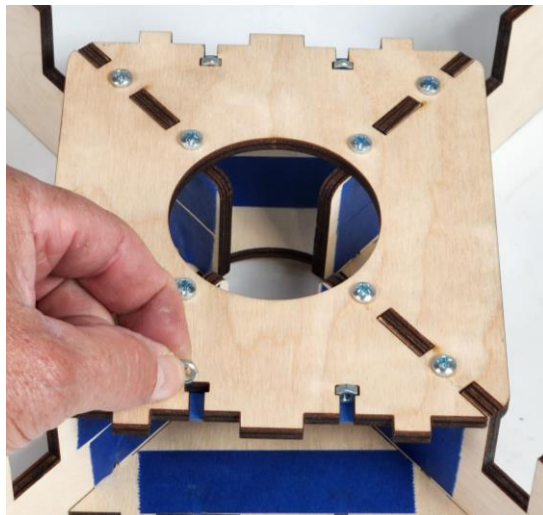

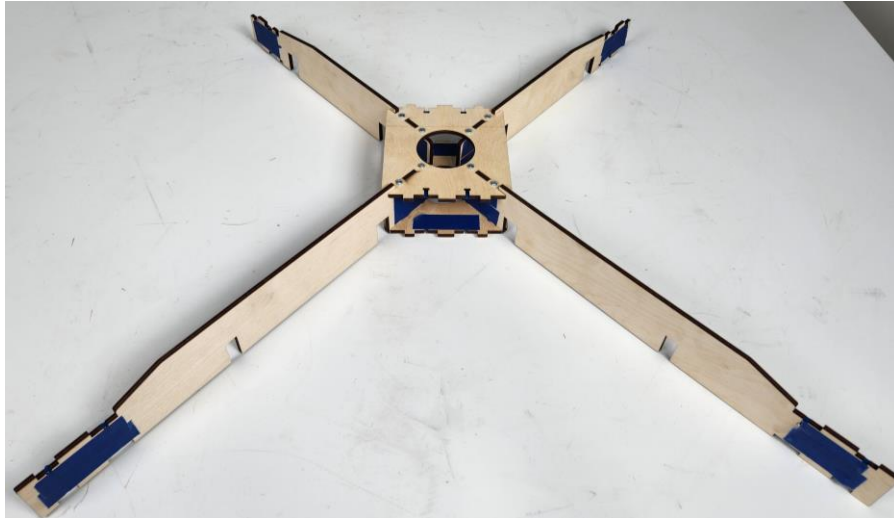

Step 7 Installing the Inner Frame Mid Supports (QX3), Outer Frame Mid Support (QX4), Wire Harness Support (QX7), Frame Corner Supports (QX8), Extension Frame Corner Supports (EQX8), and Extension Coupling Plates (EQX12).

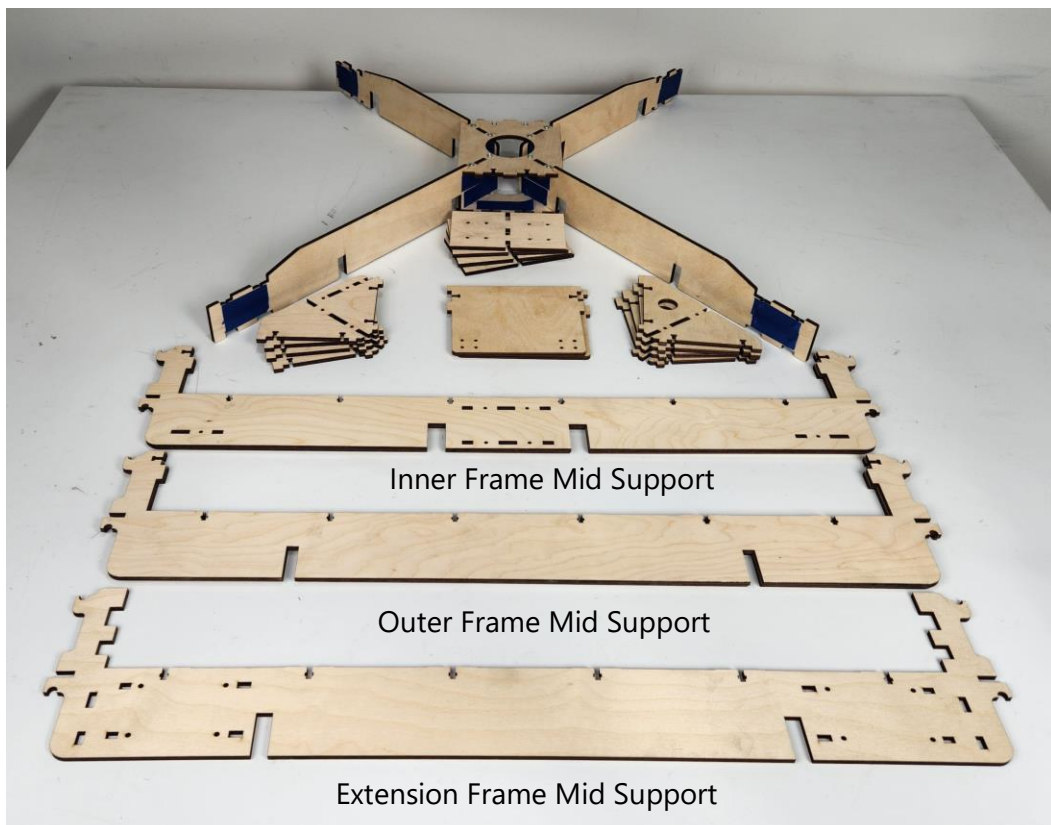

Step 7b Align the large slots of the Inner Frame Mid Supports (QX3) with those of the X-Frame Assembly. Carefully lower the Inner Frame Mid Support into place as shown.

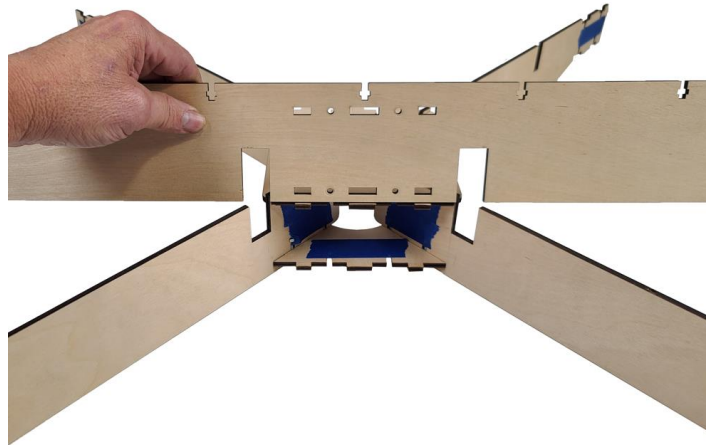

Align the slots in the Inner Frame Mid Support (QX3) with the tabs of both Torsion Plates.

When the tabs are fully seated, secure with four M4 X 16 Machine Screws and Nuts in each Plate.

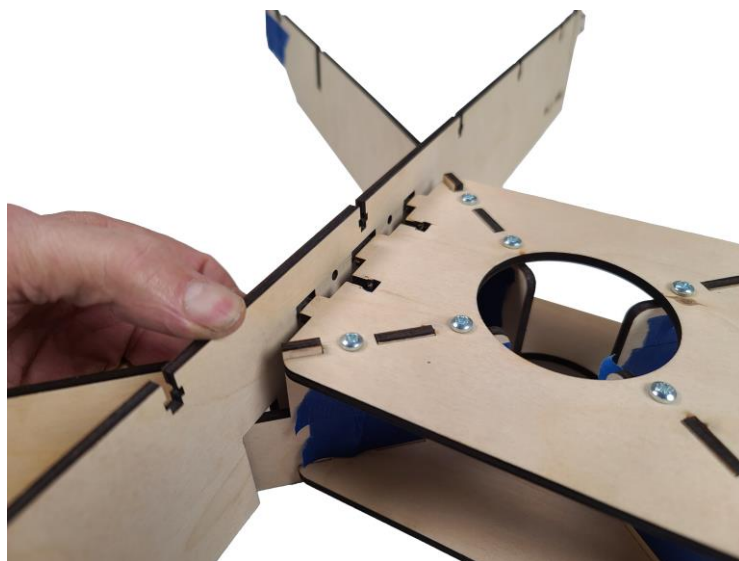

Repeat to attach the top and bottom second Inner Frame Mid Support.

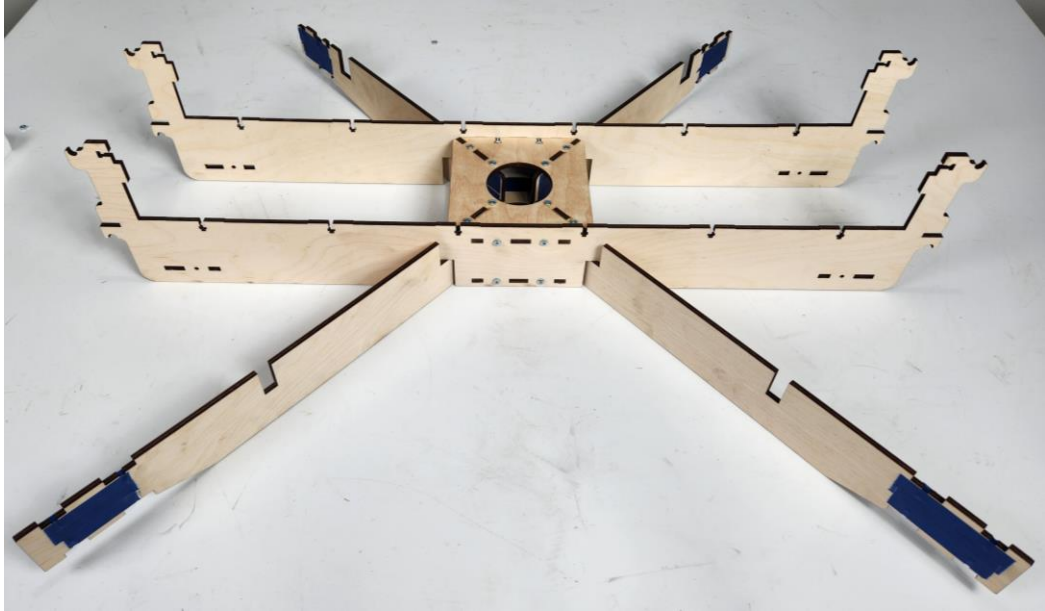

Step 7c Insert the tabs of the Wire Harness Support (QX7) into the slots at the end of the Inner Frame Mid Supports and secure with two M4 x 16 Machine Screws and Nuts for each.

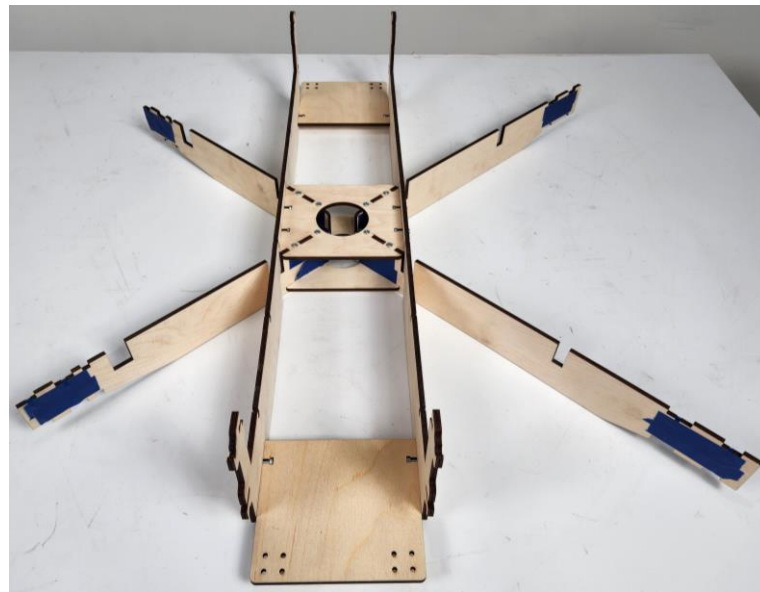
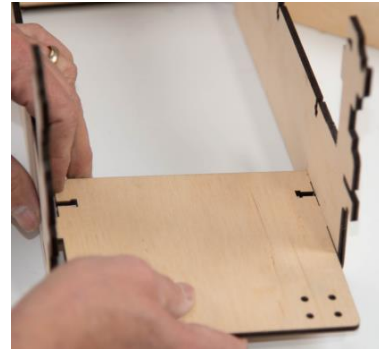

Both Wiring Harness Supports attached.

Step 7d Align the slots of the Outer Frame Mid Support (QX4) into the slots at the end of the Slots of the Torsion Arm (long) Assembly and slide into place as shown.

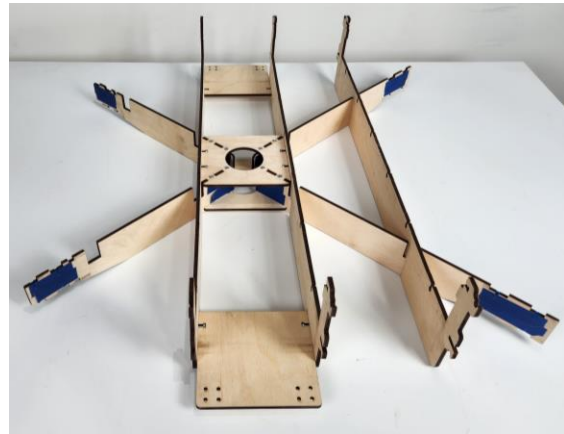
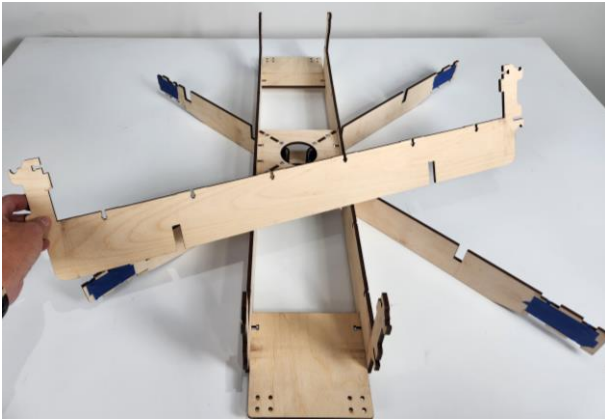

Step 7e Install four Frame Corner Supports (QX8) and secure with two M4 x 16 Machine Screws each, closest to Outer Frame Mid Support (QX4) as shown.

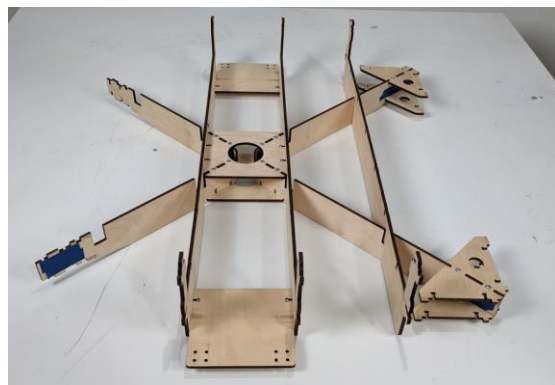
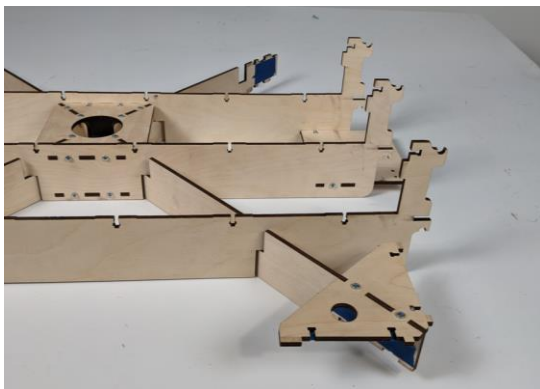

Step 7f Install blue painter's tape on both sides of the Frame Corner Support (QX8) upper and lower sides as shown.

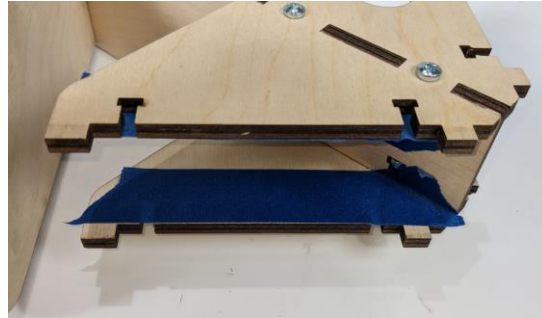

Step 8 Attaching the Front and Rear Assemblies

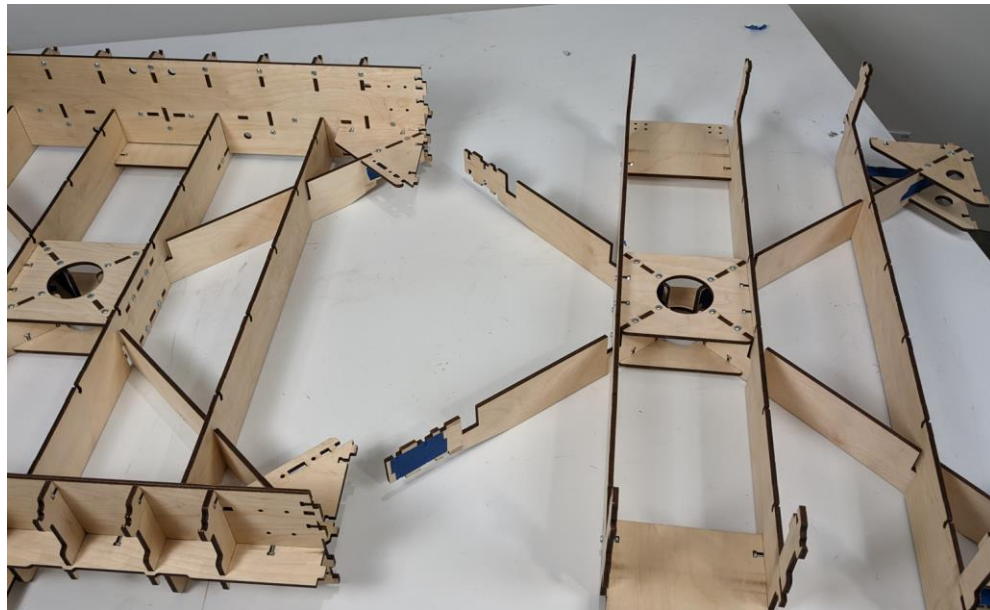

Step 8a Position the Front Assembly to the Rear Assembly, secure with two M4 x 16 Machine Screws to each side as shown.

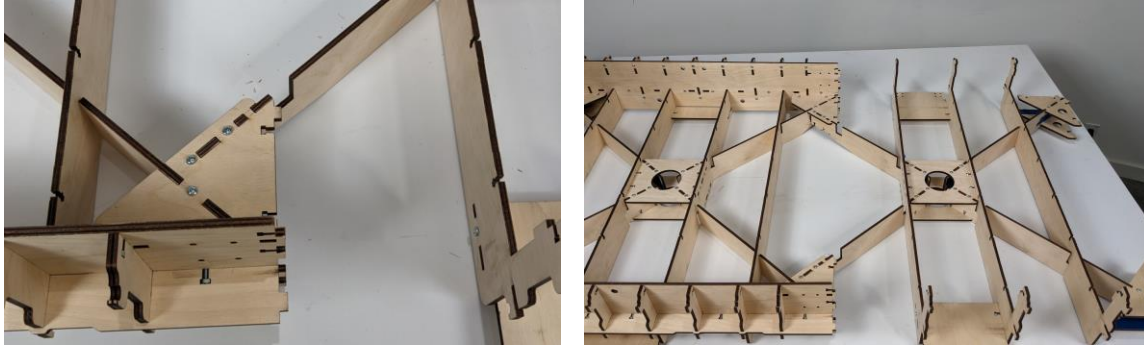

Step 8b Gently, flip entire X-Frame Assembly over and install the remaining two Extension Frame Corner Supports (EQX8) to the X-Frame Assembly, as shown and secure with six M4 x 16 Screws and Nuts.

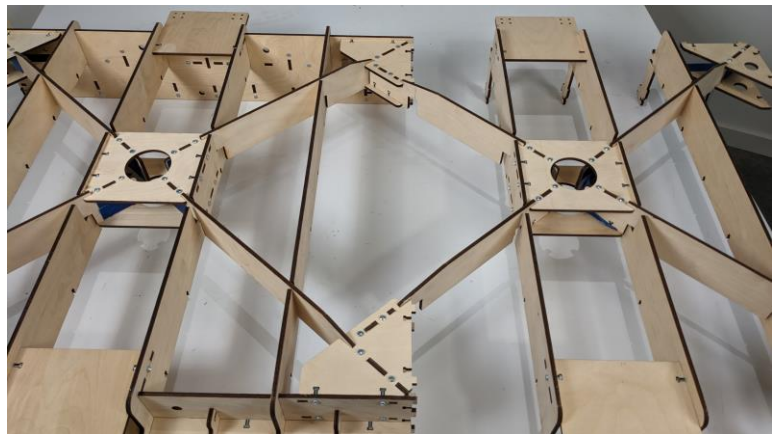
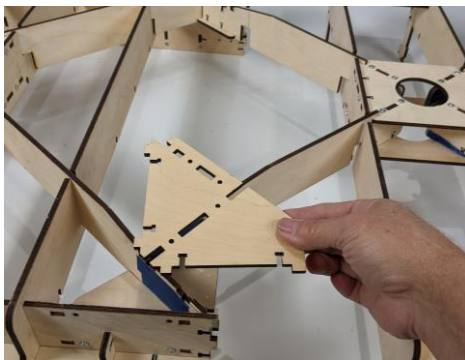

Step 8c Position both Extension Coupling Plates (EQX12) and onto the Extension Frame Mid Support (EQX4), as shown.

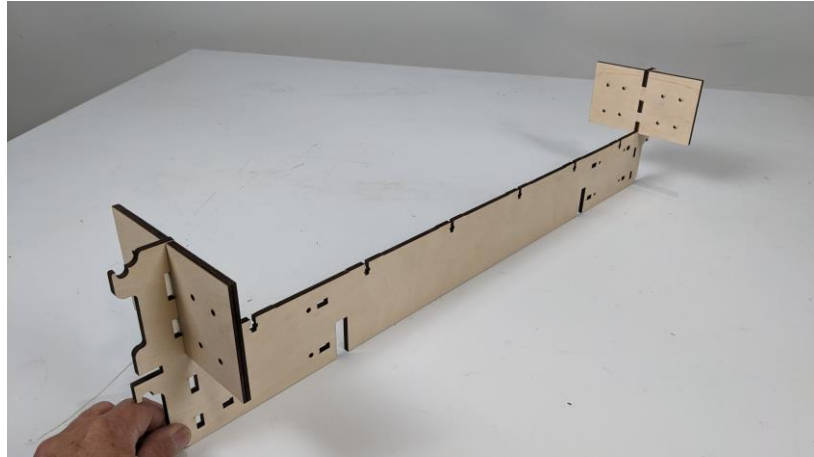

Step 9 Gently, flip the entire X-Frame Assembly back over. Gently and evenly slide the Extension Coupling Assembly onto the X-Frame Assembly. Adjust so that all the tabs are inserted into the slots, as shown. Note that the Extension Coupling Plates are on the outside of the X-Frame Assembly.

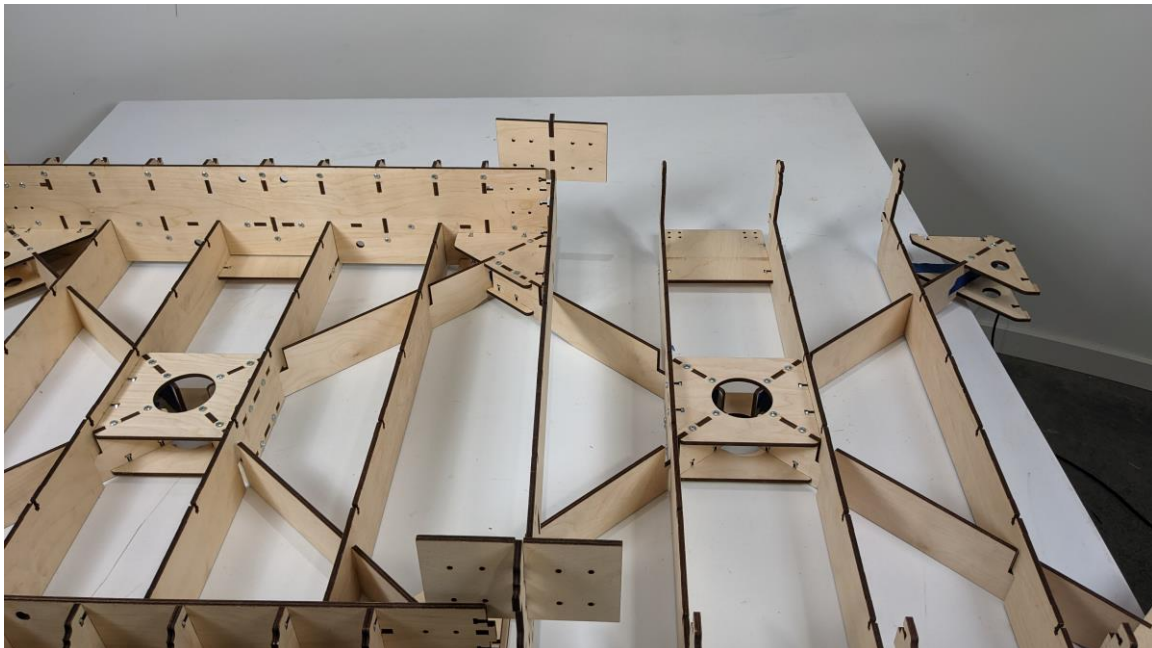

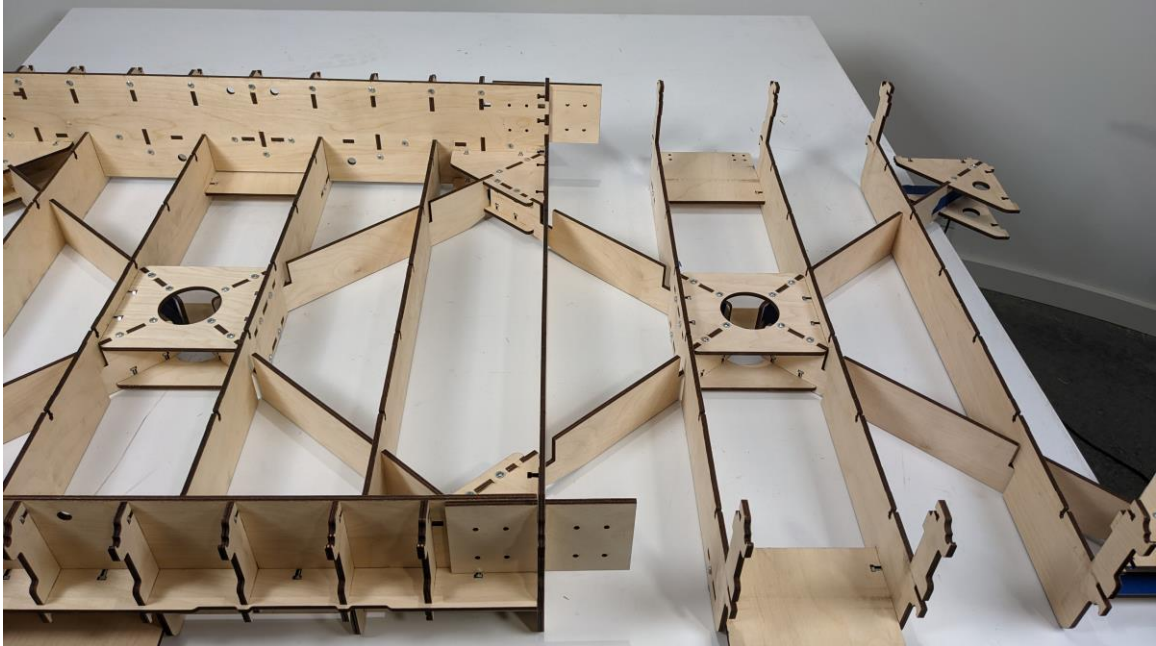

Step 9a Secure the Extension Frame Assembly to the X-Frame Assembly with four M4 x 16 Machine Screws and Nuts on each side, as shown.



Step 10 Attaching the (QX1) Rail Supports to the (QX5) Frame Side Support.

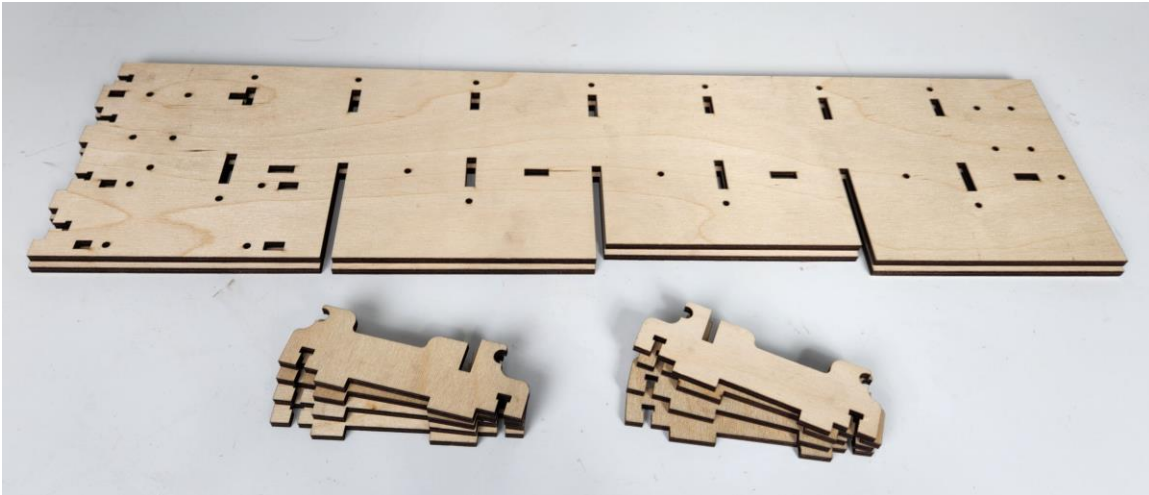

Step 10a Insert the tabs of the eight Rail Supports (QX1) into the corresponding slots of the Extension Frame Side Supports (EQX5) as shown and secure each with two M4 x 16 Machine Screws and Nuts.



Step 11 Attach the Side Frame Assemblies to the X-Frame Assembly as shown.

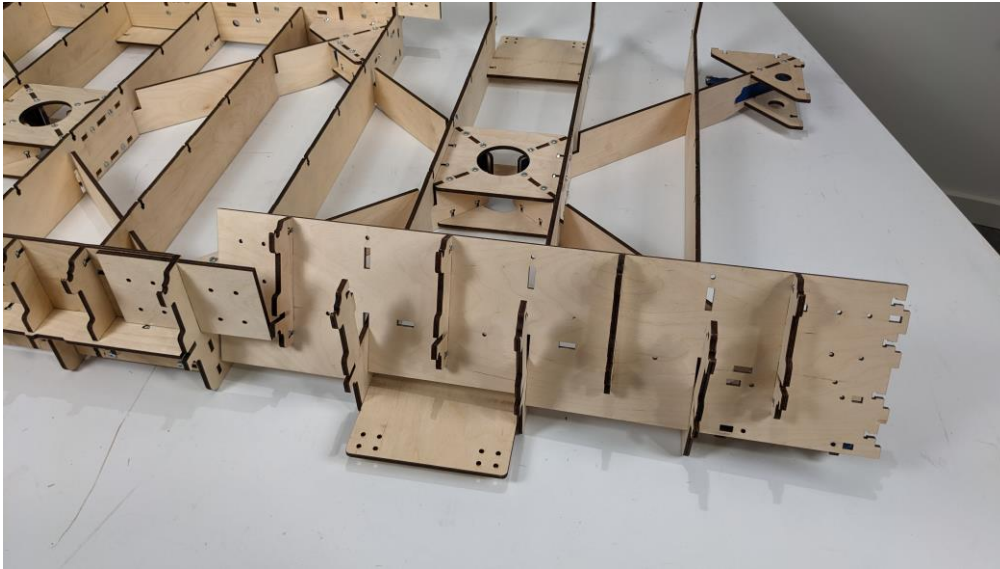

Step 11a Position the tabs of the Frame Corner Support to the X-Frame Assembly, as shown.

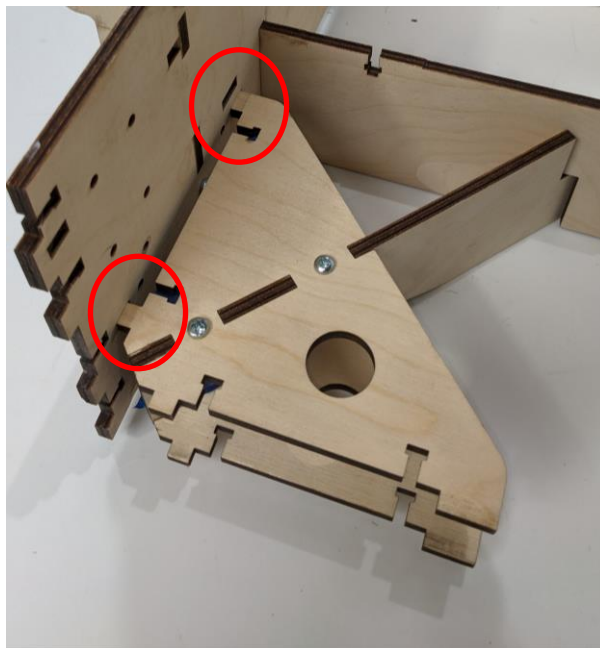

Step 11b Secure each side with seven M4 x 16 Machine Screws and Nuts, as shown.

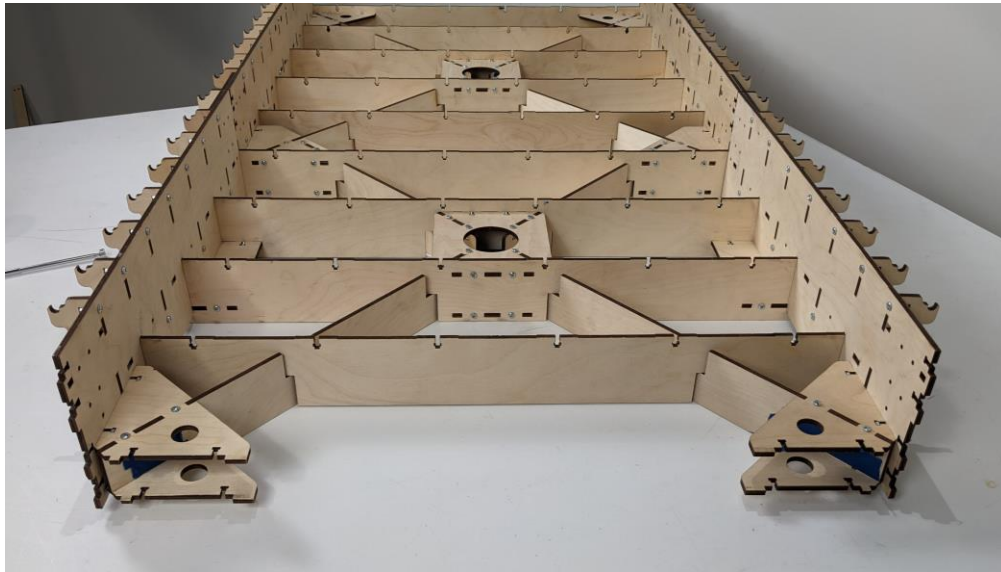

Step 12 Install the Extension Frame Side Brace (EQX10) on each side of the X-Frame Assembly, using five M4 x 16 Machine Screws and Nuts on each side, as shown.

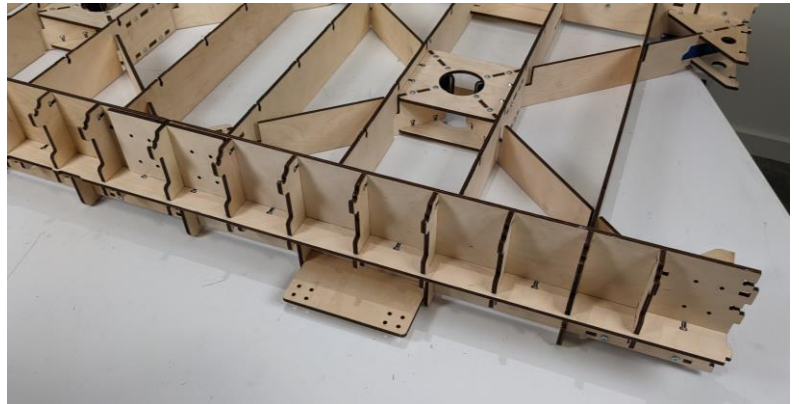
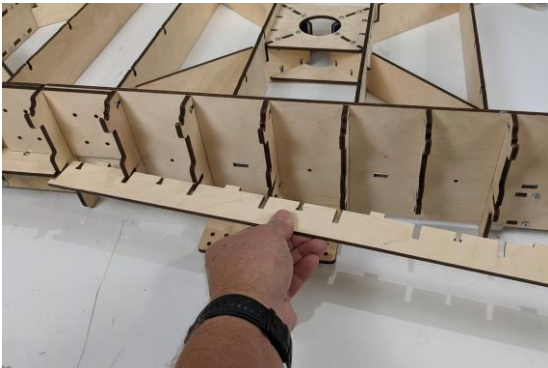

Step 13 Secure the Extension Coupling Plates (EQX12) with eight M4 X 16 Machine Screws and Locknuts each as shown.

Inside view.



Outside view.

Step 14 Install the Belt Supports (QX11) at the Front of the joined Assembly with two M4 x 16 Machine Screws and Nuts each as shown.

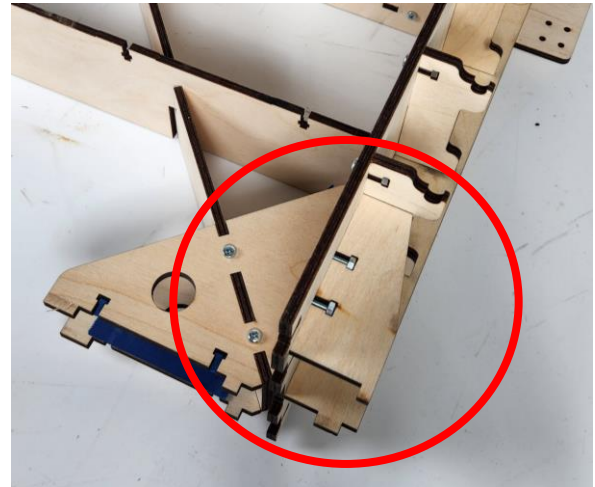
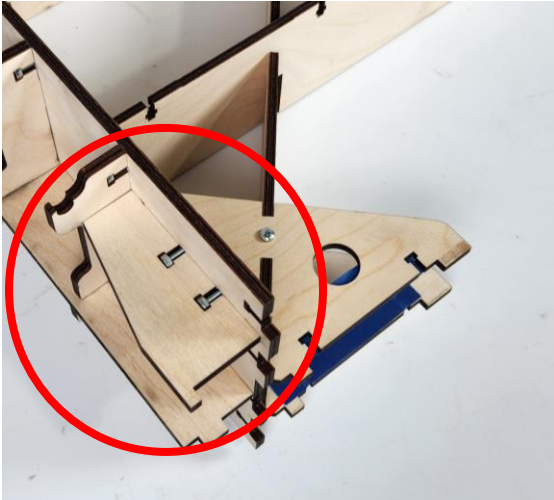

Step 15 Align the tabs and slots of the Frame End Support (QX6) with the tabs and slots of the Side Assembly and secure with eight M4 X 16 Machine Screws and Nuts for each side.

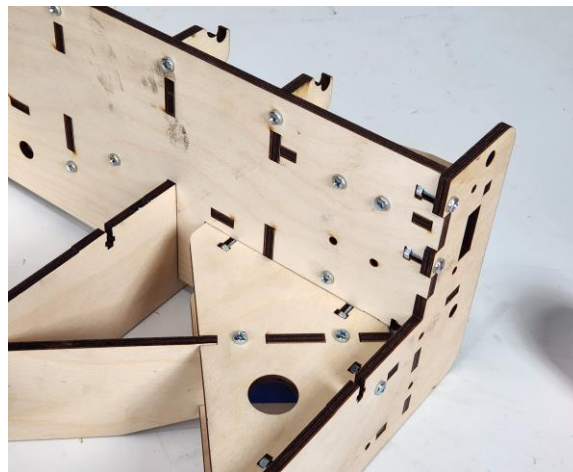

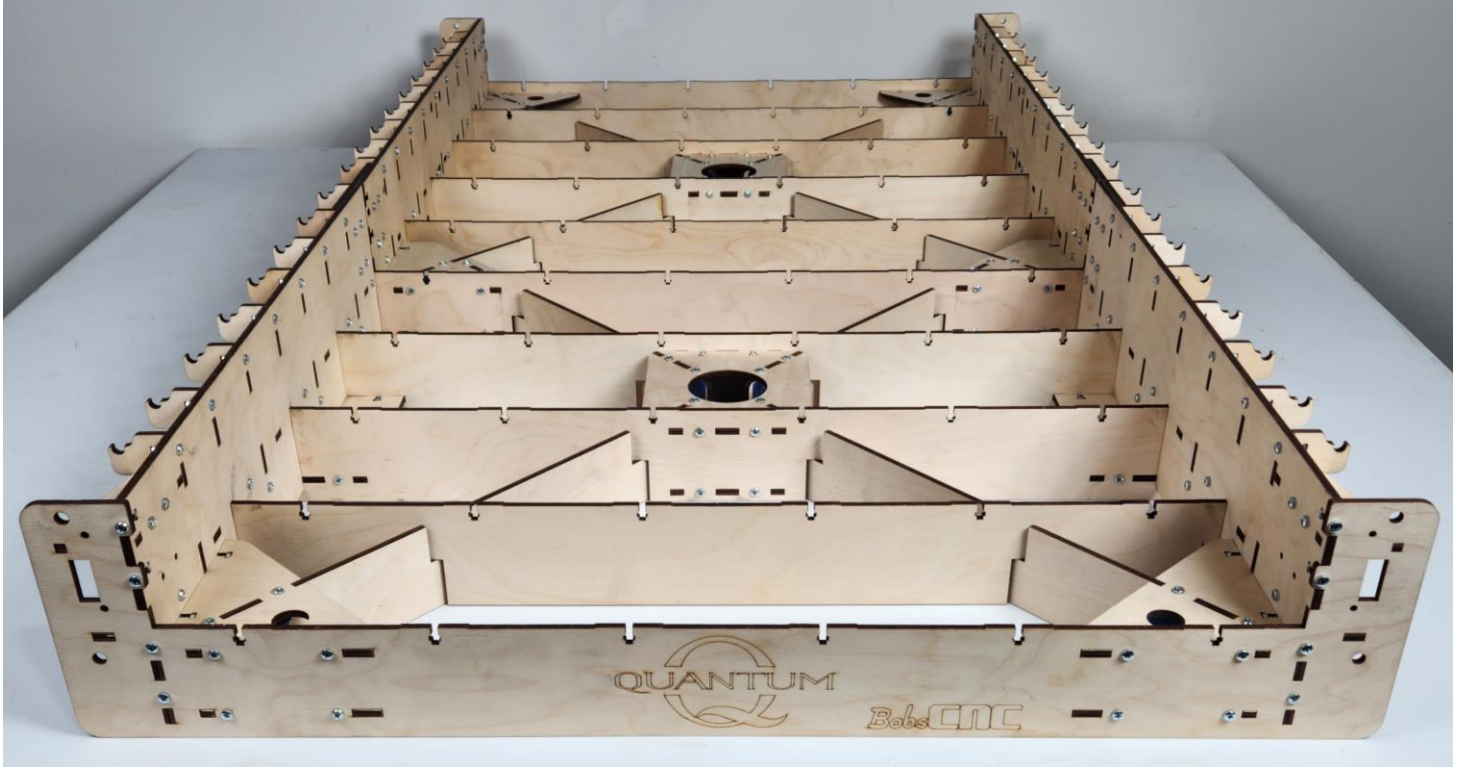

Completed X-Frame Assembly

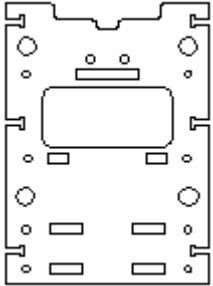
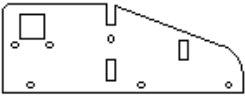
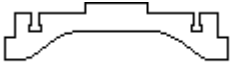
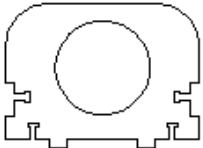
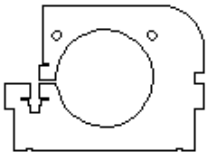
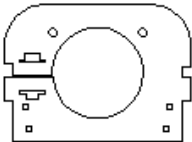
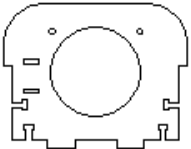

Z Spindle Mount Assembly:

Required Wood Components

Part #	Description	Qty	Photo
QZ1	Back Frame	1	
QZ2	Side Support	2	
QZ3	Top Brace	1	
QZ4	Top Spindle Mount	1	
QZ5	Inner Spindle Mount	1	
QZ6	Mid Spindle Mount	2	
QZ7	Outer Spindle Mount	2	

Required Hardware

Part #	Description	Qty	Photo
H95	M6 x 35 Machine Screws	4	
H18	M6 Locknuts	4	
H40	Eccentric Spacer	4	
H41	Eccentric Washer	4	
H42	Bearing Fender Washer	4	
H44	SG20U Bearing	4	
ZD12	ACME Nut Assembly	1	
H97	M5 X18 Machine Screw	2	
H49	M5 Lock Nut	2	
H14	M4 x 16 Machine Screw	20	
H15	M4 Nut	20	
H48	M5 x 30 Machine Screw	1	
H93	M5 Square Nut	1	

H50	Idler Fender Washer	2	
H85	M4 x 35 Machine Screw	2	
H47	M4 lock Nut	2	

Illustrated Step by Step Instructions

Step 1 Building the SG20U Bearing Assemblies.

NOTE: the Bearing Assembly Order: M6 x 35 Machine Screw (H95), SG20U Bearing(H44) with hub facing toward the Bearing Fender Washer, then the Bearing Fender Washer (H42), Eccentric Washer (H41), Eccentric Spacer (H40), M6 Locknut (H18).

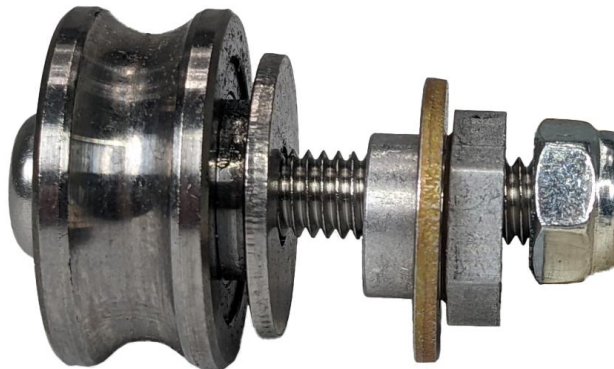



When inserting the Bearing Assembly through the Back Frame (QZ1), make sure the Hub of the SG20U Bearing faces the Bearing Fender Washer which is pressed against the wood.



Step 1a Insert the four bearing Assemblies through the mounting holes in the Back Frame (QZ1) with the Bearing Fender Washer (H42) against the wood and the Hub against the Bearing Fender Washer as shown below.



Step 1b

Slide the Eccentric Washer (H41) over the Eccentric Spacer (H40), inserting the shaft of the M6 x 35 Machine Screw (H95) through the Eccentric Spacer as shown.

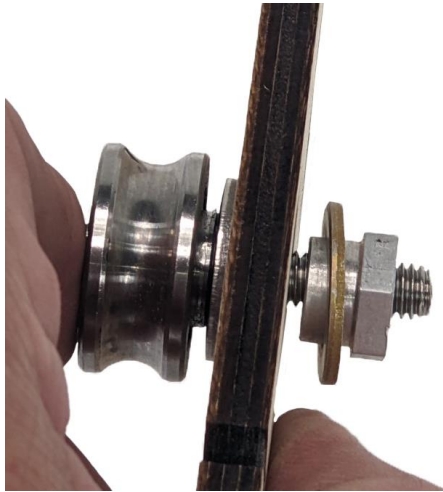

Secure the Bearing Assembly in place with an M6 Lock Nut (H18) on each of the four Assemblies.

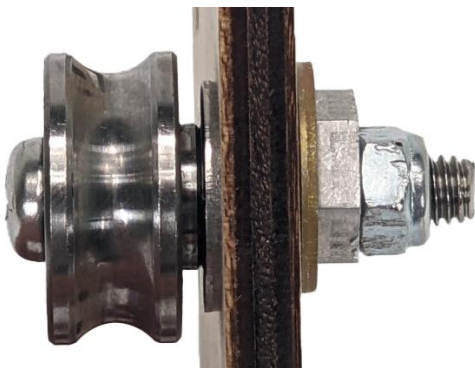

Step 2 Building the Router Mount.

Step 2a Slide the two Idler Fender Washers (H50) onto the M5 x 30 Machine Screw (H48) and secure with the M5 Square Nut (H93).

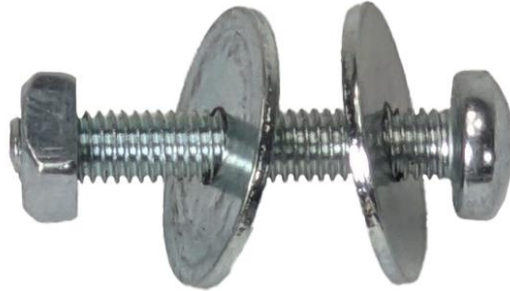

Step 2b Place the Screw, Nut and Washer Assembly into the Inner Spindle Mount (QZ5). Be sure the Square Nut and Washers are nested into their slots, as shown.

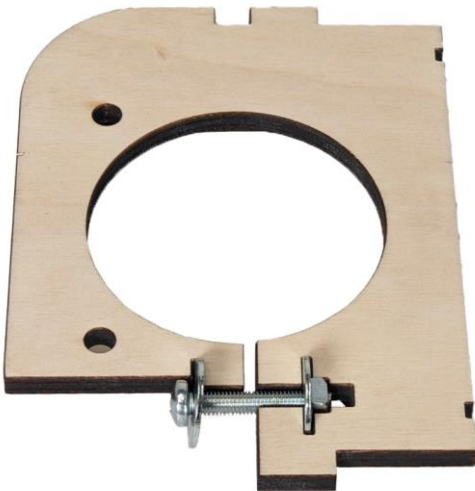

Step 2c Position the Mid Spindle Mount (QZ6) over the Inner Spindle Mount (QZ5), and the Screw, Nut and Washer Assembly as shown.

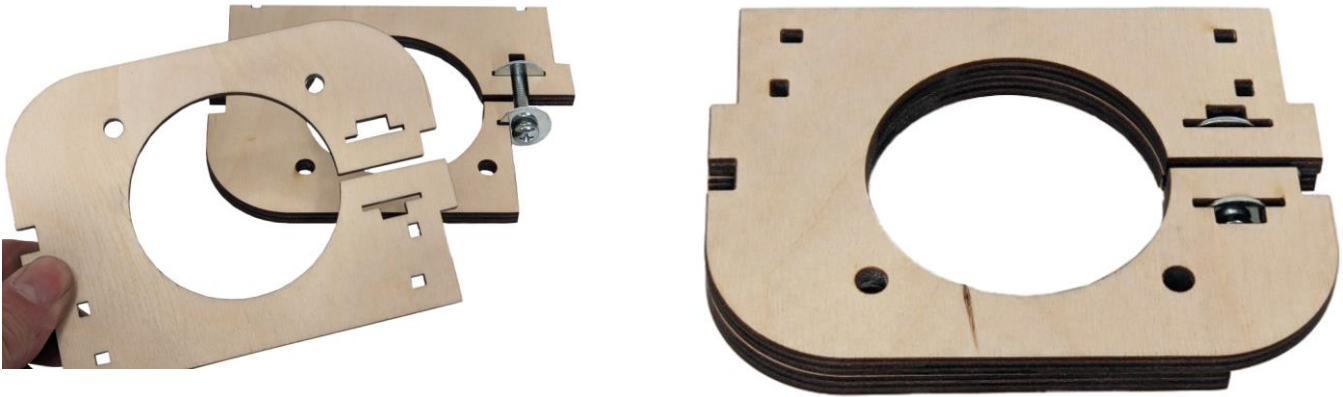

Step 2d Making sure the Screw, Nut and Washer Assembly stay in place, carefully turn the Spindle Mount Assembly over and cover with the second Mid Spindle Mount (QZ6) as shown.



Step 2e Install the two Outer Spindle Mounts (QZ7) on the top and bottom of the Router Mount Assembly.



Step 2f

While holding the Assembly stack together, insert two M4 x 35 Machine Screws (H85) through the bottom of the Assembly and secure with two M4 Lock Nuts (H47) as shown.

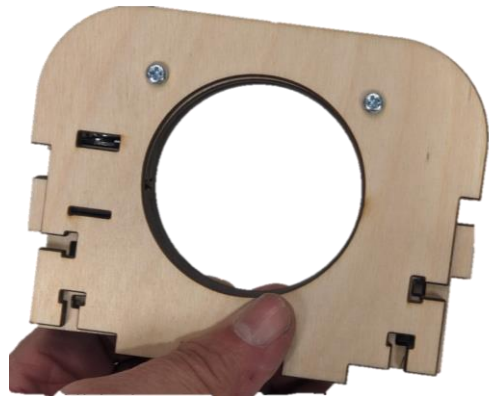
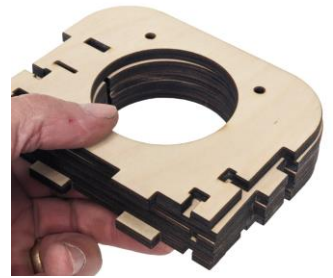



The Assembly stack can be oriented so that the slot for securing the Router is located on either the left or right side with the curved front corners facing you.

Step 2g Align the tabs of the stack with the slots in the Back Frame Assembly and secure with four M4 x16 Machine Screws and Nuts. You may find it helpful to set the two M4 Nuts in the top before fully seating the tabs.





Step 2h Align the tabs of the Top Spindle Mount (QZ4) with the slots in the Back Frame Assembly and secure with two M4 x 16 Machine Screws and Nuts as shown.

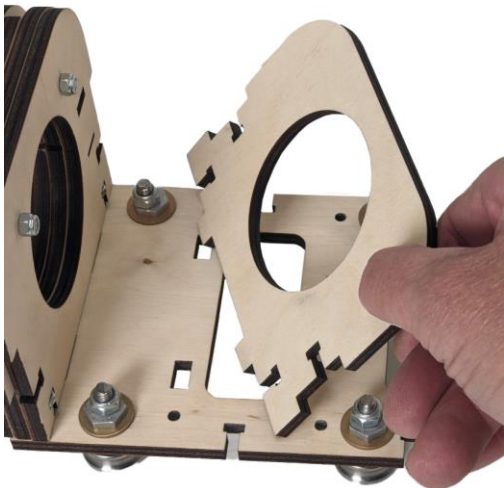

Step 2i

Align the tabs of the Top Brace (QZ3) with the slots in the Back Frame Assembly and secure with two M4 x 16 Machine Screws and Nuts as shown.

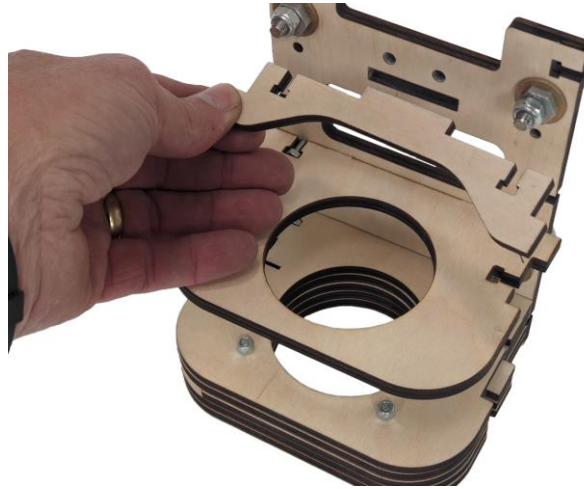

Step 2j

Align the tabs of the Router Mount Assembly with the slots in the Side Support (QZ2) and secure with six M4 x 16 Machine Screws and Nuts. Repeat to install the other Side Support.

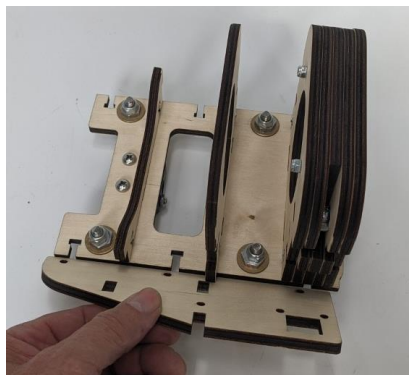

Step 2k Prepare the ACME Nut Assembly (ZD12) by inserting two M5 Lock Nuts (H49) in the ACME Block. Note: Make sure the nylon washer on the top of the Lock Nut is visible after inserting as shown.



Step 2l Insert two M5 x 18 Machine Screws (H97) through the Router Mount Assembly as shown and secure the ACME Nut Assembly in place as shown.



NOTE: The slot in the ACME Nut must be oriented on the bottom as shown.

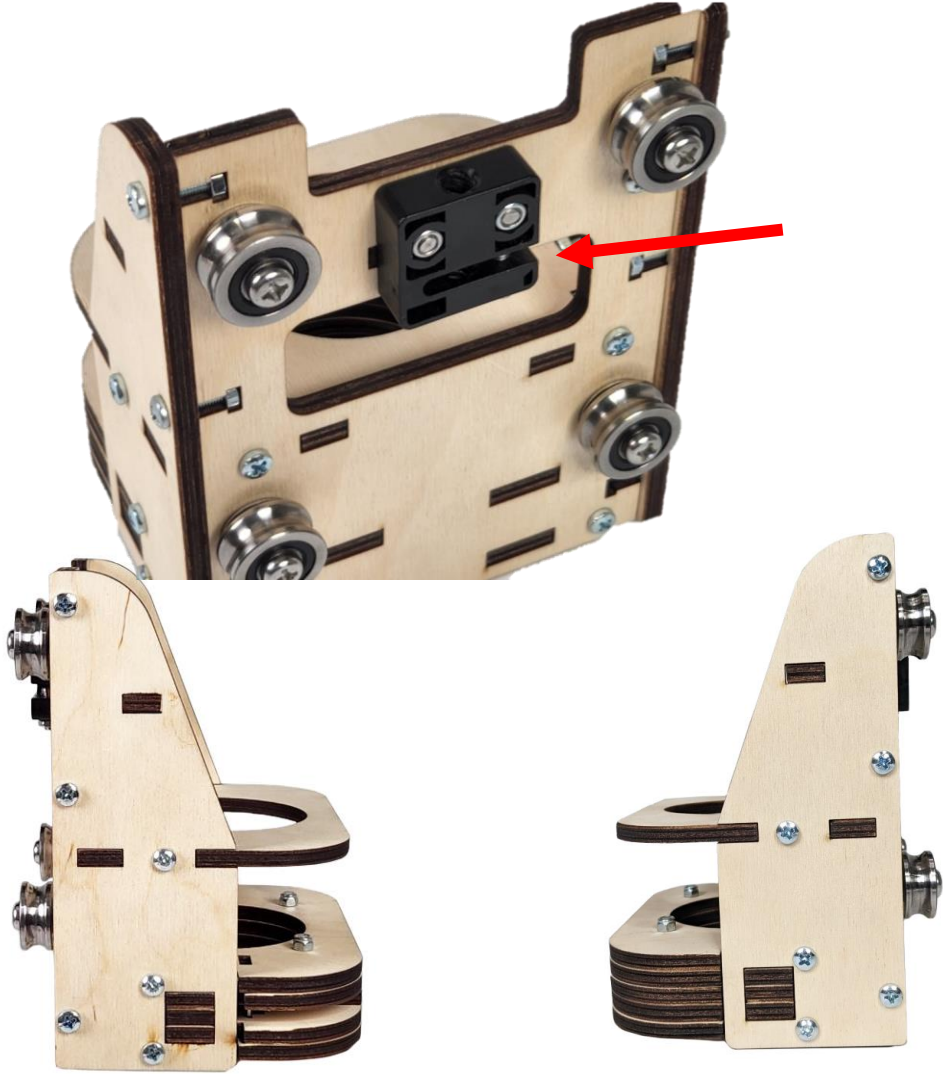





Left Side

Right Side

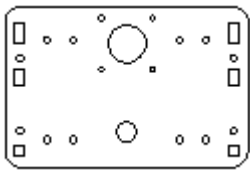
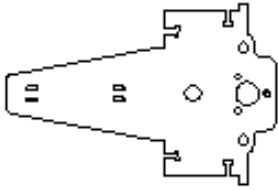
Y Carriage Assembly and Z Assembly

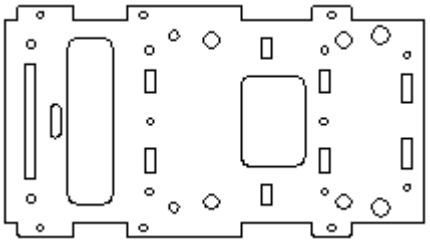
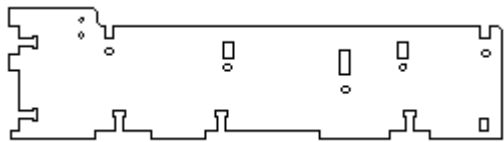
Required Wood Components

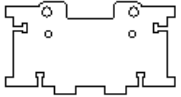

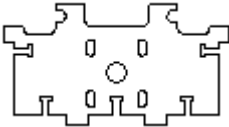
Part #	Description	Qty	Photo
QY1	Z Stepper Motor Mount	1	 A rectangular wooden plate with a central circular hole and several smaller holes around the perimeter.
QY2	Carriage Top Support	1	 A complex wooden shape with a pointed left side and a central circular hole.
QY3	Bearing Retainer Plate	1	 A small, rectangular wooden plate with a central circular hole.
QY4	Carriage Frame	1	 A large, rectangular wooden plate with a central rectangular cutout and several smaller holes.
QY5	Carriage Side Support	2	 A long, narrow wooden plate with a complex shape and several holes.
QY6	Z Rail Stop	1	 A small, rectangular wooden plate with a central hole.
QY7	Carriage Bottom Support	1	 A small, rectangular wooden plate with a complex shape and several holes.

QY8	Outer Rail Support	2	
-----	--------------------	---	--

Required Hardware

Part #	Description	Qty	Photo
H95	M6 x 35 Machine Screws	4	
H18	M6 Locknuts	4	
H40	Eccentric Spacer	2	
H41	Eccentric Washer	2	
H42	Bearing Fender Washer	6	
H44	SG20U Bearing	4	
H57	Bearing Retainer Washer	3	
H98	M4 x 20	5	
H47	M4 Lock Nut	5	

CB11	Stepper Motor	1	
H37	M3 x 10 Machine Screw	4	
H88	M3 washer	4	
ZD5	Aluminum Helical Coupler	1	
ZD3	626-2RS Bearing	1	
ZD4	6mm Split Locking Collar	1	
ZD1	ACME Screw	1	
H66	Small Shim Washer	2	
H15	M4 Nut	30	
H14	M4 x 16 Machine Screw	30	
H54	Stress Proof Steel Z-Rail	2	

CB19	Home Switch	1	
H27	M2.5 x 16 Machine Screw	2	
H43	M2.5 Lock Nut	2	

Illustrated Step by Step Instructions

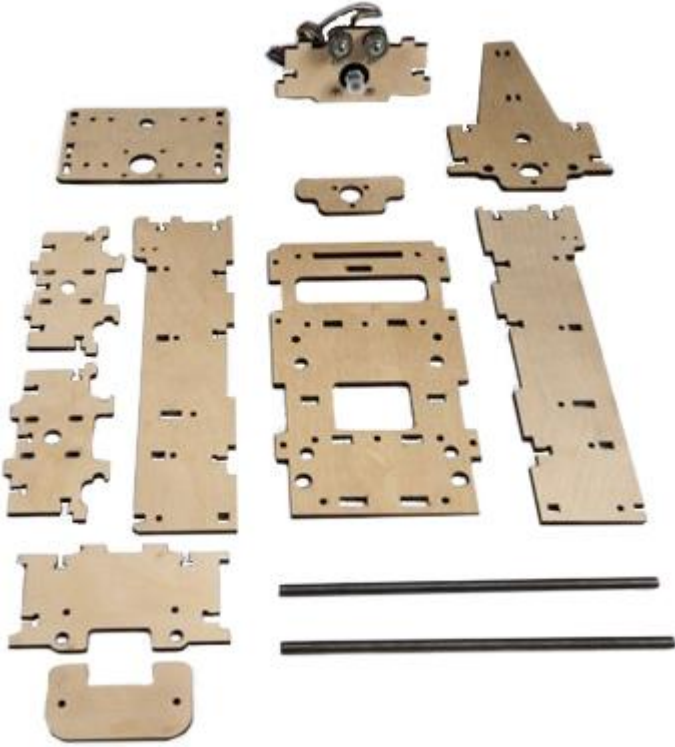

Step 1 Installing the Upper and Lower Bearings

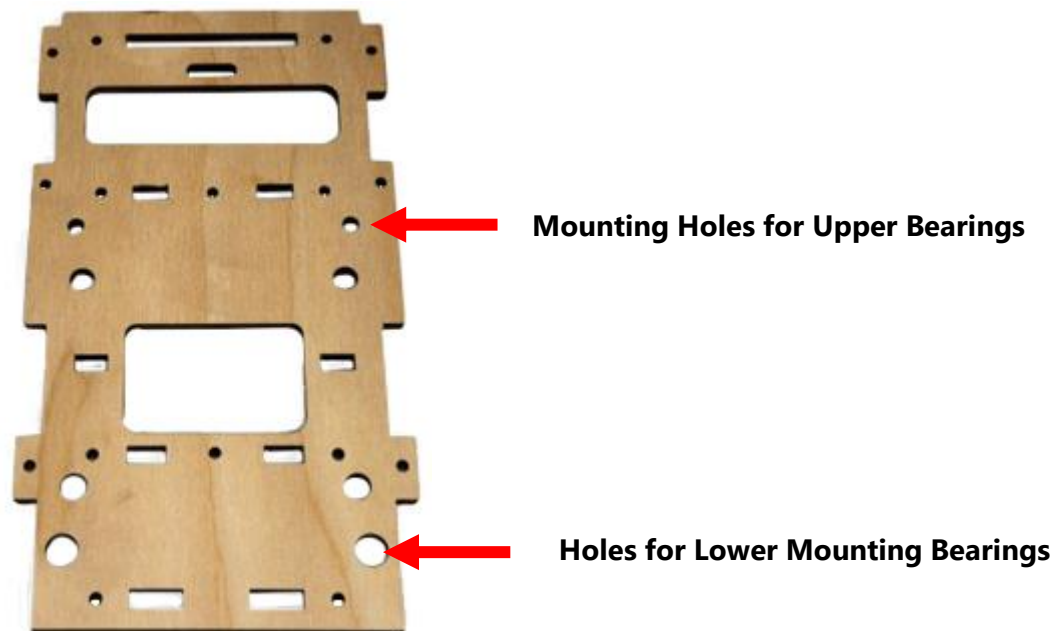

Step 1a

Install the two Upper SG20U Bearing Assemblies for the Carriage Frame (QY4). The assembly order for the Upper Bearing: M6 x 35 Machine Screw (H95), SG20U Bearing(H44) with hub facing toward the Bearing Fender Washer, then the Bearing Fender Washer (H42), Plywood, Bearing Fender Washer (H42) secured with a M6 Lock Nut (H18) as shown.



Step 1b

Install the two lower SG20U Bearings for the Y Carriage Assembly as shown. The assembly order for the Lower Bearings: M6 x 35 Machine Screw (H95), SG20U Bearing (H44) hub facing toward the Bearing Fender Washer, Bearing Fender Washer (H42), Plywood, Eccentric Washer (H41), Eccentric Spacer (H40) secured with a M6 Lock Nut (H18).

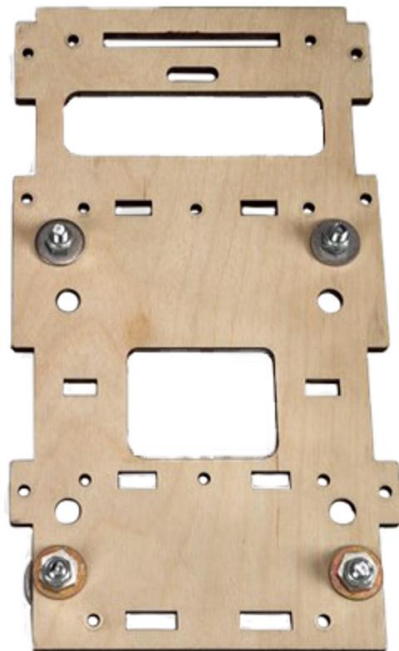

Carriage Frame Front View

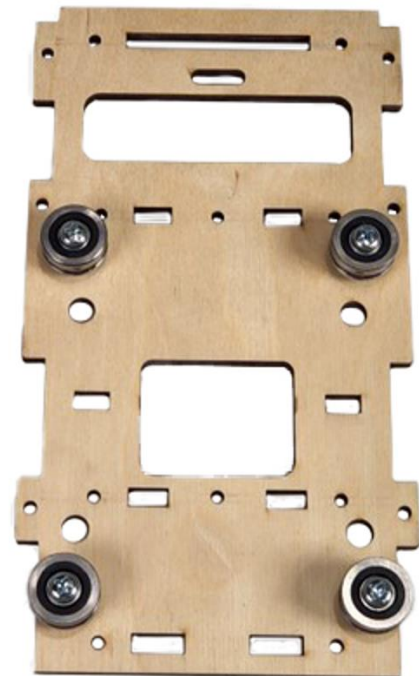

Carriage Frame Rear View

Step 2 Building the Y Carriage Assembly

Step 2a With the Bearings facing down, align the tabs of the Carriage Bottom Support (QY7) with the slots at the bottom of the Y Carriage Assembly and secure with two M4 x 16 Machine Screws and Nuts.



Step 2b Align the tabs of the Outer Rail Support (QY8) with the slots located below the opening in the Y Carriage Assembly and secure with three M4 x 16 Machine Screws and Nuts.



Step 2c Align the tabs of the remaining Outer Rail Support (QY8) with the next set of slots above in the Y Carriage Assembly and secure with three M4 x 16 Machine Screws and Nuts.

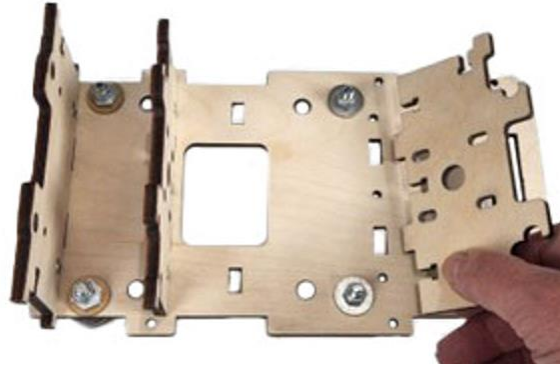

Step 2d Slide the narrow tongue of the Carriage Top Support (QY2) through the long narrow slot at the top of the Y Carriage Assembly as shown. Secure with two M4 x 16 Machine Screws and Nuts.

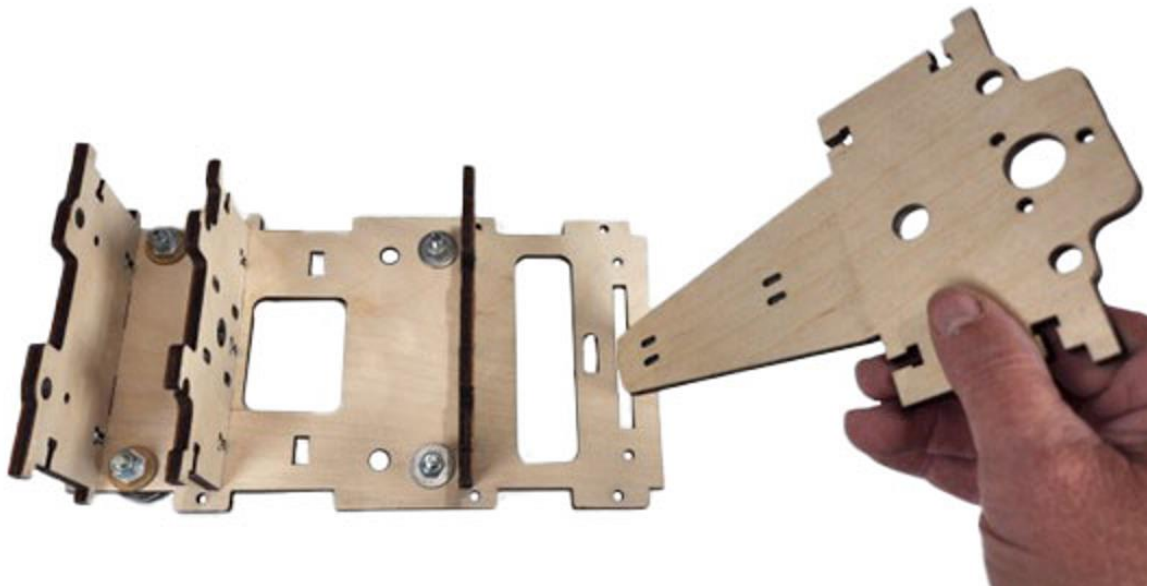

Step 2e Carefully thread the Dupont Connector and the Stepper Motor wires of the Y Stepper Motor Assembly through the upper Outer Rail Support middle hole.



Continue threading the wires through the rectangular hole just beneath the Carriage Top Support.

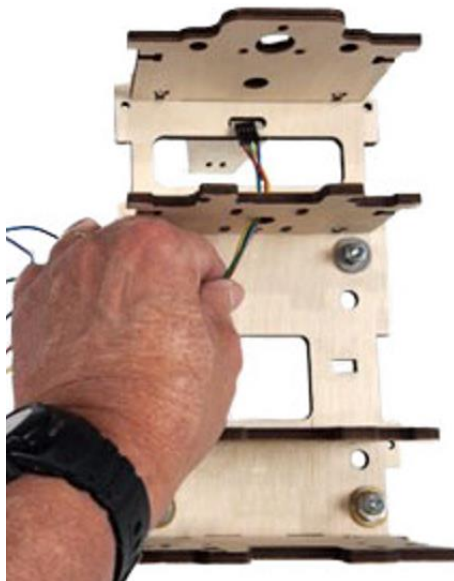

Step 2f With most of the wire threaded through the Y Carriage Assembly, align the tabs of the Y Stepper Motor Assembly with the corresponding slots in the Carriage Frame Assembly.

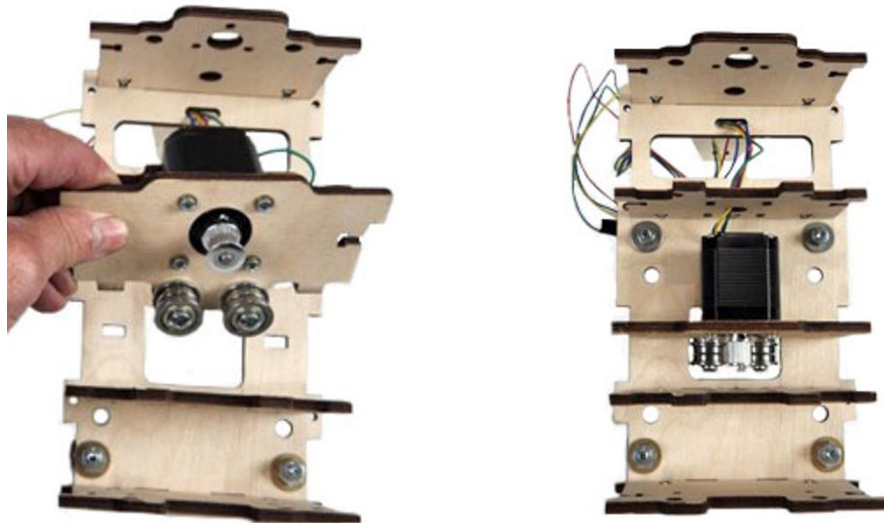

Step 2g Align the tabs and slots of the Carriage Side Support (QY5) with the Y Carriage Frame Assembly and secure with eight M4 x 16 Machine Screws and Nuts.

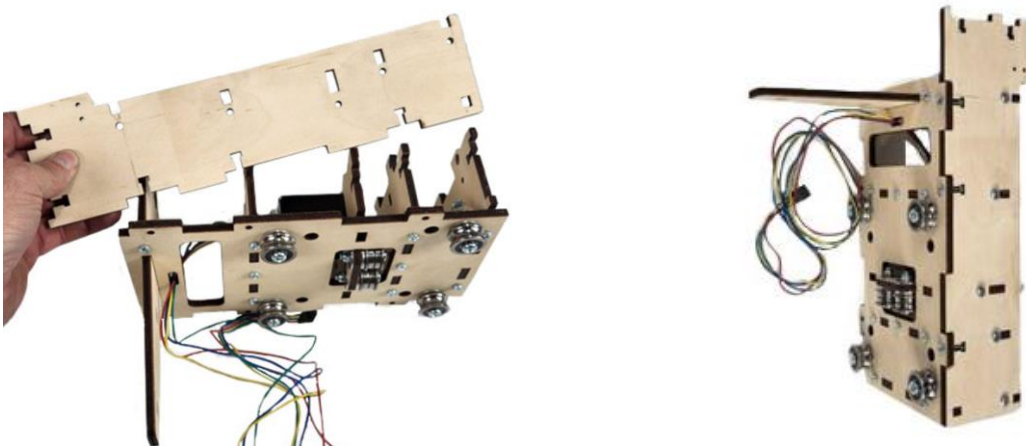

Repeat to attach the other Carriage Side Support.

Step 2h Attach the Z Rail Stop (QY6) to the bottom of the Y Carriage Frame Assembly and secure with two M4 x 20 Machine Screws (H98) and M4 Lock Nuts (H47).



Step 3 Attaching the Z Frame Assembly to the Y Carriage Frame Assembly



This closeup view shows the Locknut tightened against the Eccentric Spacer. Note the space between the faces of the locknut and those of the Eccentric Spacer. This will indicate the position of the SG20U Bearing and the Rail.

Step 3a

With the Locknut firmly snugged against the face of the Eccentric Spacer, use a 13mm socket to turn just the Eccentric Spacer as shown.

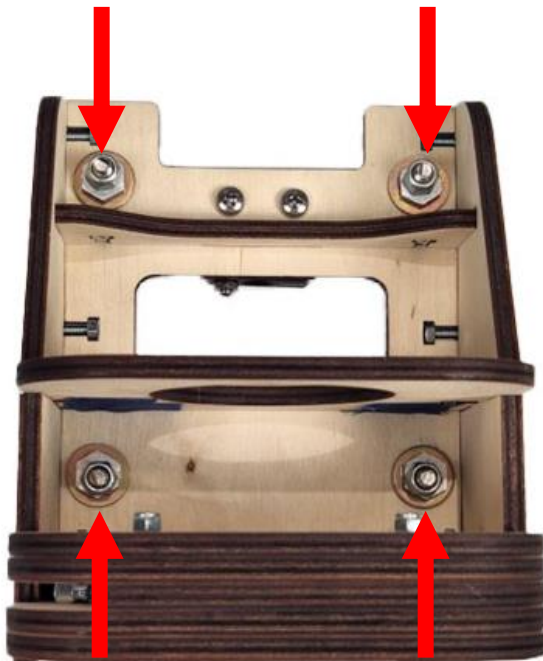

IMPORTANT

Make sure the points on the wide edge of the Eccentric Spacers of the upper bearings are pointing down and the wide point of the lower Eccentric Spacers are pointing up as shown.

Step 3b Carefully set the Z Carriage Frame onto the Y Carriage Assembly as shown.

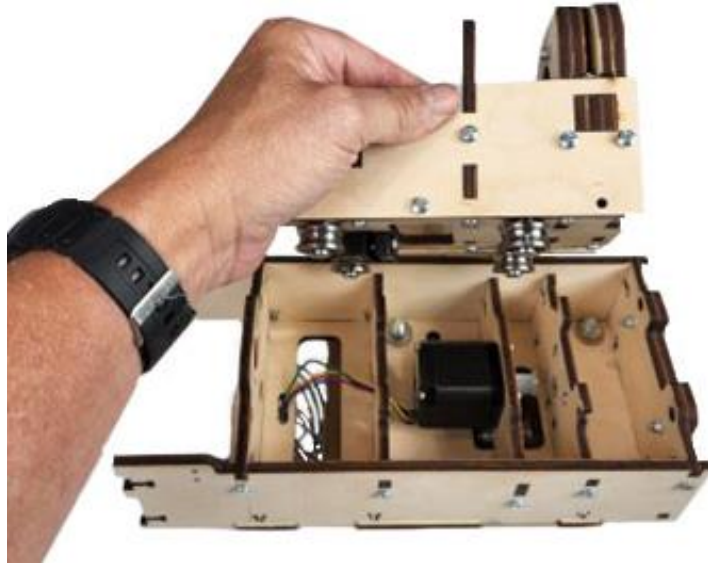

Step 3c Carefully slide the Z Rail (H54) through the hole in Carriage Top Support (QY2), through both Outer Rail Supports (QY8) and past the Bearings until it is seated at the bottom of the Y Carriage Assembly.



Top View



Bottom View



Step 4 Installing the Acme Screw.

Step 4a Thread the Acme Screw Assembly through the hole located at the front of the Carriage Top Support (QY2) and into the Acme Nut. Rotate the Acme Screw Assembly through the Acme Nut until the bearing touches the Carriage Top Support. Then turn Acme Screw just until Z Carriage begins to rise up the Rail.



Step 4b Place the Bearing Retainer Plate (QY3) over the ACME Screw Assembly and secure with three M4 x 20 (H98) Machine Screws and Bearing Retainer Washers (H57), and M4 Locknuts (H47).

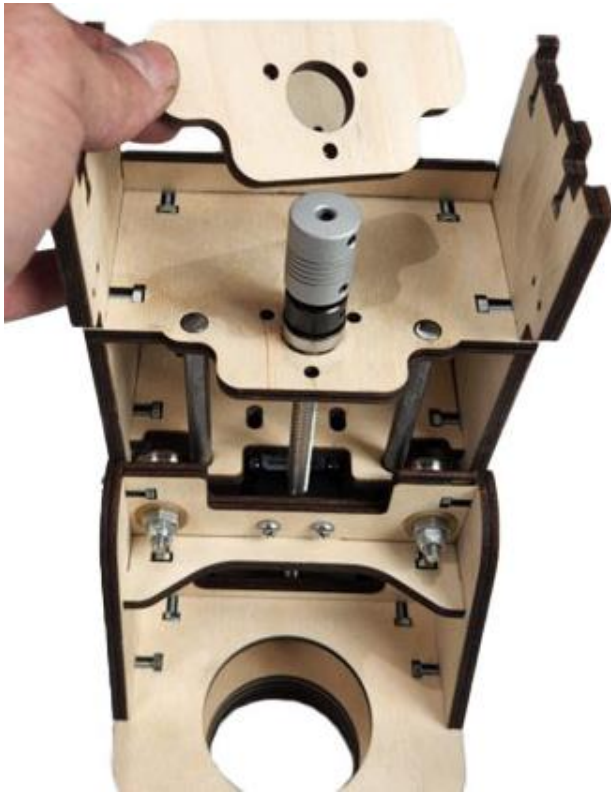



The Bearing Retainer Washers overlap the Bearing race to hold it in place.

Step 5 Installing the Z Home Switch.

Step 5a Align Home Switch Arm down as shown. Secure Home Switch with two M2.5 X 16 Machine Screws (H27) and Locking Nuts (H43). Install the Screws so that the heads are outside the Carriage Side Support with Lock Nuts against the switch housing. Do not over tighten.

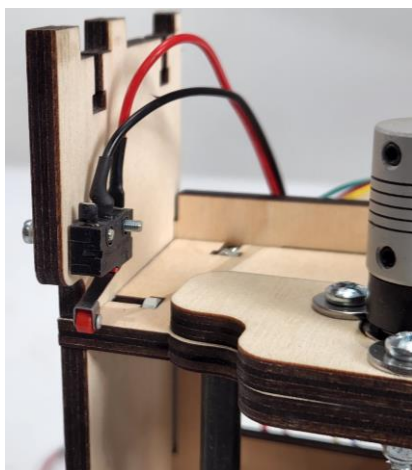

Step 5b Route the Home Switch wire down through the access hole and through the elongated hole in the Carriage Frame, as shown.

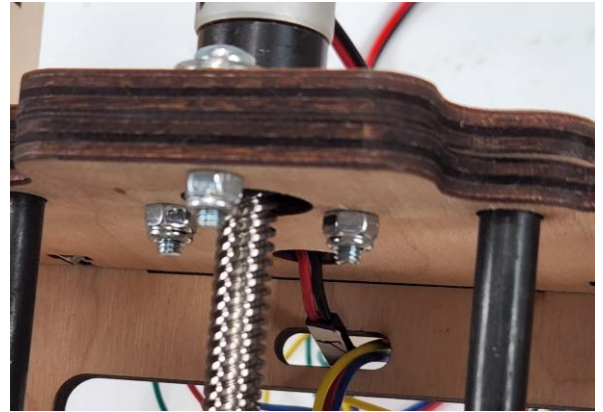
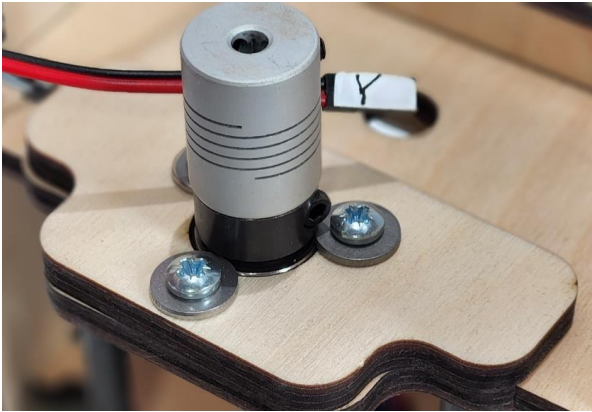

Step 6 Installing the Z Stepper Motor.

Step 6a Mount the Z Stepper Motor through the large hole in the (QY1) Z Stepper Motor Mount. Secure with four M3 x 10 Machine Screws (H37) and M3 Washers (H88).

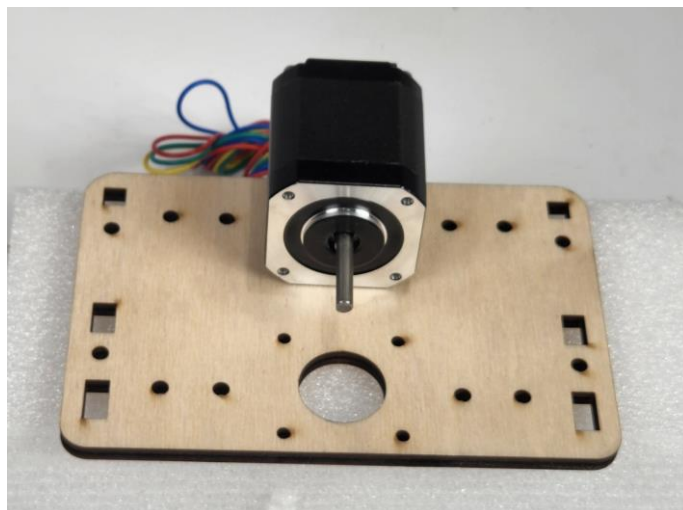

Step 6b

Route the Z Stepper Motor wire through the small hole at the back of the Z Stepper Motor Mount as shown.

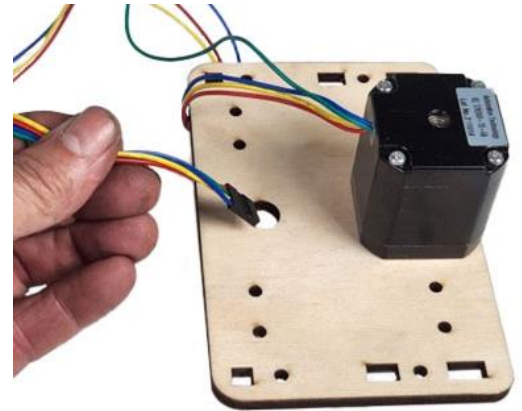

Continue routing the wires through the Carriage Top Support (QY2) and the small rectangular hole in the Carriage Frame (QY4) beneath the Carriage Top Support as shown.

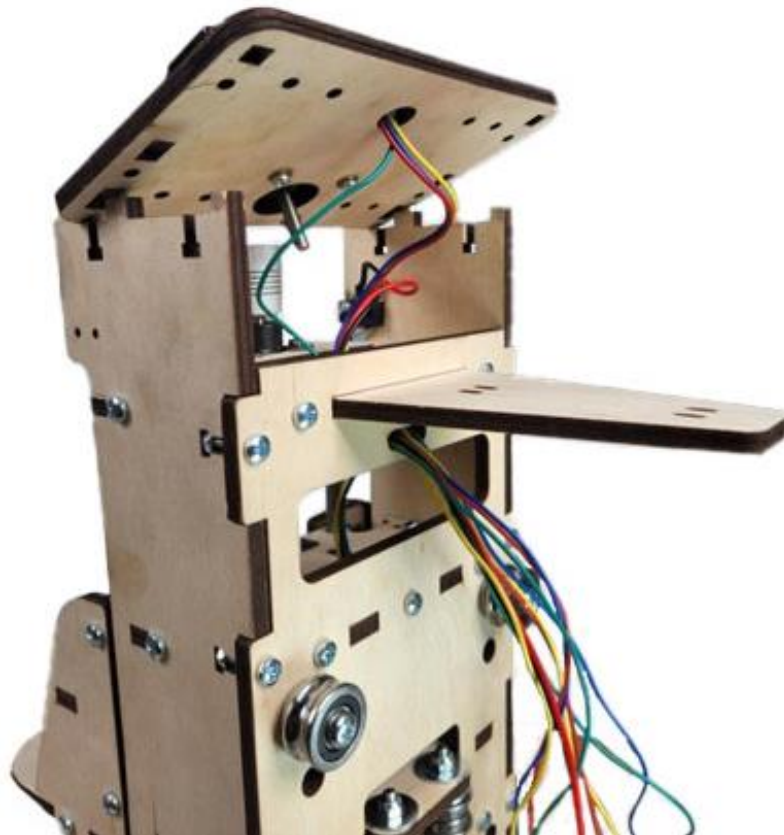

Step 6c Before aligning the tabs of the Carriage Frame Assembly with the slots in the Z Stepper Motor Mount, make sure that the flat of the Stepper Motor shaft lines up with a Set Screw in the Aluminum Helical Coupler as shown.

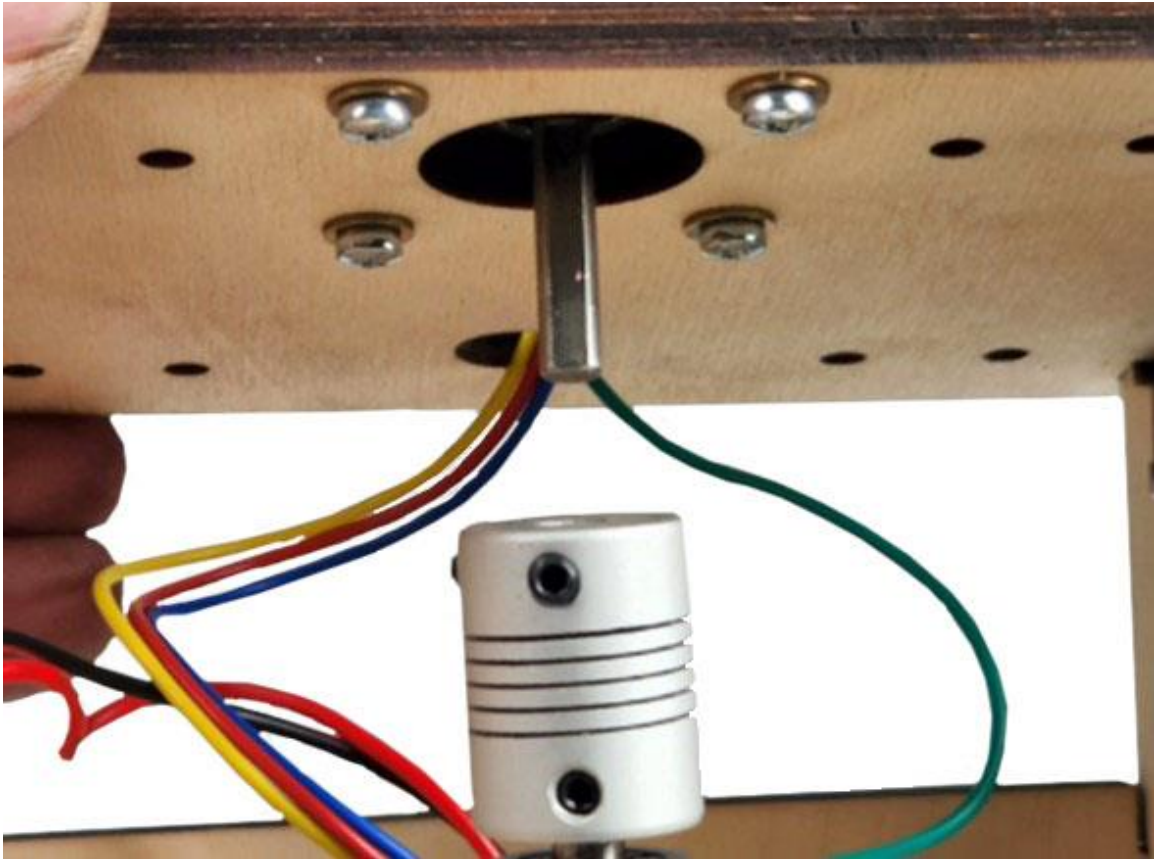

Step 6d Carefully slide the Stepper Motor Shaft into the Aluminum Helical Coupler. Then fit the tabs of the Carriage Frame Assembly into the slots in the Z Stepper Motor Mount and secure with four M4 x 16 Machine Screws and Nuts.

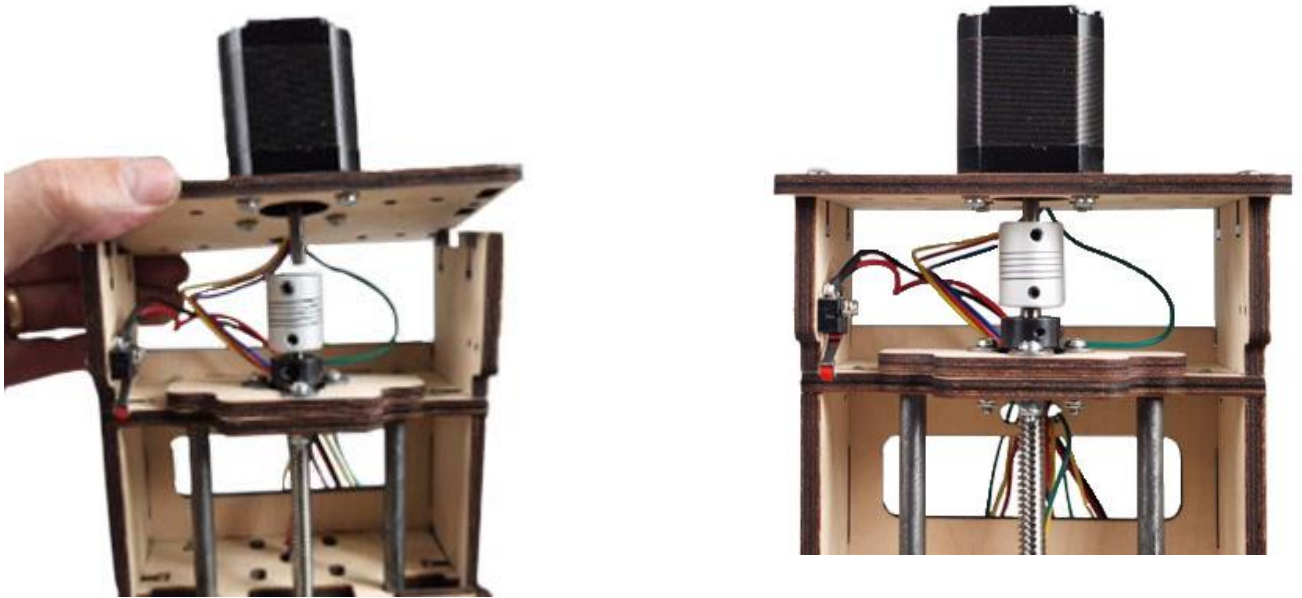



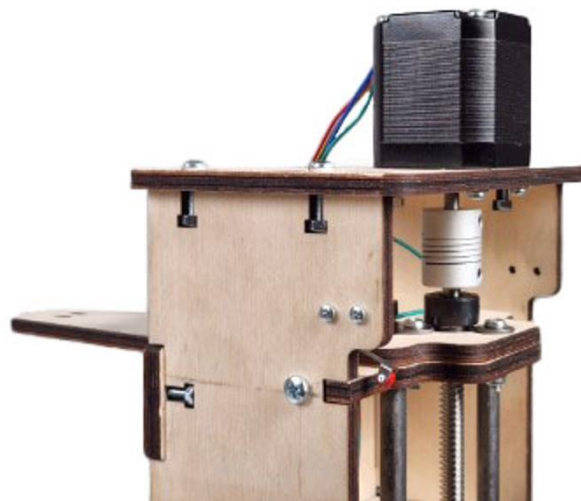

Step 6e Carefully tighten both set screws on the Aluminum Helical Coupler against the Stepper Motor Shaft.

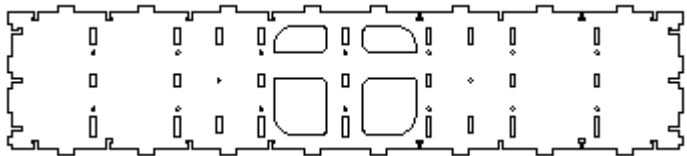
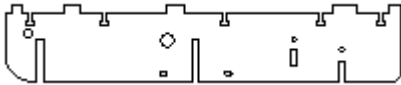
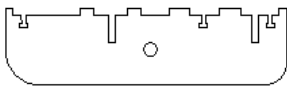

Gantry Assembly

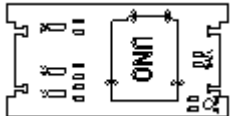

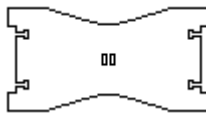
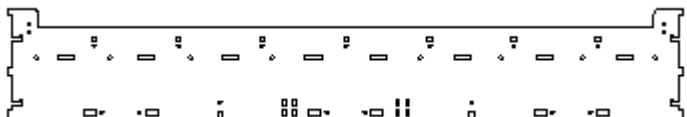

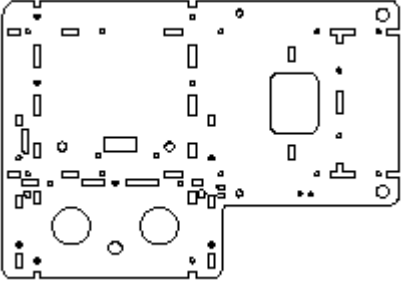
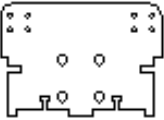
Required Wood Components

Part #	Description	Qty	Photo
QG1	Gantry Frame	1	 A large, rectangular wooden frame with a complex internal structure, including several rectangular cutouts and a central section with two larger, rounded rectangular openings.
QG2	Gantry Side Support	4	 A long, narrow wooden component with a complex profile, featuring several small circular holes and a central vertical slot.
QG3	Gantry Cross brace	4	 A U-shaped wooden component with a central circular hole and several small rectangular notches along its edges.
QG4	Y Rail Support	7	 A complex wooden component with a central Y-shaped cutout and several small rectangular notches along its edges.
QG5	Controller Mount	1	 A rectangular wooden component with a central rectangular cutout containing the text "ONV". It has several small rectangular notches and holes along its edges.
QG6	Gantry Back Brace	2	 A rectangular wooden component with two large circular holes and several small rectangular notches along its edges.
QG7	Gantry Back Support	2	 A rectangular wooden component with a central rectangular cutout and several small rectangular notches along its edges.
QG8	Gantry Top/Bottom Brace	2	 A long, narrow wooden component with a complex profile, featuring several small rectangular notches and holes along its edges.

QG9	Gantry Side	2	
QG10	Gantry Lower Side Brace	2	

Required Hardware

Part #	Description	Qty	Photo
H95	M6 X 35 Machine Screws	8	
H18	M6 Lock Nut	8	
H40	Eccentric Spacer	4	
H41	Eccentric Washer	4	
H42	Bearing Fender Washer	12	
H44	SG20U Bearing	8	
H14	M4 x 16 Machine Screws	120	
H15	M4 Nut	120	

CB19	Home Switch	3	
H27	M2.5 x 16 Machine Screw	6	
H43	M2.5 Lock Nut	6	
H99	Stress Proof Steel XY-Rail (58.75")	4	

Illustrated Step by Step Instructions

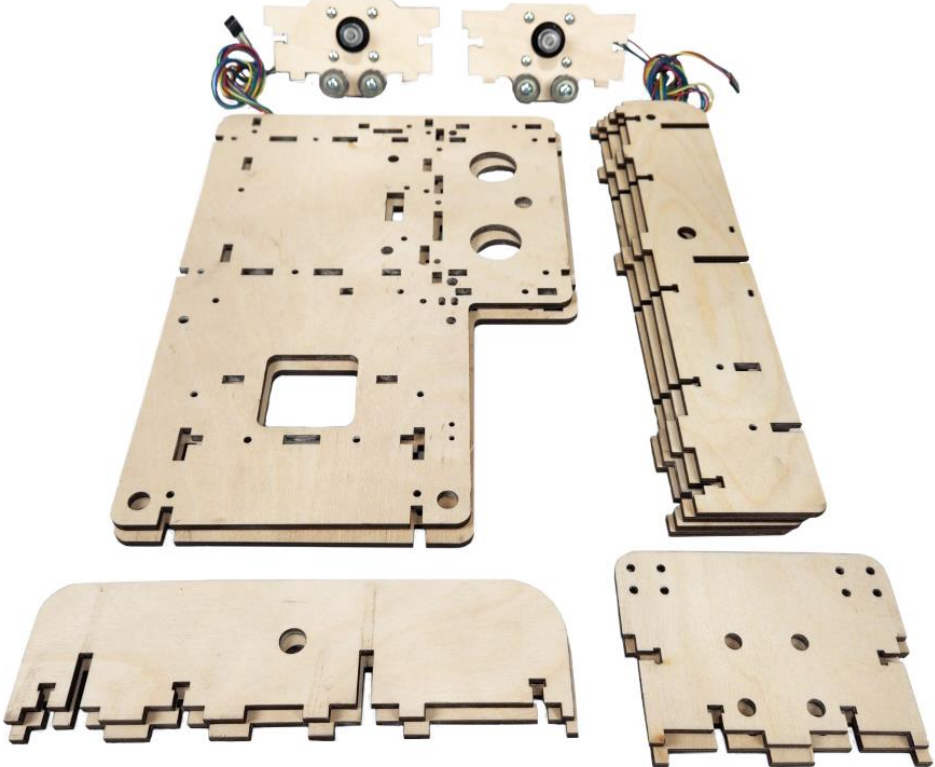

Step 1 Building the Gantry Side Assemblies.

NOTE: The two Side Assemblies will mirror each other when completed. Prior to the assembly process, orient the parts of the side you are building as shown.

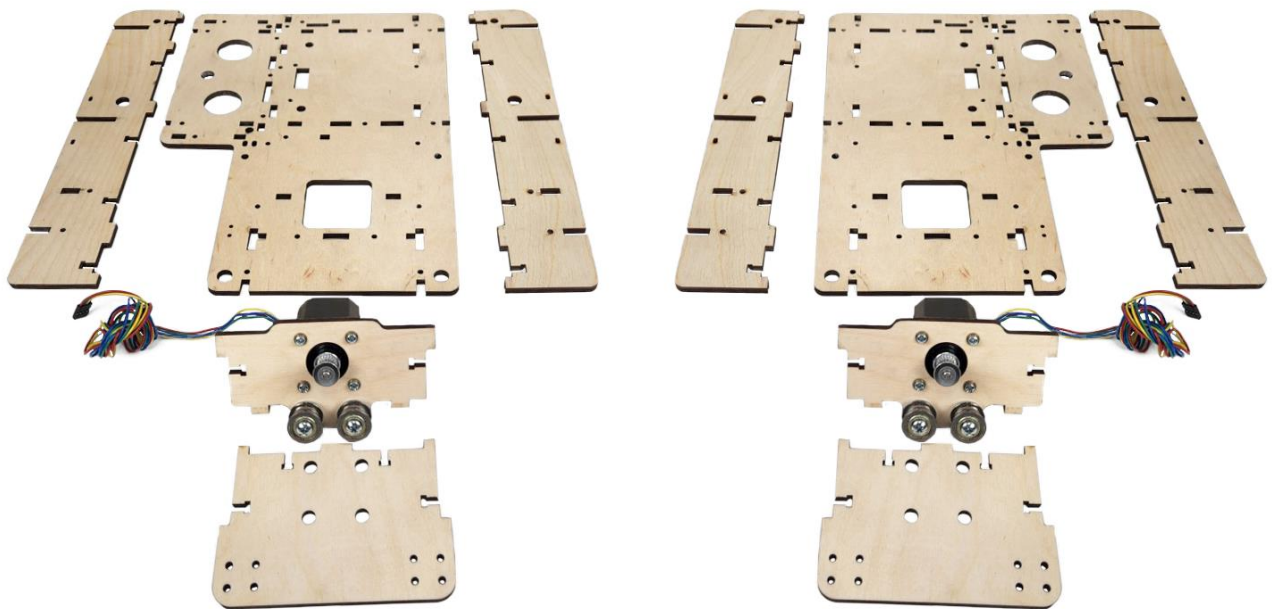

Step 1a Layout two Gantry Side Supports (QG2) and a completed Stepper Motor Mount Assembly. Be sure that with the Idler Bearings resting on the table (as shown below), ensure the Stepper Motor Wires are oriented in the correct direction as shown in the photo below.

Install two M4 Nuts and use small pieces of tape to cover the T-slots on the bottom of the Stepper Motor Mount to retain the Nuts.

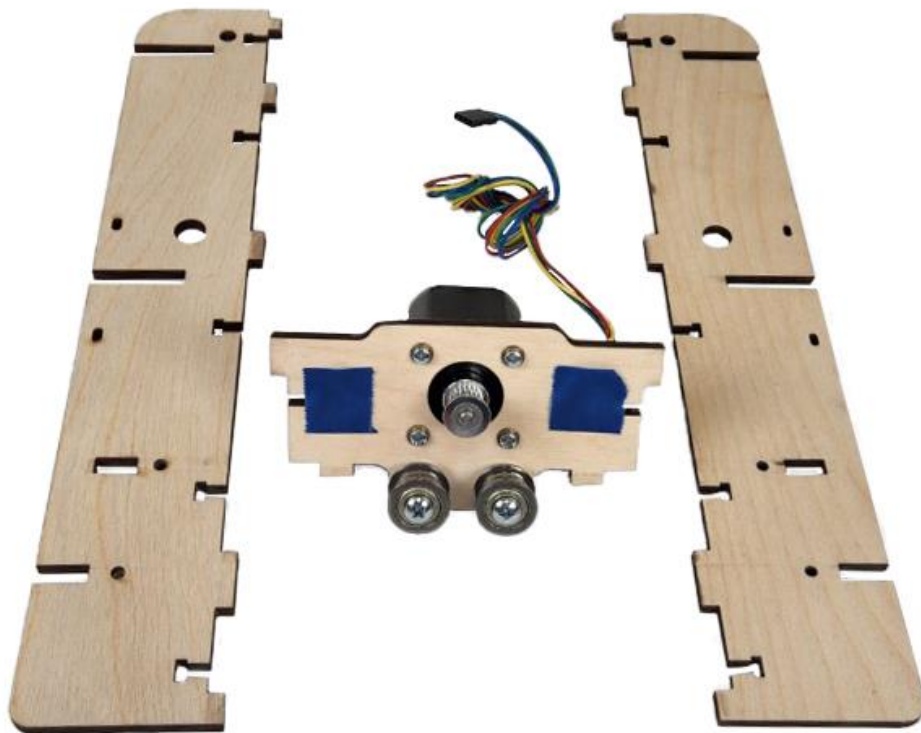

Step 1b Align the tab of the Stepper Motor Mount Assembly with the slot in the Gantry Side. Support and secure with one M4 x 16 Machine Screw.

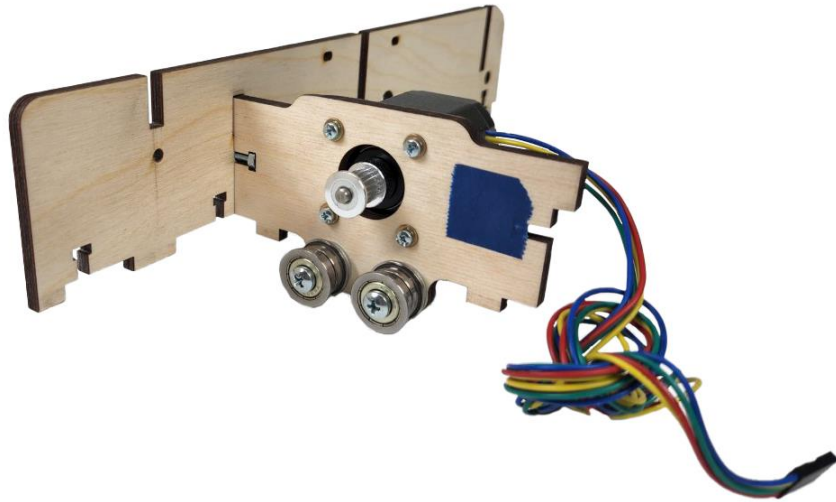

Repeat to install the other Gantry Side Support. Remove the tape after tightening.

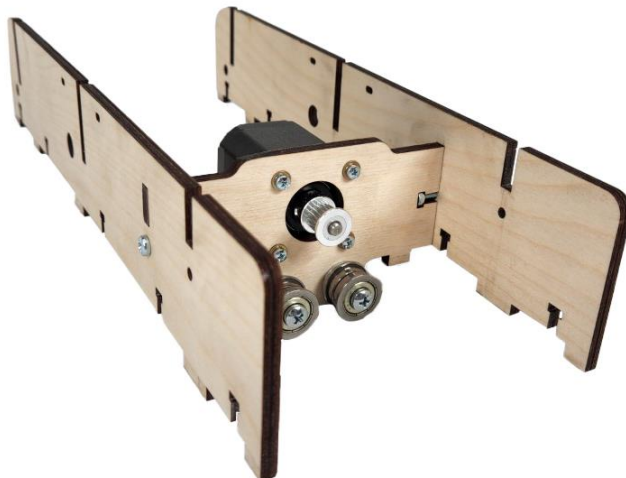

Step 1c Align the tabs of the Gantry Lower Side Brace (QG10) and slide them into the slots in the Assembly as shown. Secure with two M4 x 16 Machine Screws and Nuts.



Step 1d Carefully align the tabs of the Support Assembly and slide them into the slots in the Gantry Side (QG9). Secure with twelve M4 x 16 Machine Screws and Nuts.

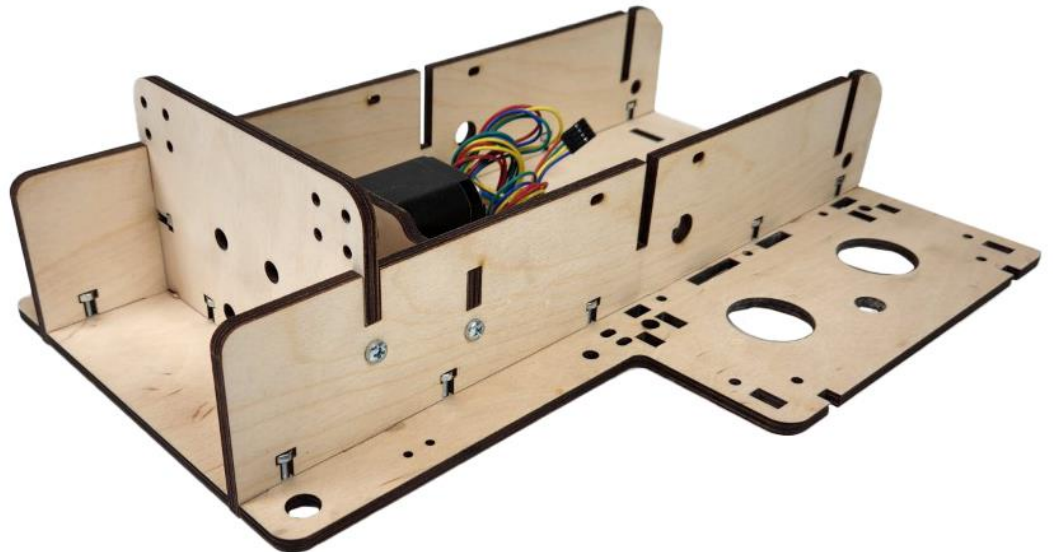
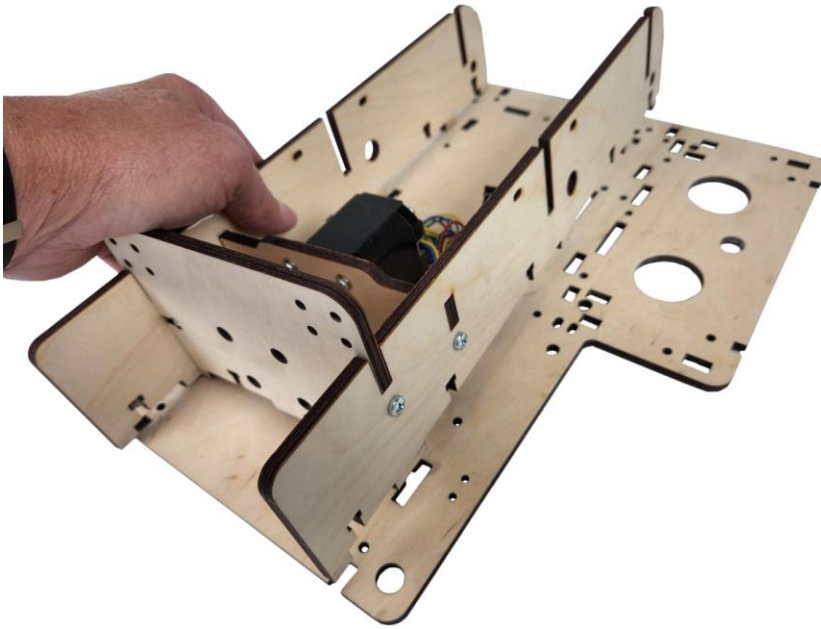

Step 1e Align the slots of the two Gantry Cross Braces (QG3) with the slots in the Gantry Side Assembly. Carefully insert the tabs in the corresponding slots and secure each with three M4 x 16 Machine Screws and Nuts.

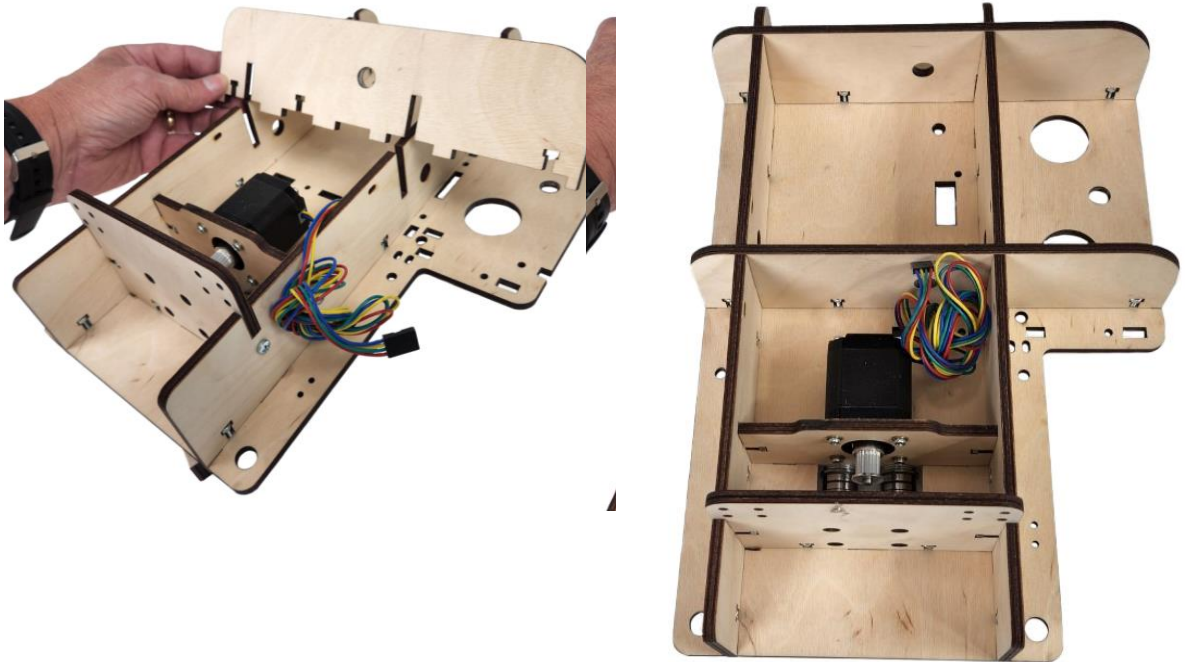

Repeat these steps to complete the other Gantry Side Support Assembly.

When completed Assembly are a mirrored copy of the other. It is essential that the Stepper Motor wires are oriented as shown above.



Step 2 Building the Gantry Back Assembly.

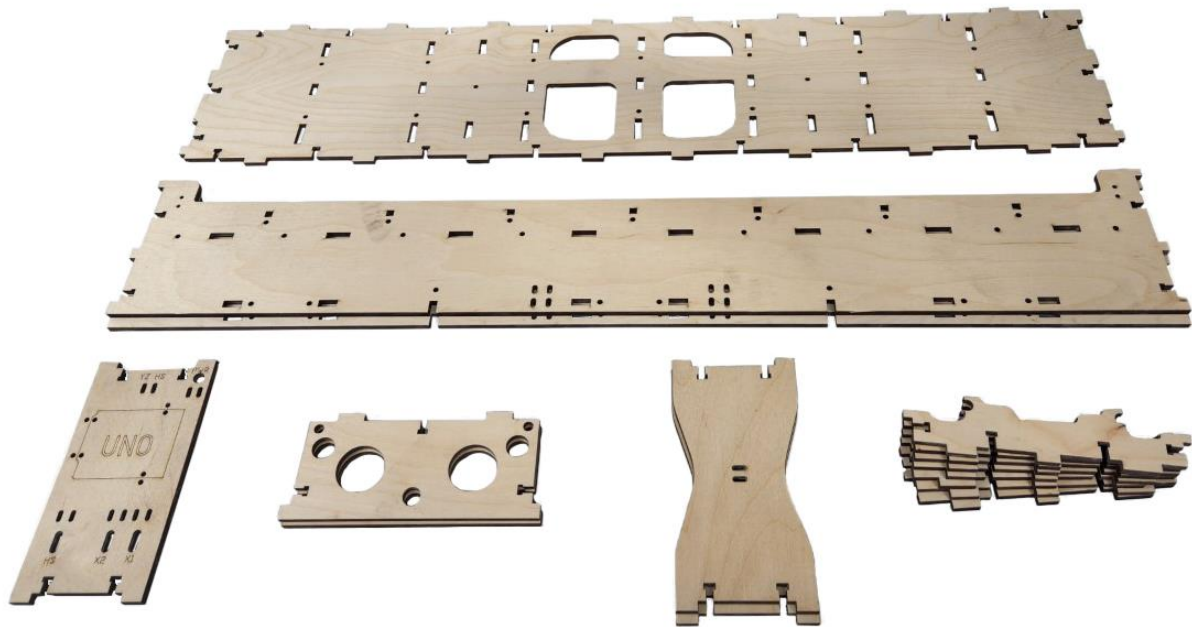

NOTE: The two small rectangular cutouts in the Gantry Frame (QG1) indicate the top of the Gantry Frame.

Step 2a Attach the seven Y Rail Supports (QG4) to the Gantry Frame (QG1) and secure each with two M4 x 16 Machine Screws and Nuts as shown below.



Step 2b Align the tabs and slots of the Gantry Bottom Brace (QG8) with the Gantry Assembly. Secure with fifteen M4 x 16 Machine Screws and Nuts.



Step 2c Insert the tabs of the two Gantry Back Supports (QG7) into the slots in the Gantry Assembly as shown below. Secure each with two M4 x 16 Machine Screws and Nuts.



Step 2d Insert the tabs of the Controller Mount (QG5) into the slots in the Gantry Assembly as shown below and secure in place with two M4 x 16 Machine Screws and Nuts

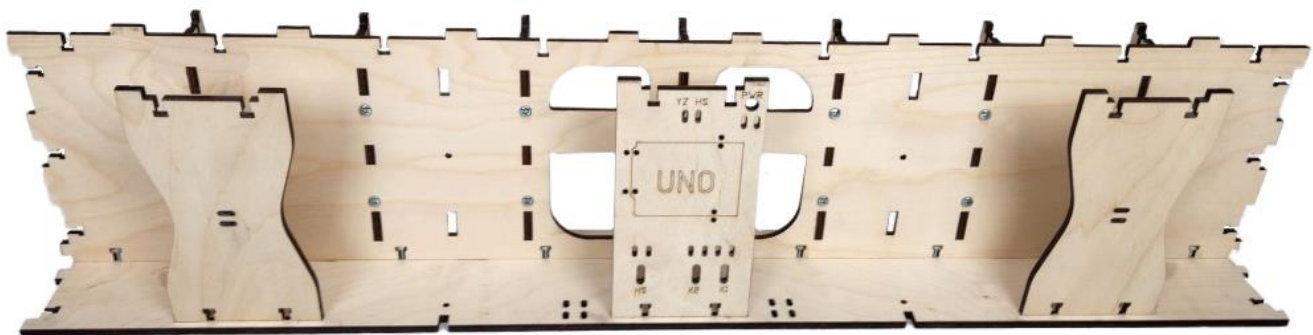

Step 2e Align the tabs of the Gantry Assembly with the slots in the Gantry Top (QG8). Carefully fit the top in place and secure with twenty-one M4 x 16 Machine Screws and Nuts as shown.



Step 2f Align and insert the tabs of the two Gantry Back Braces (QG6) into the slots of the Gantry Assembly and secure each with three M4 x 16 Machine Screws and Nuts as shown. Repeat to install both braces.





Step 2g Align and fit the tabs of the Gantry Assembly into the slots of the left Gantry Side Assembly and secure with seven M4 x16 Machine Screws and Nuts



Step 2h Align and fit the tabs of the Gantry Assembly into the slots of the right Gantry Side Assembly and secure with seven M4 x 16 Machine Screws and Nuts. (Completed Assembly below).



Step 3 Attaching the X1, X2, and Y Home Switches.

Step 3a Take the three (CB19) Home Switches and label the DuPont Connectors "X1", "X2" and "Y".

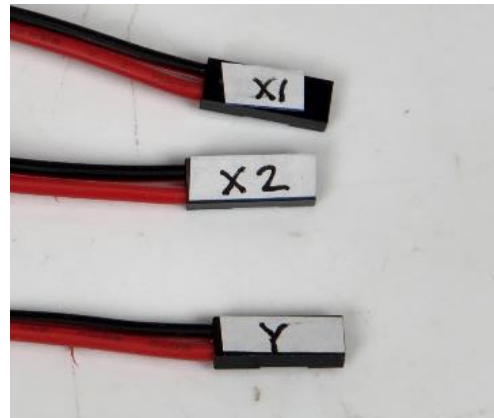

With the Gantry Assembly laying, as shown, attach the X1 Home Switch. Secure in place with two M 2.5 X 16 Machine Screws (H27) and M2.5 Lock Nuts (H43). Orient the Screw Head so that it tightens against the Switch housing.

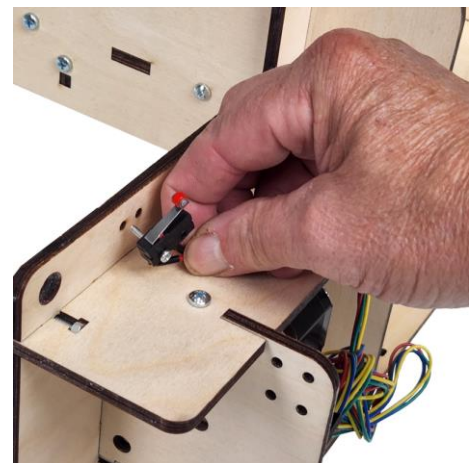

Route the X1 Home Switch wire from the mounting position up and through the hole in the Gantry Side Assembly, across the Gantry Assembly, and through the Controller Mount as shown.



Secure with a Zip Tie. Trim excess material after securing. Route the Home Switch Wire across the Gantry Assembly and through the Controller Mount as shown.

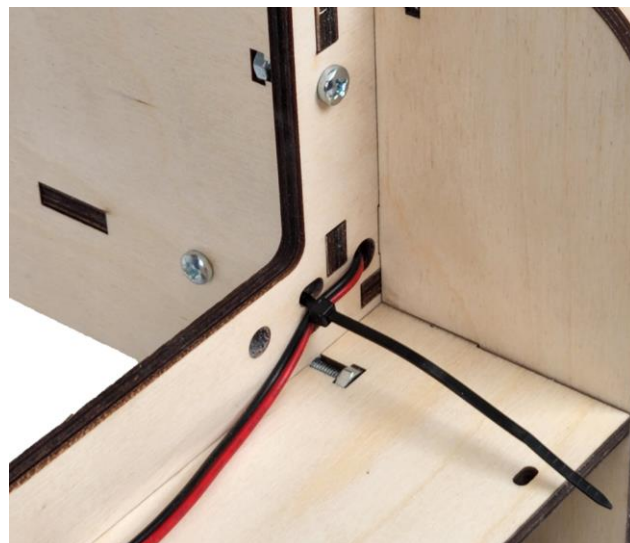

Follow the same procedure to install X2 Home Switch on the opposite side, as shown below.



Step 3b The "Y" Home Switch is located on the top left front side of the Gantry Assembly as shown.



Before installing the “Y” Home Switch, route the Home Switch wire through the rectangular opening in the upper front left corner as shown.

Run the wire through the small hole in the top of the Gantry Side Assembly and through the (QG2) Gantry Side Support.

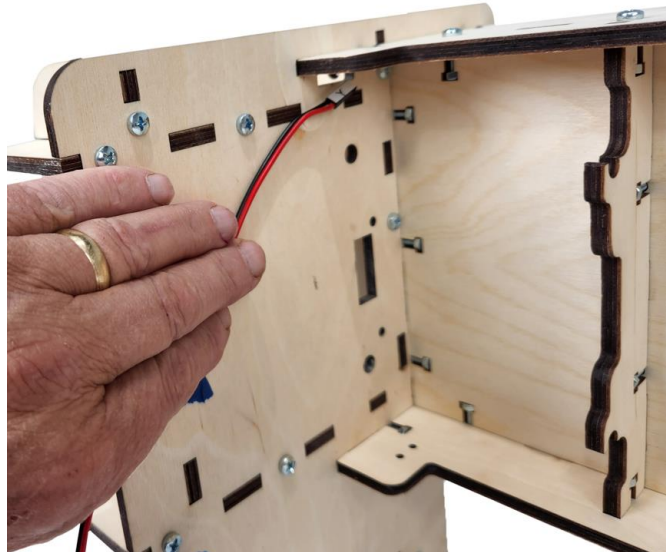

Run the wire back through the top of the Gantry Side Support and then through the small hole, then through the second, round hole so that the wire connector is on the inside of the Gantry Assembly and through the “HS” opening in the Controller Mount as shown.

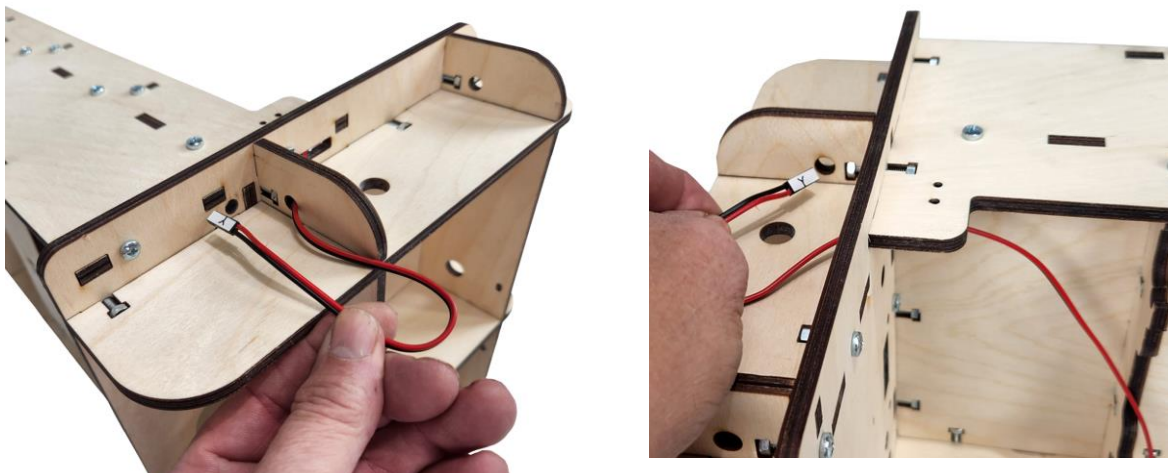



Step 3c Install the “Y” Home Switch beneath the Gantry Top Brace and secure with two M2.5 X16 Machine Screws and Lock Nuts.



Step 4 Routing the X1 and X2 Stepper Motor Wire to the Controller Support.

Step 4a Take the DuPont Connector for the X1 Stepper Motor (right side when viewed from the back) and run it up and through the three holes in the Gantry Side Assembly as shown.



Route the X1 Stepper Motor wire across the inside of the Gantry Assembly and through the Gantry Back Brace. After running the connector and wire through the X1 opening at the bottom of the Controller Mount use a small zip tie and secure the wire to the Gantry Back Support as shown.

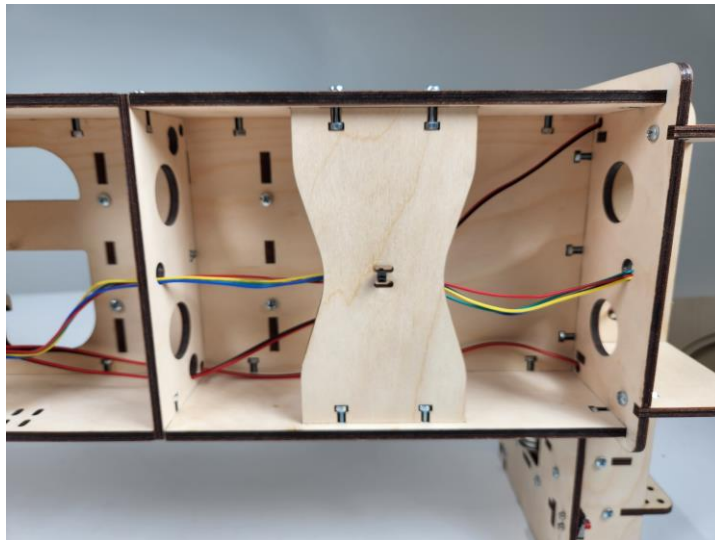

Step 4b Repeat the process to route the X2 Stepper Motor Wires.

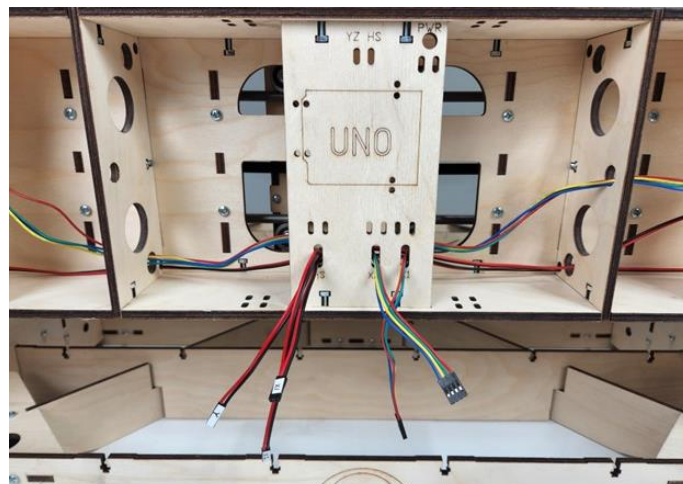

Step 5

Install the two Upper SG20U Bearing Assemblies for the Gantry Side Frame Assembly. The assembly order for the Upper Bearing Mounts: M6 x 35 Machine Screw (H95), SG20U Bearing (H44) (with hub facing toward the Bearing Fender Washer), Bearing Fender Washer (H42), Plywood, Bearing Fender Washer (H42) secured with a M6 Lock Nut (H18) as shown.



Step 6

Attach the upper SG20U Bearing Assembly to each of the Gantry Side Assemblies

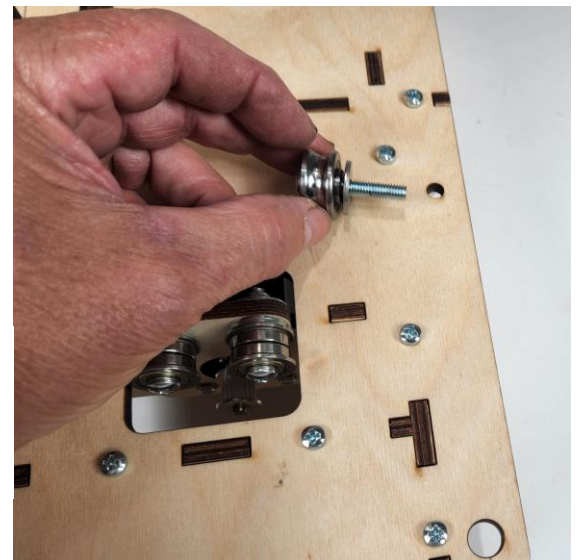
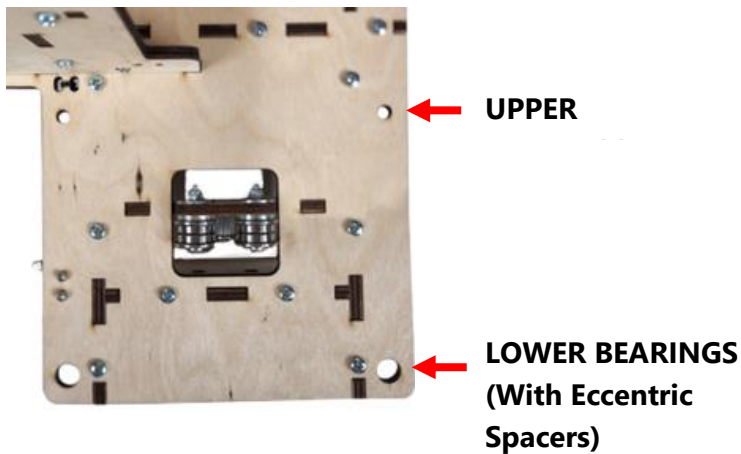

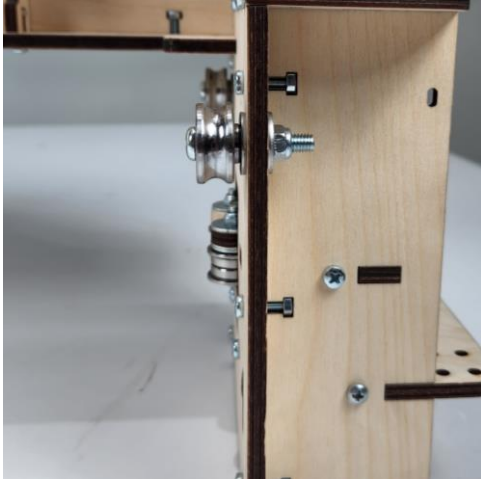

Step 7 Attaching the Gantry Assembly to the X Frame Assembly.

Notice the cutouts in the X Frame Side Supports.

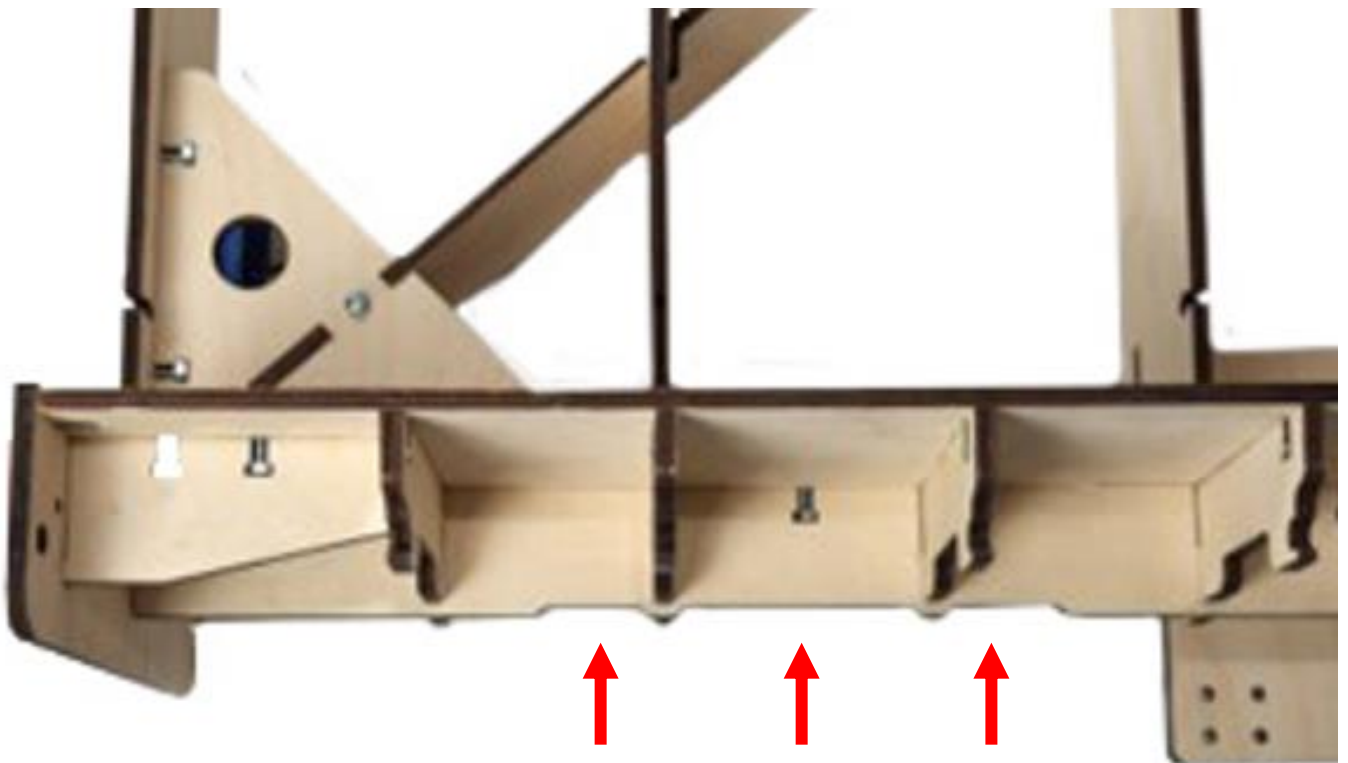

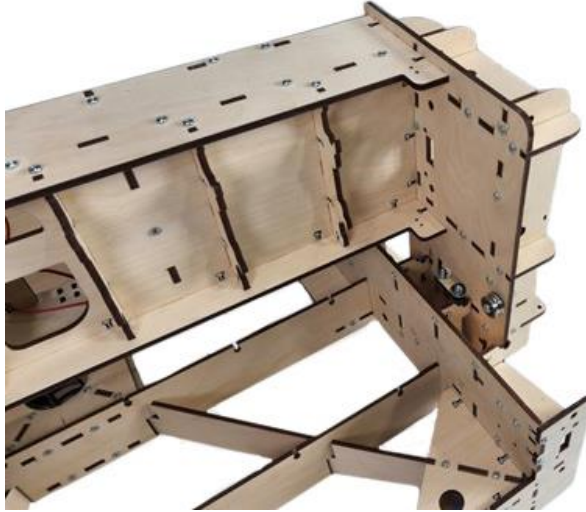

Notice that the Idler Bearings of the X1 Stepper Motor fit between the rail supports.

Step 7a Insert the Gantry Frame Assembly onto the X Frame Assembly.

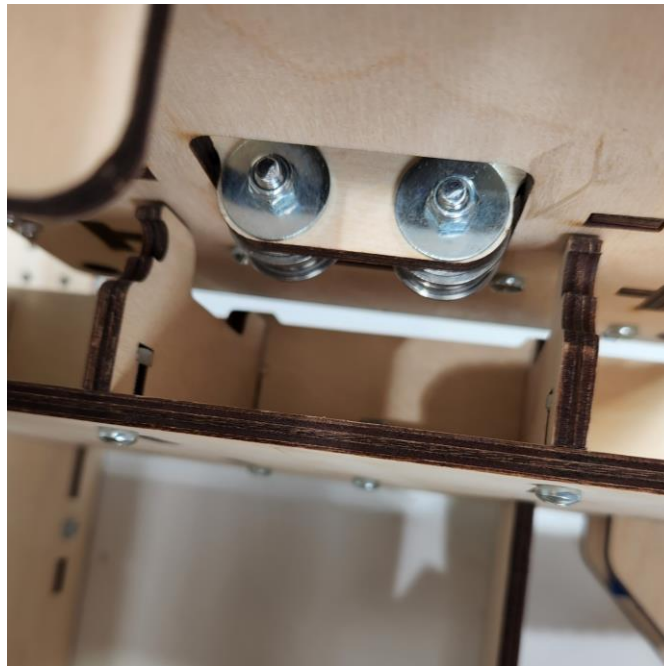

Step 7b

Insert the Rails (H99) into and through the upper holes in the X Frame End and supports, as shown.



Lift the Gantry Assembly so that the rail slides beneath both top Bearings. Insert the Rail completely, so that the ends of the Rail are seated flush in the Front and Back End Supports.



Repeat to Insert the bottom Rails completely, so that the ends of the Rails are seated flush in the Front and Back End Supports.

Step 8 Inserting the Lower Eccentric Bearing Assemblies into the Gantry Sides.

Step 8a Install the two lower SG20U Bearings for the Gantry Assembly as shown. The assembly order for the Lower Bearings: M6 x 35 Machine Screw (H95), SG20U Bearing (H44) hub facing toward the Bearing Fender Washer, Bearing Fender Washer (H42), Plywood, Eccentric Washer (H41), Eccentric Spacer (H40) secured with a M6 Lock Nut (H18).

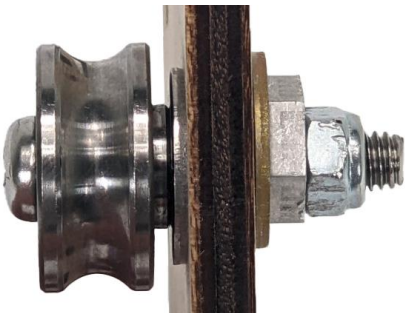

Slide the SG20U Bearing and Bearing Fender Washer on to the Machine Screw and insert the Machine Screw through the Rail side.



Step 8b Slide the Eccentric Washer and Eccentric Spacer on the Machine Screw and secure with a M6 Lock Nut.



Insert a Phillips screwdriver through the access hole in the bottom of the Frame Support and using a 10mm socket, snug the Locknut firmly against the face of the Eccentric Spacer and repeat to install all four Eccentric Bearing Assemblies.

Step 9

Adjust the Eccentric Spacers until the SG20U Bearings are snug against the Rails.

Rotate Clockwise

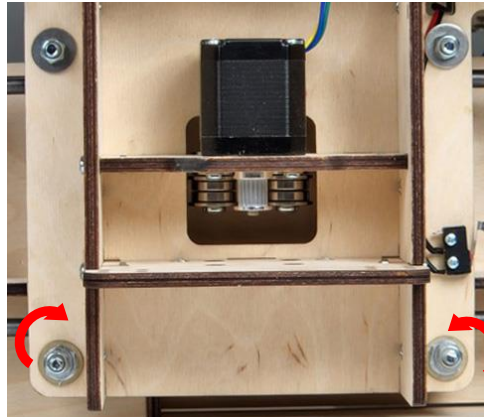

Rotate Counter-Clockwise

When adjusted, the position of the right and left Eccentric Spacers should mirror each other.



The SG20U Bearings should be snug against the Rail. Use your finger to roll the Bearing. It should not spin in place.

When the SG20 Bearings are properly adjusted against the Rail, the entire Gantry Assembly should move as you roll the Bearing. Make sure the Gantry Assembly rides smoothly along the full length of the Rails. Make adjustments as required.

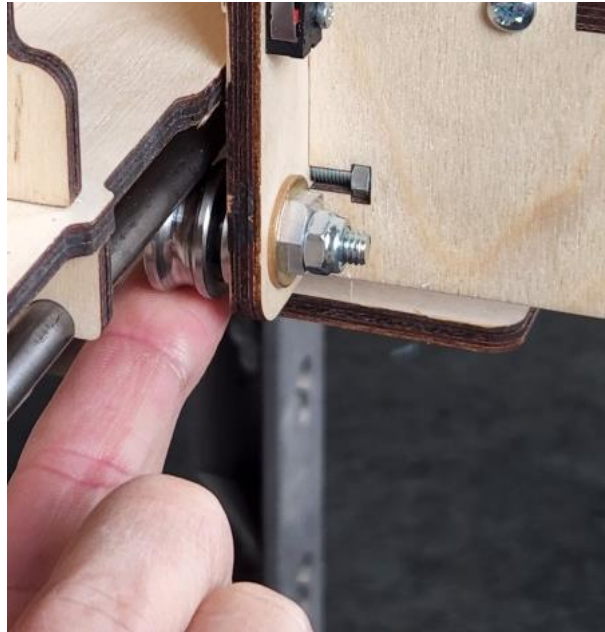





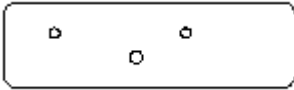
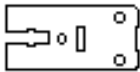

Final Assembly

Required Wood Components

Part #	Description	Qty	Photo
QR1	XY Rail Stop	6	
QR3	XY Belt Retainer	12	

Required Hardware

Part #	Description	Qty	Photo
H53	Stress Proof Steel XY-Rail (XX")	2	
H14	M4 x 16 Machine Screw	18	
H98	M4 x 20 Machine Screw	12	
H47	M4 lock Nut	12	
H15	M4 Nut	18	
H48	M5 x 30 Machine Screw	6	
H93	M5 Square Nut	6	

H50	Idler Fender Washer	6	
R2	Makita Router	1	
H83	GT2 – 9mm Belt	3	
CB12	Power Supply with Cord	1	
H26	Small Zip Tie	30	
CB16	Controller	1	

Illustrated Step by Step Instructions

- Step 1** Attach four X Rail Stops (QR1) on the front and back Frame End Supports and secure each with two M4 x 20 Machine Screws and Lock Nuts as shown.

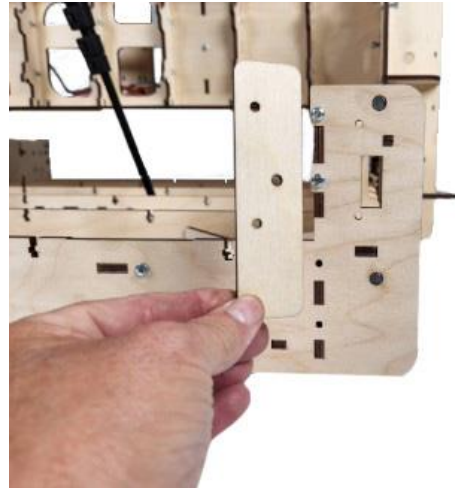

Make sure the hole located between the Machine Screws in the Rail Stop is clearly visible through the rectangular opening in the Frame End Support



Step 2 Attaching the Y Carriage to the Gantry Assembly.

Step 2a Insert the upper Rail through the Gantry Side Assembly. Rotate the Rail as it passes through Gantry Rail Supports and is fully seated in the opposite Gantry Side Assembly.

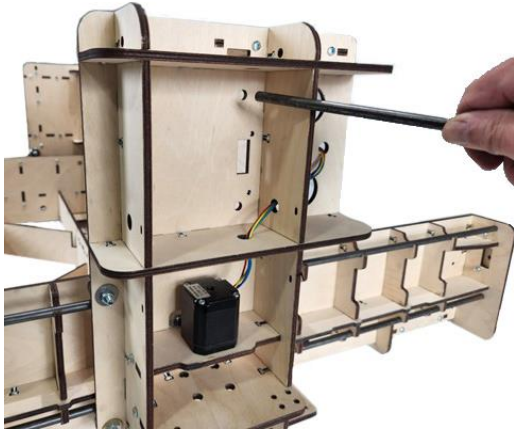

Step 2b Insert the lower Rail through the Gantry Side Assembly, across the Rail Supports but only partially across the Gantry Assembly. Next, hang the upper SG20U Bearings of the Y Carriage Assembly on the Upper Rail. Then finish threading the Rail across the top of both Lower SG20U Bearings on the Y Carriage Assembly, through the remaining Rail supports and seat the Rail in the opposite Gantry Side Assembly.

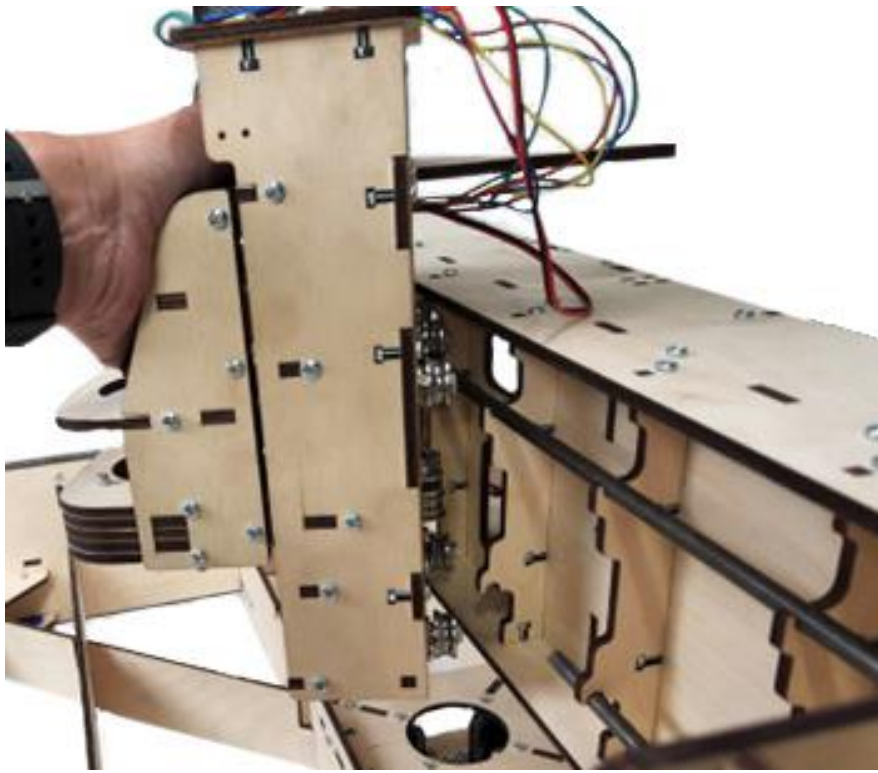

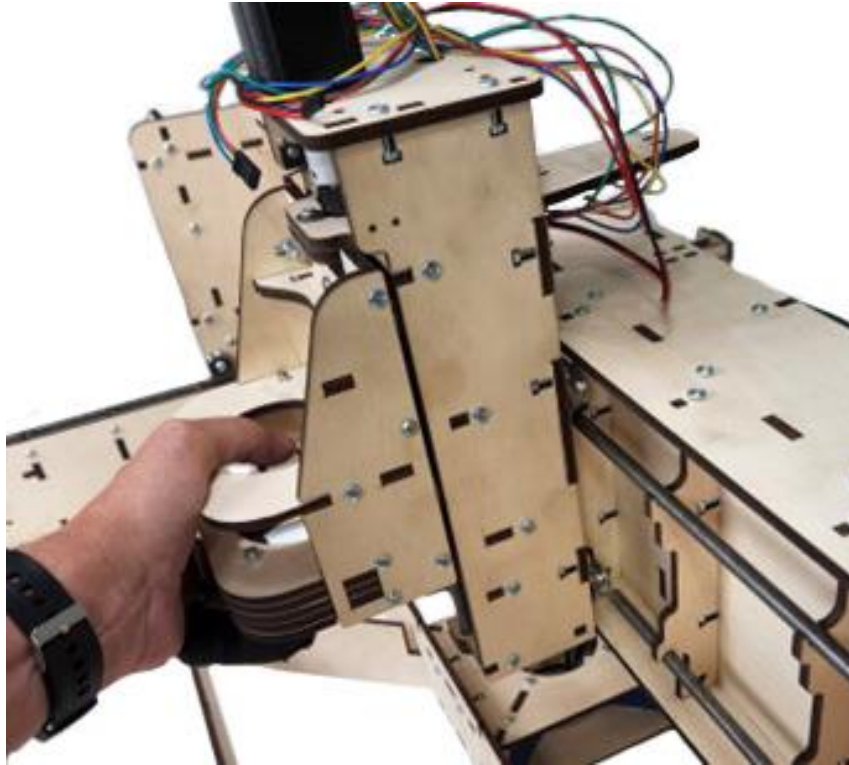

Step 2c Adjust the Eccentric Spacers until the SG20U Bearings are snug against the rails

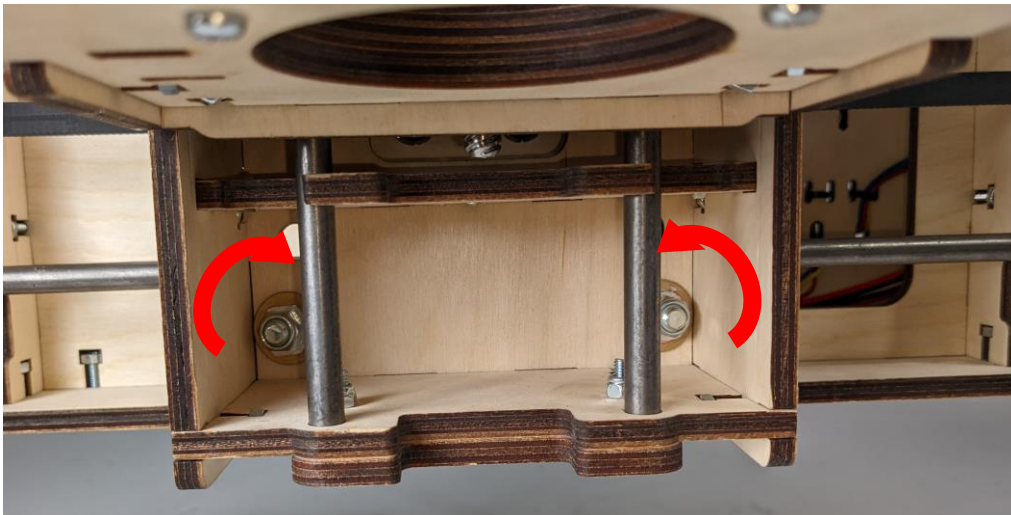

Rotate Clockwise

Rotate Counter-Clockwise



The SG20U Bearing should be snug against the rail. Use your finger to roll the bearing. It should not spin in place. When the bearing is properly adjusted against the rail the entire Y Carriage Assembly should move as you roll the bearing. Make sure the Y Carriage rides smoothly along the full length of the rails.

Adjust as required.





There are four (QR3) XY Belt retainers used for each of the 3 sets of the GT2 9mm Belt Assemblies.

Step 3 Attaching the GT2 9mm Belts.

Step 3a Cut two lengths of the GT2 9mm Belt **60 inches** long for the X axis and one to **34 inches** for the Y axis.

Step 3b With the teeth of the GT2 Belt facing down, thread one end of the GT2 Belt through the rectangular slot in a Belt Retainer.



Step 3c Cover the Belt with the teeth still facing down with the second Belt Retainer.



Step 3d Sandwich the GT2 Belt between the two Belt Retainers and bolt them together with three M4 x 16 Machine Screws and Nuts.



After installing the first Screw and Nut, it is possible to adjust the amount of GT2 belt installed through the bottom of the clamp by gently pulling the GT2 belt until only two or three of the teeth are visible. Then, insert the remaining two M4 x 16 Machine Screws and Nuts.

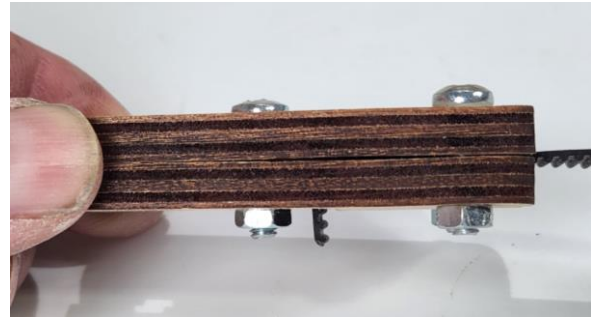
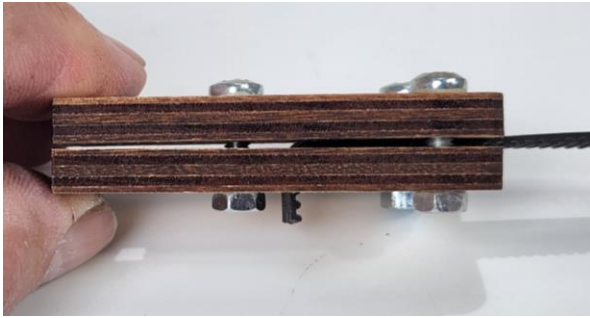

When properly installed and tight, there shouldn't be a visible gap between the two Belt Retainers.

Step 3e

Stretch the Belt Assembly out and measure the distance between the two notched ends in the Belt Retainers. The distance should be $57\frac{1}{4}$ inches for both X axis and $31\frac{1}{4}$ inches for the Y axis.



$57\frac{1}{4}$ inches X

$31\frac{1}{4}$ inches Y



Simply loosen the M4 x 16 Machine Screws and Nuts and gently adjust the GT2 belt to the correct length, as needed.

Step 3f

Insert a M5 x 30 Machine Screw (H48) with a Idler Fender Washer (H50) through the Rail Stop mounted on the front Frame End Support. Then thread a M5 Square Nut (H93) on the exposed threads. Repeat for the rear Frame End Support.



Step 3g

Slip a Belt Retainer Assembly end over the exposed thread so that the Square Nut is seated in the cutout of the Belt Retainer Assembly. Be sure the smooth side of the GT2 Belt is visible with the teeth oriented toward the X Frame Assembly.



Step 3h Tuck the other Belt Retainer Assembly between two Rail Supports as shown. Hold the GT2 Belt in the notch in the Rail Support and slide the Gantry Assembly past the Belt Retainer Assembly.

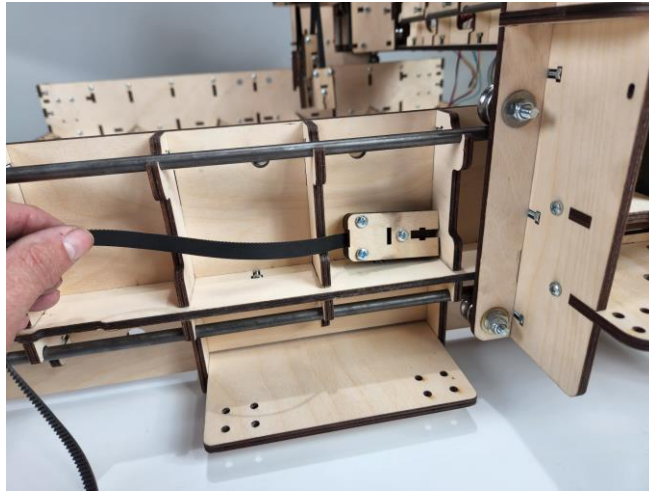

Step 3i Pull the slack GT2 belt tight and notice its location behind the GT2 Pulley and the Idler Pulleys. Gently position the GT2 Belt behind the Idler Pulleys. Using a long Allen wrench or a stiff piece of wire (e.g., AWG 12 solid core copper wire), bend a small hook into one end of the wire. Slip the short end behind the Belt and pull it between the Idler Pulleys and create a loop, as shown.

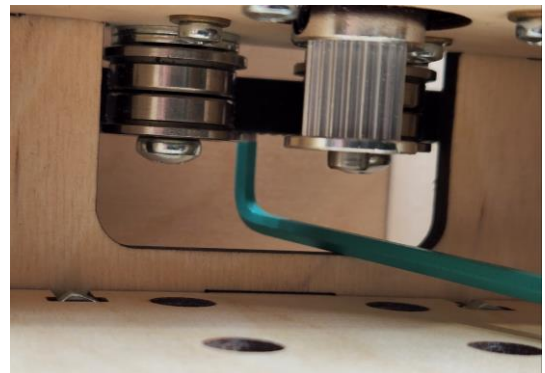

Slide the loop in the GT2 Belt over the GT2 Pulley, keeping tension on the belts so they do not slip off the Idler Pulleys.



Step 3j Slip a Belt Retainer Assembly end over the exposed thread so that the Square Nut is seated in the cutout of the Belt Retainer Assembly on the opposite side as shown. Tighten the M5 screws so that the GT2 belt is snug. **Do not over tighten and stretch the belt.**

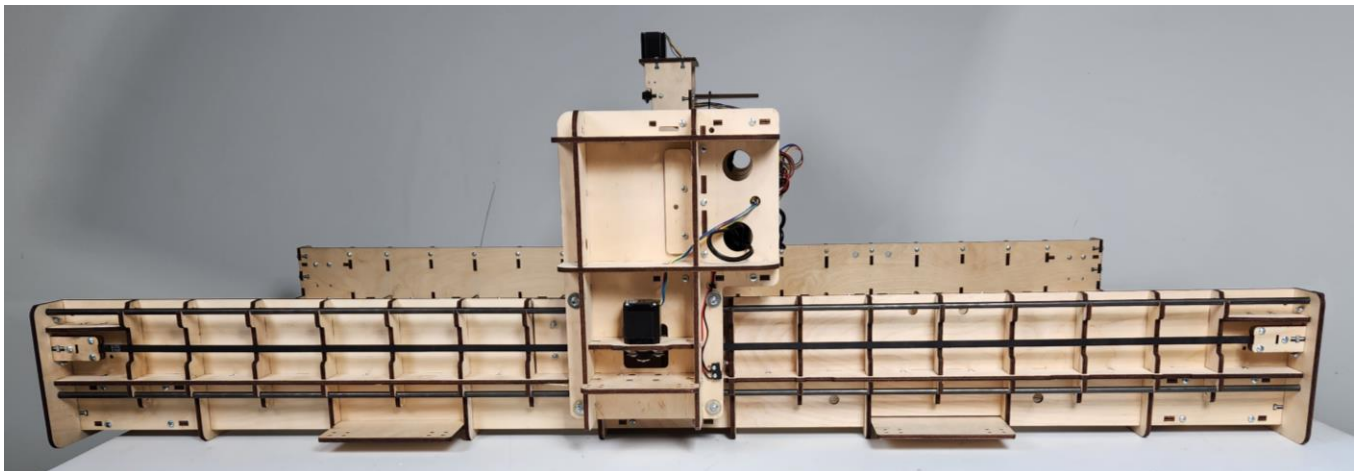

Step 4 Repeat these same steps to install the X2 GT2 Belt on the opposite side.

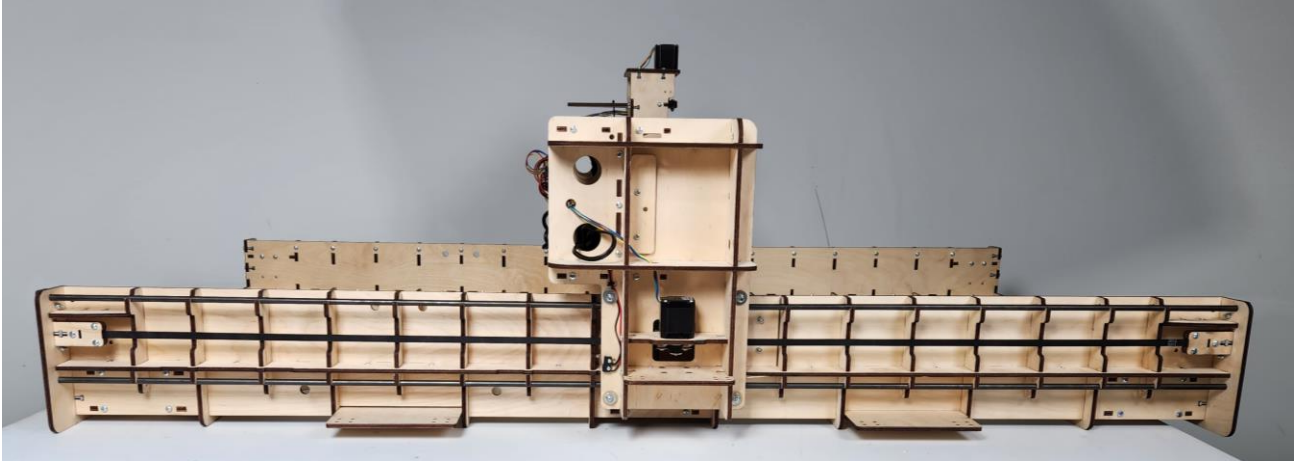

Step 5 Installing the Y Axis GT2 Belt.

Step 5a Install the Rail Stops (QR1) and secure with two M4 x 20 Machine Screws and Locknuts for each side of the Gantry Assembly.

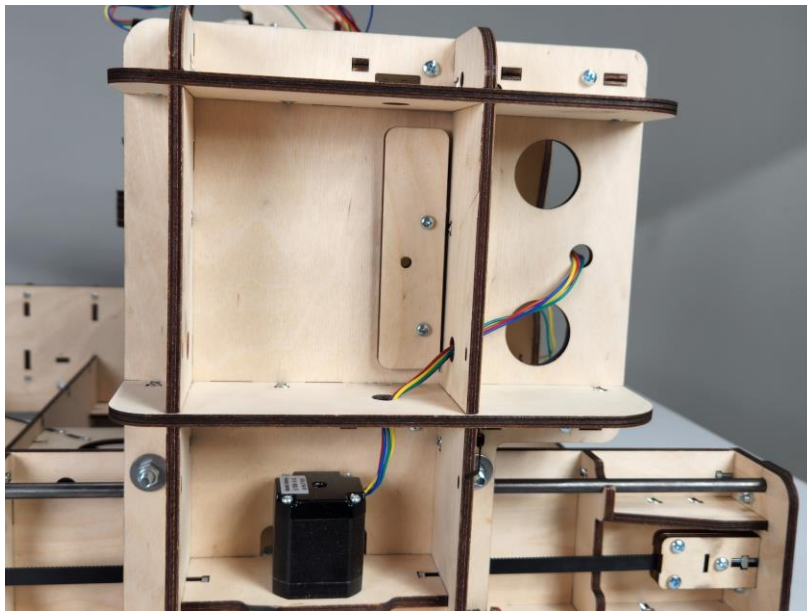

Step 5b Insert a M5 x 30 Machine Screw with Idler Fender Washer (H50), through the Rail Stop and thread a M5 Square Nut on the exposed threads. Repeat for other Gantry Side Assembly.

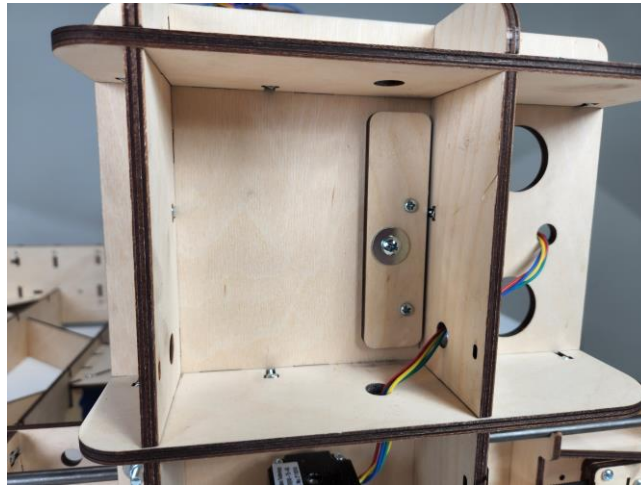

Step 5c Slip the Belt Retainer Assembly end over the exposed thread so that the Square Nut is seated in the cutout in the Belt Retainer Assembly. Be sure the smooth side of the GT2 Belt is visible with the teeth oriented toward the Gantry Assembly.



Step 5d Temporarily place the Belt Retainer Assembly through the large opening in the Gantry Assembly as shown.

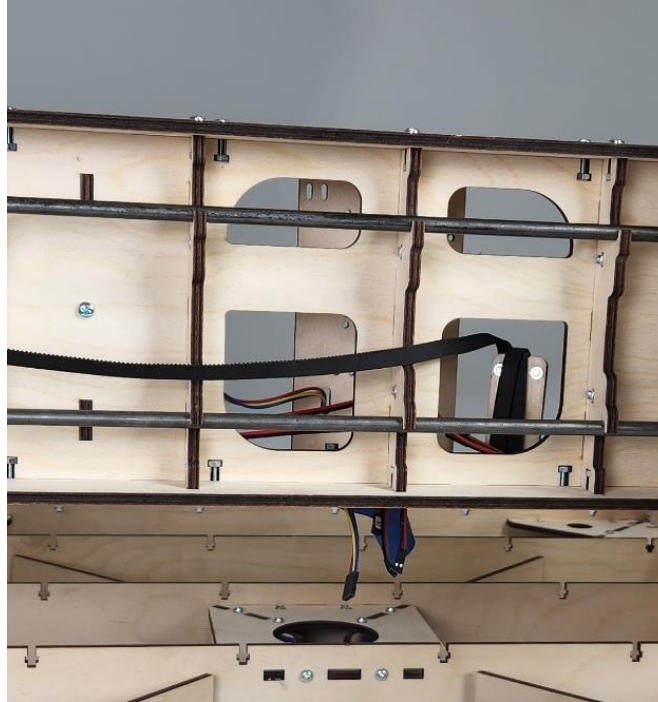

Step 5e

Slide the Y Carriage Assembly past the Belt Retainer Assembly. Position the Y Carriage Assembly so that it is immediately in front of one of the large openings in the Gantry Frame. Align the rectangular opening in the Z Frame Assembly with the opening in the Gantry Frame by manually turning the Helical Coupler at the top of the Y Carriage Assembly to lower the Z Frame Assembly.

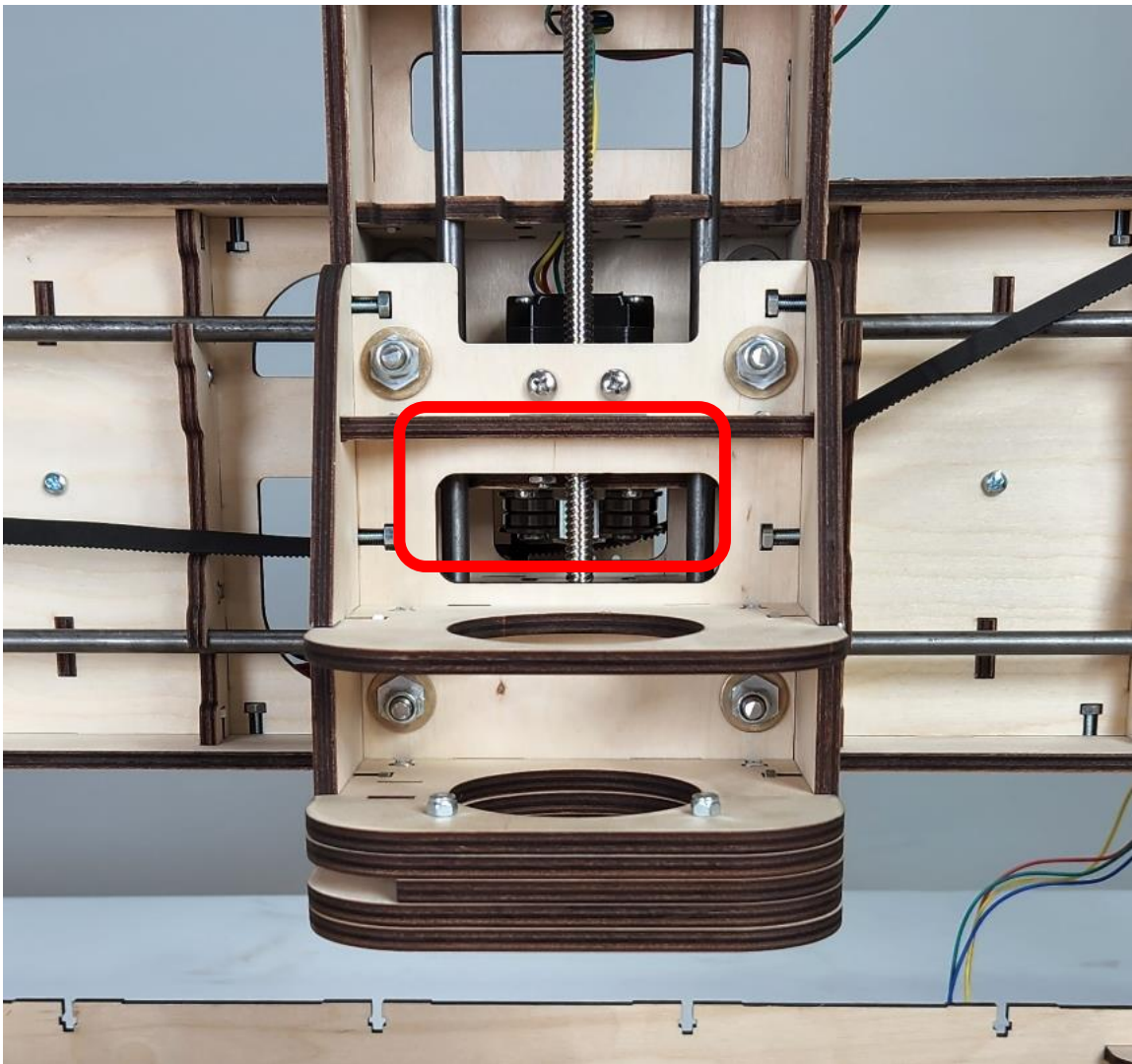

Step 5f Position the GT2 Belt so that it run across the two Idler Pulleys.



Back View

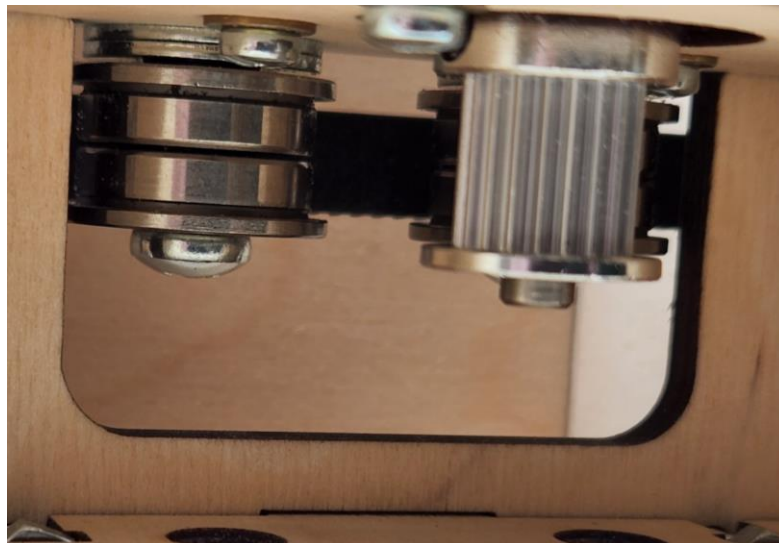

Front View

Step 5g

Using a long Allen Wrench or a stiff piece of wire (e.g., AWG 12 solid core copper wire), bend a small hook into one end of the wire. Carefully insert the hook through the front of the Z Frame Assembly and hook the wire over the GT2 Belt as shown. Pull the GT2 Belt between the Idler Bearings and create a loop while keeping tension on the GT2 Belt so it doesn't slip off the Idler Bearings.

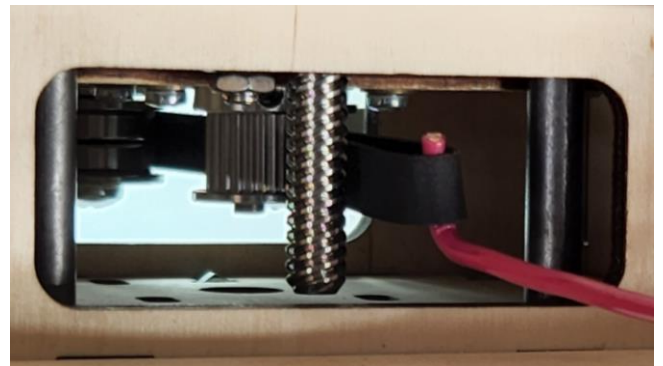
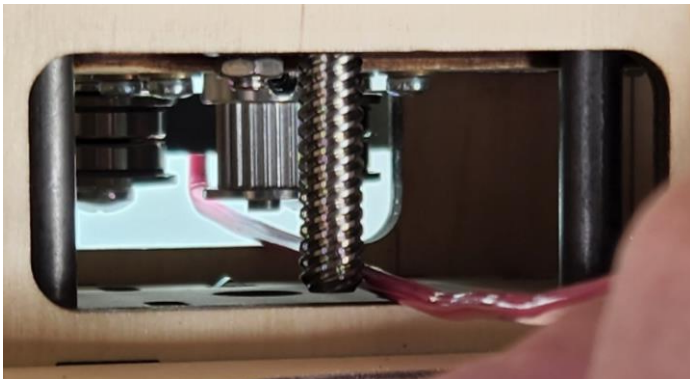

Front View

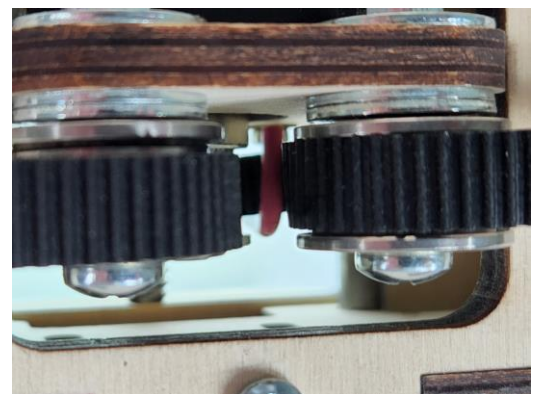

Back View

Step 5h Loop the GT2 Belt over the GT2 Pulley. Hold the Y Carriage Assembly in place and pull the GT2 Belt snug.

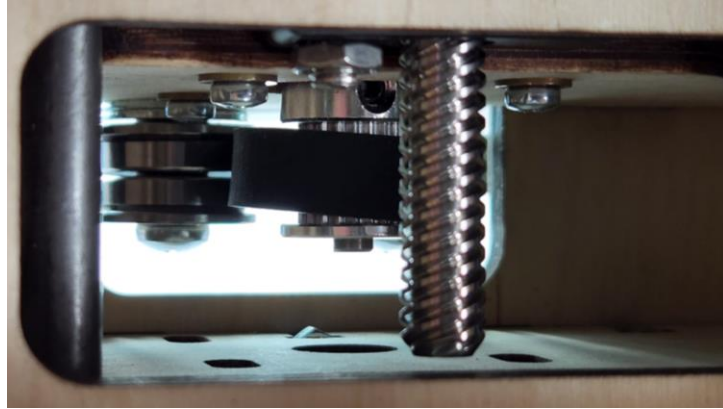

Step 5i Slip the Belt Retainer Assembly end over the exposed thread so that the Square Nut is seated in the cutout in the Belt Retainer Assembly and tighten the GT2 Belt to remove any slack. **Do not over tighten and stretch the belt.**



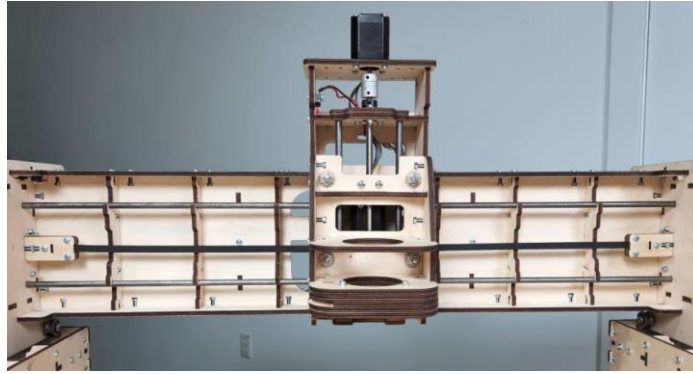

Step 6 Attaching the Controller to the Controller Support.

Step 6a Use four small Zip Ties to attach the Controller (CB16) to the Controller Support.

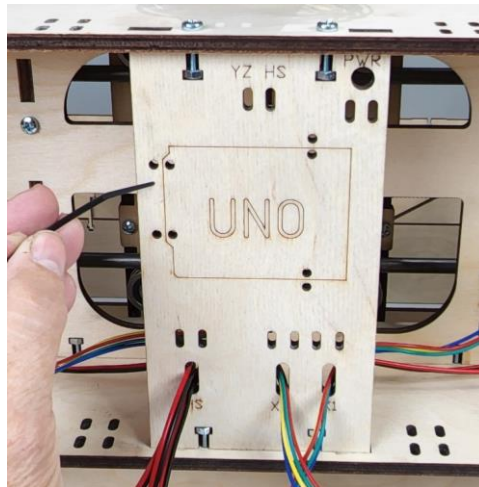

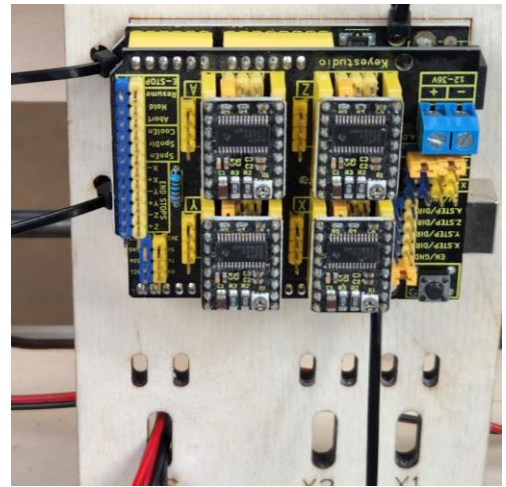
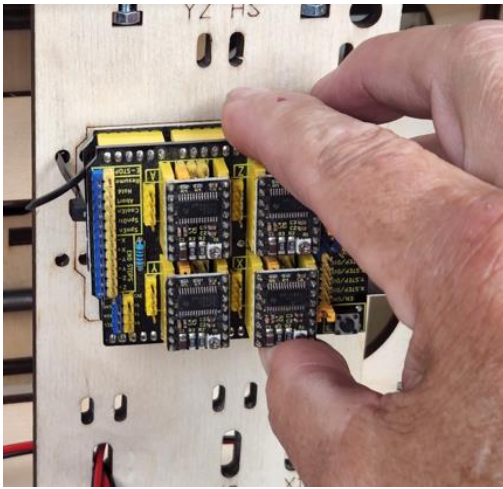

Step 6b Gently tighten the Small Zip Ties and then carefully trim the ends with scissors.



Step 7 Attaching the Power Supply.



Step 7a Thread the Power Supply cord behind the Gantry Back Support and through the large hole in the Gantry Back Brace as shown.

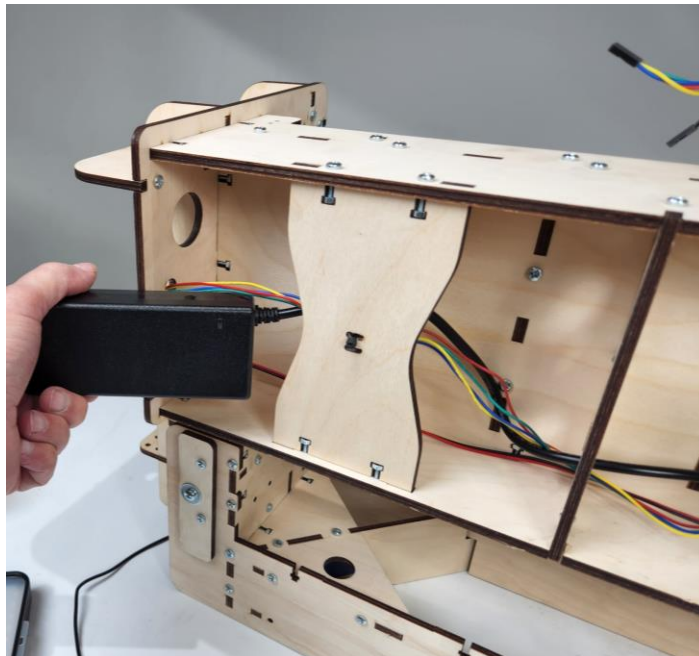

Step 7b Continue threading the Power Supply cord behind the Gantry Back Support and through the large hole in the Gantry Back Brace and past the Controller Support as shown.

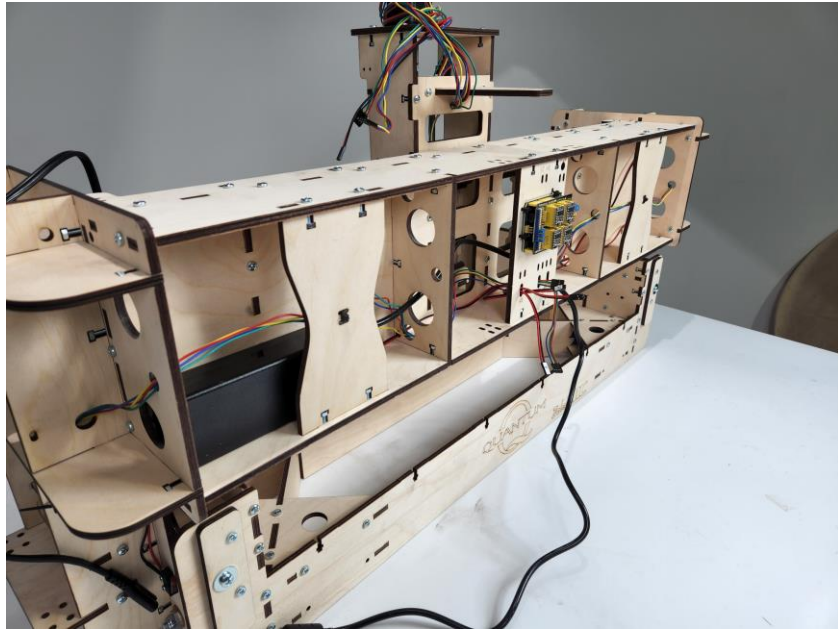

Step 7c Bundle the excess power cord and secure with a small Zip Tie.



Step 7d Thread the exposed Power cord end through the "PWR" hole in the Controller Support.

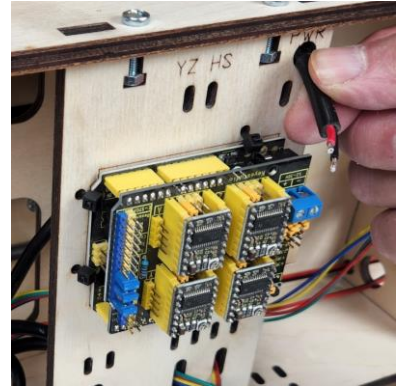

Step 7e **IMPORTANT** When connecting the Power Supply to the Controller, make sure the red wire is connected to the (+) positive terminal and the black wire is connected to the (-) terminal.

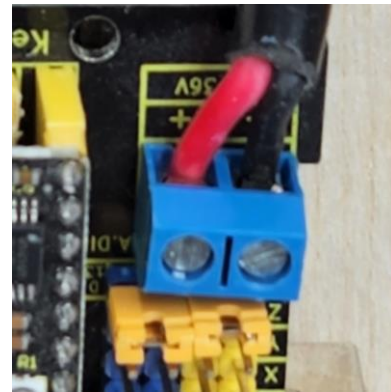

Step 7f Secure the Power cord wire to the Controller Support with a small Zip Tie.

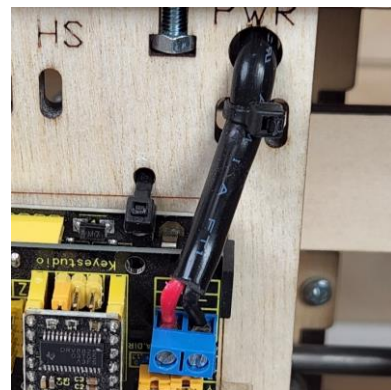

Step 7g Plug the Power cord into the Power supply.

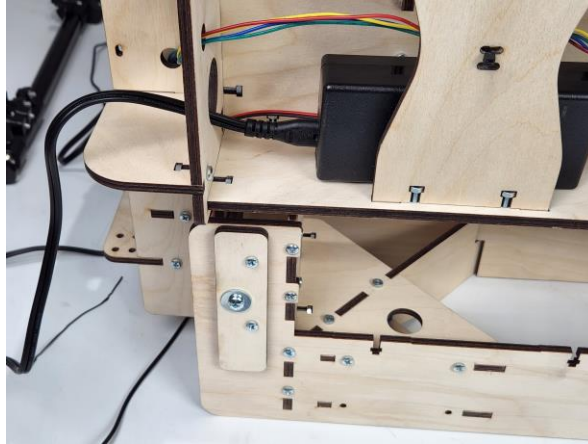

Step 8 Installing the Makita Router.

Step 8a Slip the Makita Router (R2) into the Router Mount.



Step 8b

Snug the Makita Router in place by tightening the Router Mount Clamp. Then tighten the two M4 x 35 Screws (H85) and Locknuts at the front of the Router Clamp

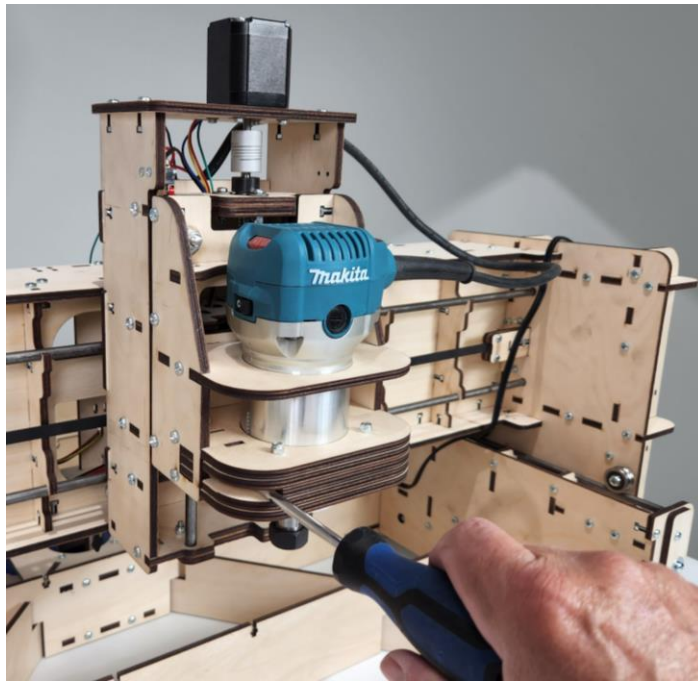

Step 9 Wire Management.



WARNING In order to reduce electrical noise which can interfere with the proper operation of the Stepper Motors and Controller, it is required that all the wiring and securing of loose wires be performed as illustrated in the manual. Failure to do so may result in poor machine performance.

- Step 9a** Make a loop of cord approximately six inches from the Makita Router to the midpoint of the loop. This will allow the Makita Router to travel up and down the Z Axis without stress to the Power Cord.

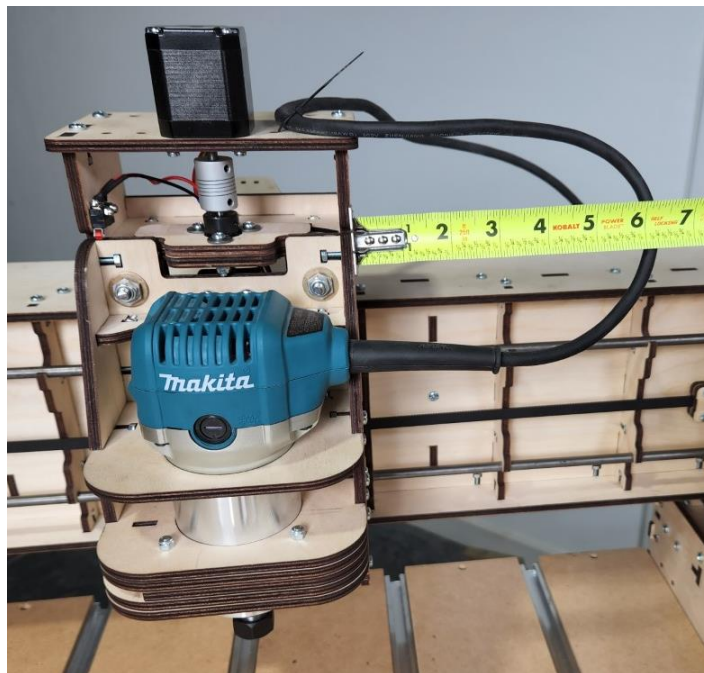

Step 9b Secure the Makita Router cord, the Y Home Switch, Y Stepper Motor and Z Stepper Motor wires across the bottom of the Carriage Top Support, as shown.

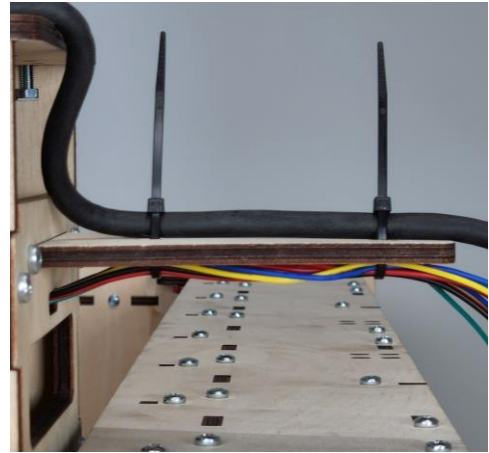
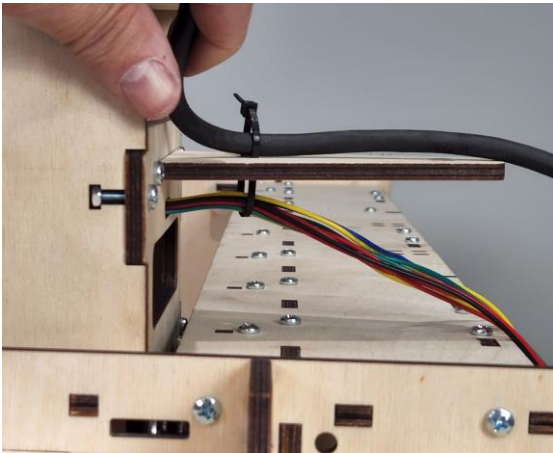

Step 9c Continue bundling the Stepper Motor and Home Switch wires together with small zip ties spaced 4 to 5 inches apart.



Bundle enough wire so that when the wires are attached to the Controller Mount, the Y Carriage Assembly can travel back and forth across the Gantry Assembly without pulling on the wires.

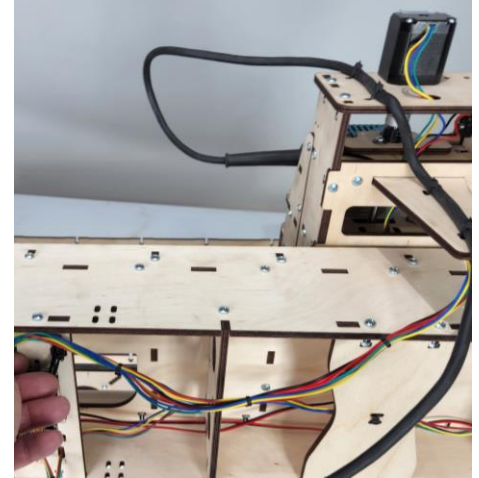
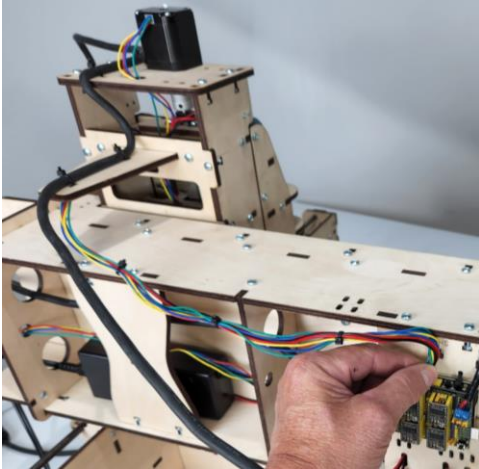

Secure the wires to the Controller. Mount with a Zip Tie to the "YZ HS" mounting holes.

Step 9d Route the Makita Router cord through the Gantry Back Brace and Gantry Side as shown.

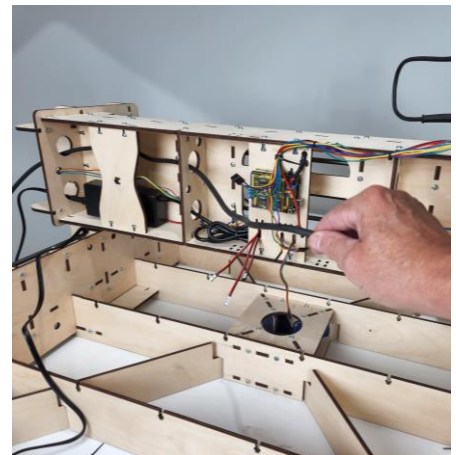

Step 9e

Holding the Makita Router cord at underside of the two elongated holes in the top of the Gantry Top Brace located just to the left of the Controller, measure enough cord to allow the Y Carriage Assembly to travel back and forth across the Gantry Assembly without pulling on the Router cord. In addition, leave a wide enough loop of cord so that it will not interfere with the Stepper and Home Switch wires.

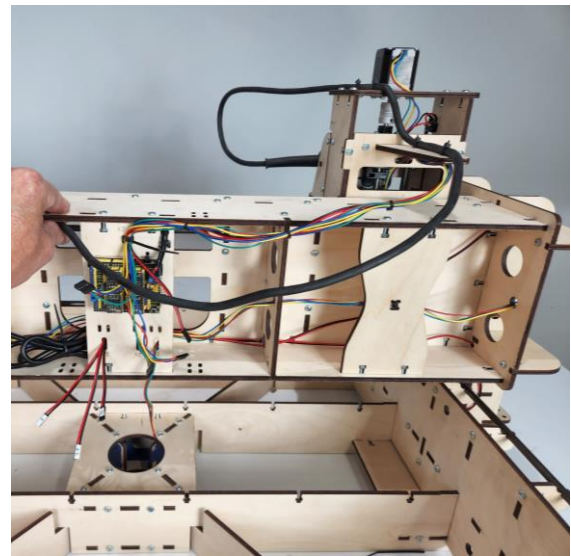
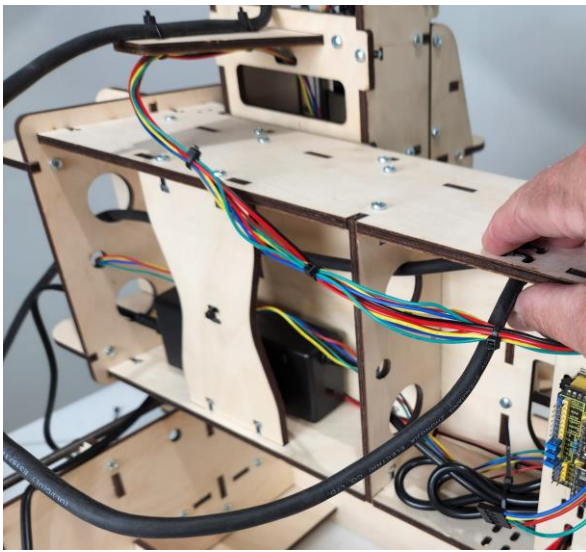

Step 9f

Secure the Makita Router Cord to the Gantry Top Brace with two small Zip Ties as shown.

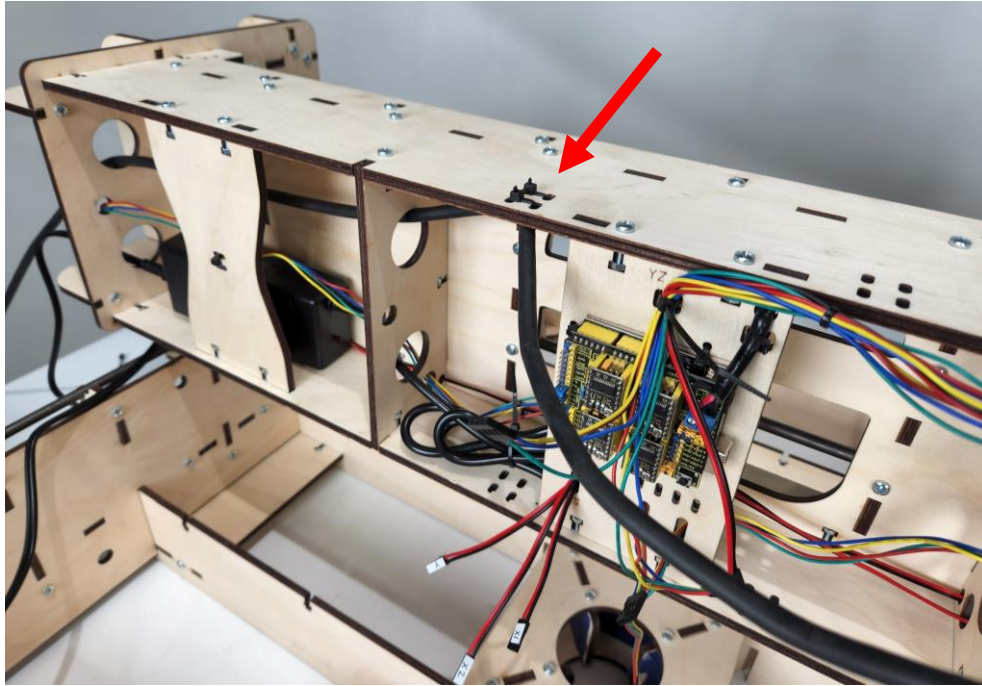

Step 10 Connecting the Home Switches to the Controller.

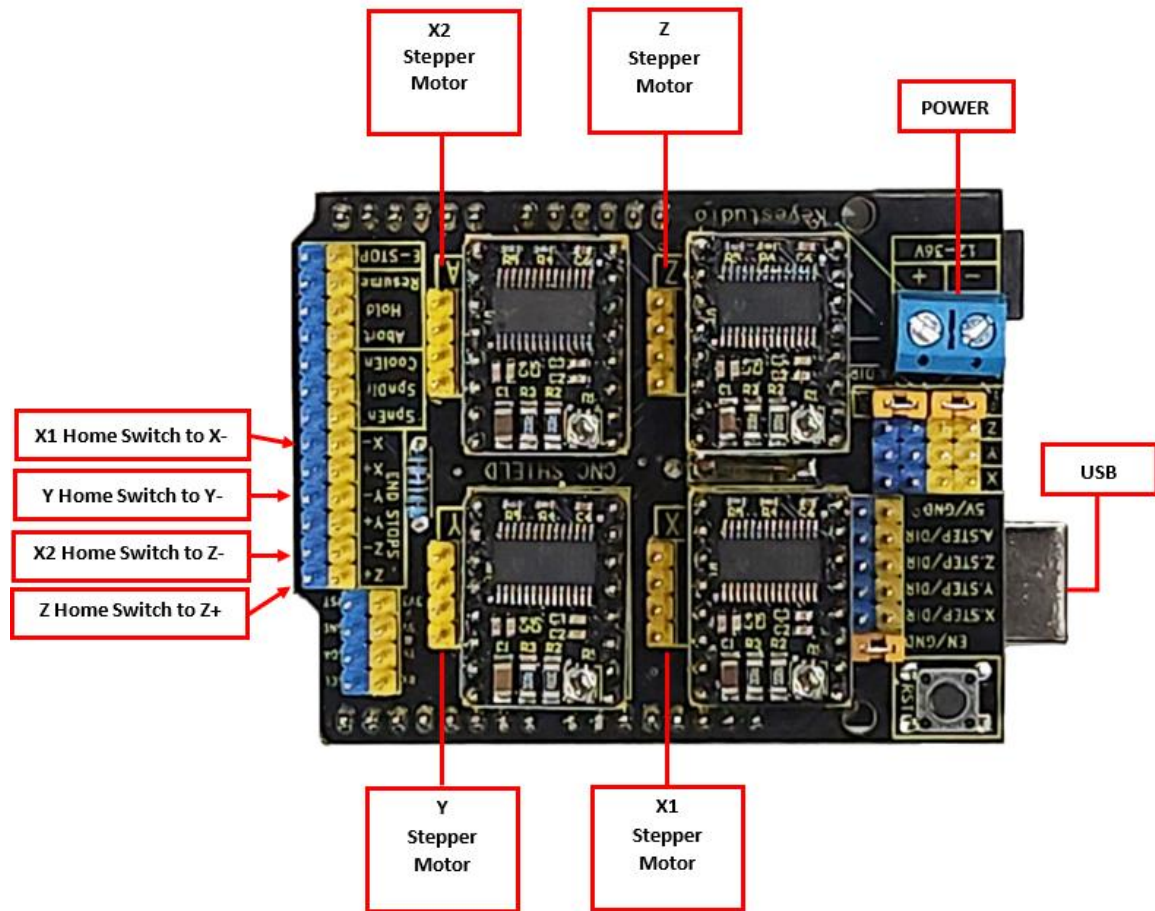

IMPORTANT. The Controller is mounted so that the PIN Designations are upside down. It is very important to be certain the Dupont Connectors at the end of the wires cover the proper pins on the controller. Use the diagram above for reference

Step 10a Connect the Z Home Switch to the Z+ plug on the Controller.

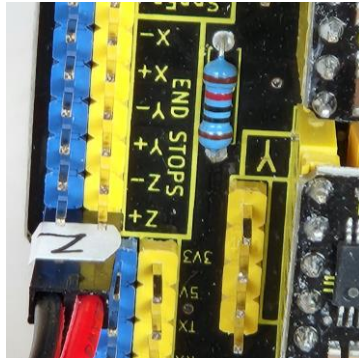

Step 10b Connect the X2 Home Switch to the Z- plug on the Controller.

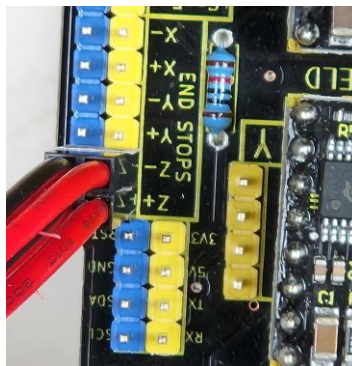

Step 10c Connect the Y Home Switch to the Y- plug on the Controller.

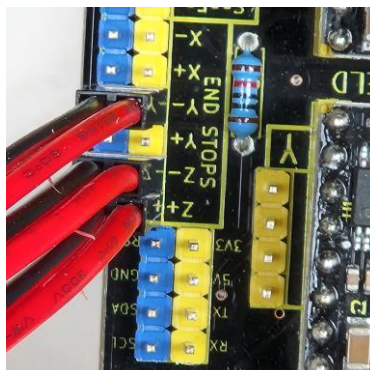

Step 10d Connect the X1 Home Switch to the X-
plug on the Controller

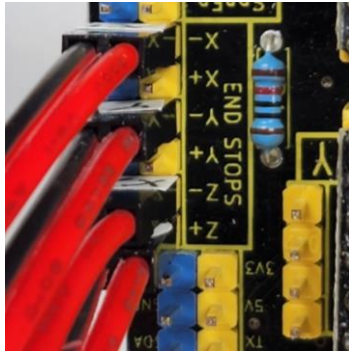

Side View of Home Switch Connections

Step 11 Connecting the Stepper Motors to the Controller.

Step 11a Connect the X1 Stepper Motor to the pins of the "X" driver on the Controller. Make sure the blue-wire is at the top.

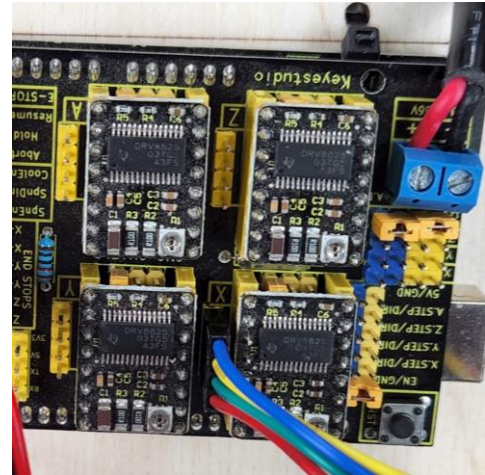

Step 11b Connect the X2 Stepper Motor to the pins of the "A" driver on the Controller. Make sure the red-wire is at the top.

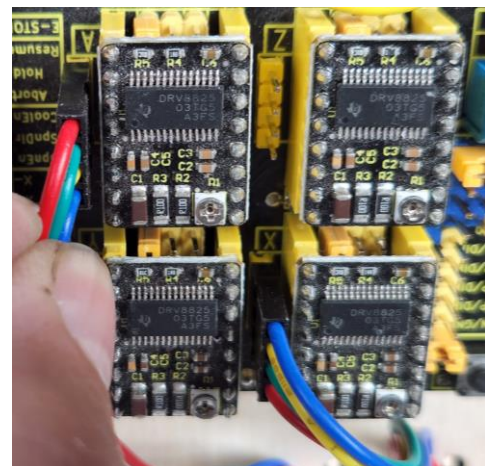

Step 11c Connect the Z Stepper Motor to the pins of the "Z" driver on the Controller. Make sure the blue-wire is at the top.

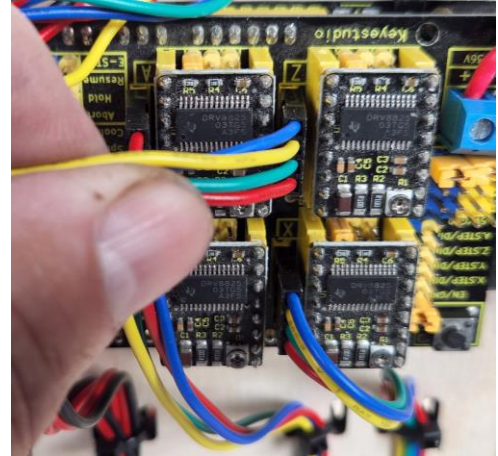

Step 11d Connect the Y Stepper Motor to the pins of the "Y" driver on the Controller. Make sure the blue-wire is at the top.

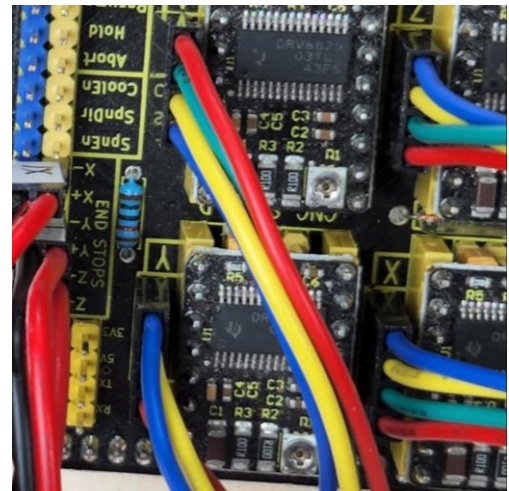





Wire Harness

Wood Components

Part #	Description	Qty	Photo
EQX7	Extension Wire Harness	2	

Required Hardware

Part #	Description	Qty	Photo
H14	M4 X 16 Machine Screws	8	
H15	M4 Nut	8	
PS4	Extension Cord	1	
CB8	60" USB Cable	1	

Illustrated Step by Step Instructions



Step 1 Secure each of the Extension Wire Harness (EQX7) using four of the M4 X 16 Machine Screws and Nuts

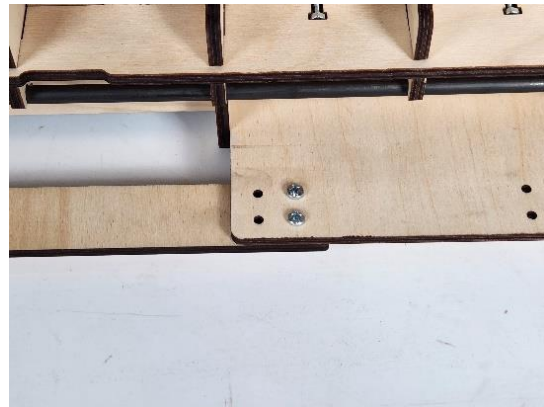

Step 2 Place the large female end of the Extension Cord and Zip tie it to the side of the Gantry Frame Assembly. Plug in the Makita and Power Supply to the Extension Cord



Step 3 Attach the Extension Cord to the Extension Wire Harness with four Zip Ties so that the Extension Cord has plenty of slack when the Gantry is at each end of its travel range.

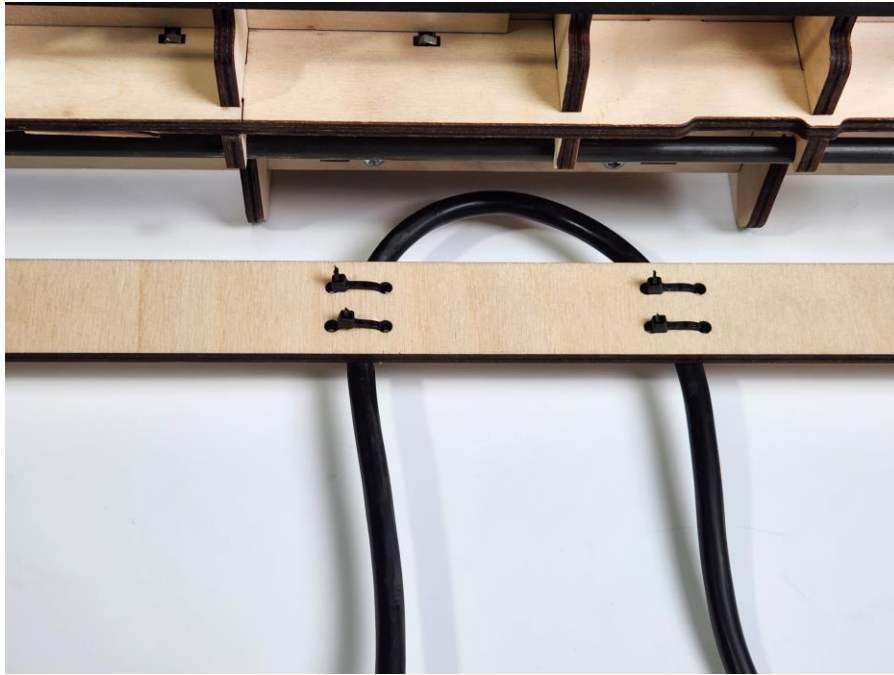

Step 4 Attach the USB Cable to the Controller and route it, as shown.

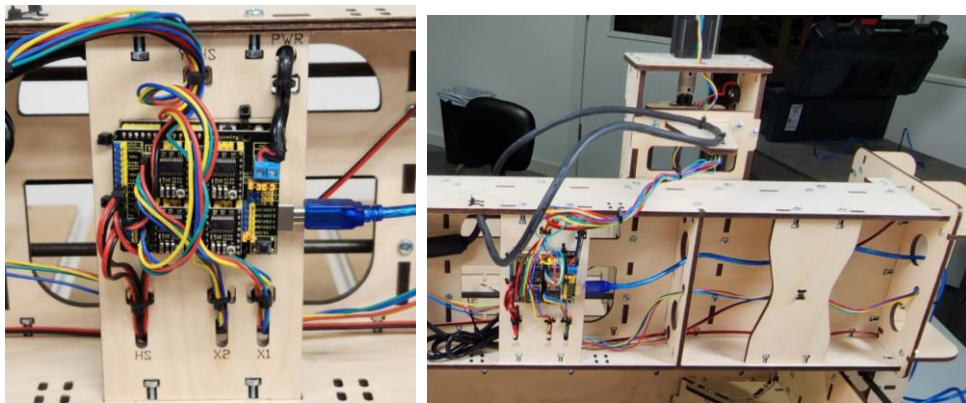

Step 5 Zip Tie the USB Cable to the Side Gantry as shown.

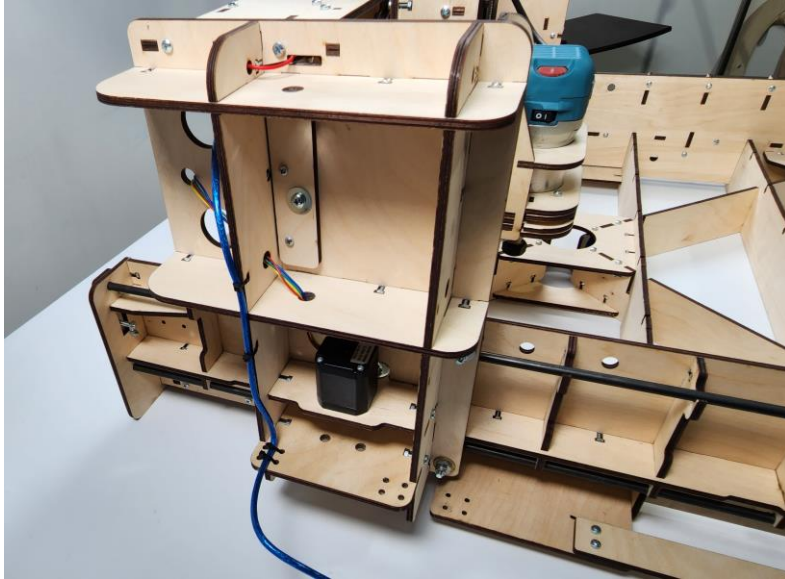

Step 6 Attach the USB Cable to the Extension Wire Harness so that the USB Cable has plenty of slack when the Gantry is at each end of its travel range.

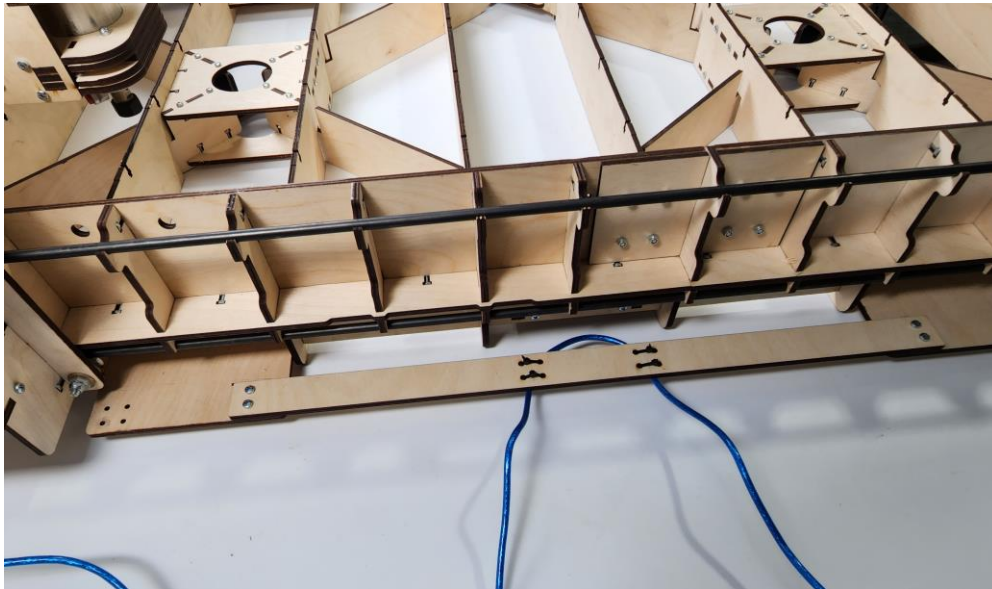



T-Slot Spoilboard

Wood Components

Part #	Description	Qty	Photo
QSB59	MDF Section	6	

Required Hardware

Part #	Description	Qty	Photo
H14	M4 X 16 Machine Screws	60	
H15	M4 Nut	60	
SBT58	Aluminum T-slot	5	

Illustrated Step by Step Instructions

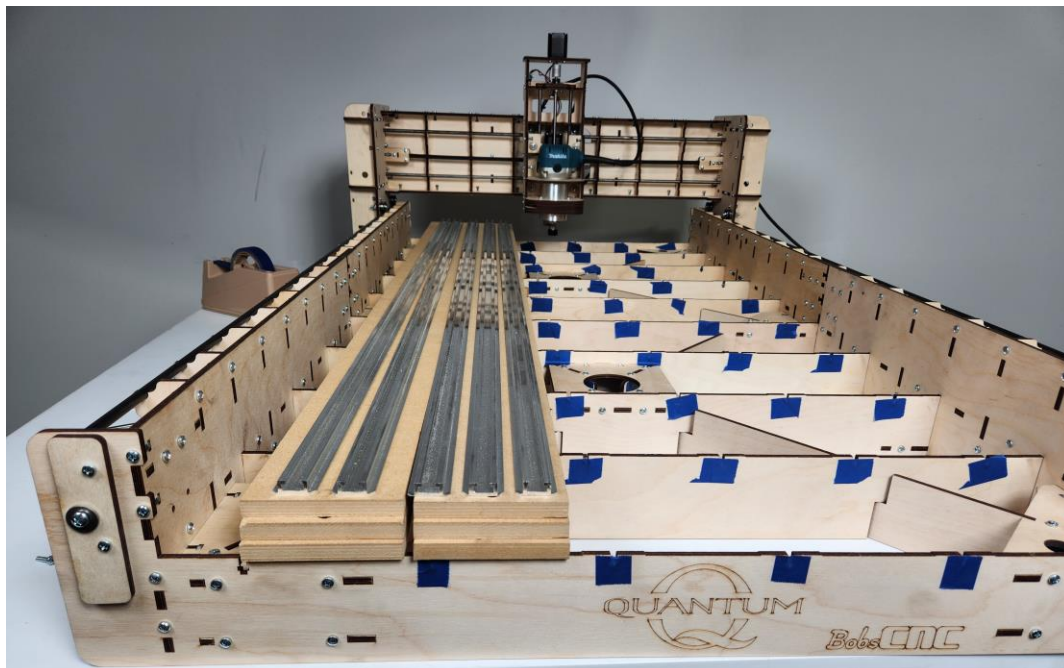

Step 1 Attaching the Spoilboard to the Torsion Box Assembly. The MDF Sections will overhang the front and back end supports $\frac{1}{8}$ inch. The Aluminum T-Slots will fit flush to the front and back of the end supports.

Step 1a Fill the T-slots with sixty M4 Nuts. Cover the T-slots with blue painter's tape to hold the M4 Nuts in place during the installation process.

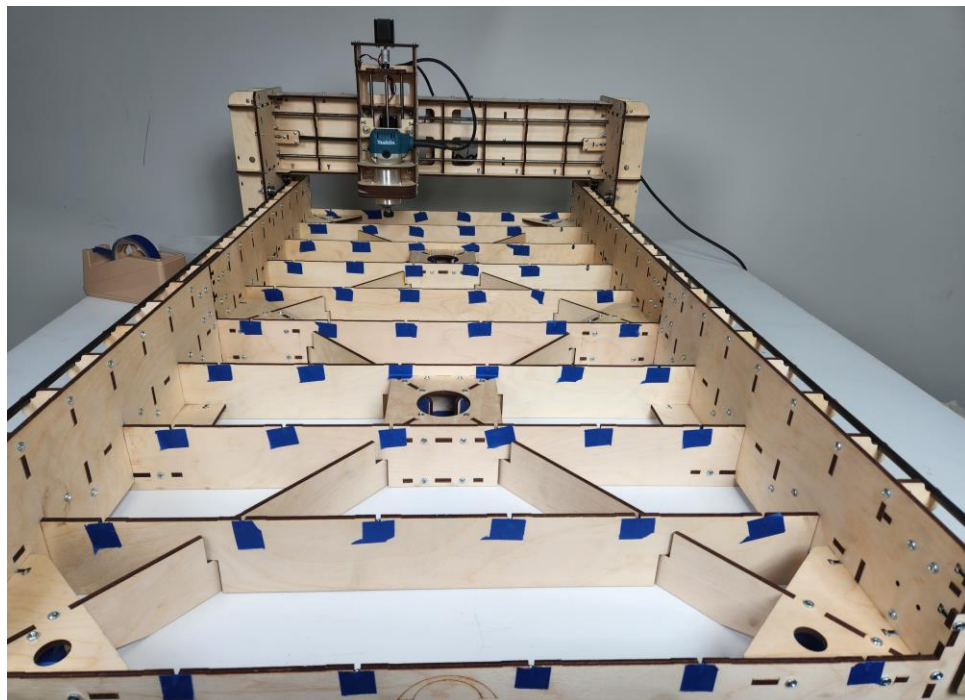

Step 2

Lay the first MDF Section against the left side of the X Frame Assembly as shown. Make sure the countersunk openings are facing up. Align the holes with the installed M4 nuts beneath. Install the Machine Screws to hold each Section in place but do not tighten them at this time.



Step 3

Lift the MDF Section and set the flange of the Aluminum T-Slot so that the MDF covers it completely. Align the front and back end of the Aluminum T-Slot flush with the front and back end panels as shown.



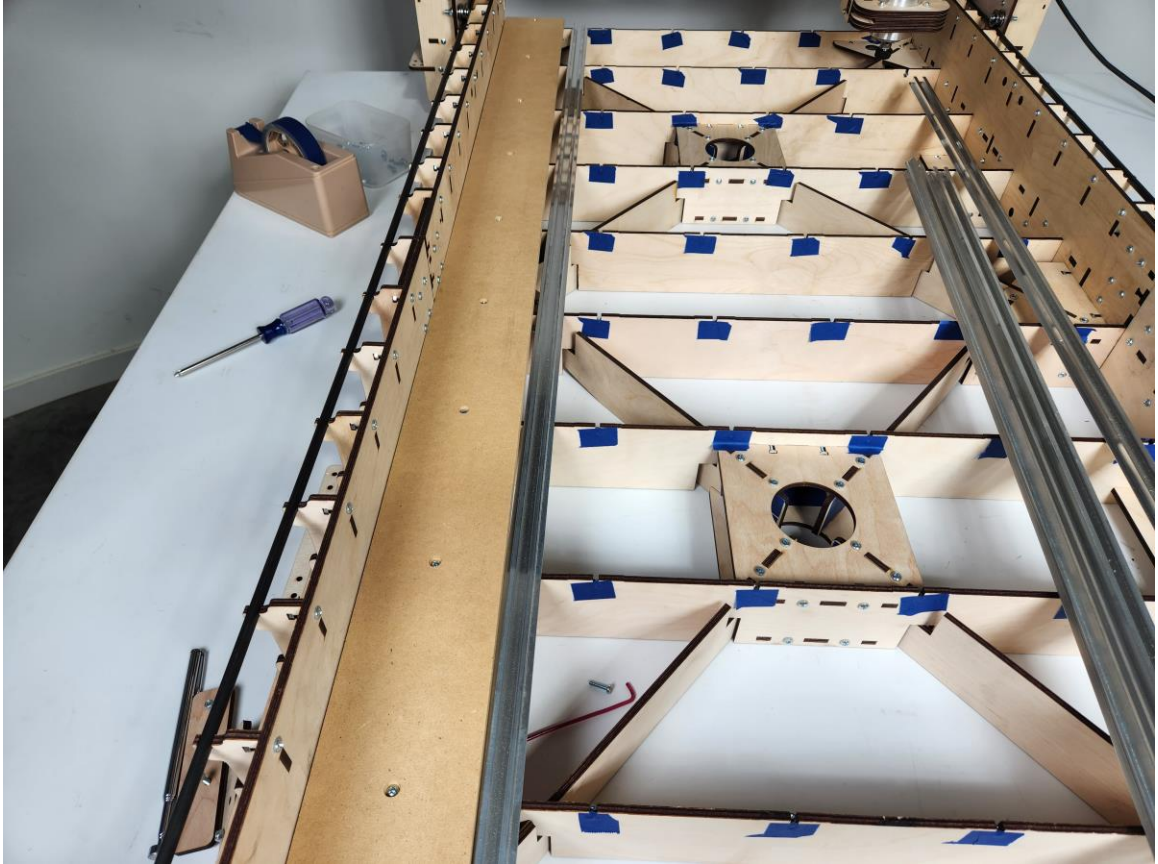

Step 4 Repeat to install the remaining Sections and Aluminum T-slot extrusions.



Step 5

Snug the sixty M4 x 16 Machine Screws into the M4 Nuts but do not fully tighten them. Measure the Spoilboard diagonally from corner.

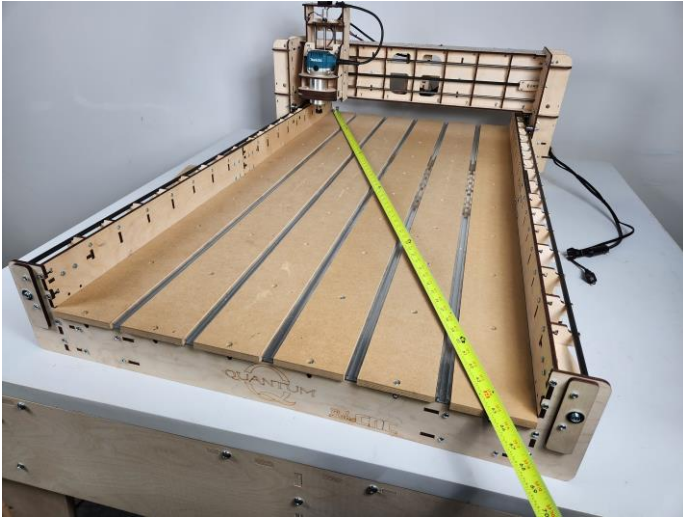

When both measurements match, the spoilboard is square and the Machine Screws can be securely tightened.

Completed Views

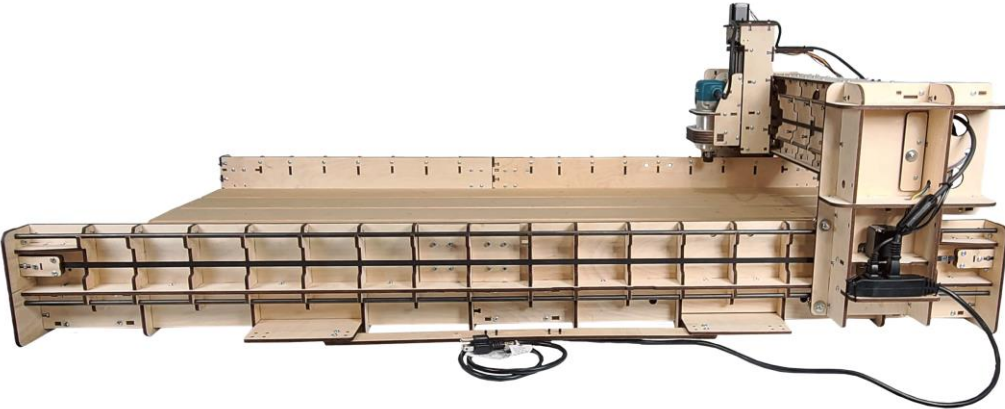

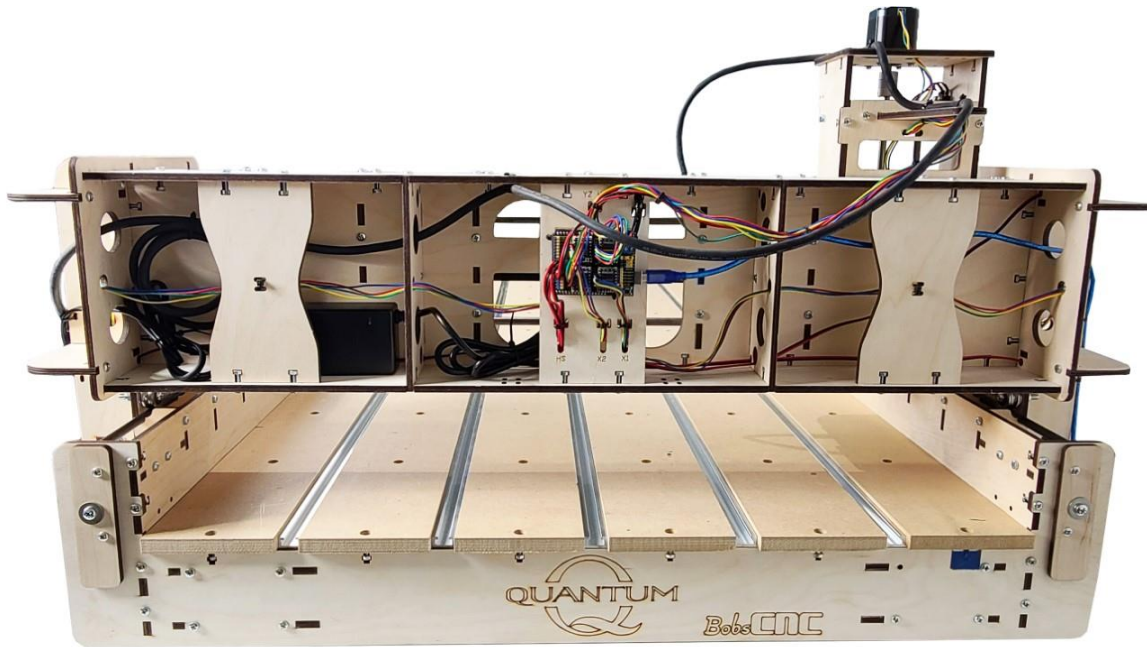
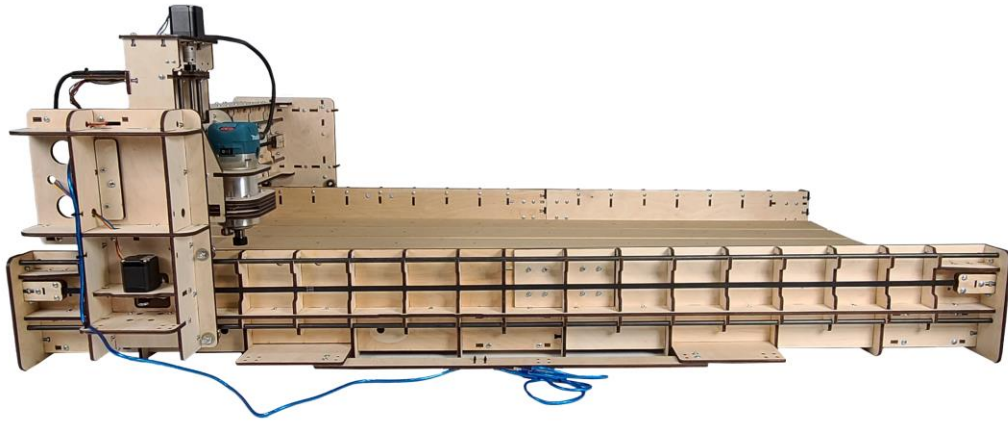

Tramming

Tramming is the process of adjusting a CNC Spindle (Router) so it is perpendicular to the spoilboard. The simplest method to do this is to use a square as shown. If the Spindle is not perpendicular, the Evolution Series CNC Routers can be trammed on the X axis by adjusting the four Eccentric Spacers on the Z Carriage.

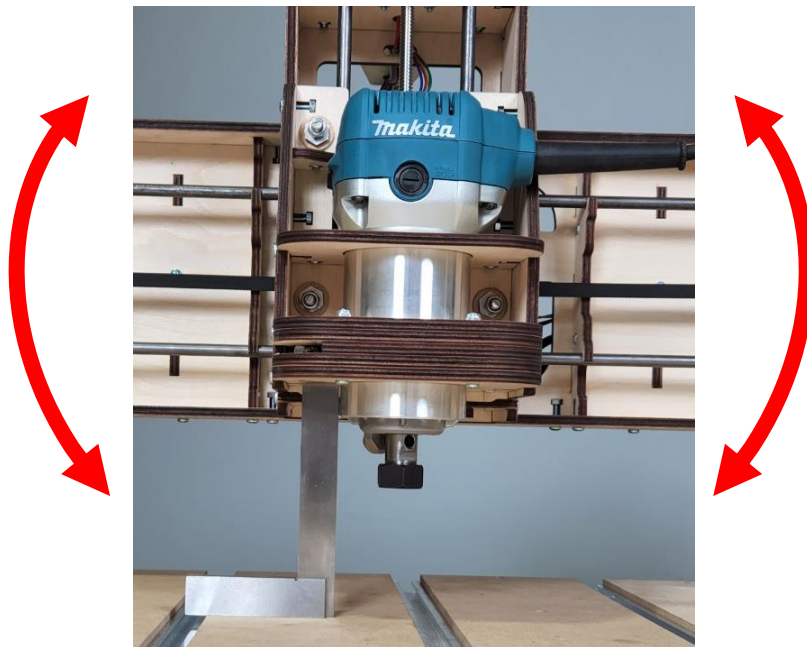

The Spindle (Router) can be trammed on the Y axis by placing shims behind the SG20U Bearing Fender Washer on the upper or lower Y Assembly. Placing the shim on the top will tilt the axis clockwise. Placing the shim on the bottom will tilt the axis counterclockwise.



Clamping System

Wood Components (Included with Kit)

Part #	Description	Qty	Photo
A1	Clamp (long)	4	
A2	Clamp (short)	4	

Required Hardware

Part #	Description	Qty	Photo
H9 H45 H62	1/4- 20, 2" Screws, Wingnuts, T-Nuts	8 ea.	

The BobsCNC supplies wooden clamps that are secured to the aluminum T-Slots using 1/4 X 20 Machine Screws in conjunction with T-Nuts and Wingnuts. The T-Nuts slide into the aluminum T-Slots and can be tightened within the slot. The Wingnuts tighten the wooden clamps against the workpiece to hold it in position during the cutting process.



Congratulations! You Just Completed
the Assembly of Your BobsCNC
Quantum CNC Router.

Please use the link where to download our Basic CAM
and Basic SENDER

Basic Software Suite

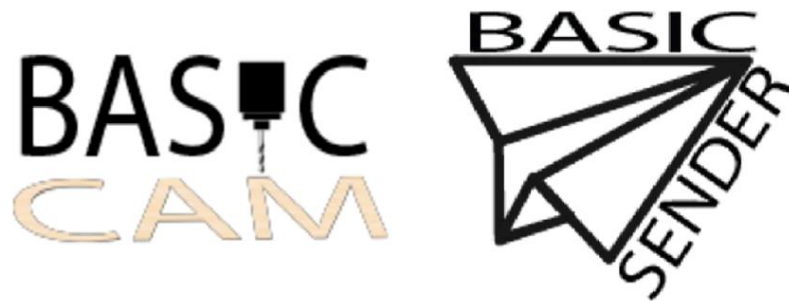

Note: Once connected to Basic SENDER you will need to go to the **Firmware Flashing Tool** in the **Tools and Wizards** menu, select the Quantum Max, and the correct com port, then flash the controller.

Appendix

Firmware Values

Key	Value	Description
\$0	10	(step pulse, usec)
\$1	25	(step idle delay, msec)
\$2	0	(step port invert mask:00000000)
\$3	0	(dir port invert mask:00000000)
\$4	0	(step enable invert, bool)
\$5	0	(limit pins invert, bool)
\$6	0	(probe pin invert, bool)
\$10	1	(status report mask:00000011)
\$11	0.01	(junction deviation, mm)
\$12	0.002	(arc tolerance, mm)
\$13	0	(report inches, bool)
\$20	1	(soft limits, bool)
\$21	0	(hard limits, bool)
\$22	1	(homing cycle, bool)
\$23	3	(homing dir invert mask:00000011)
\$24	250	(homing feed, mm/min)
\$25	2000	(homing seek, mm/min)
\$26	250	(homing debounce, msec)
\$27	5	(homing pull-off, mm)
\$30	1000	Maximum spindle speed, RPM
\$31	0	Minimum spindle speed, RPM
\$32	0	Laser-mode enable, boolean
\$100	80	(x, step/mm)
\$101	80	(y, step/mm)
\$102	400	(z, step/mm)

\$110	10000	(x max rate, mm/min)
\$111	10000	(y max rate, mm/min)
\$112	2000	(z max rate, mm/min)
\$120	500	(X-axis acceleration, mm/sec ²)
\$121	500	(Y-axis acceleration, mm/sec ²)
\$122	500	(Z-axis acceleration, mm/sec ²)
\$130	1283	(X-axis maximum travel, millimeters)
\$131	610	(Y-axis maximum travel, millimeters)
\$132	98	(Z-axis maximum travel, millimeters)

Quantum Washer Size Table

Part number	Description	ID	OD	Thickness (min)	Thickness (max)
H41	Eccentric Washer	0.453	0.750	0.059	0.063
H42	Bearing Fender Washer	0.250	0.750	0.060	0.090
H50	Idler Fender Washer	0.203	0.750	0.043	0.051
H57	Bearing Retainer Washer	0.172	0.050	0.050	0.080
H66	¼ inch Shim Washer	0.256	0.500	0.028	0.035
H88	M3 Washer	0.125	0.312	0.025	0.040
H89	Small Black Washer	0.078	0.188	0.016	0.025