

BobsCNC
Unleash Your Creativity

KL7 SERIES

Controller Assembly Manual

MANUAL 6 of 8



Version 2.3

Table of Contents

Controller Assembly

Safety Information.....	3
Parts List.....	4-9

Assembly Instructions:

Attaching Power Supply to Bottom Plate.....	10-13
Attaching Drivers/UNO Board to Shelf.....	14-18
Connecting Power Supply Wires.....	19-24
Front Panel Assembly with Emergency, Hold & Resume Switches.....	25-26
Attaching Power Switch to Left Side Panel.....	27
Controller Encloser Assembly.....	28-30
Connecting Power and Emergency Stop Switches.....	31-33
Installing Shield and Connecting Control Wires.....	34-49
Connecting the Home Switches.....	50-56
Connecting the Servo Motors.....	57-61
Final Controller Assembly.....	62-63
Attaching the Home Switch Magnets.....	64-66

Look Safety Information and Hints.

	<p>DANGER Indicates a serious risk of bodily harm, possible injury and death. This warning box is to be taken seriously. Any work must be carried out with extreme caution.</p>
---	--

	<p>CAUTION Indicates a possible risk of injury that can result from failure to follow this warning.</p>
---	--

	<p>WARNING Indicates the possible damage to the machine, it's components, or the work piece that can result from the failure to follow this warning.</p>
---	---

 <p>HINT</p>	<p>Hints will provide needed information, shortcuts, and insights that will make assembly and machine operation easier and safer.</p>
--	---



Please review each assembly manual before beginning to assemble the KL7 SERIES CNC Router.

**Please refer to the 24" x 18" Controller Wiring Diagram enclosed with your
KL7 SERIES CNC Router Kit.**

Parts List

Parts for assembly include:

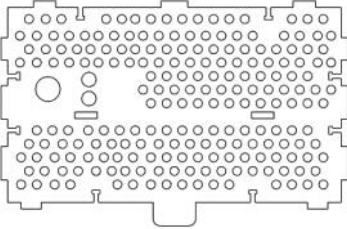
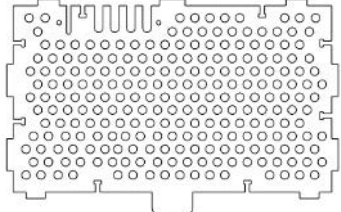

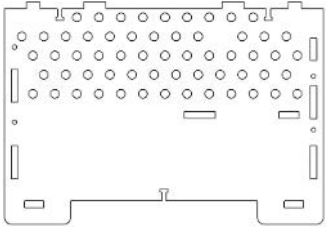
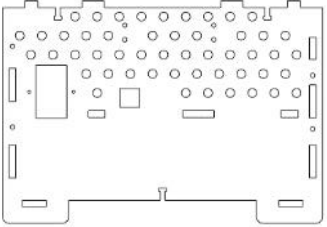
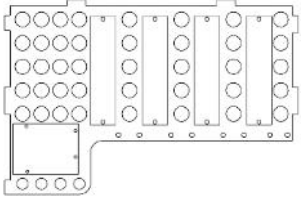

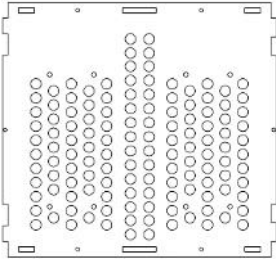
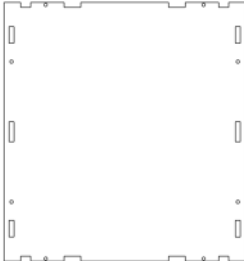









Wood Components

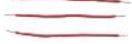

Part #	Description	Qty	Photo
C1	Front Panel	1	
C2	Back Panel	1	
C3	Wire Clamp	1	
C4	Right Side Panel	1	
C5	Left Side Panel	1	
C6	Driver/Uno Shelf	1	

Part #	Description	Qty	Photo
C7	Bottom Plate	1	
C8	Top Plate	1	

Hardware and Electrical Components

Part #	Description	Qty	Photo
H26	Small Zip Ties	10	
H14	M4 x 16 Machine Screws	40	
H15	M4 Nuts	40	
H27	M2.5 x 16 Machine Screws	6	
H28	M2.5 x 16 Nuts	6	
H29	3mm Spacer	4	
H30	8mm Spacer	8	
E1	KL-350-148 110V AC 48V DC Power Supply	2	
E2	24 V Servo Driver	4	
E3	Uno	1	
E4	Uno Screw-Shield	1	
E5	Power Supply Switch	1	
E6	Emergency Off Switch	1	
E7	Hold Switch	1	
E7	Resume Switch	1	

Part #	Description	Qty	Photo
E9	#14 Black 440mm AC Power Wire (fork/fork) (fork/female)	2	
E10	#14 White 210mm AC Neutral Wire (fork/fork)	1	
E11	#14 White 140mm AC Neutral Wire (fork/female)	1	
E12	#14 Green 210mm AC Ground Wire (fork/fork)	1	
]E13	#14 Green 140mm AC Ground Wire (fork/female)	1	
E14	#14 Black 210mm (fork/fork)	1	
E15	#22 White 320mm #22 Purple 320mm	1 ea.	
E16	#18 Black/Red 350mm DC Power Wires	4	
E17	#22 Orange 250mm #22 Blue 250mm	1 ea.	
E18	#22 Red 180mm with ferrite	1	
E19	#22 Red 80mm wires	3	
E20	#22 White 320mm	1	
E21	#22 Brown 160mm #22 Gray 160mm #22 Yellow 160mm #22 Green 160mm	1 ea.	
E22	#22 Black 200mm	1	
E23	#22 Black 130mm	1	
E24	#22 Black 80mm Jumper	4	

Part #	Description	Qty	Photo
E25	#22 Black 40mm Jumpers	8	
E26	#22 Brown, Blue 80 mm	1 ea.	
E27	Power Cord	1	

Attaching Power Supply to Bottom Plate

	<p>CAUTION</p> <p>Make certain the Power Supply Selector Switch is set to 110V as seen below. Failure to do so will negatively affect machine performance.</p>
---	---

Step 1.0 Switch power selector to the 110VAC as shown.

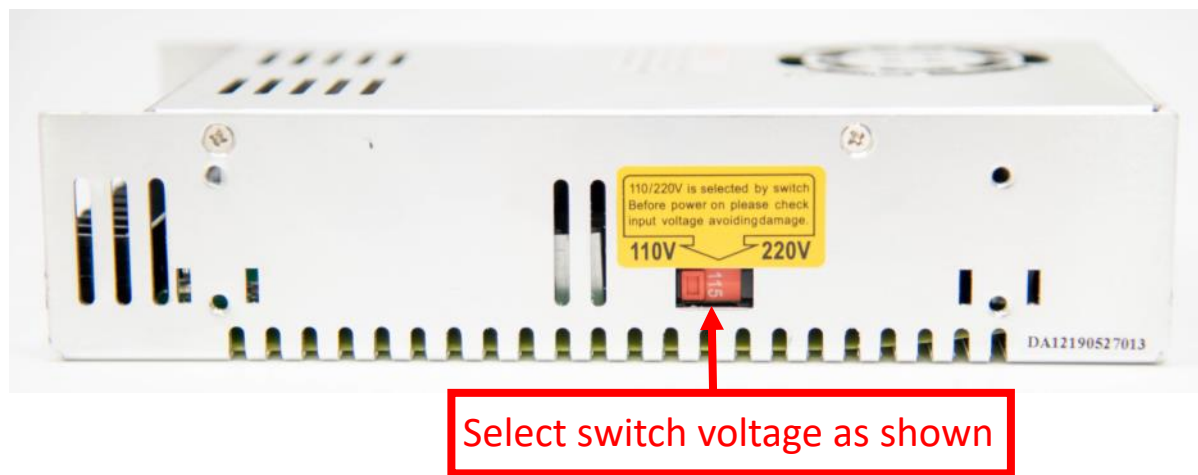

Step 1.1 Turn the C7 Bottom Plate over so that the lasered letter are face down. Insert four M4 x 16 Machine Screws through the Bottom Plate for each Power Supply as shown.

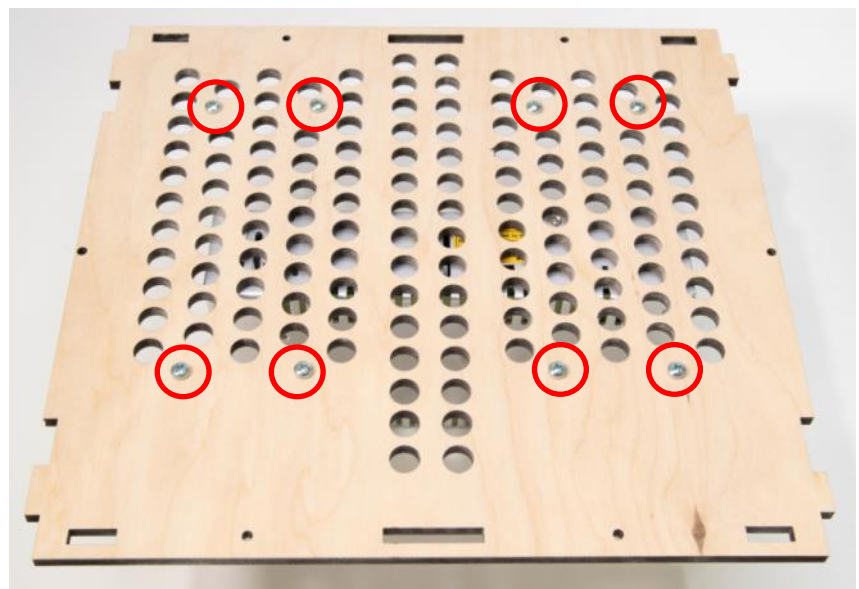

Step 1.2

Use blue painter's tape to hold the Machine Screws temporarily in place as shown below.

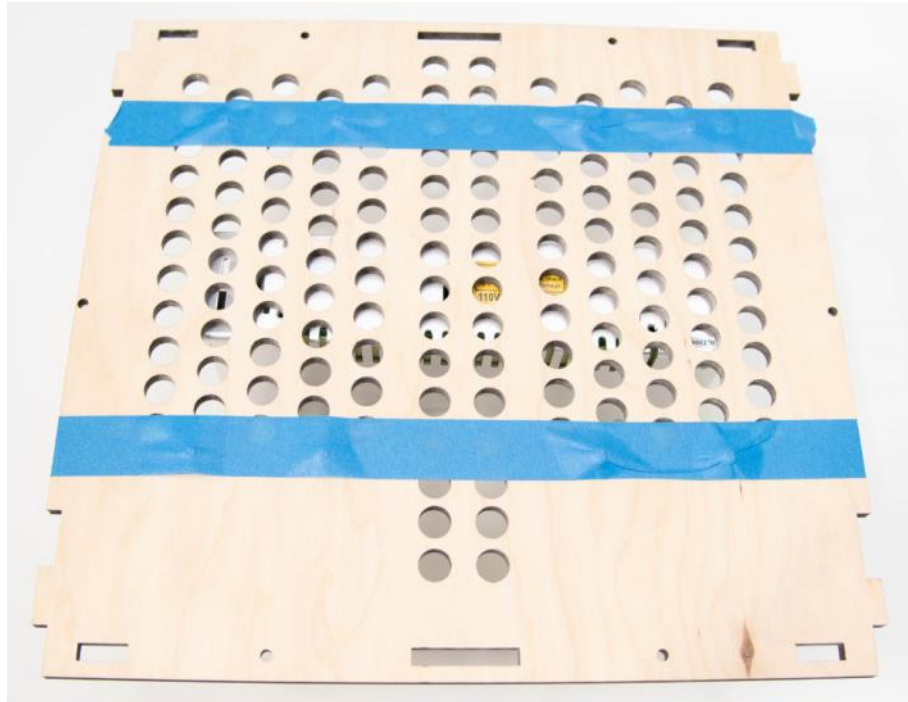

Step 1.3

Gently rotate the Back Plate so the Machine Screw threads are visible. Slip a 8mm Spacer over each of the four of the Screws as shown.

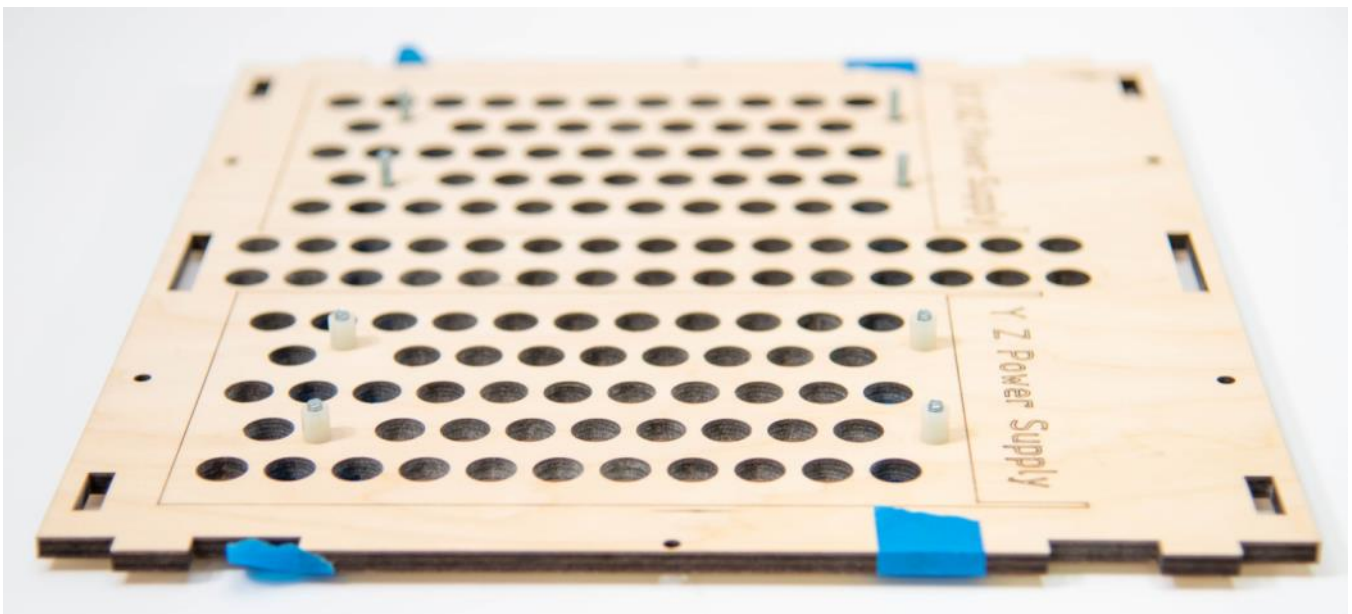



CAUTION

Spacers are used to create an air space to facilitates air flow around each Power Supply and the Uno Controller. Failure to use the spacers may cause the Power Supply to overheat and/or fail.

Step 1.4 Carefully orient the receiver holes on the bottom of the Power Supply over the Screws and Spacers.

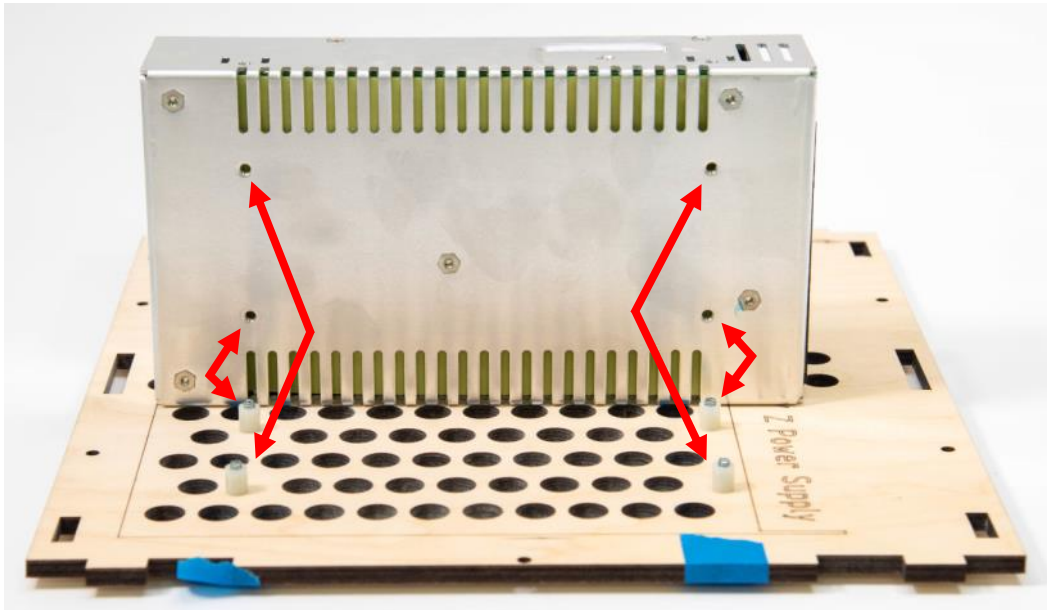

Step 1.5 Apply light pressure to hold the Power Supply and Screws together and gently turn the Bottom Plate and Power Supply over.



Step 1.6

With the Power Supply beneath the Bottom Plate, carefully remove the painter's tape to expose one M4 X 16 Machine Screw and tighten securely with a Phillips head screwdriver. (repeat for until all four M4 X 16 Machine Screws are secure. Be sure the spacers remain in place.)

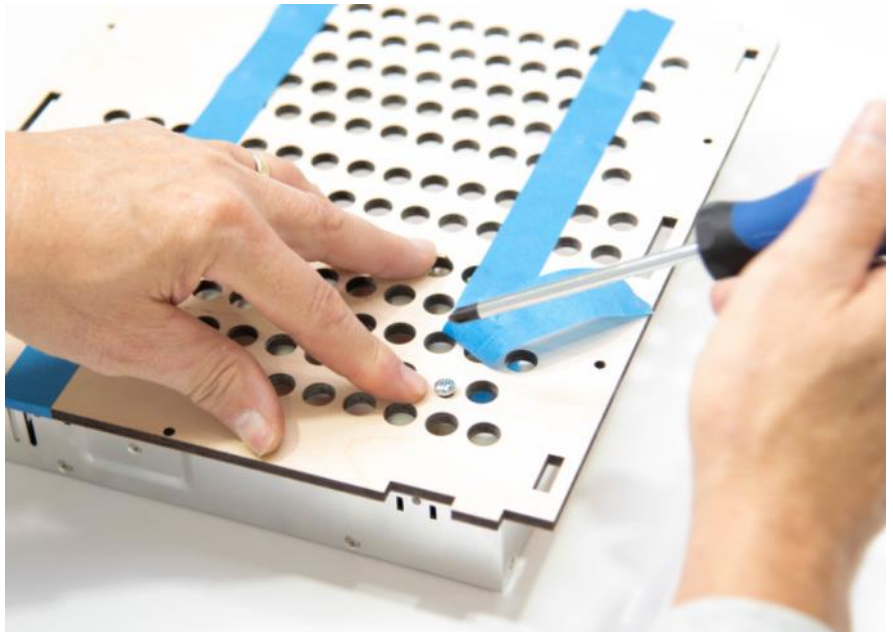

NOTE: Do not over tighten the Machine Screws.

Step 1.7 Repeat the process to secure the second Power Supply to the Bottom Plate. The Power Supplies should stand off the Bottom Plate as shown.



Attaching Drivers/UNO board to Shelf

Step 2.0 Place DIP switch to the correct position as shown.



	<p>CAUTION</p> <p>Make certain the “1” and “4” DIP (Dual In-Line Package) Switches are set as shown. If the switches are not set correctly the Servo Motors will not operate properly.</p>
--	---

Step 2.1 Insert four M4 x 16 Screws through the mounting holes on one side of the C6 Driver Shelf as shown. Partially thread an M4 nut on each Screw as shown below.



Step 2.2

Align DIP Switch end of the driver to face the Axis Designation (X1, X2, Y and Z). Elevate the Screw head and slip the Drive base slot around the Screw. Then holding Base snug against the Screw, insert a M4 x 16 Screw through the opposite end and secure with a Nut. Tighten both Nuts firmly.

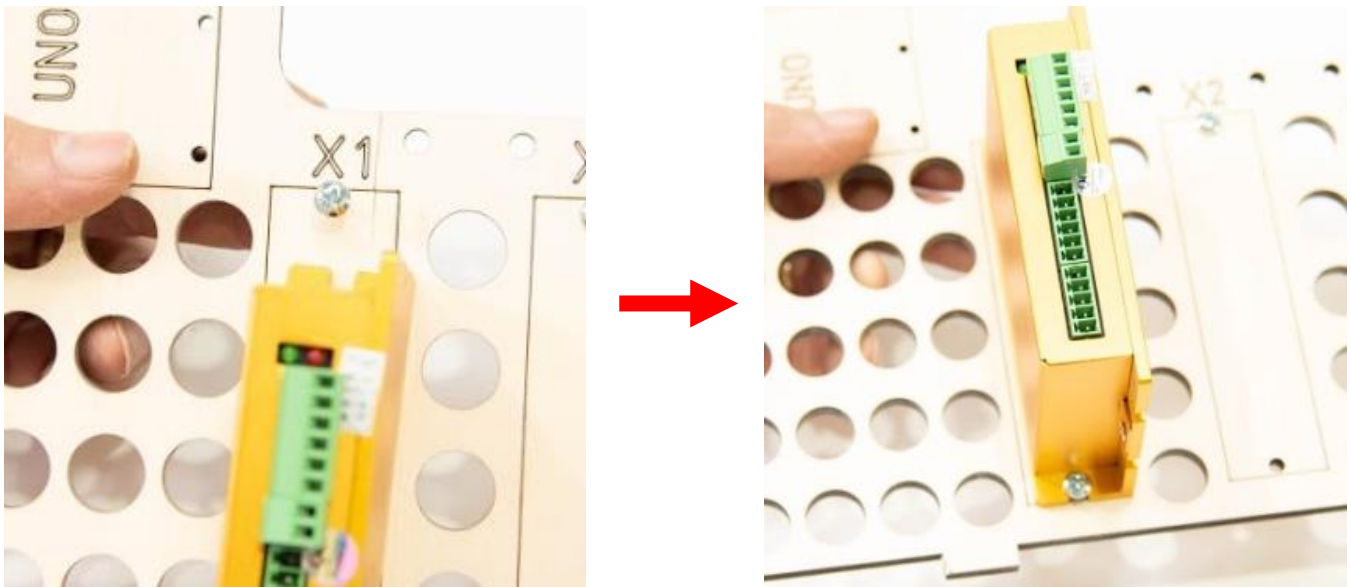

Step 2.3

Repeat until all four drivers are securely mounted as shown.

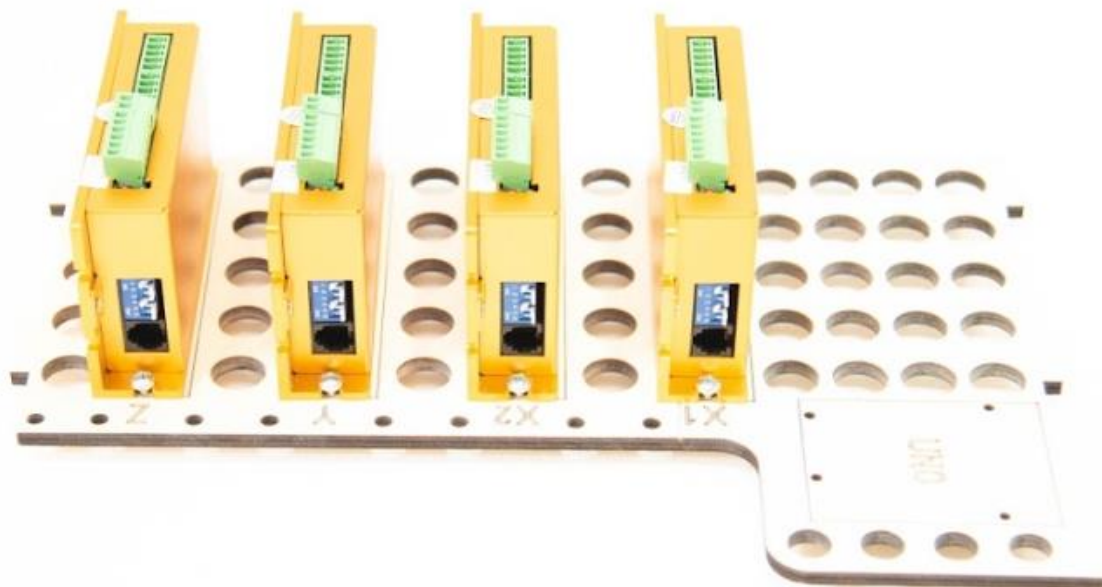

Step 2.4

Carefully center the four 3mm Spacers above each of the mounting holes on the UNO Template as shown.

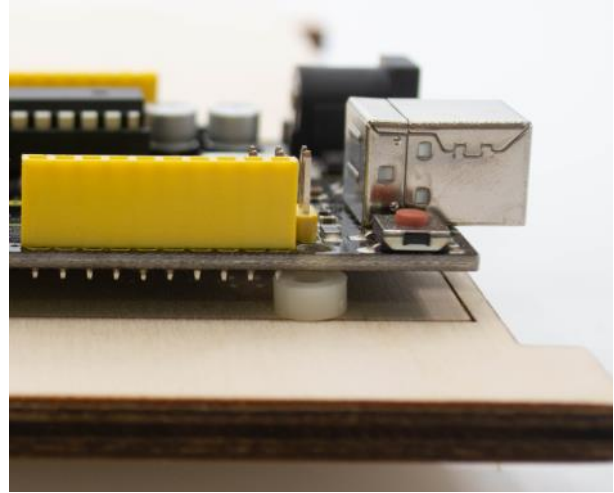
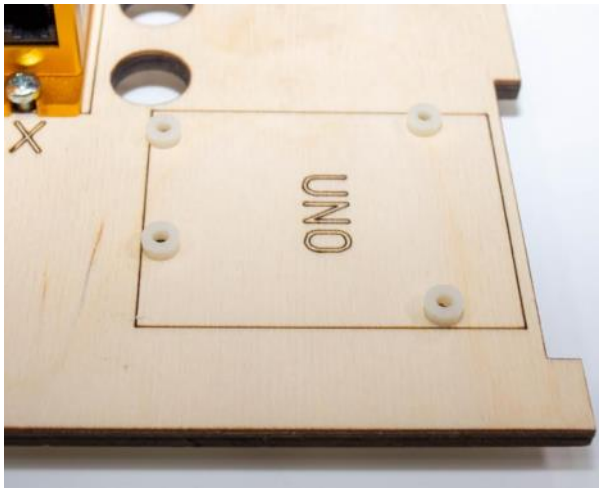

Step 2.5

Gently orient the mounting hole of the UNO Board over the Spacers and place one M2.5 x 16 Machine Screw through each of the four mounting holes as shown.

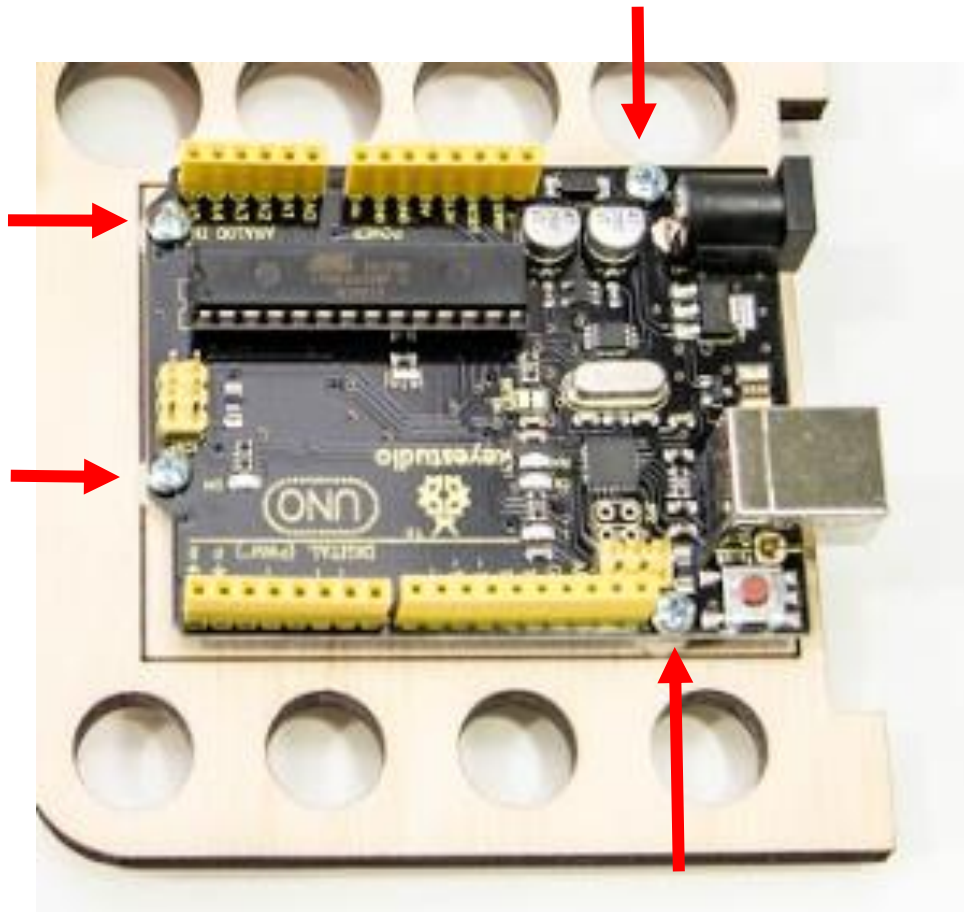

Step 2.6

Hold Screw heads in place with pieces of blue painter's tape.

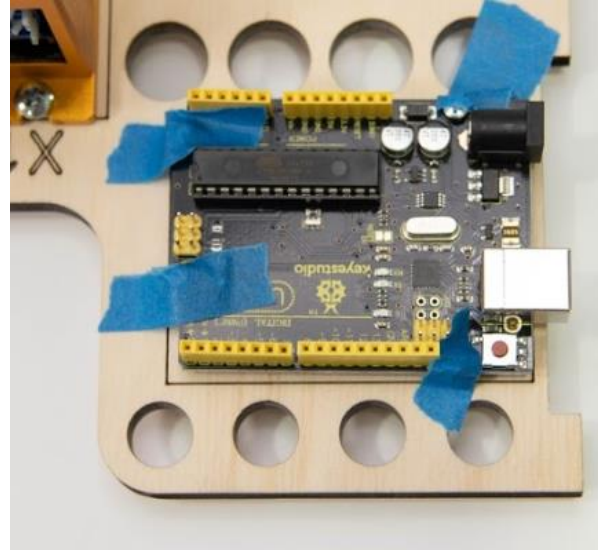

Step 2.7

Thread a M2.5 Nut onto each of the Screws and secure. Do not over-tighten the Screws and Nuts to protect the UNO board.



The completed installation is shown below. The orientation of the Servo Drivers and the Micro Controllers is important.

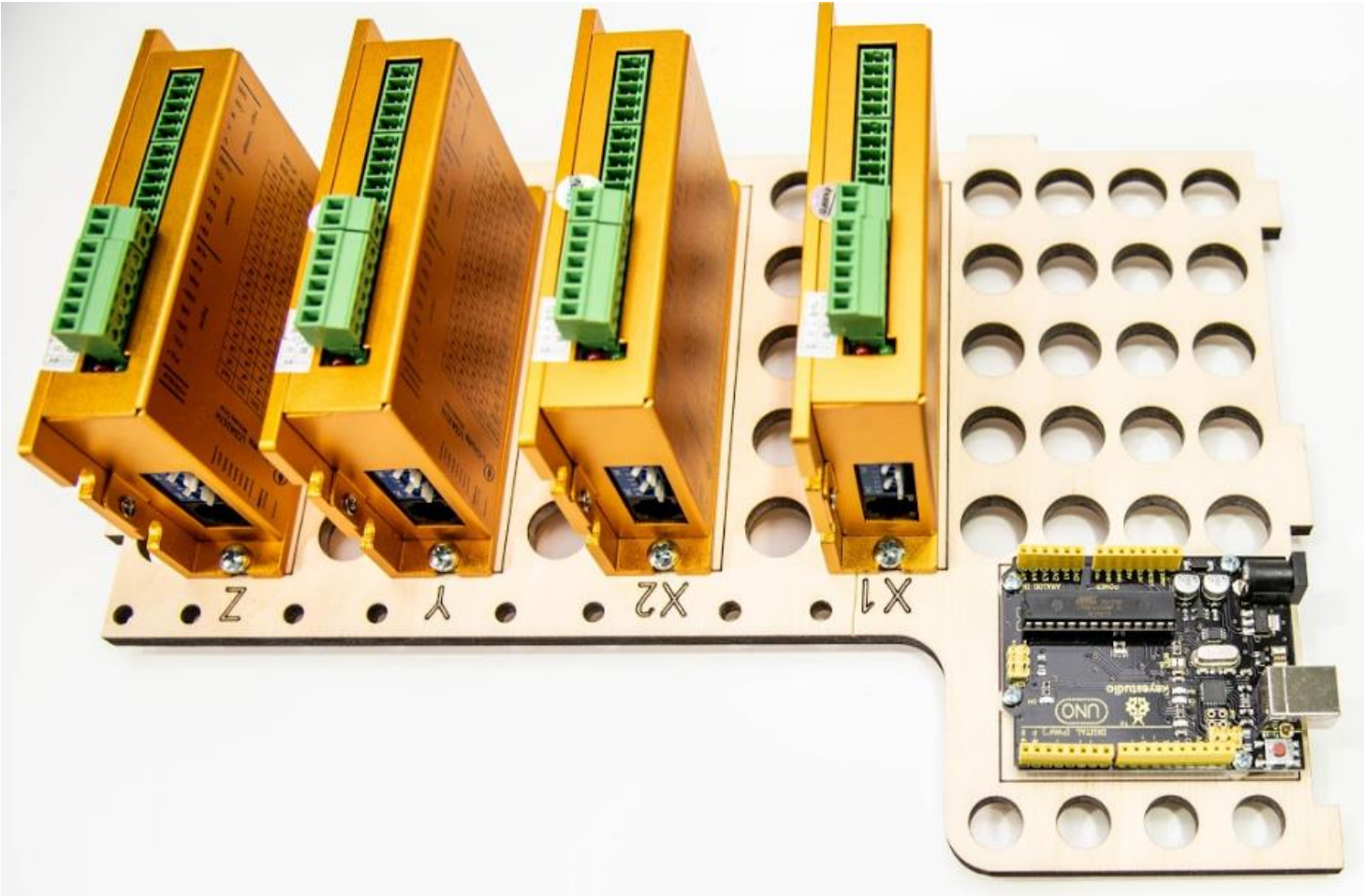

Connecting Power Supply Wires

	<p>DANGER: Possibility of electrical shock, burn(s), and or damage to the electrical components . Wiring connections should be performed by a licensed electrician. Do not remove power supply cover. Turn off and disconnect all electrical power when servicing power supply, controller, or drivers.</p>
---	--

	<p>CAUTION It is essential that every wire connection is made correctly. Incorrect wiring may result in machine and/or component failure, and electrical interference. After every wire connection is made, securely tighten the terminal screw and firmly tug on the attached wire to ensure that it is securely connected. Always refer to the KL7 Series Controller Wiring Diagram when following the instructions in this manual.</p>
--	--

Step 3.0 Connect Power Supply earth ground terminals using the #14 Green 210 mm AC Ground wire (fork/fork) as shown.

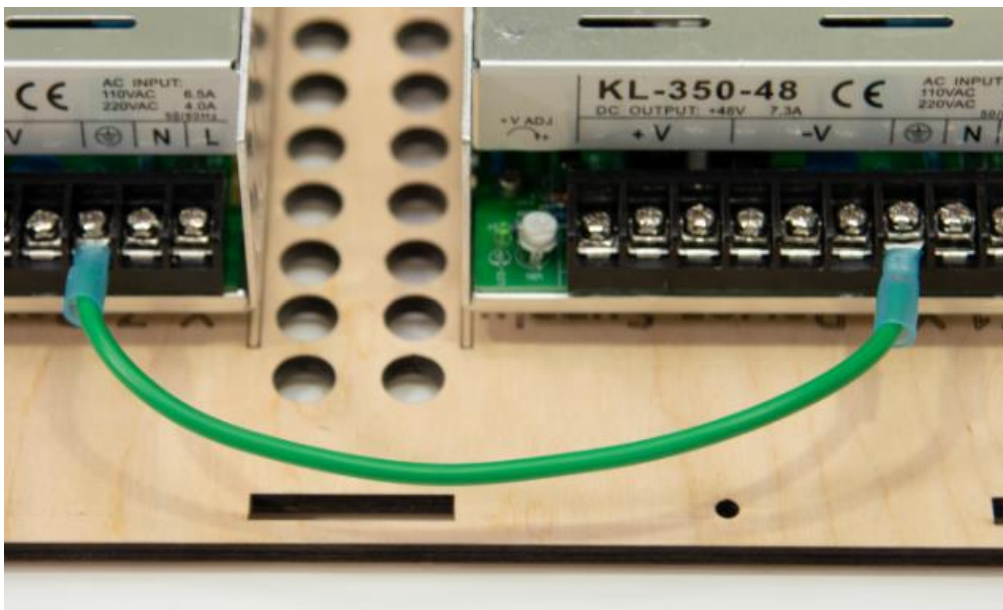

Step 3.1

Connect the #14 Green 140 mm AC Ground Wire (fork/female) to earth ground on Power Supply as shown.

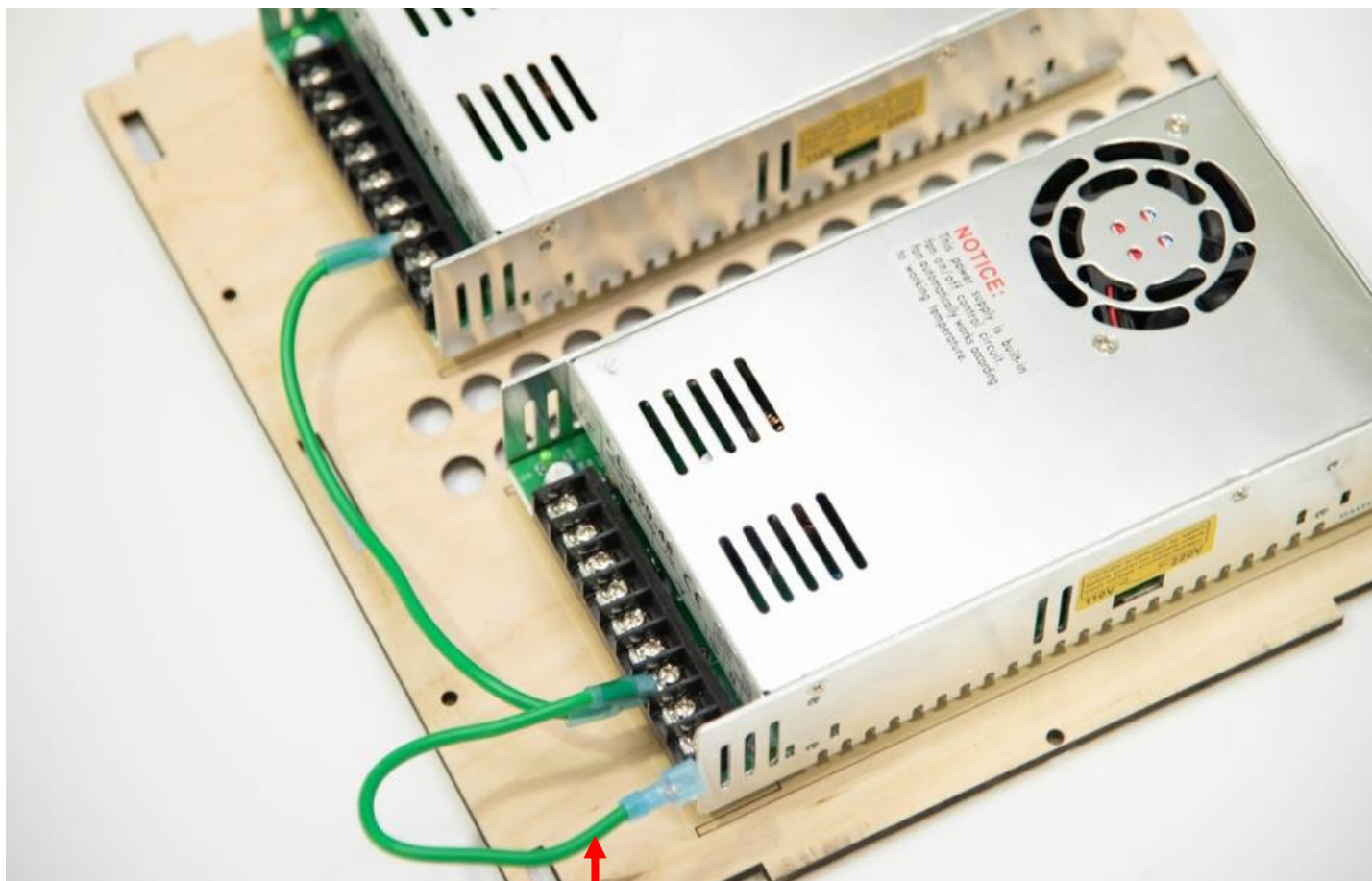

NOTE: The female connector will be connected in a later step.

Step 3.2

Connect Power Supply neutral terminals using the #14 White 210mm AC Neutral Wire (fork/fork) as shown.

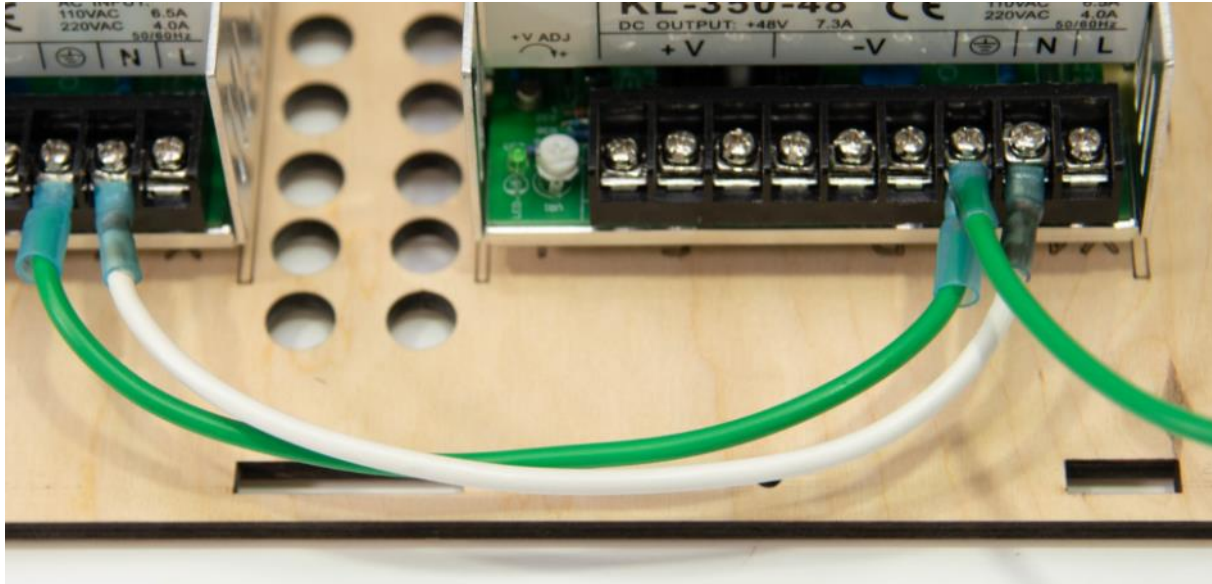

Step 3.3

Add #14 White 140mm AC Neutral Wire (fork/female) to the neutral terminal on Power Supply as shown.

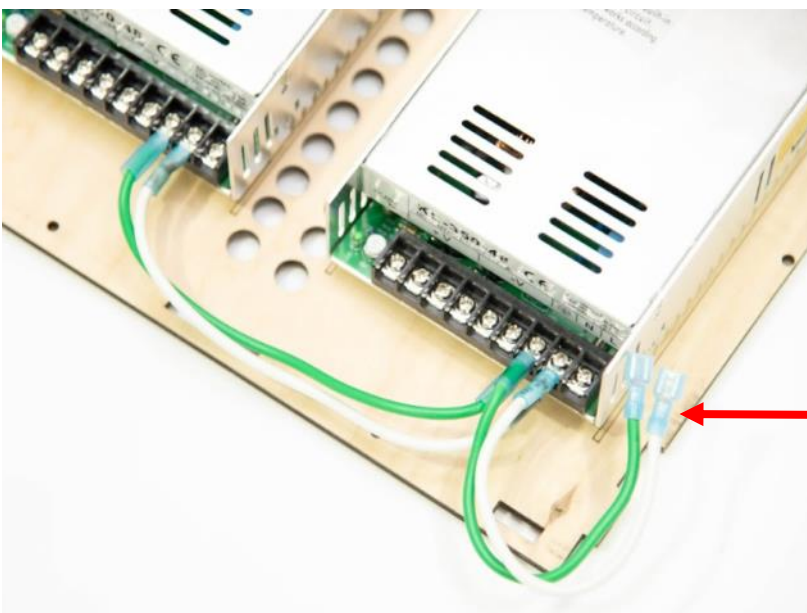

NOTE: The female connector will be connected in a later step.

Step 3.4

Connect Power Supply load terminals using the #14 Black 210mm AC Power Wire (fork/fork) as shown.

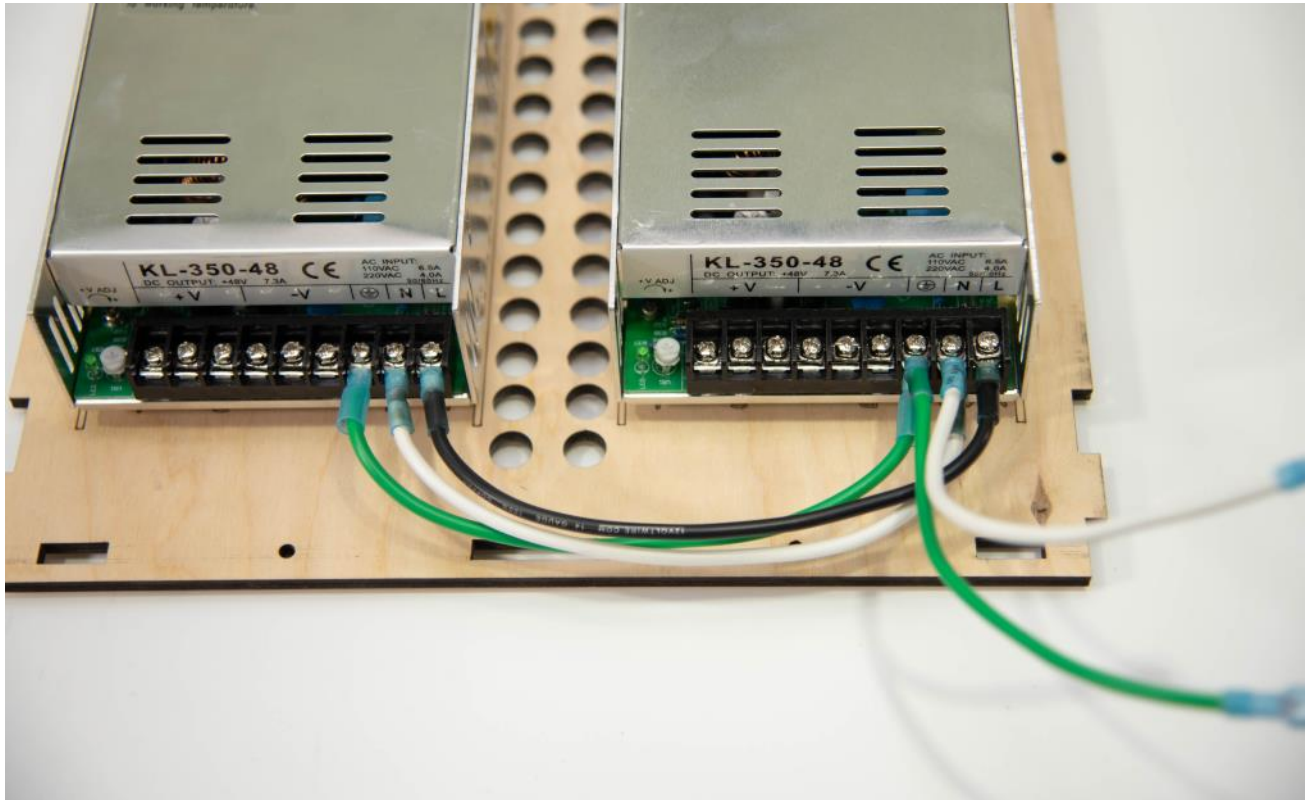

Step 3.5

Connect the #14 Black 440mm AC Power Wire (fork/fork) to load terminal on Power Supply as shown.

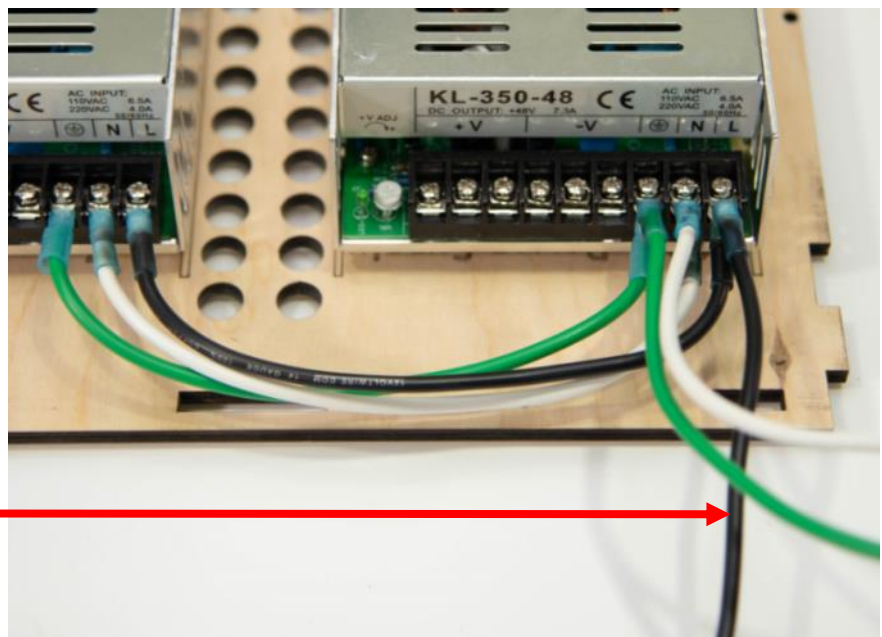

NOTE: The forked terminal will be connected in a later step.

Step 3.6

Connect the Power Supply (-V) DC ground terminals using the #22 Black 210mm wire as shown.

NOTE: The DC ground wire must be routed neatly beneath the AC wires as shown below.

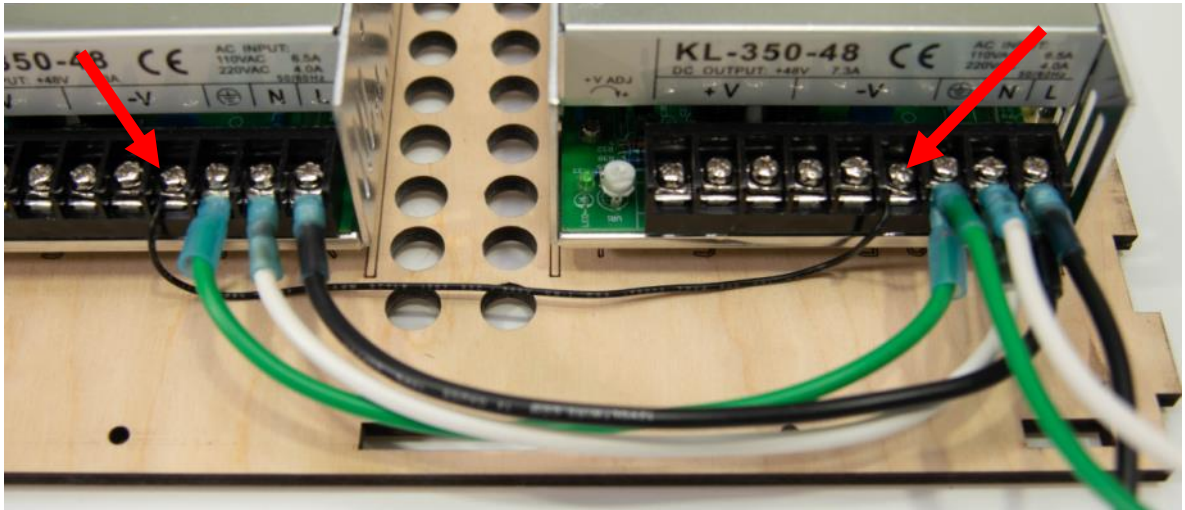

Step 3.7

Connect a #22 Black 130 mm wire to the Power Supply (-V) DC ground terminal as shown below. **NOTE:** The free end of this wire will be connected to the UNO ground in a later step.

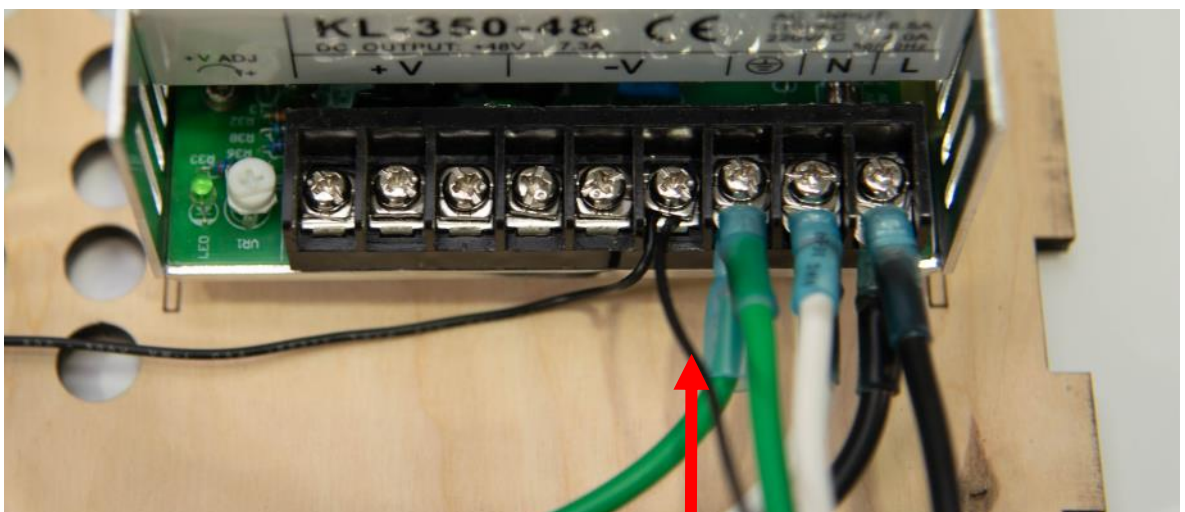

NOTE: This wire will be connected in a later step.

Step 3.8 Attach the Red/Black #18 350 mm wires to the Power Supply as shown. Note the red wires to +V and the black wires to the -V as shown. There are two sets of wires for each Power Supply.

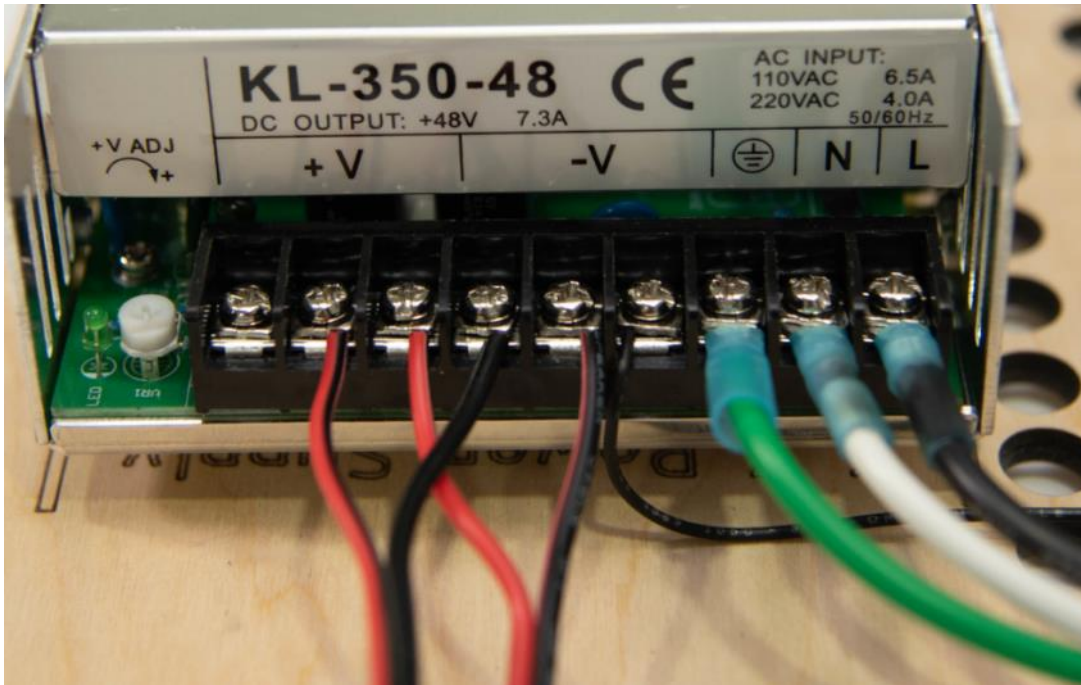

Step 3.9 Attach the #18 Black/Red 350 mm wires to the second Power Supply as shown. Note the red wires to +V and the black wires to the -V as shown. NOTE: These four pair will be connected to the Drivers in a later step.

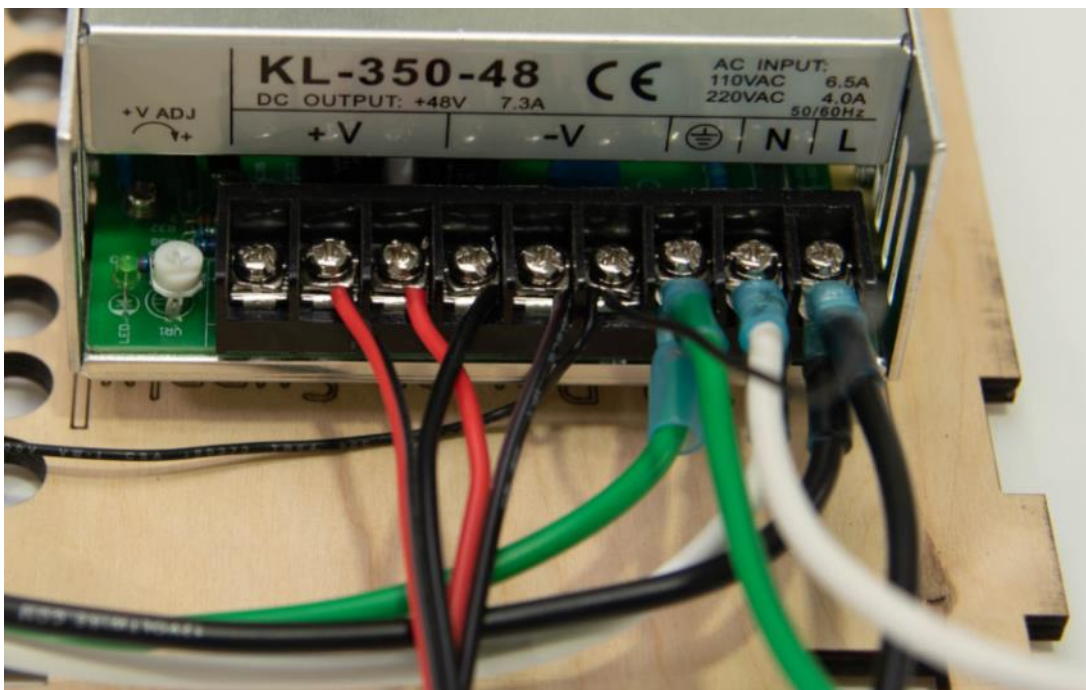

Front Panel Assembly with Emergency Stop, Hold, and Resume Switches

Step 4.0

To attach the Emergency Stop Switch to the Front Panel, first disconnect the red button from the switch base by depressing and turning the twist lock.



Step 4.1

Next, use a small Phillips screwdriver to back out the mounting screws until the end of the screw is flush with the base.



Step 4.2

Place the red button through the large hole in the C1 Front Panel as shown (terminal block on top) and reattach the twist lock base. Turn the mounting screws until they hold the switch firmly in place. **NOTE:** The black plastic terminal block is facing up as shown.

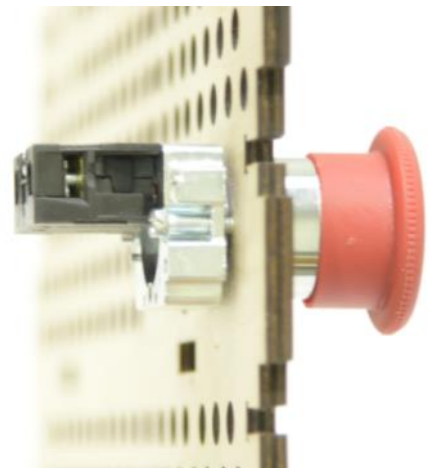

Step 4.3

Attach the Yellow “Hold” button by first removing the plastic nut from the back of the button switch. Insert the switch wires and the threaded base through the hole marked “Hold” on the front panel and secure by firmly reattaching the plastic nut.

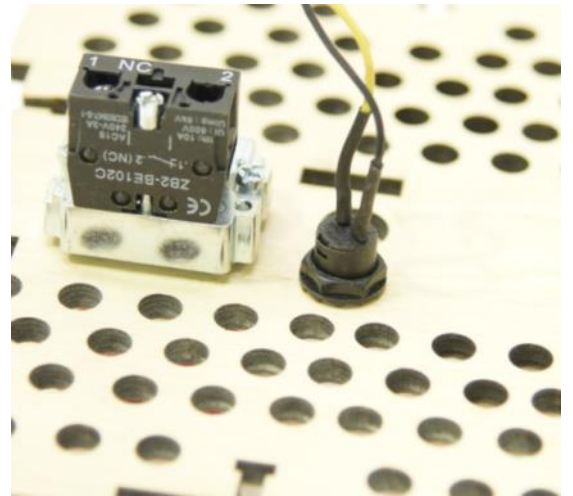

Step 4.4

Repeat steps to attach the Green “Resume” button.

The Front Panel should be assembled as shown.

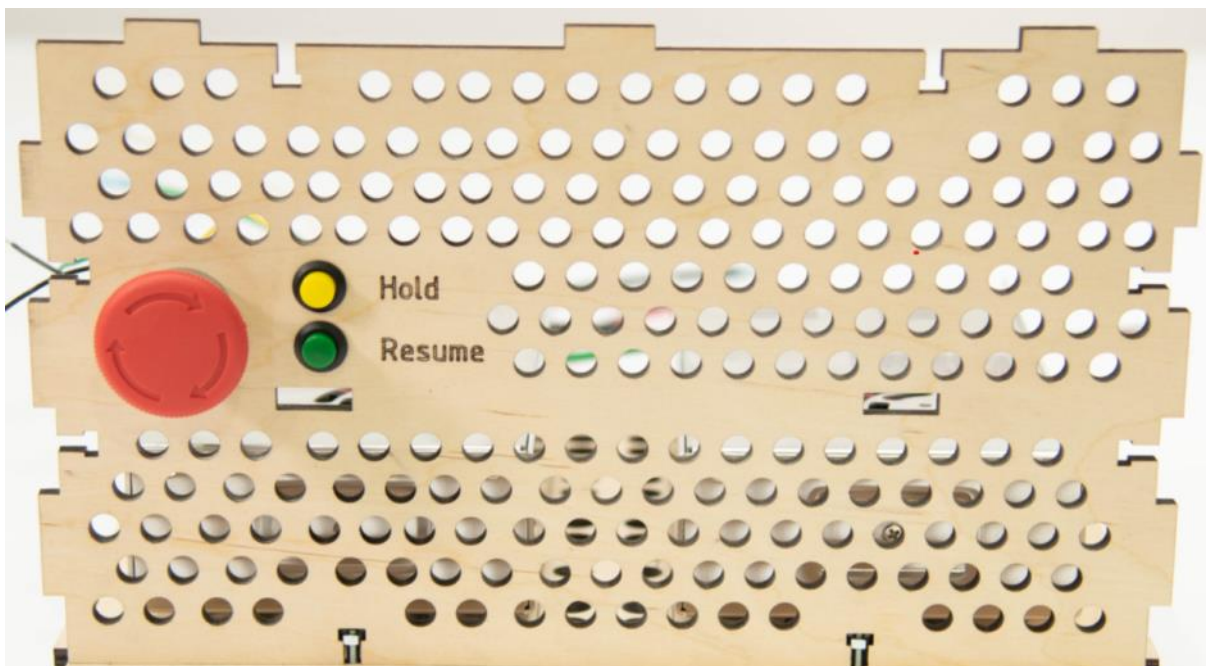

Attaching Power Switch to Left Side Panel

Step 5.0 Attach the Power Switch to the Left Side Panel and secure with two M2.5 x 16 Screws and Nuts.

NOTE: Make sure the switch is on the top with the receptacle on the bottom as shown.

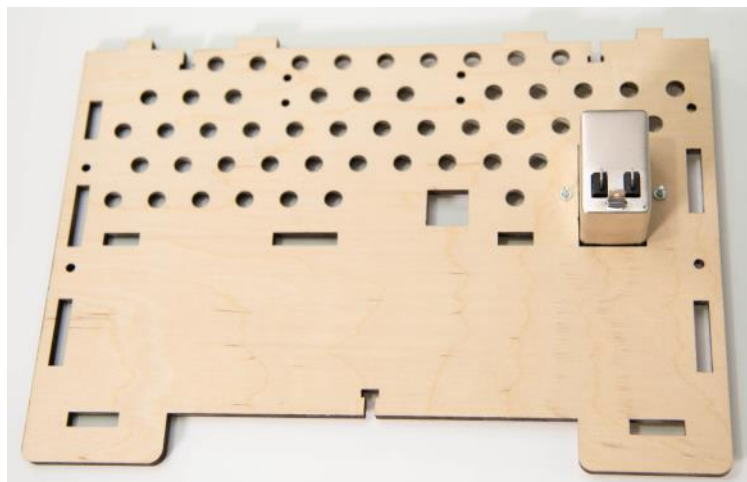
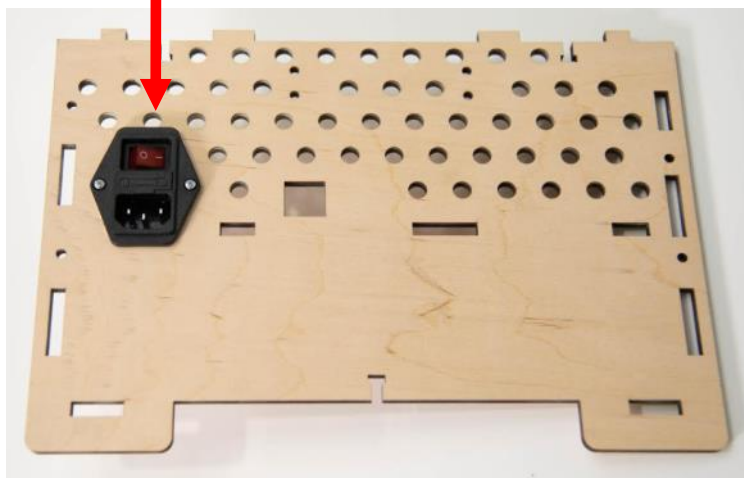
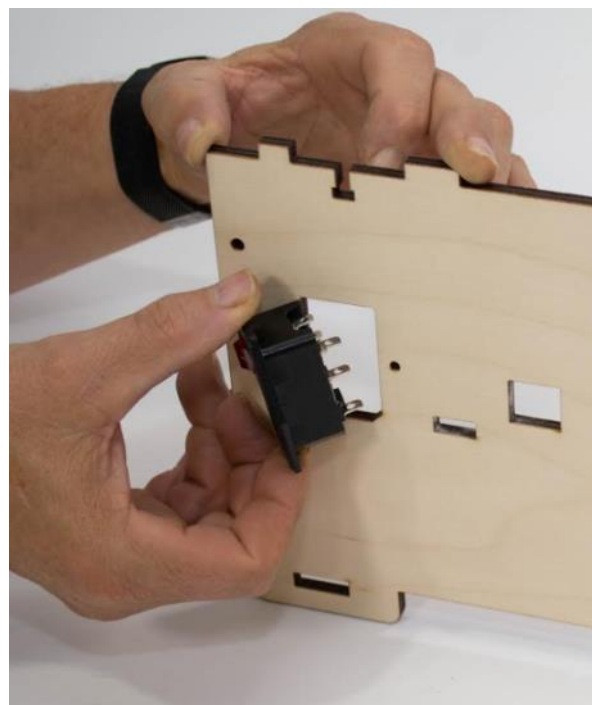

Controller Encloser Assembly

Step 6.0 Attach the C1 Front Panel to the C 7 Bottom Plate and secure with two M4 x 16 Machine Screws and Nuts as shown.

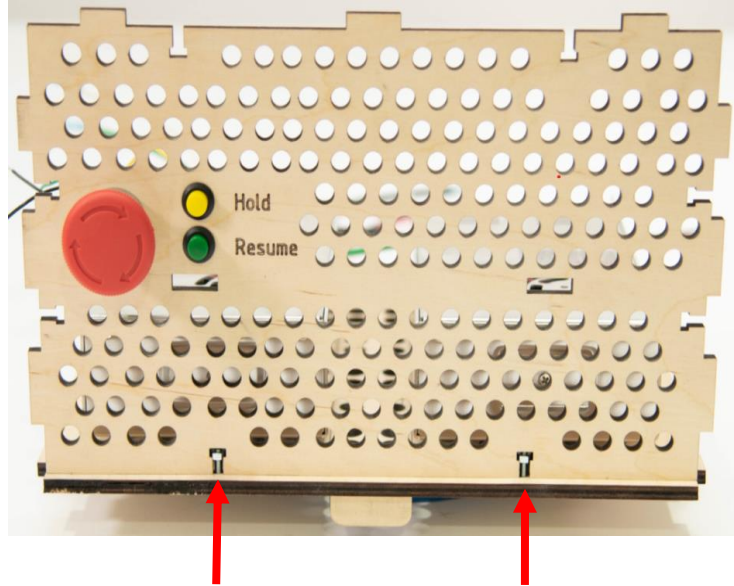
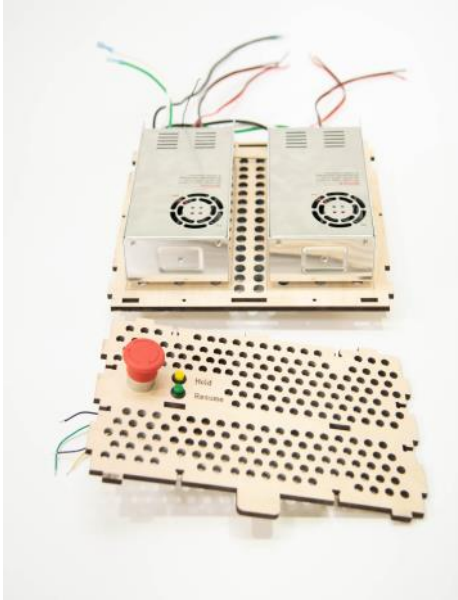

Step 6.1 Attach the C2 Back Panel to the C7 Bottom Plate and secure with two M4 x 16 Machine Screws and Nuts as shown.

NOTE: The Back Panel wire cutout orientation must be as shown.

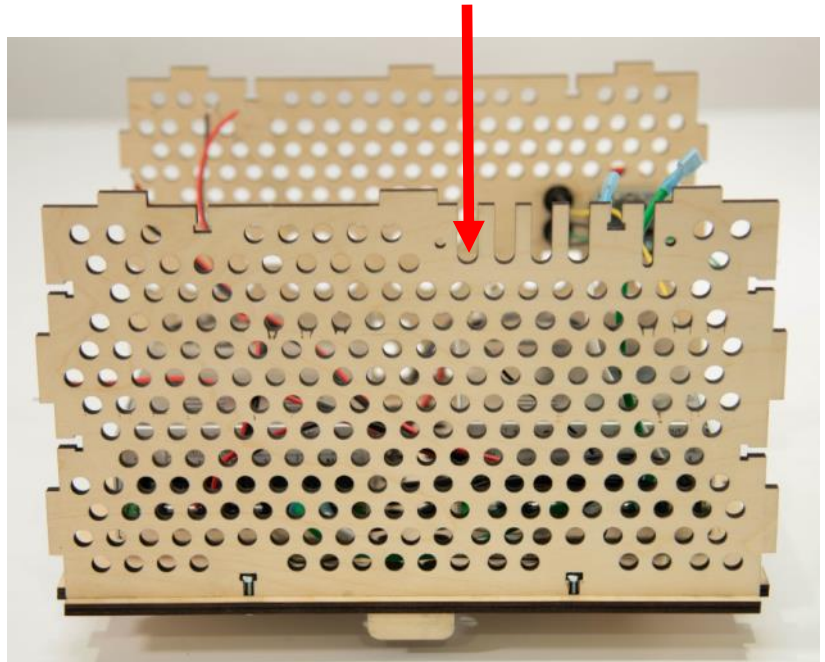
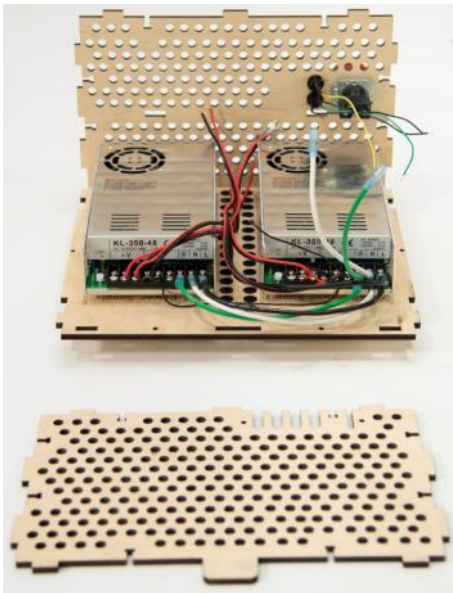

Step 6.2

Align the tabs on the C6 Driver/UNO Shelf to the C1 Front Panel into the corresponding slots and carefully slide into place.

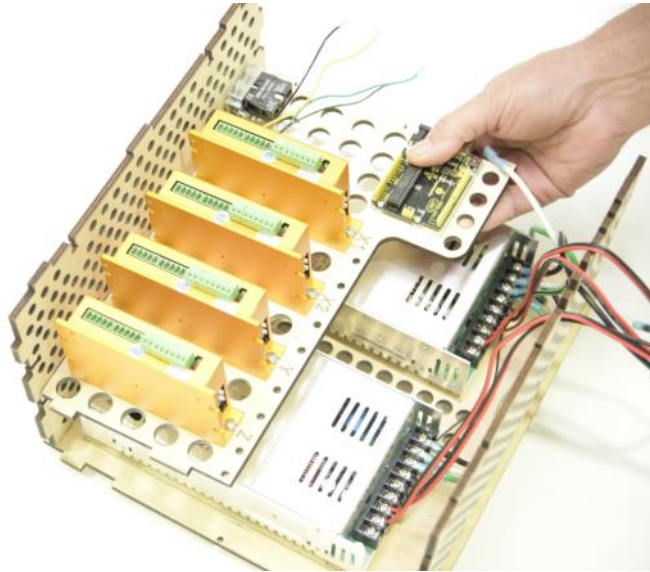

Step 6.3

Turn the Controller Box with the left side down. Align the tabs and slots of the C4 Right Side Panel, Drive Shelf and Bottom Plate and slide into place, then secure with five M4 x 16 Machine Screws and Nuts

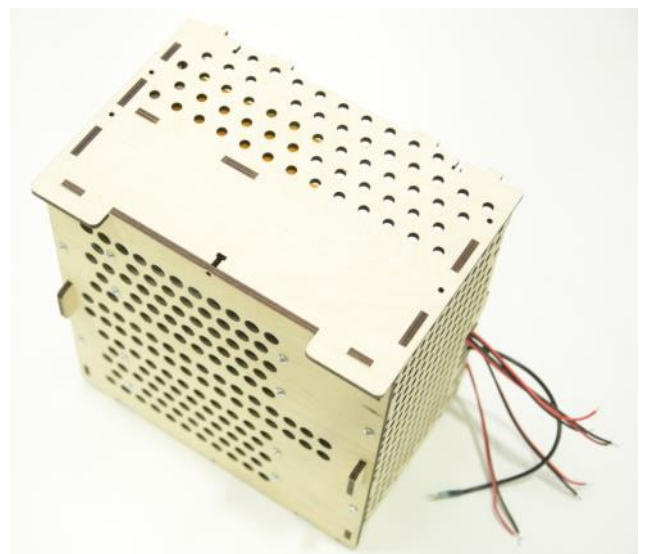
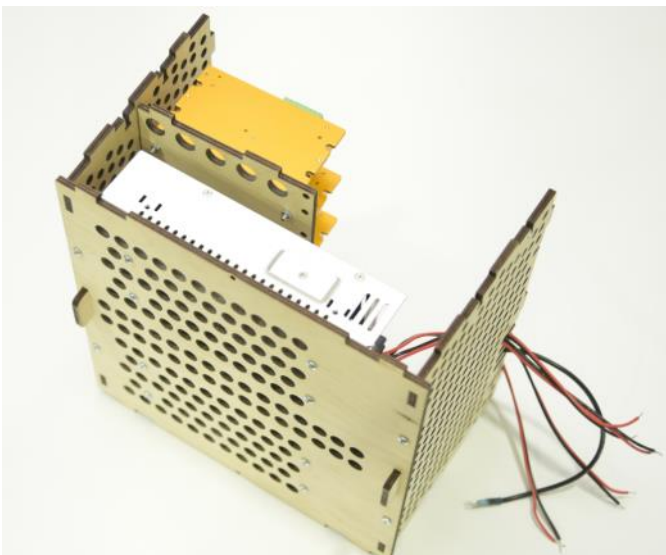

Step 6.4

Repeat the process to attach the C5 Left Side Panel to the Back Panel and Bottom Plate and secure with five M4 x 16 Machine Screws and Nuts as shown below.

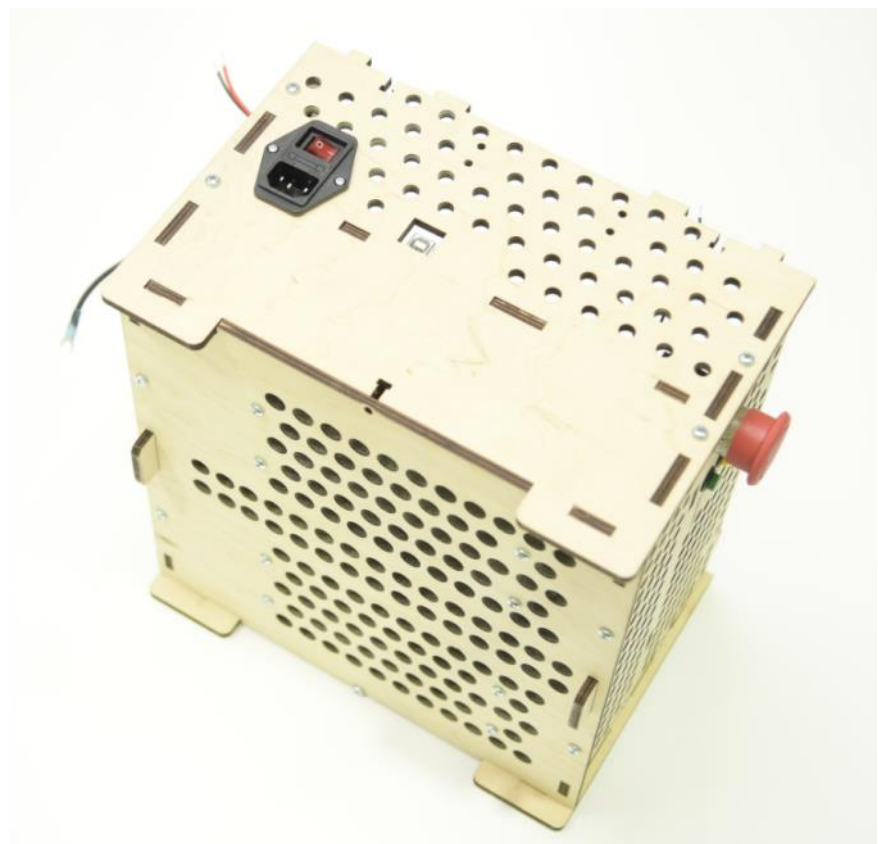
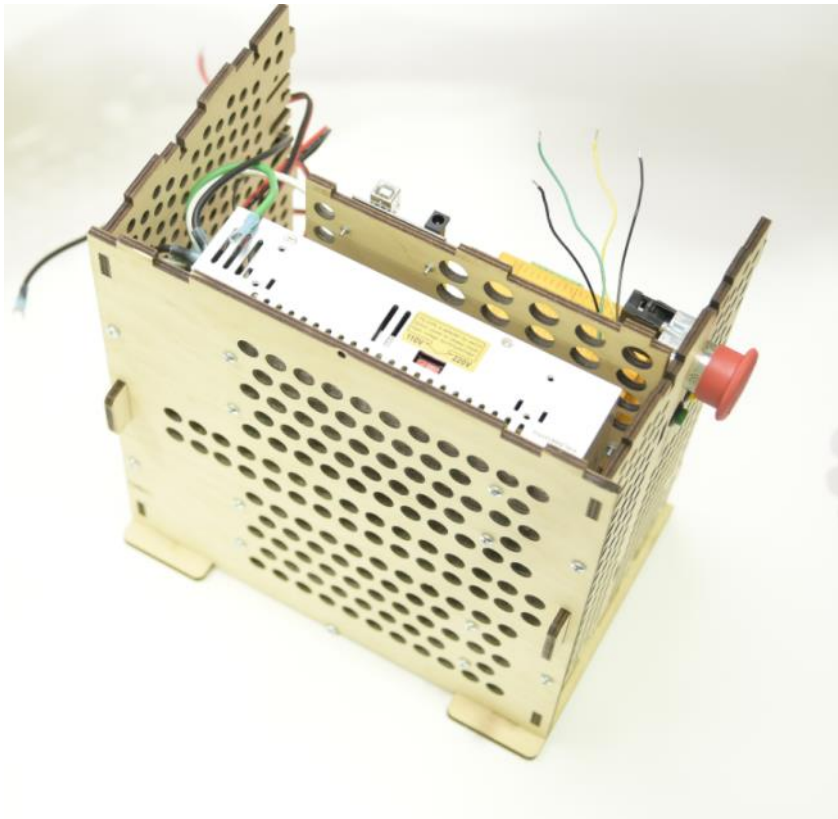

Connecting Power and Emergency Stop Switch

Step 7.0

Connect the #14 Green 140mm AC Ground Female end to Power Supply Switch lower blade as shown.

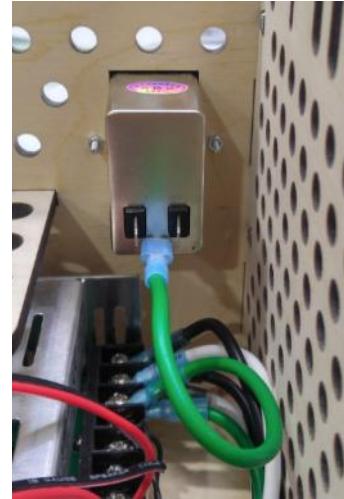

Step 7.1

Connect the 120 V #14 White 140mm AC Neutral Female end to Power Supply Switch right side blade as shown.



Step 7.2

Connect the #14 Black 440mm AC Power wire Female end to Power Supply Switch right side blade as shown. NOTE: this wire has a forked terminal that will be used to connect to the emergency Stop Switch .

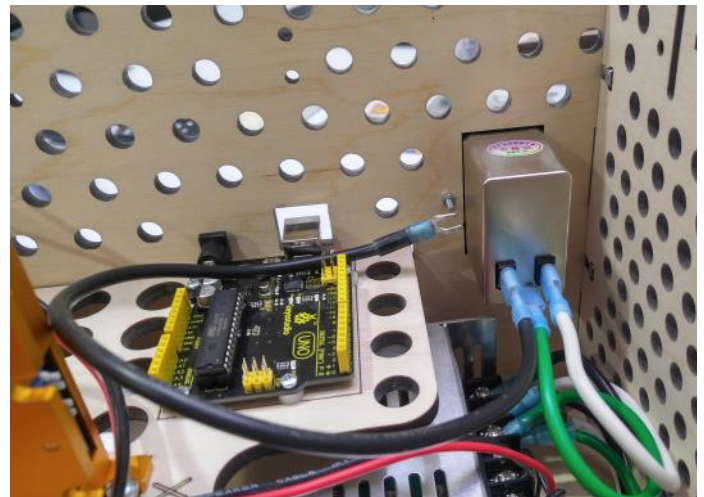

Step 7.3

Separate the plastic terminal block from the Emergency Stop Switch with Phillips screwdriver as shown.

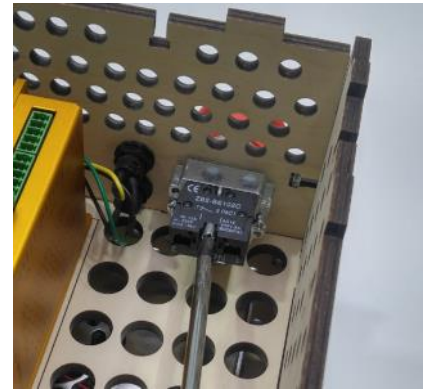

Step 7.4

Attach #14 Black 440 mm AC forked connector from the Power Switch to the Emergency Stop Terminal Block as shown.

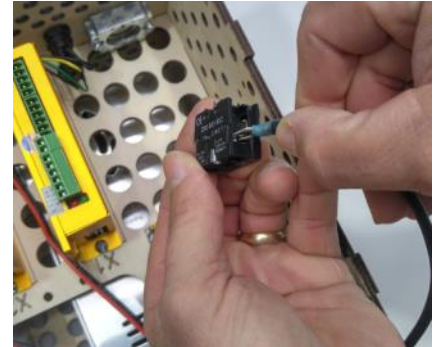

Step 7.5

Attach #14 Black 440 mm AC forked connector on the Power Supply to the terminal block as shown.

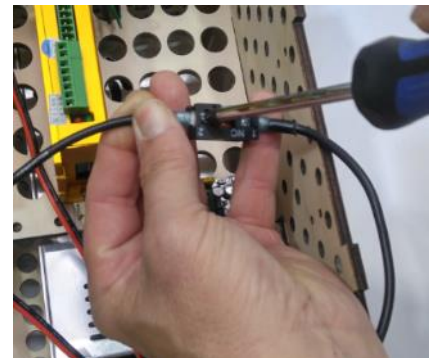

Step 7.6

Reattach terminal block to Emergency Stop Switch by inserting and re-tightening screw.



Step 7.7

Secure the #14 black wires to the Back Panel with two Zip Ties and shown below.

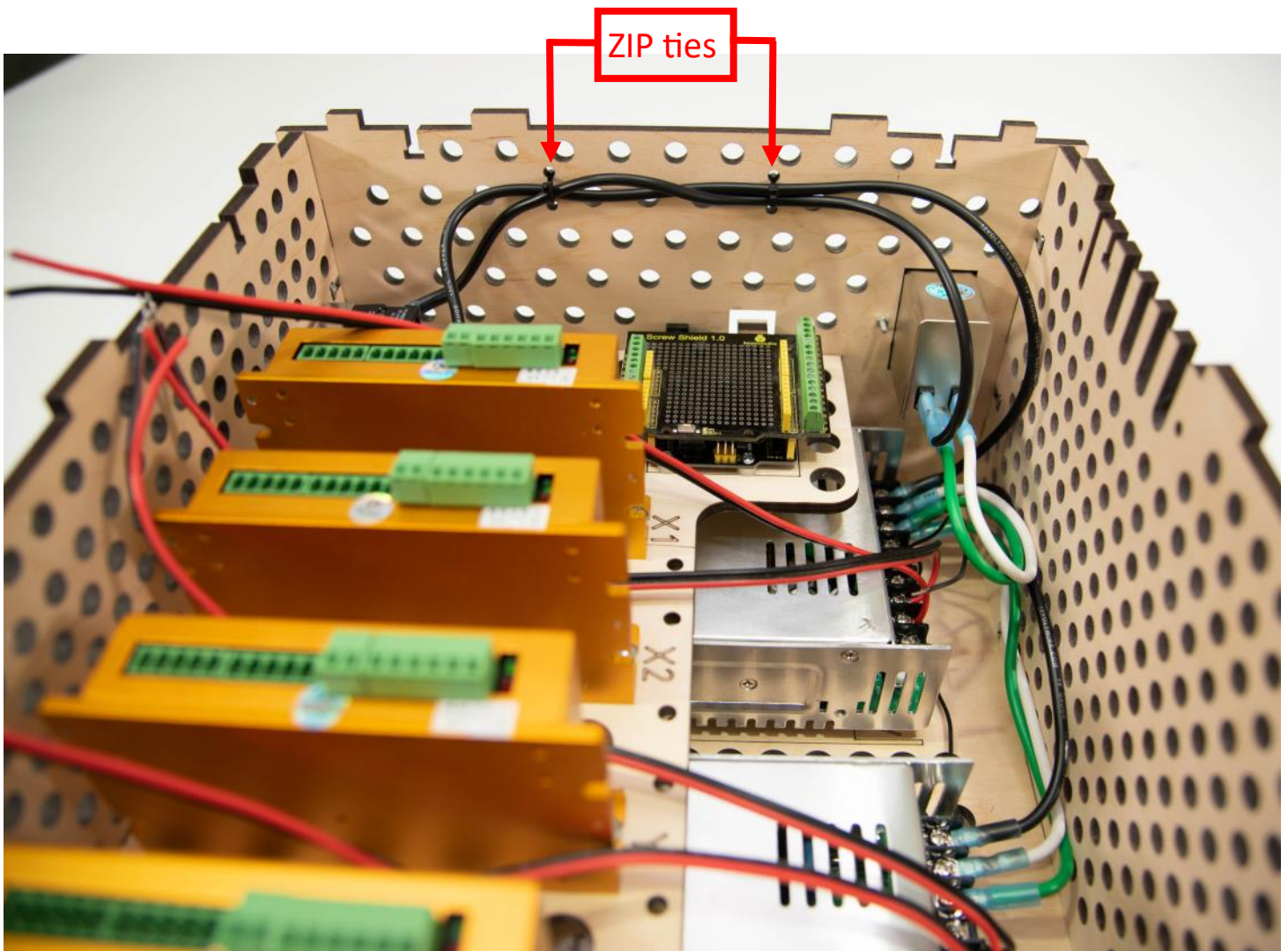

Installing Screw Shield and Connecting Control Wires

Step 8.0 Carefully fit the pins of the Screw Shield into the UNO Controller sockets ensuring the rearward pins and sockets match as shown.

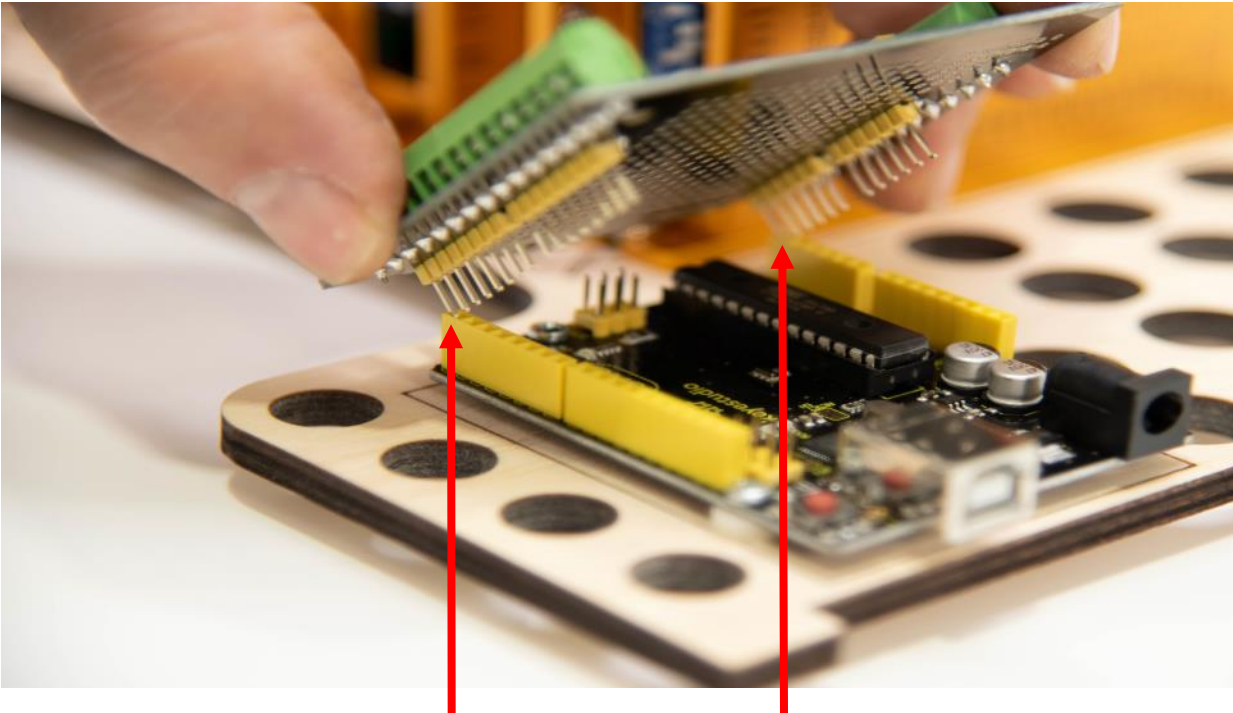

Align rearward pins and sockets (labeled A5 and D0).

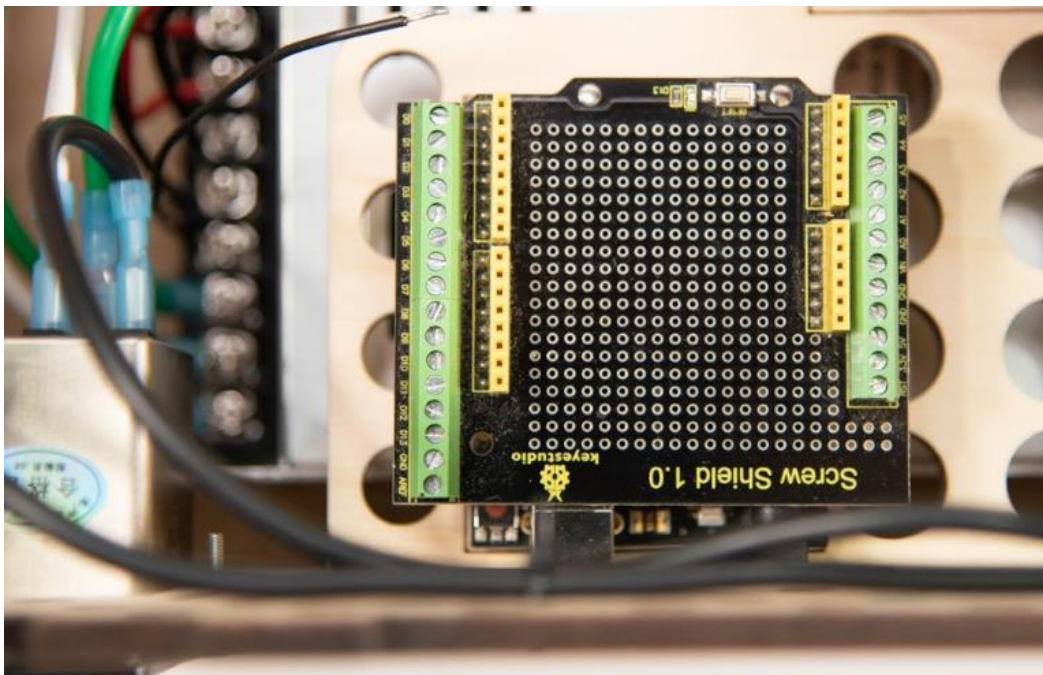

Step 8.1

Attach #22 Black 130 mm DC Ground Wire from the Power Supply to the GND on the Screw Shield as shown below.

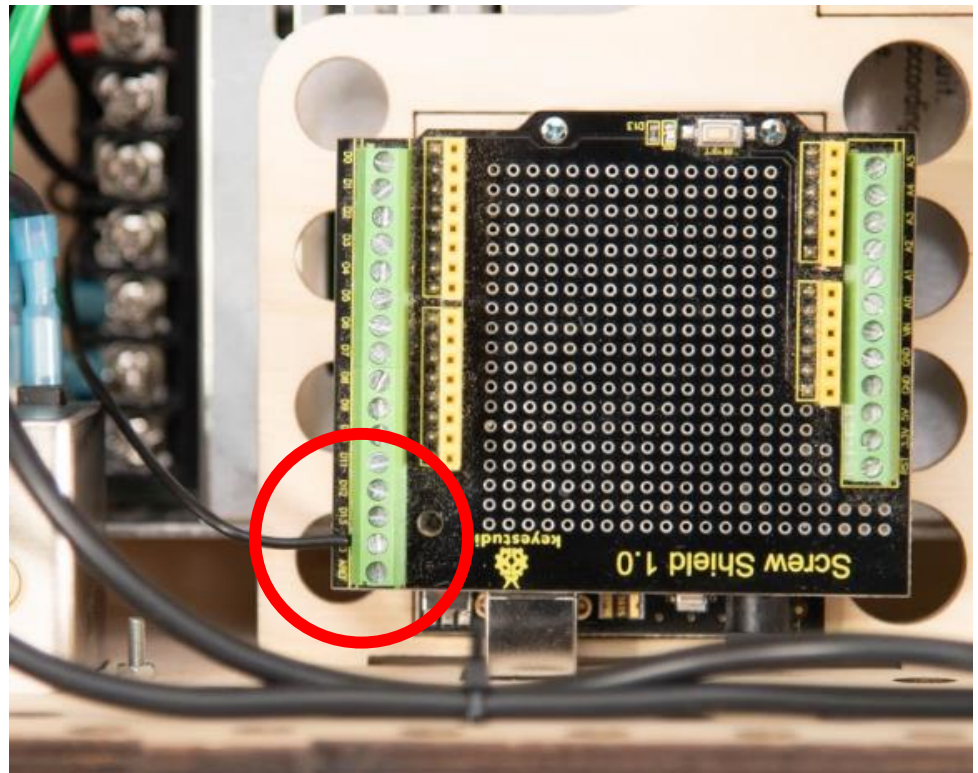
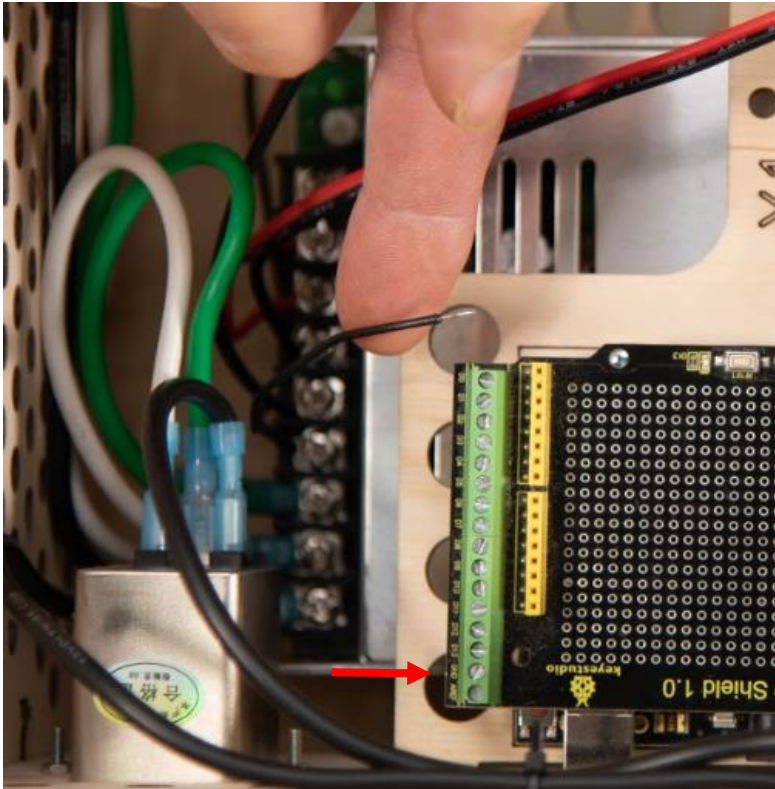

Step 8.2

Using the #22 black 40mm jumpers, connect driver pins 2 and 4, as shown.



Step 8.3

Using the #22 black 40mm jumpers connect driver pins 4 and 8 as shown.



Step 8.4

Insert one #22 black 80mm jumper in pin number 8 as shown. NOTE: The other end of the wire will be connected in a later step.

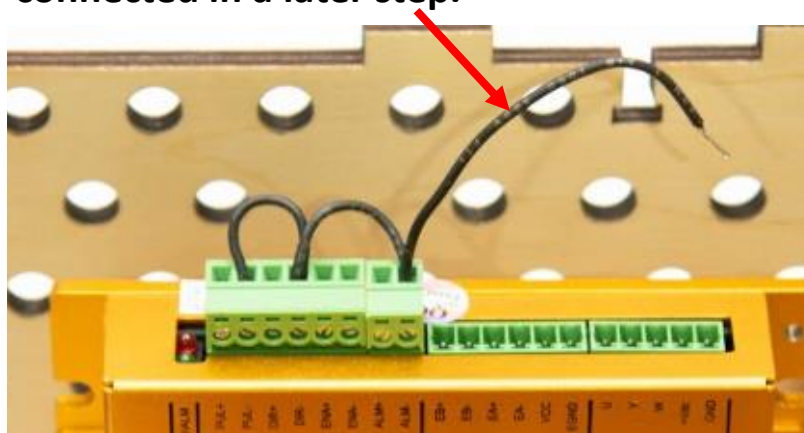

Step 8.5

Repeat for all four Drivers as shown.

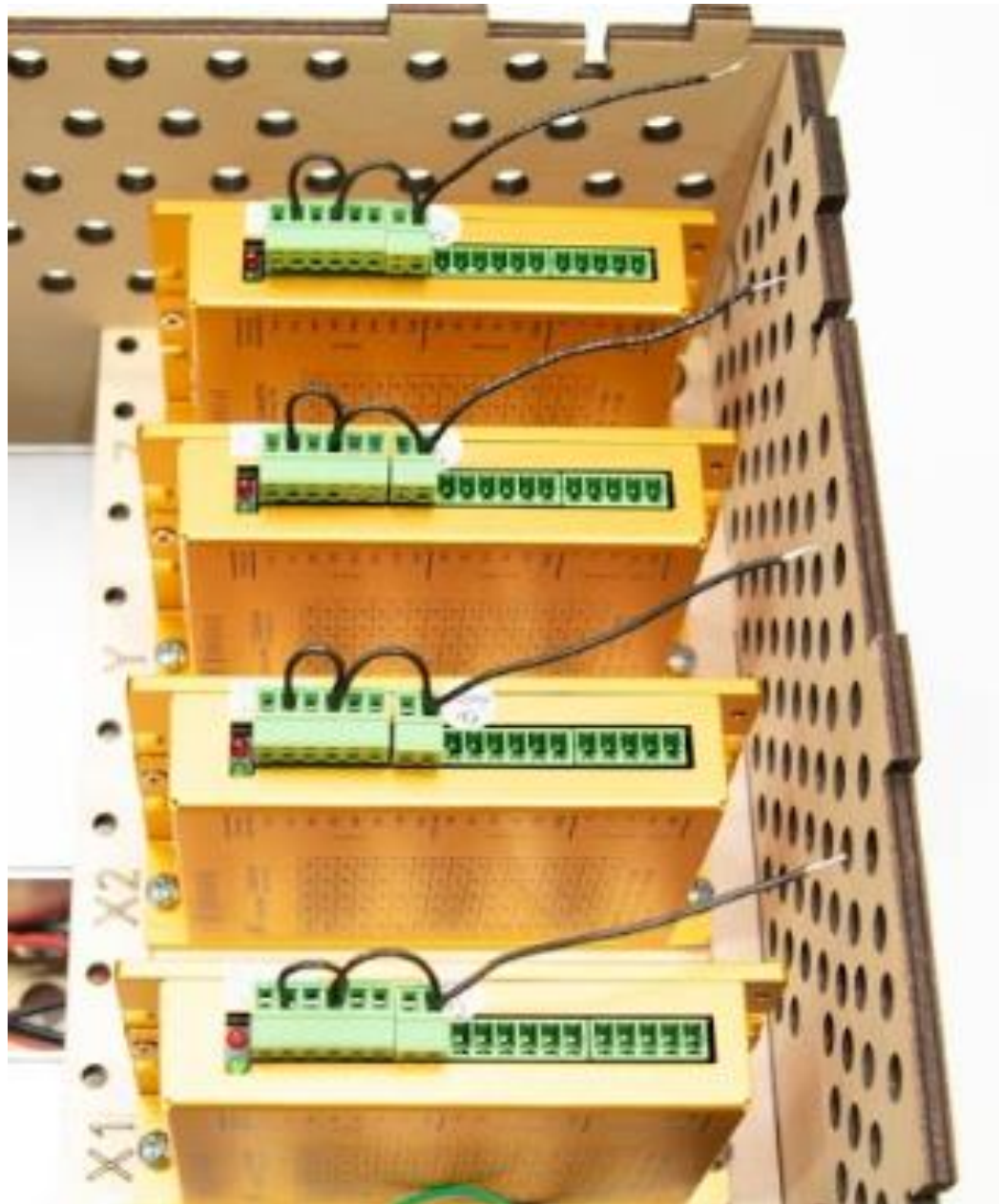

Step 8.6

Attach the two black Hold and Resume Switch wires to the “GND” terminal as shown.

Attach the Yellow “Hold” wire to the number 5 (A1) Screw Shield terminal and the Green “Resume” wire to the number 4 (A2) terminal as shown.

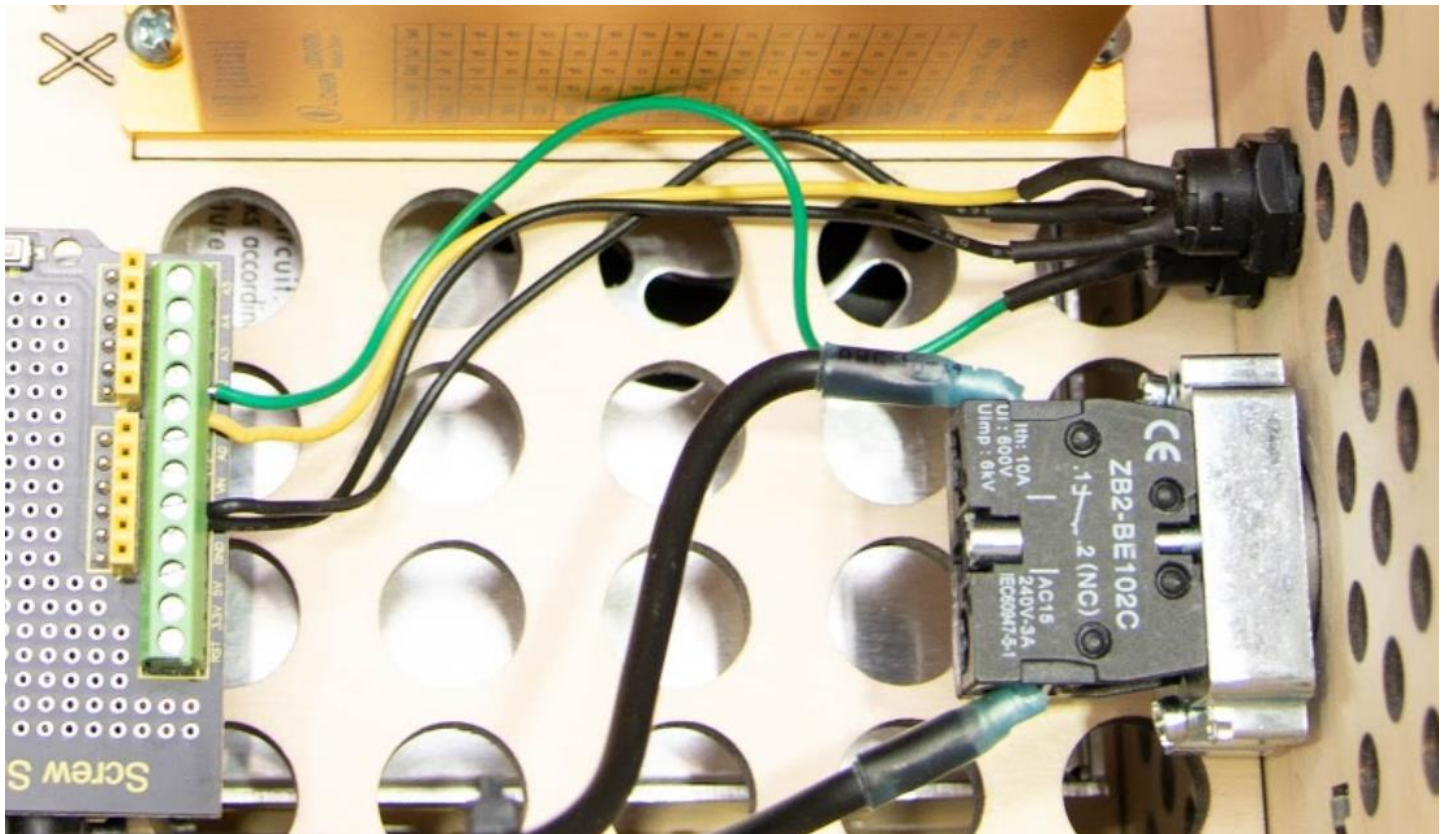

Step 8.7

Daisy-chain the four Drivers using the #22 red 80mm wires by connecting to the number 7 screw terminal (ALM+) as shown below.

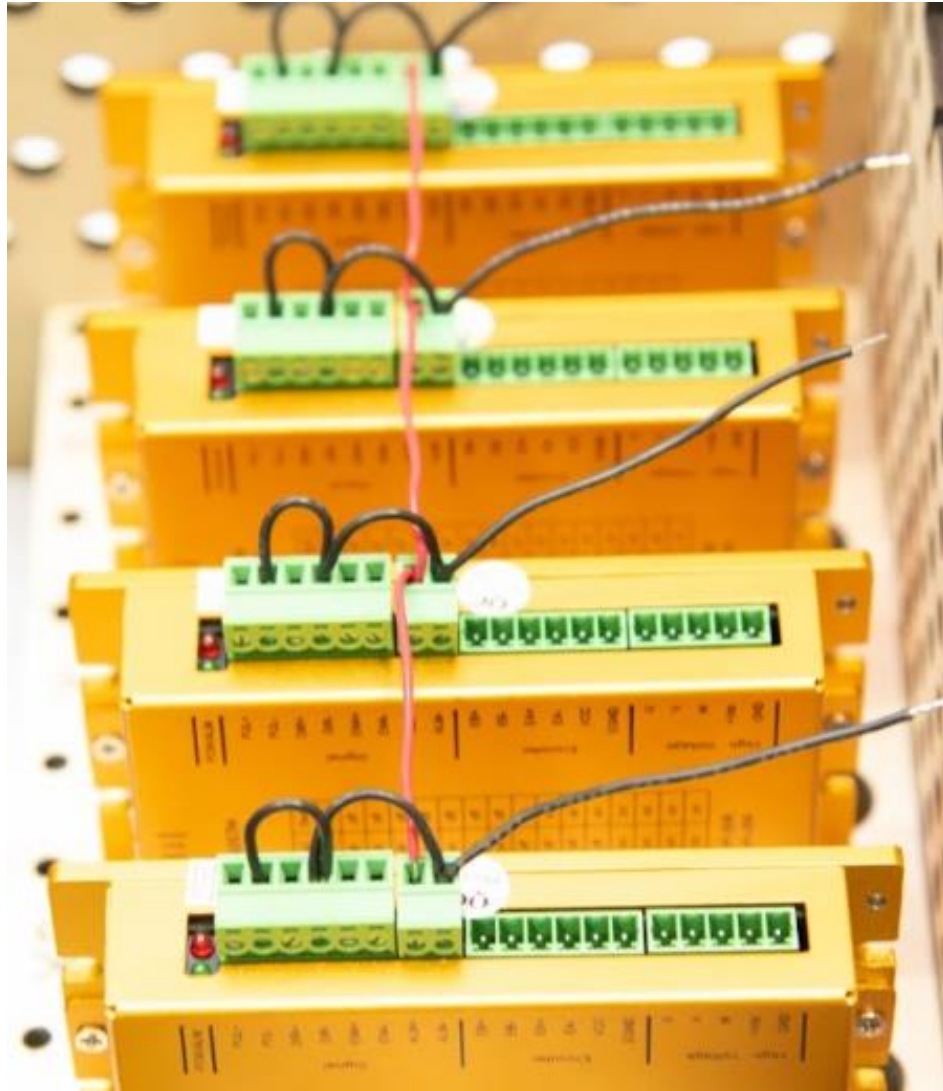

Step 8.8

Connect the #22 red 180mm alarm wire with the ferrite coil to the number 7 screw terminal of the X1 Driver. Connect the other end to the A0 Terminal on the Screw Shield as shown.

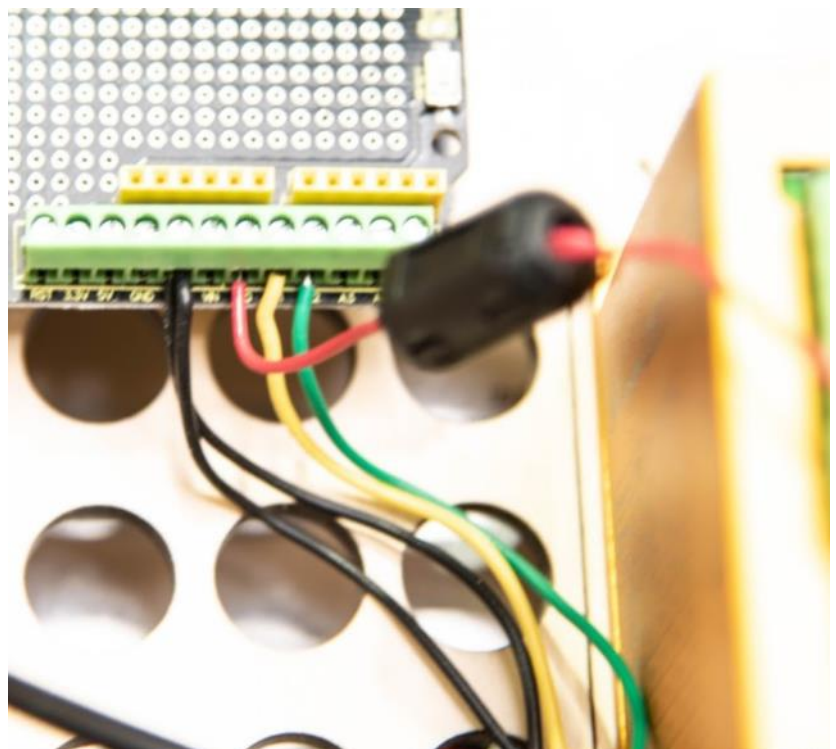
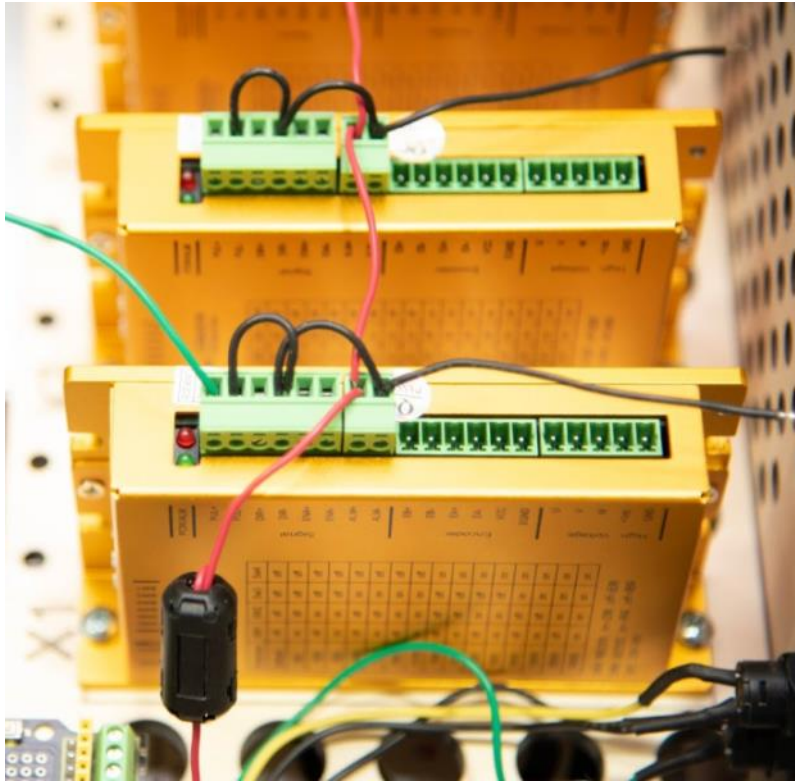

Step 8.9

Attach the #22 Green 160mm wire from the number 1 (PL+) screw terminal on the X1 driver to the D2 terminal on the Screw Shield as shown.

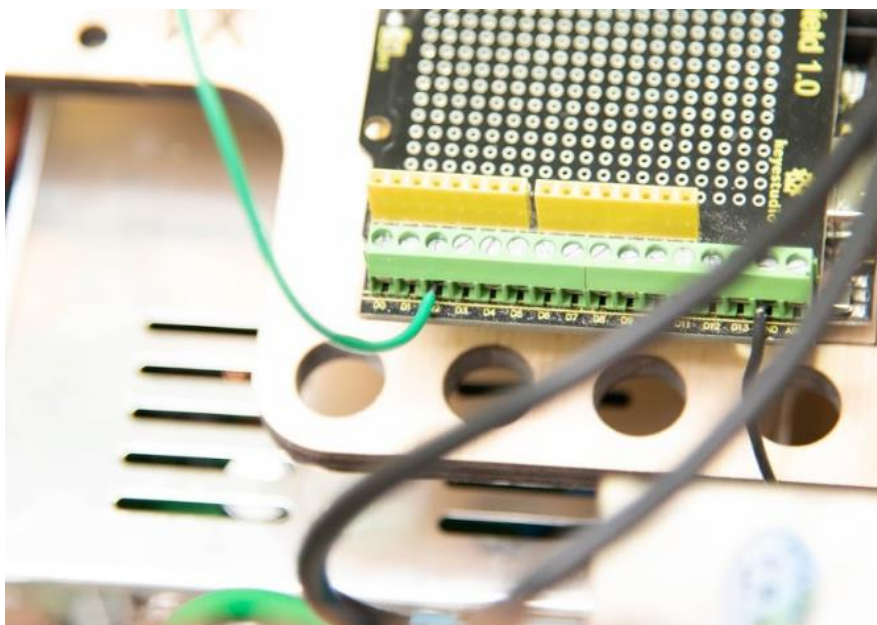
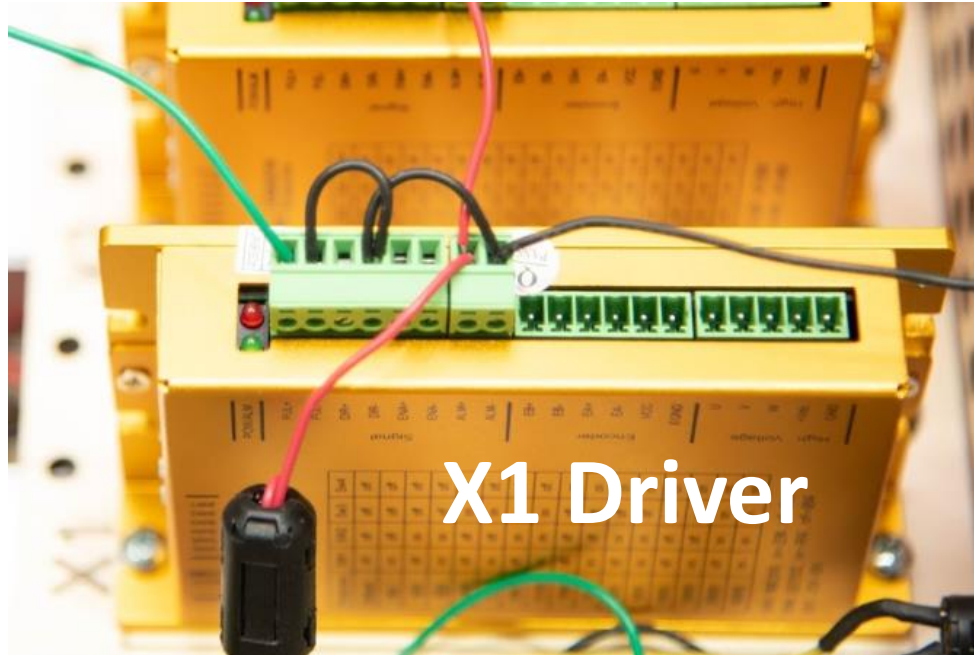

Step 8.10 Attach the #22 Brown 160mm wire from the number 1 (PL+) screw terminal on the X2 driver to the A4 terminal on the Screw Shield as shown.

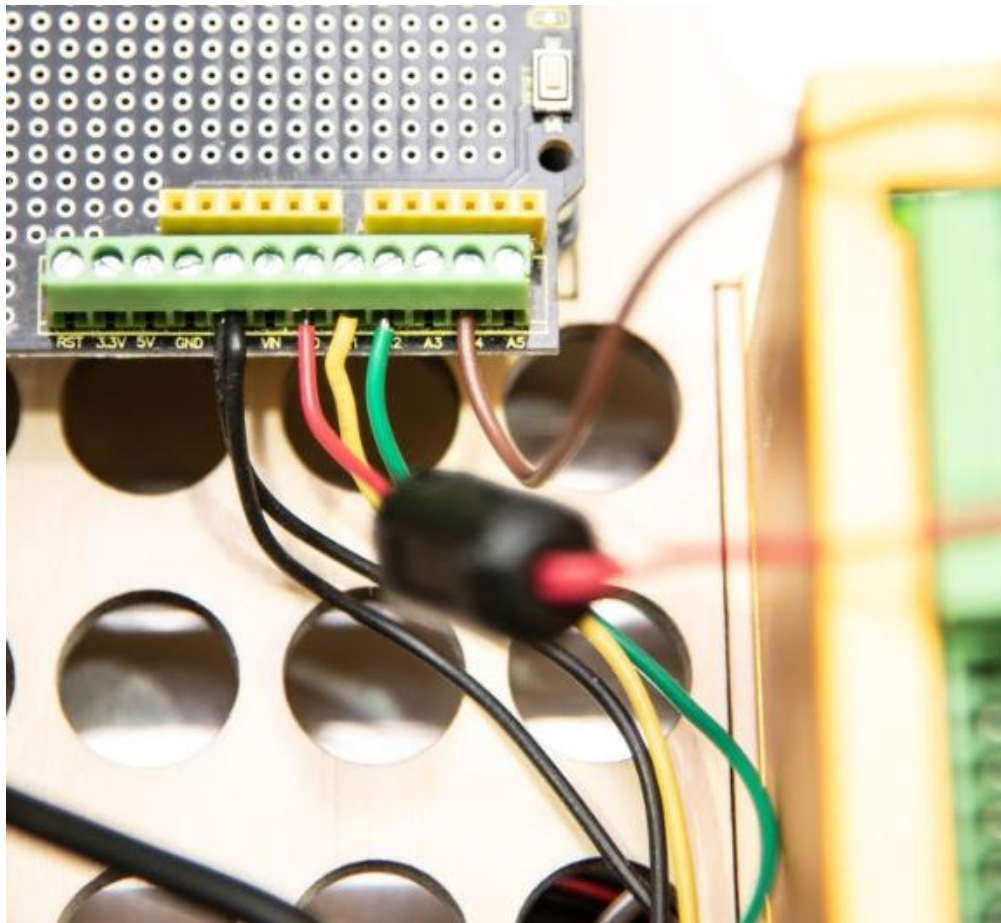
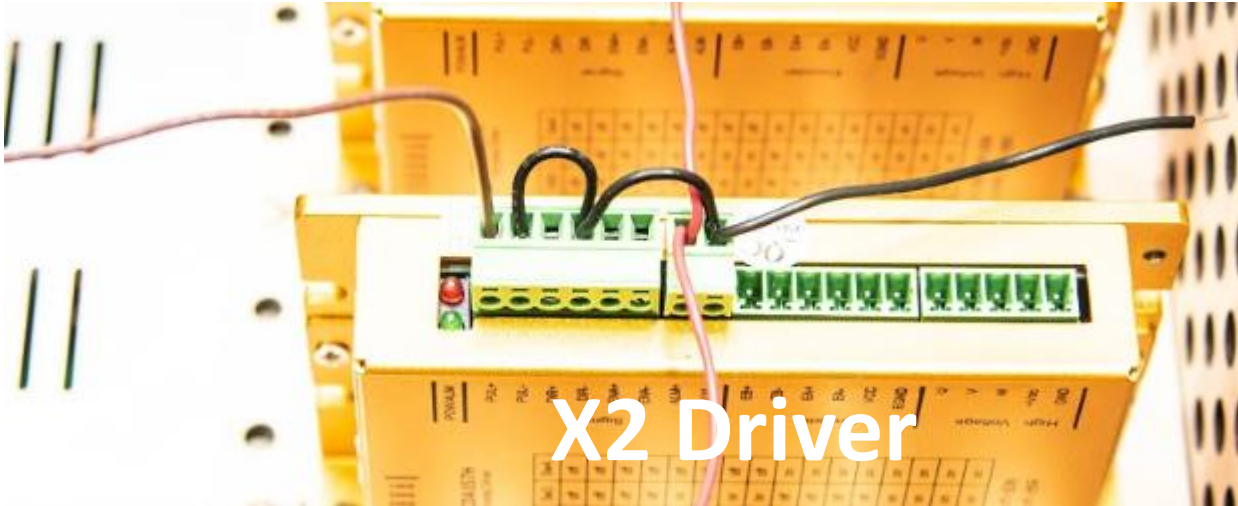

Step 8.11 Attach the #22 Orange 250mm wire from the number 1 (PL+) screw terminal on the Y Driver to the D3 terminal on the Screw Shield as shown.

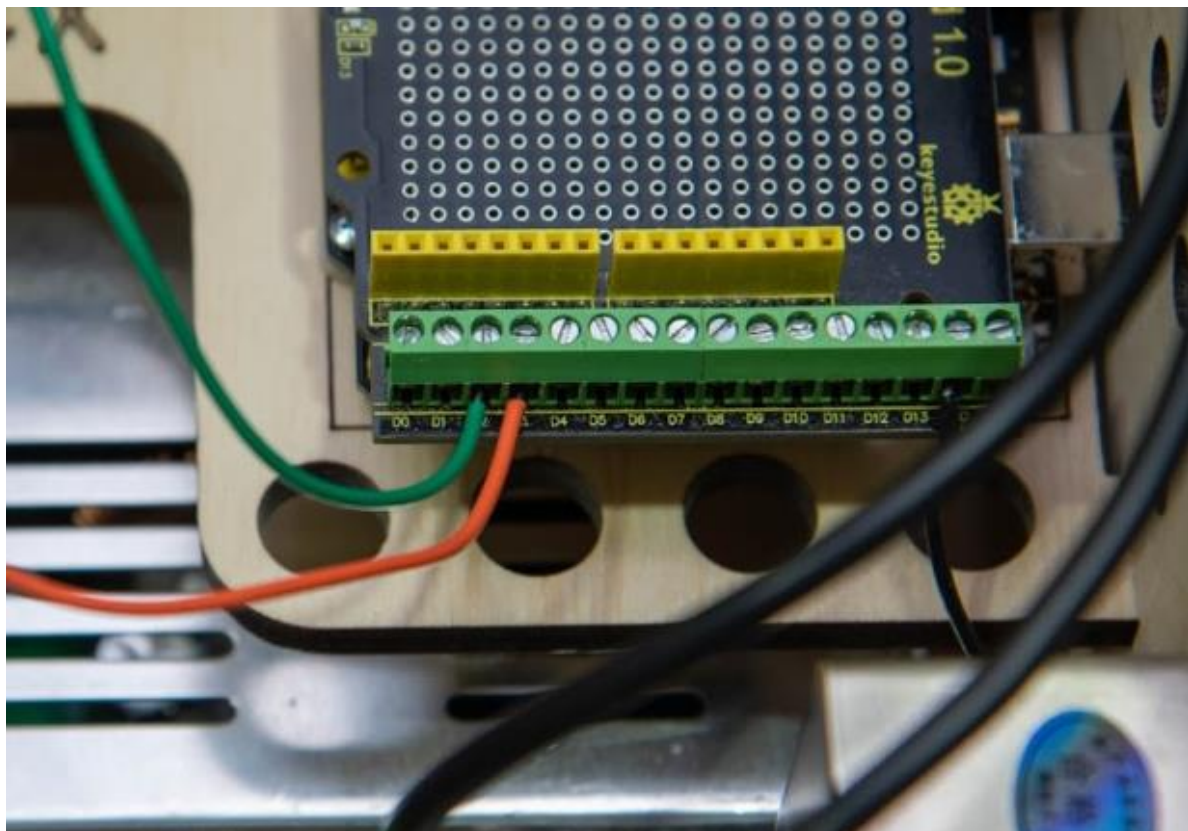
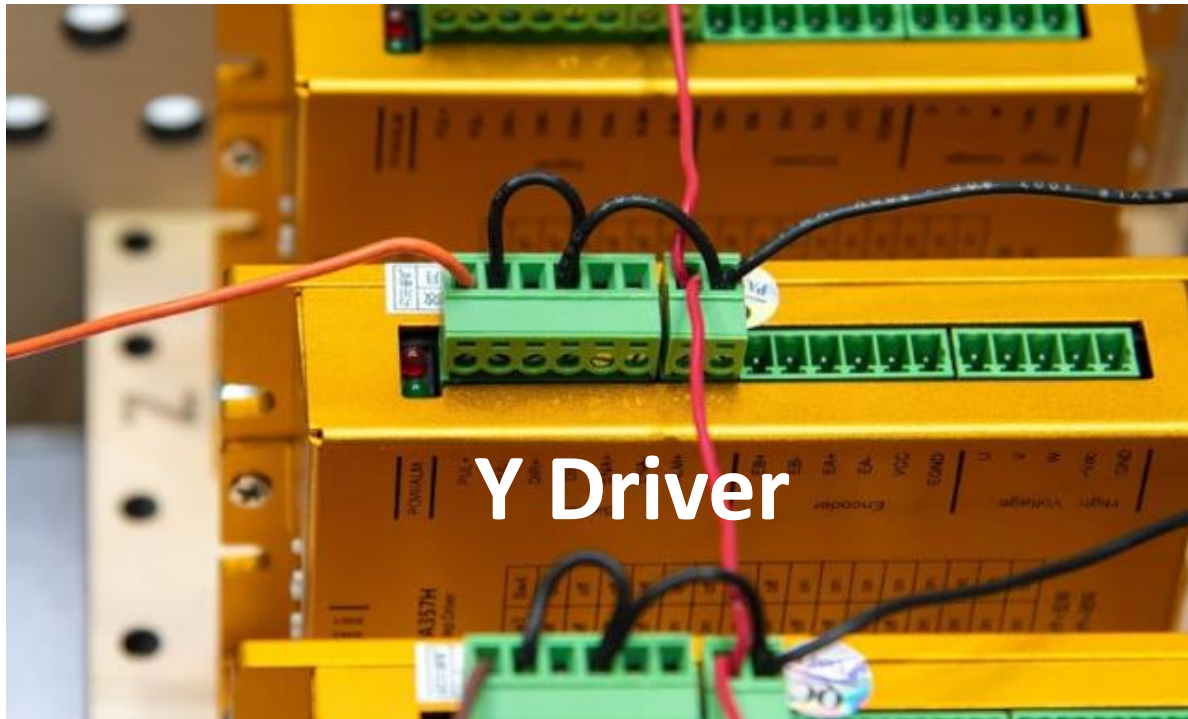

Step 8.12 Attach the #22 White 320mm wire from the number 1 (PL+) screw terminal on the Z Driver to the D4 terminal on the Screw Shield as shown.

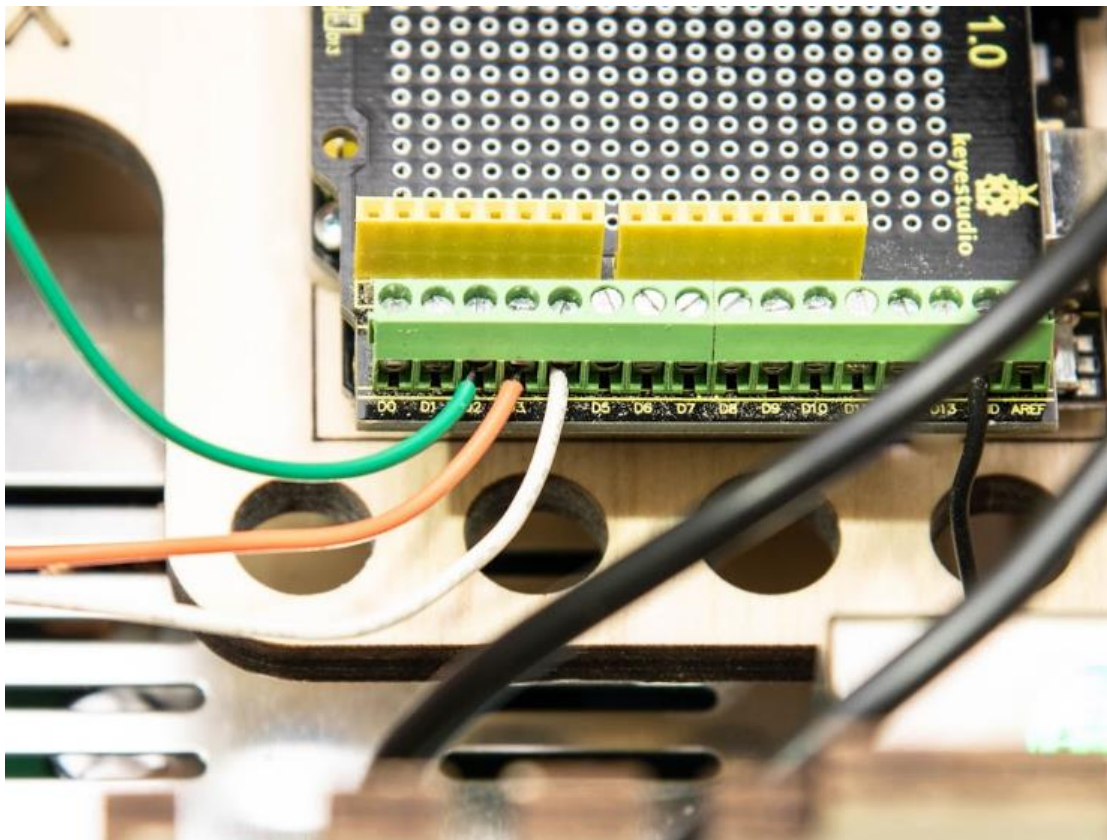
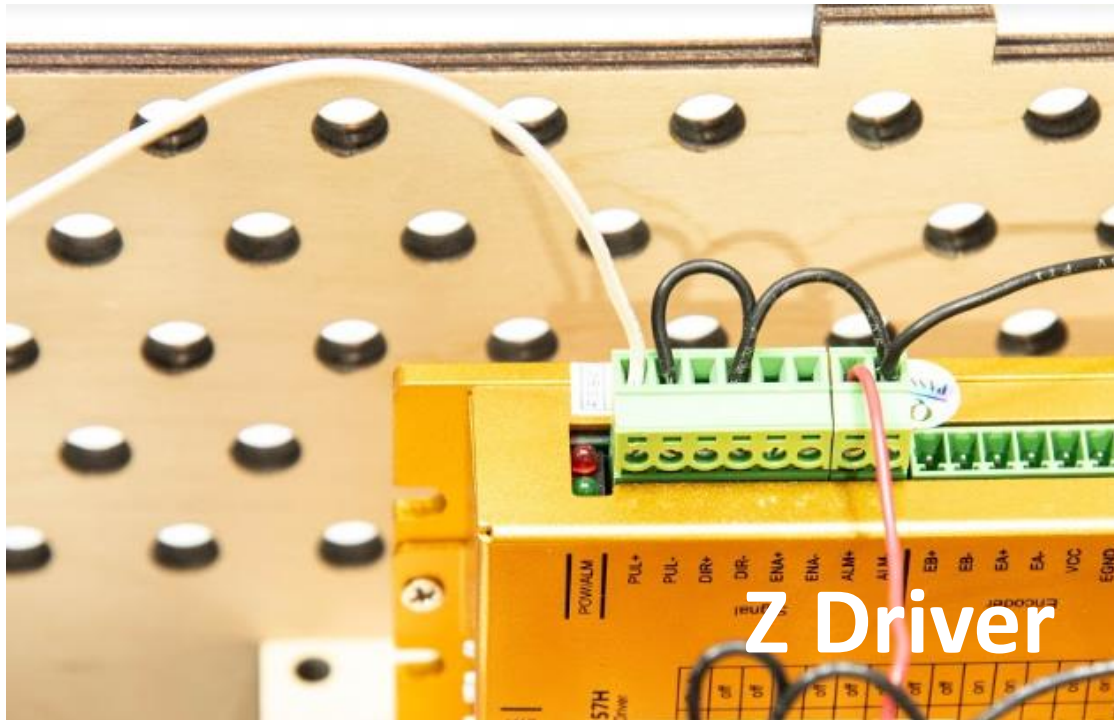

Step 8.13

Attach the #22 Yellow 160mm wire from the number 3 (DIR+) screw terminal on the X1 Driver to the D5 terminal on the Screw Shield as shown.

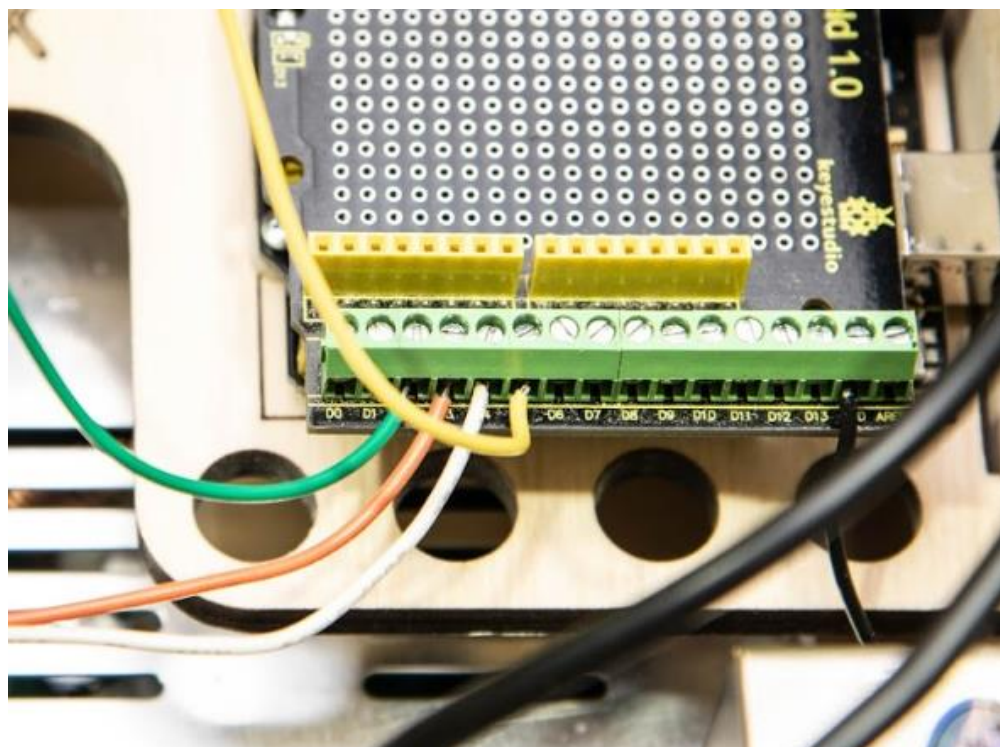
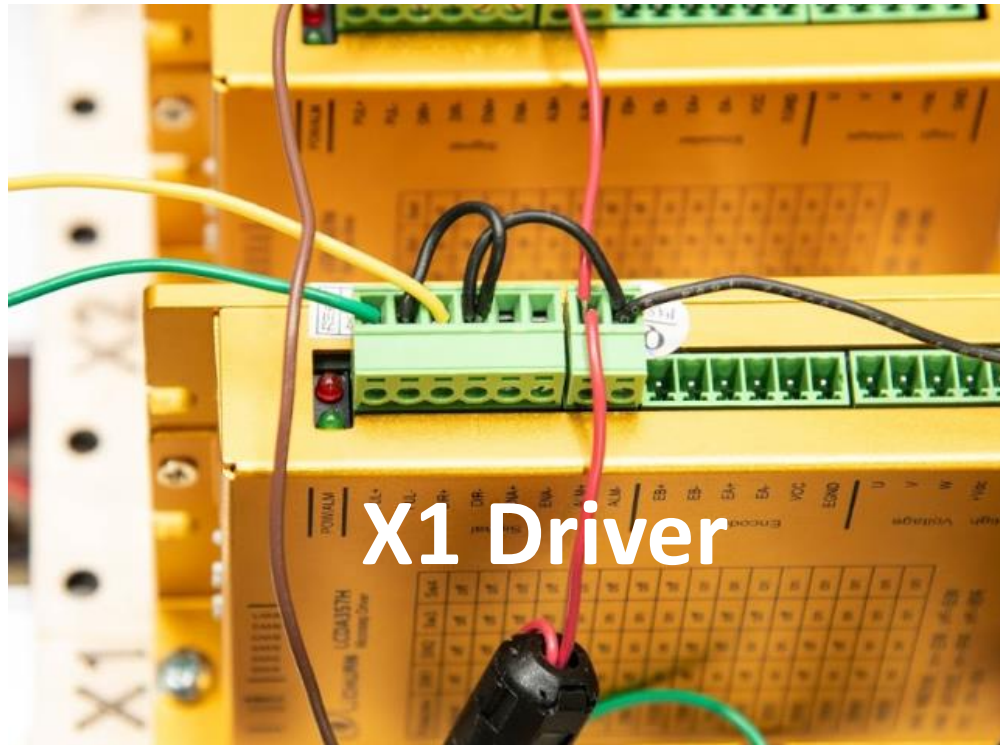

Step 8.14 Attach the #22 Gray 160mm wire from the number 3 (DIR+) screw terminal on the X2 Driver to the A3 terminal on the Screw Shield as shown.

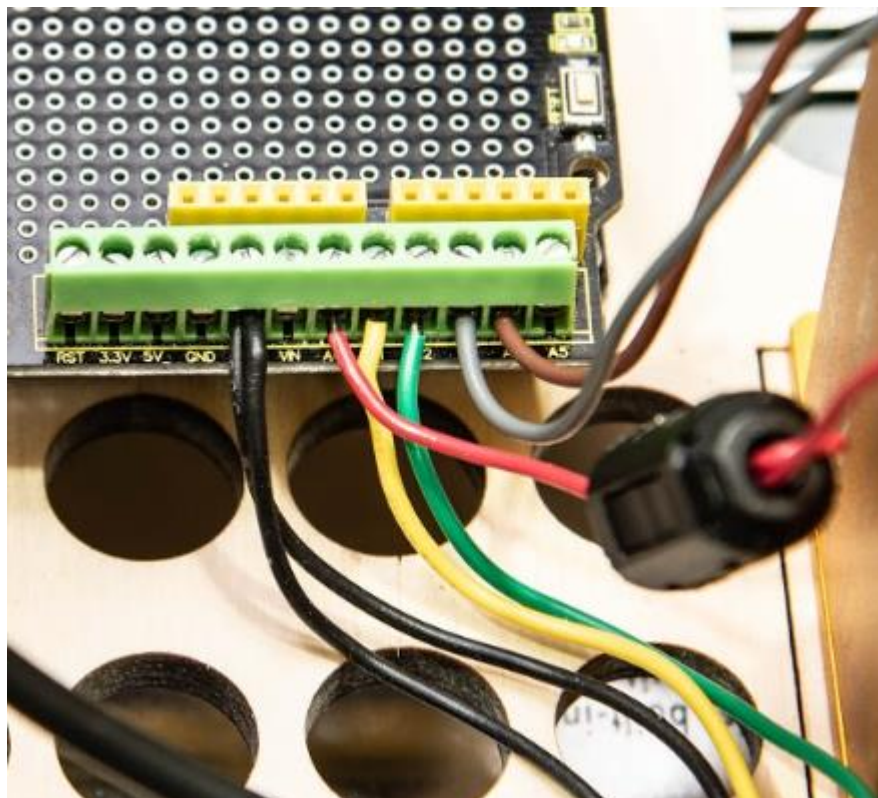
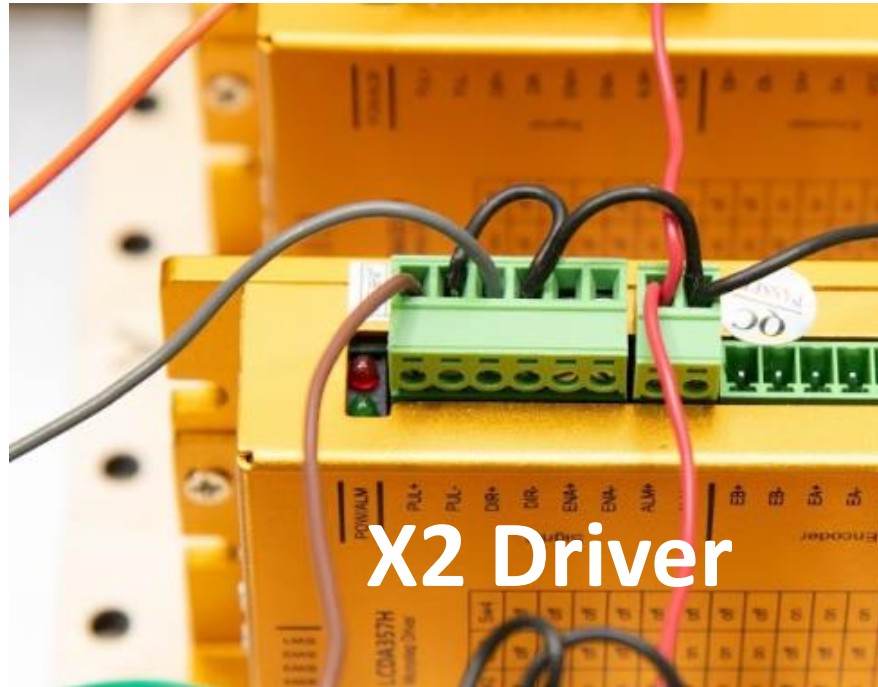

Step 8.15 Attach the #22 Blue 250mm wire from the number 3 (DIR+) screw terminal on the Y Driver to the D6 terminal on the Screw Shield as shown.

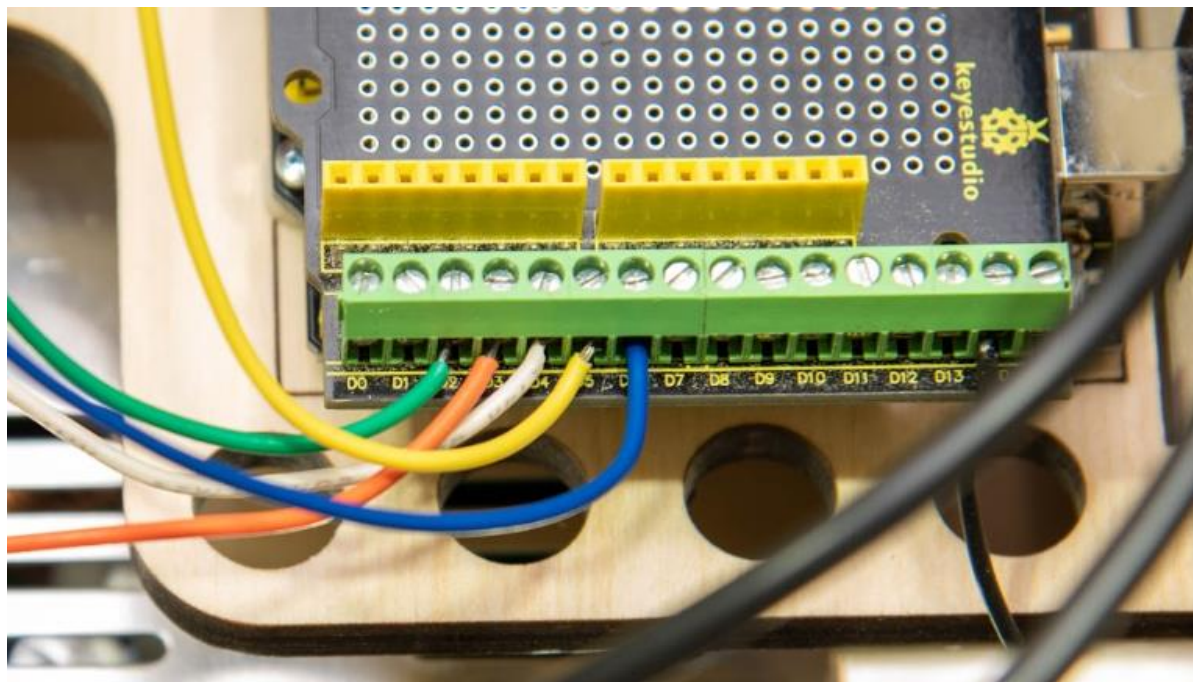
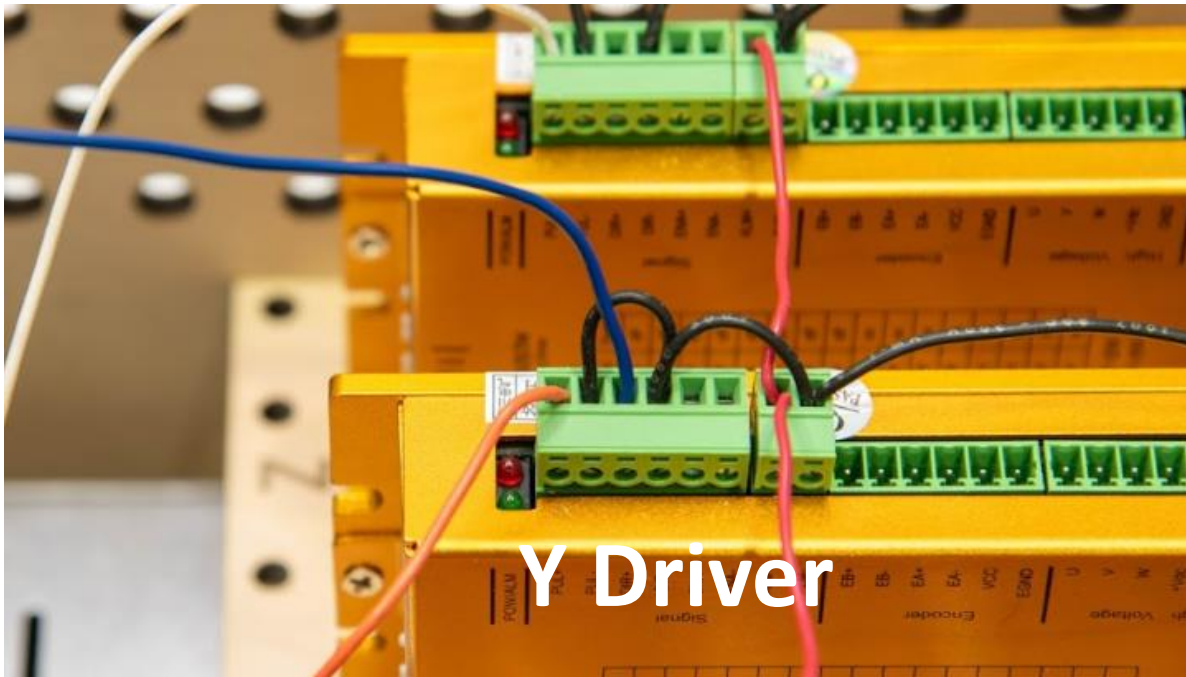

Step 8.16 Attach the #22 Purple 320mm wire from the number 3 (DIR+) screw terminal on the Z Driver to the D7 terminal on the Screw Shield as shown.

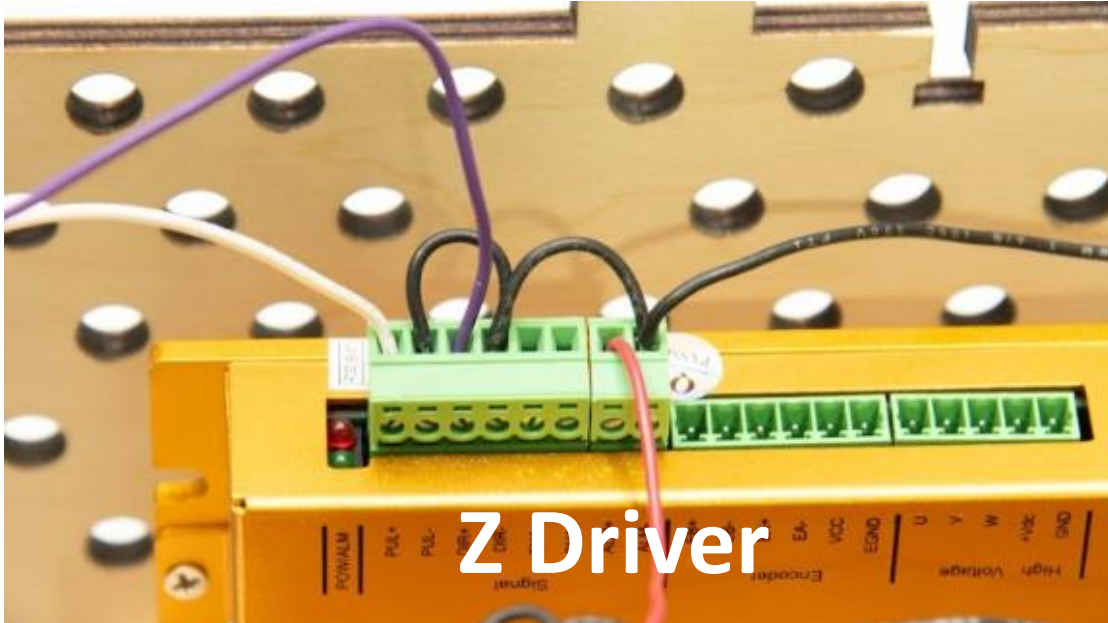

Step 8.17 Neatly Zip Tie the control wires as shown

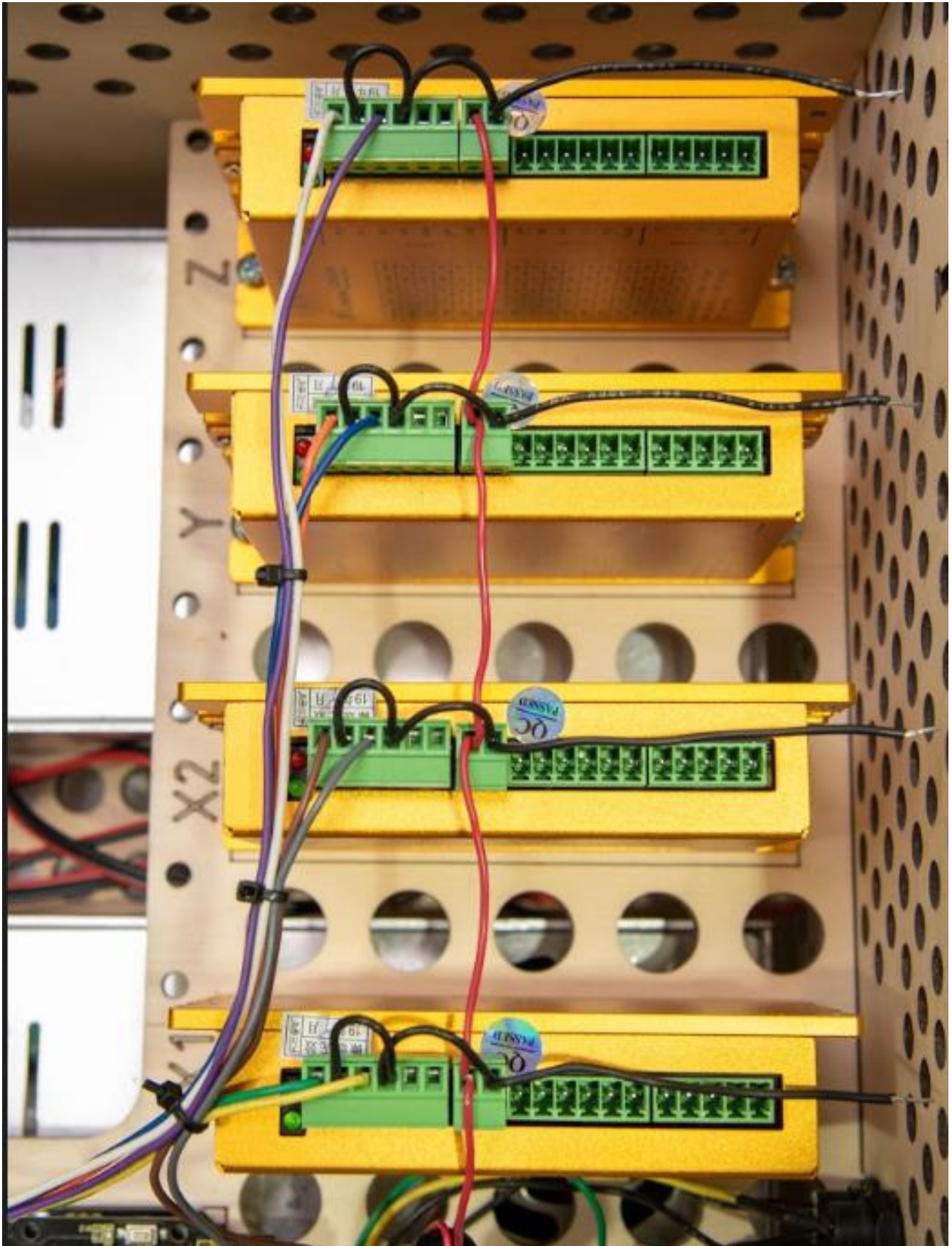

Connecting the Home Switches

Step 1 Label and lay out the Home Switch Cables and remove outer sheathing from each Cable to expose 4 inches of the wires within. Repeat for the remaining Home Switch Cables.

NOTE: The Home Switches are cut to the same length as the Servo Motor Cables.

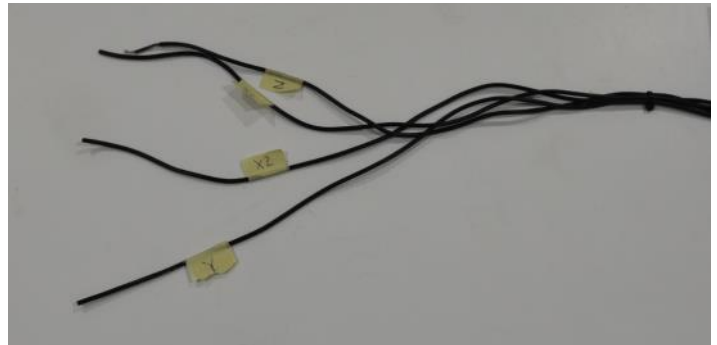

Slice the sheathing 1/4 from the edge.



Pull the sheathing back 4 inches, then remove and discard the removed sheathing.

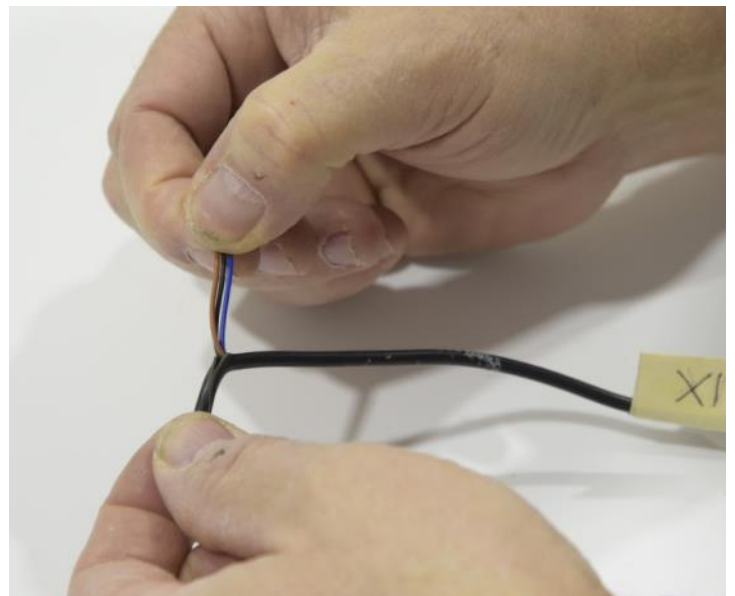

Step 2

Trim each of the wires, leaving exposed wire lengths as shown in the table.

Description	Exposed length
Brown and Blue wires	1/2 inch
Black X2 and Z wires	1/2 inch
Black X1 and Y wires	3/16 inch

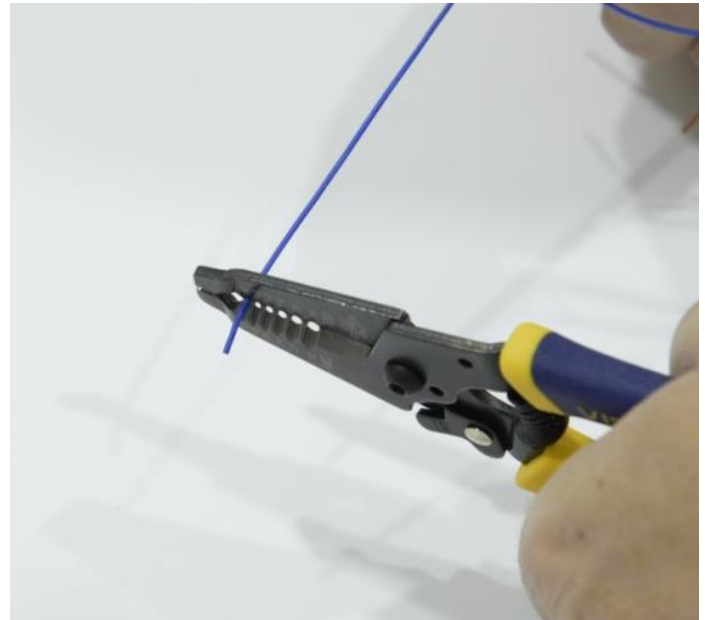

Step 3

Repeat for all four of the Home Switch Cables.



Step 4

Align all 4 blue wires and twist them together as shown.

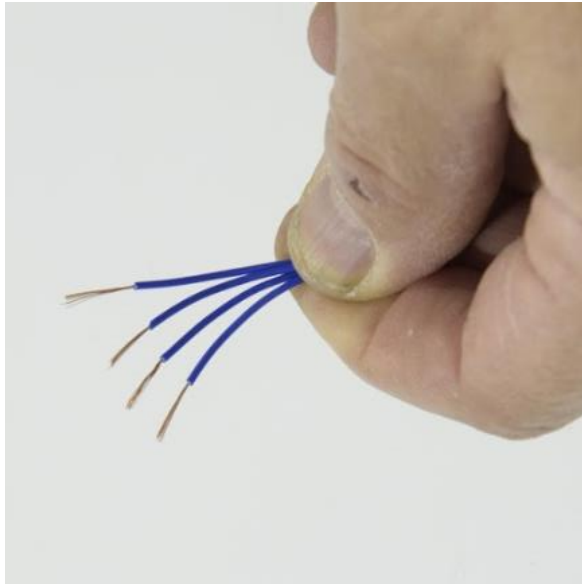

Step 5

With the locking lever open insert the bundled blue wires and close the locking lever as shown.

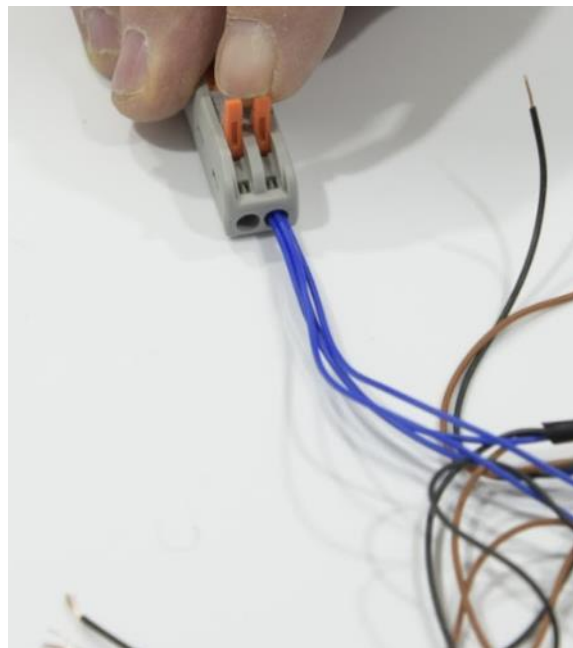

Locking lever open

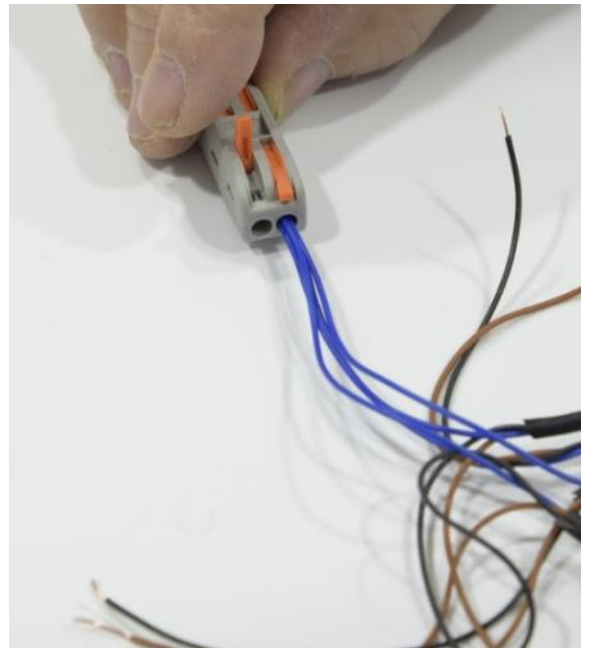

Locking lever closed

Step 6

Repeat the aligning, trimming and twisting all four of the brown wires, then insert into the connector as shown.

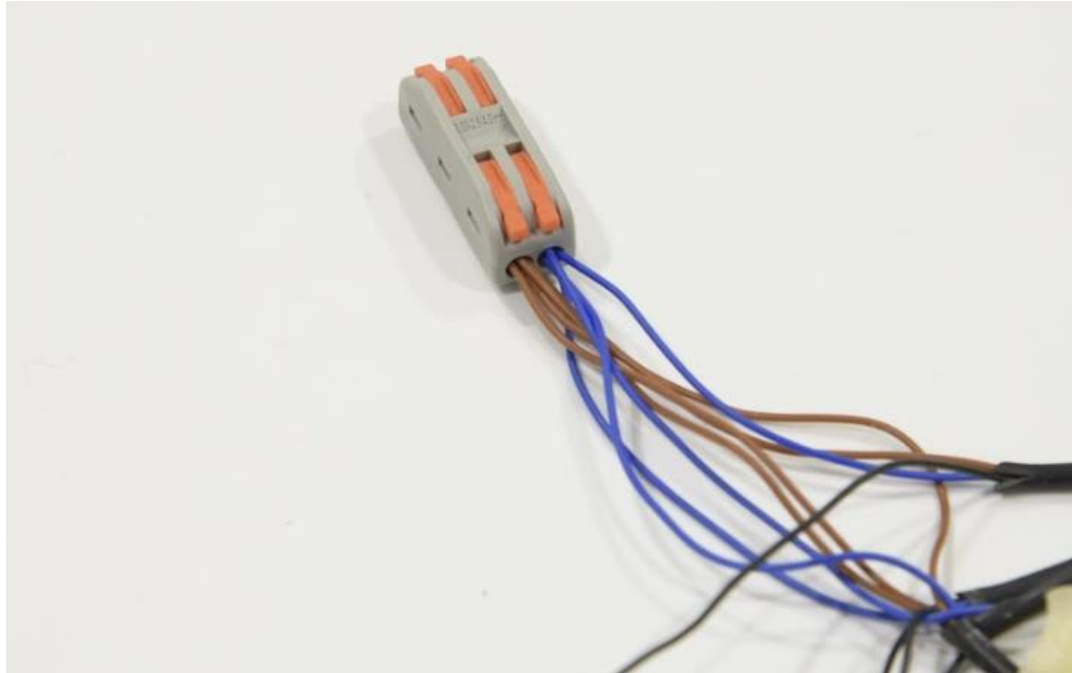

Step 7

Open the locking levers and insert the #22 brown and blue 80 mm wires in the opposite side of the connector and lock them into place by closing the lever as shown.

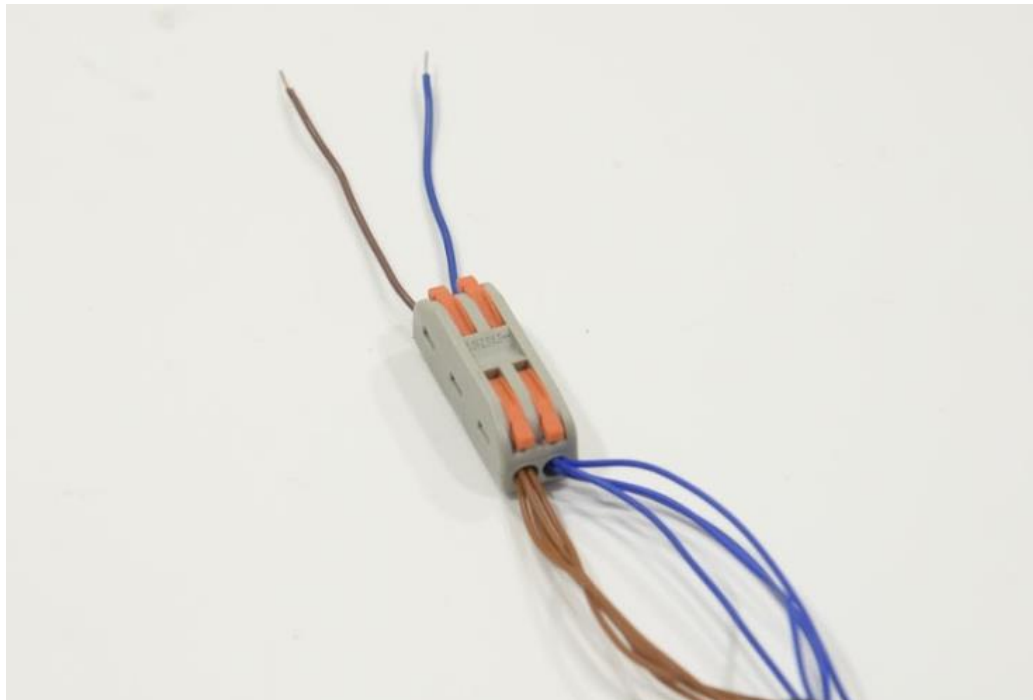

Step 8

Align, twist, and trim the X2 and Z black wires to 3/16 inches of exposed length as shown.

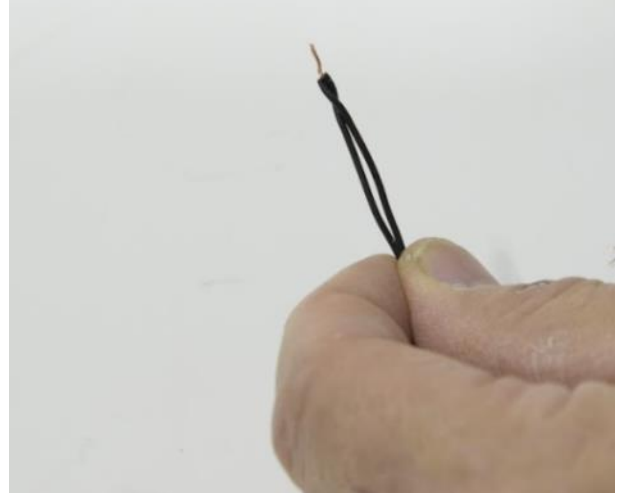

Step 9

Attach the twisted pair (X2/Z) to the D12 pin. Tighten securely in place and test by tugging on the wire.

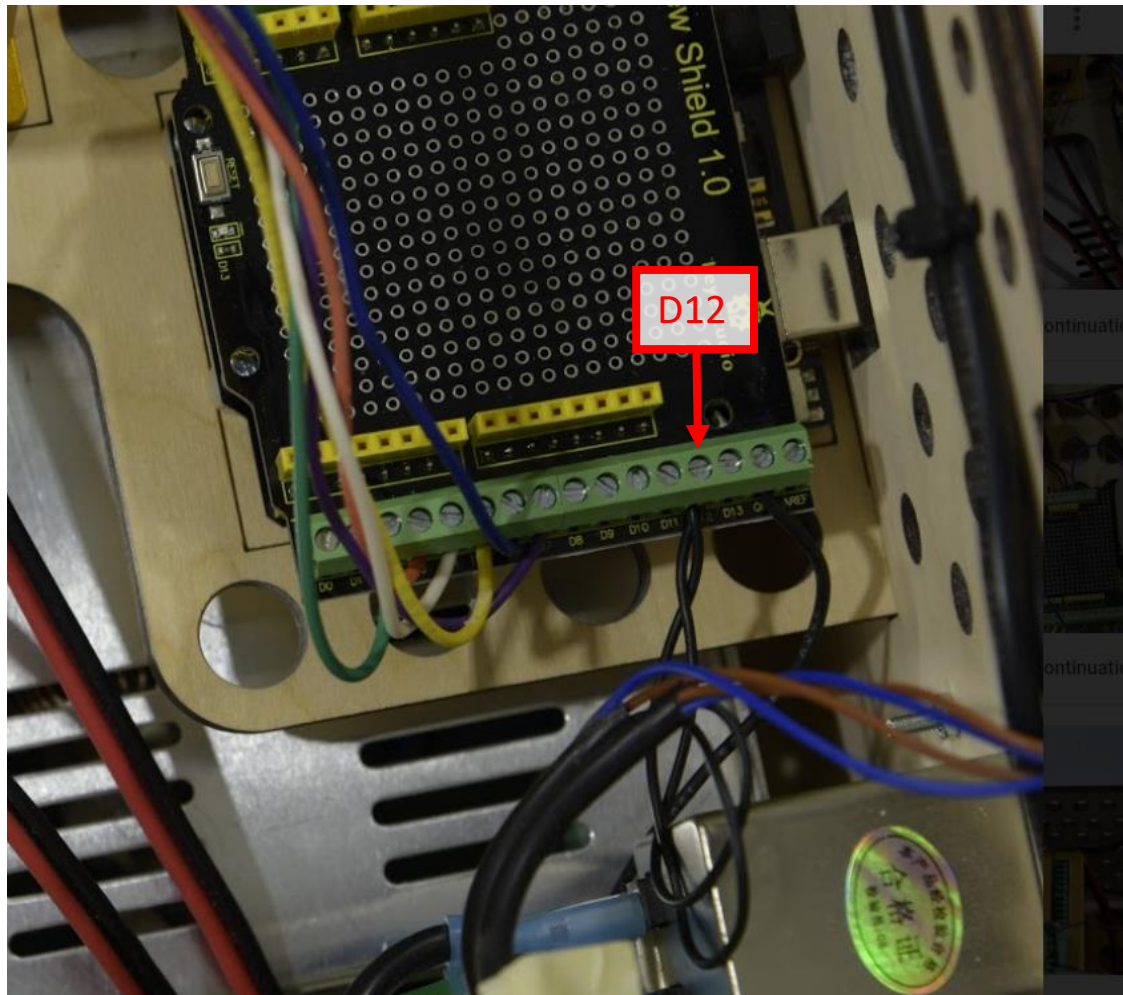

Step 10 Attach the Y Black Home wire to the D10 pin. Tighten securely in place and test by tugging on the wire.

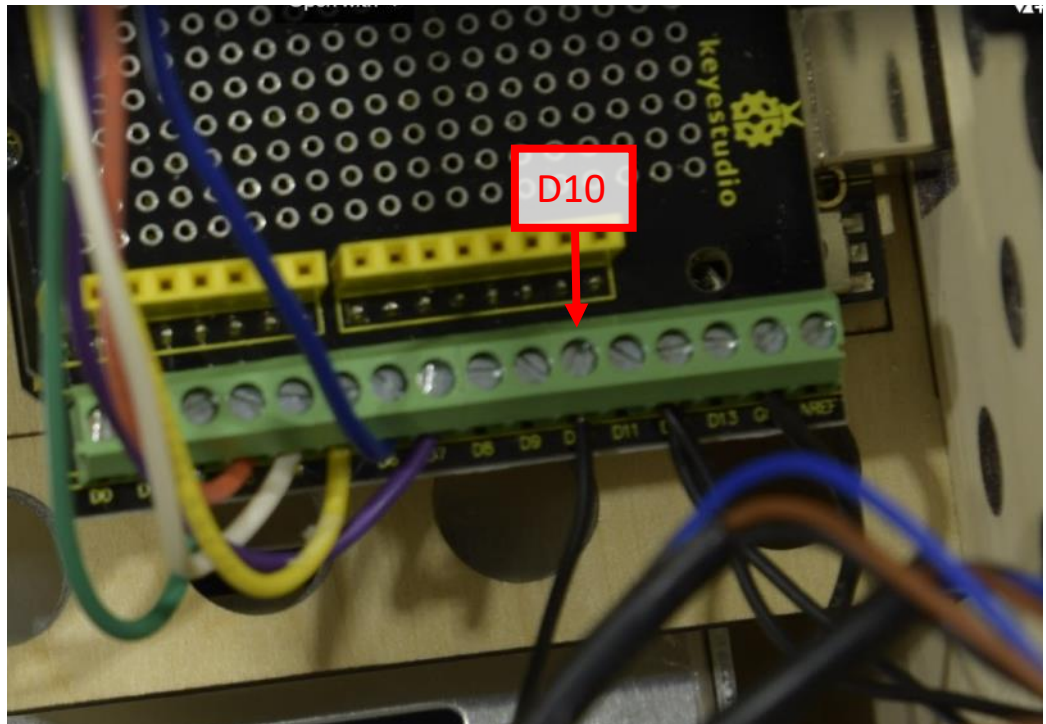

Step 11 Attach the X1 Black Home wire to the D9 pin. Tighten securely in place and test by tugging on the wire.

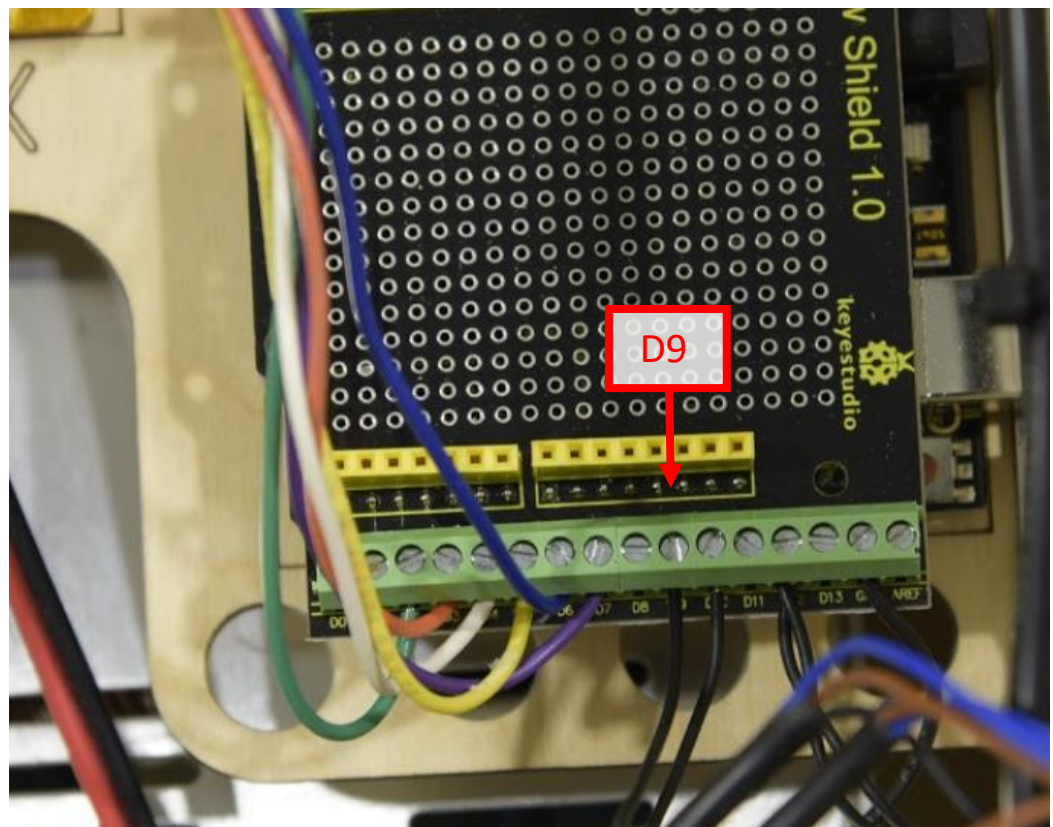

Step 12 Attach the blue ground wire to the Gnd pin. Tighten securely in place and test by tugging on the wire.

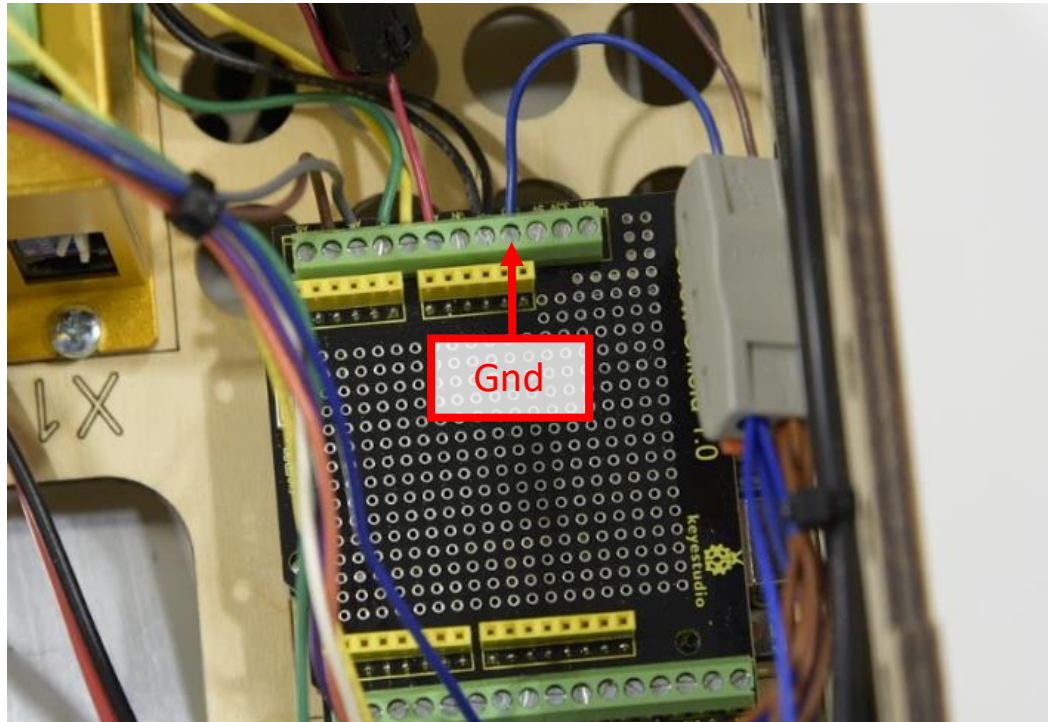

Step 13 Attach the brown power wire to the 5VDC pin. Tighten securely in place and test by tugging on the wire.

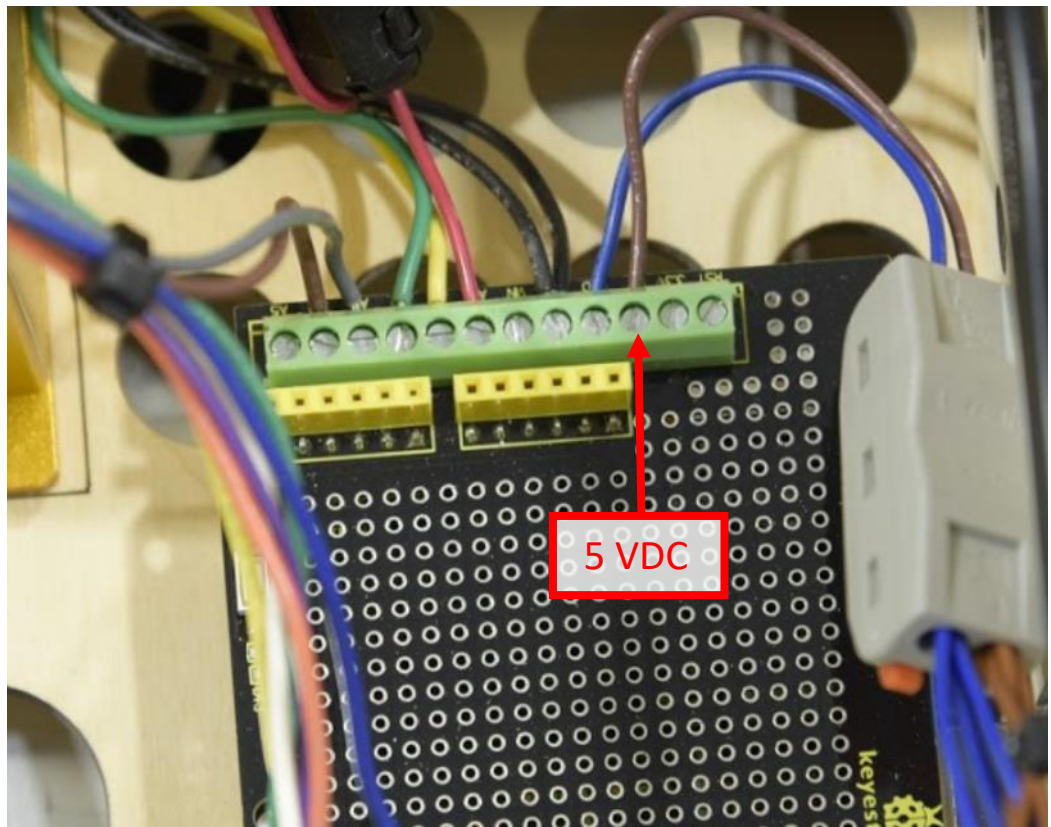

Connecting the Servo Motors

Step 1 Route the Z Servo Motor/Encoder Cables as shown.

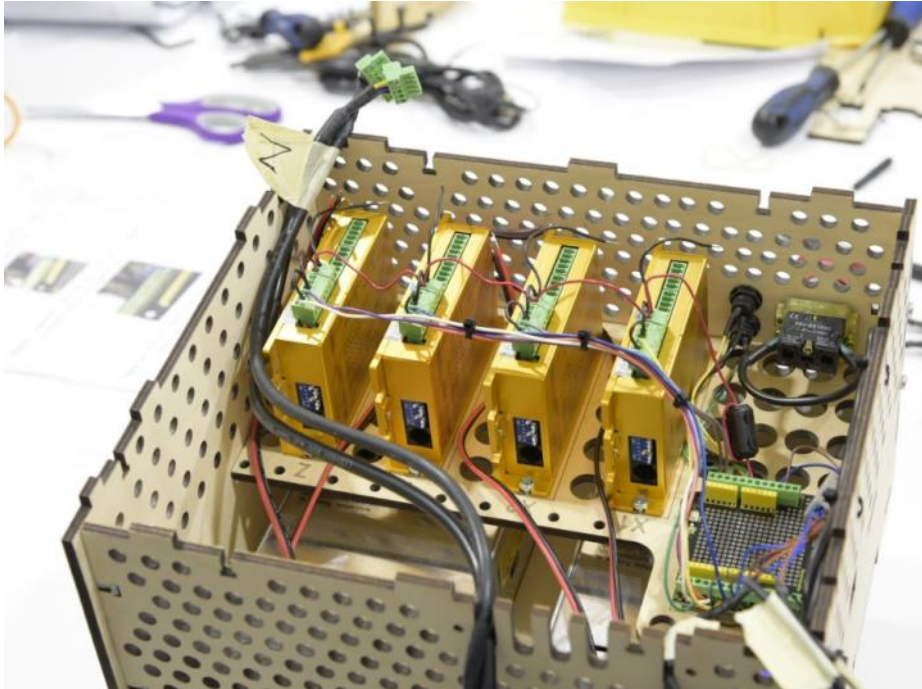

Step 2 Position Servo Motor Cable Connectors as shown.

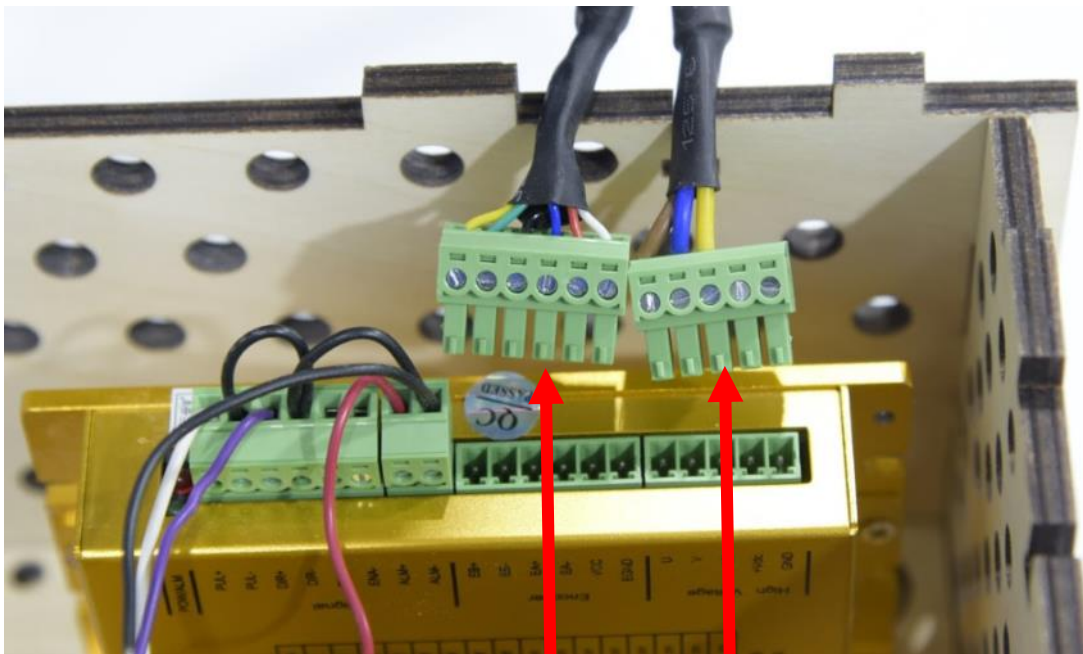

6-Pin Encoder Connector

5-Pin Motor Connector

Step 3

Connect the Z Servo Motor and Encoder Cables as shown.

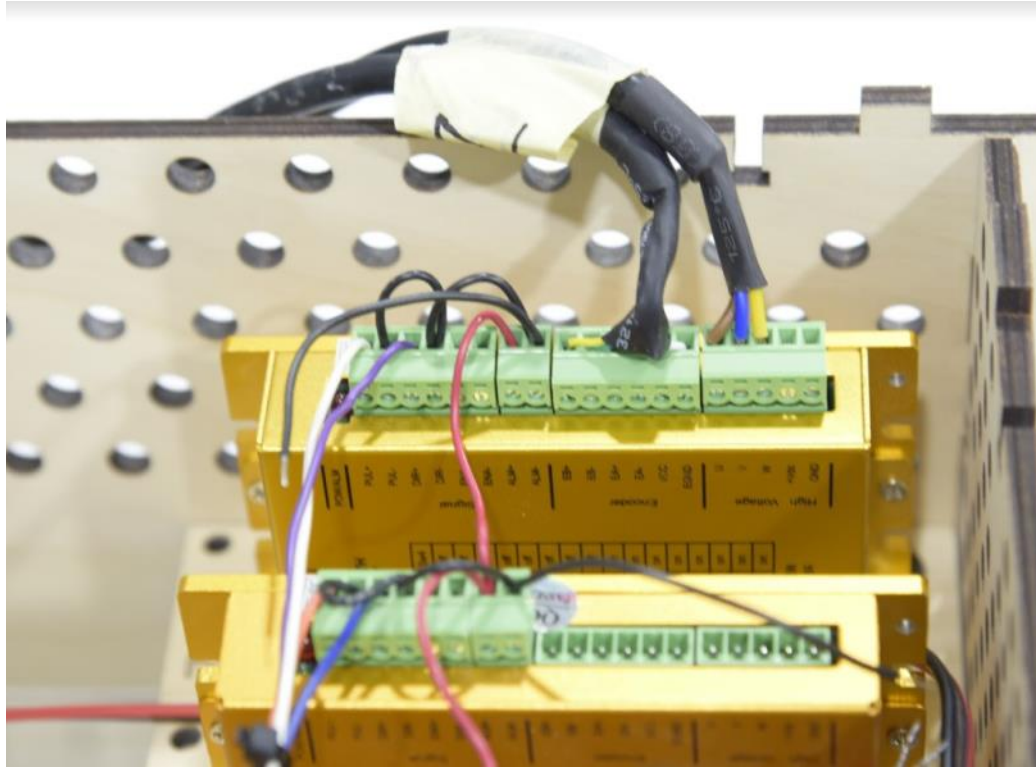

Step 4

Connect the red power supply wire to the +Vdc as shown.

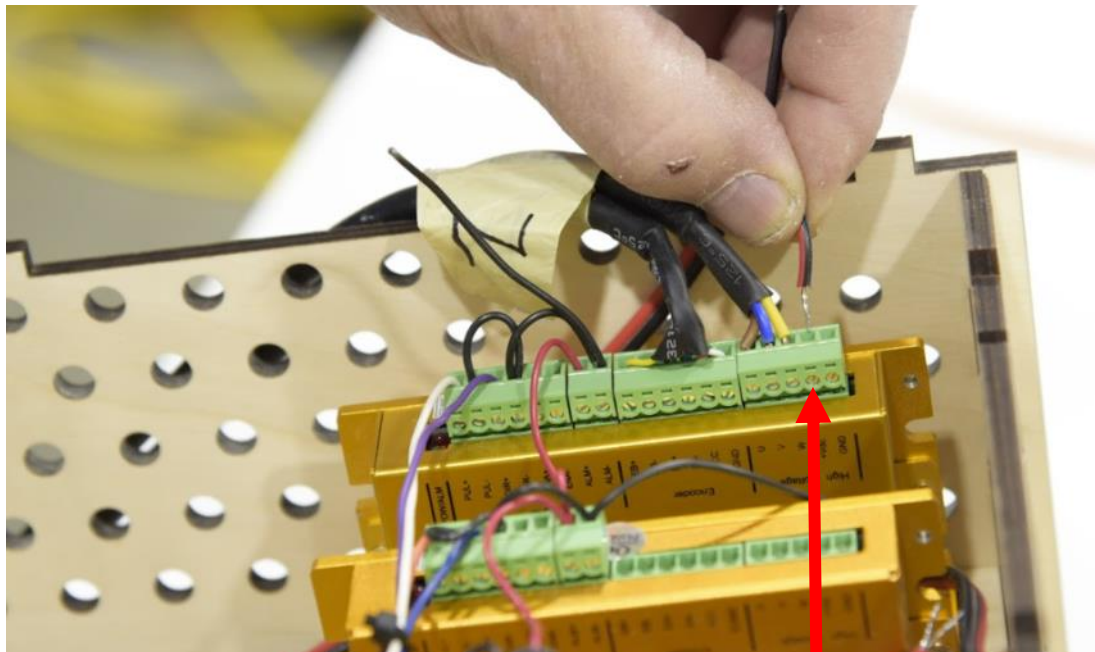

+Vdc

Step 5

Position both the power supply ground and jumper ground to the GND of the Connector as shown.

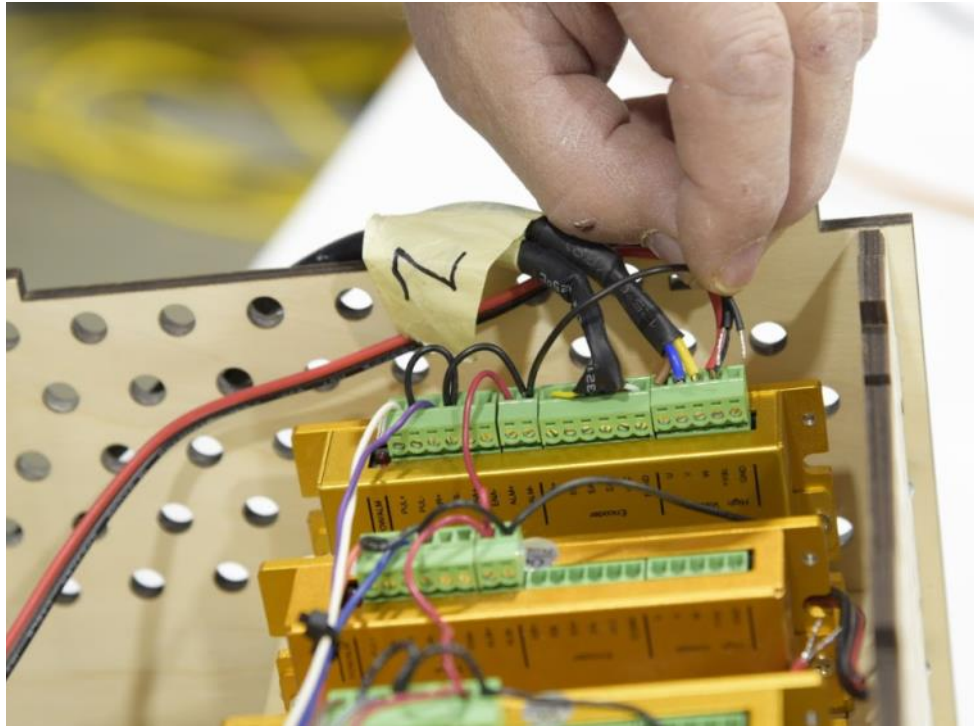

Step 6

Connect both the power supply ground and jumper ground to the GND of the Connector as shown.

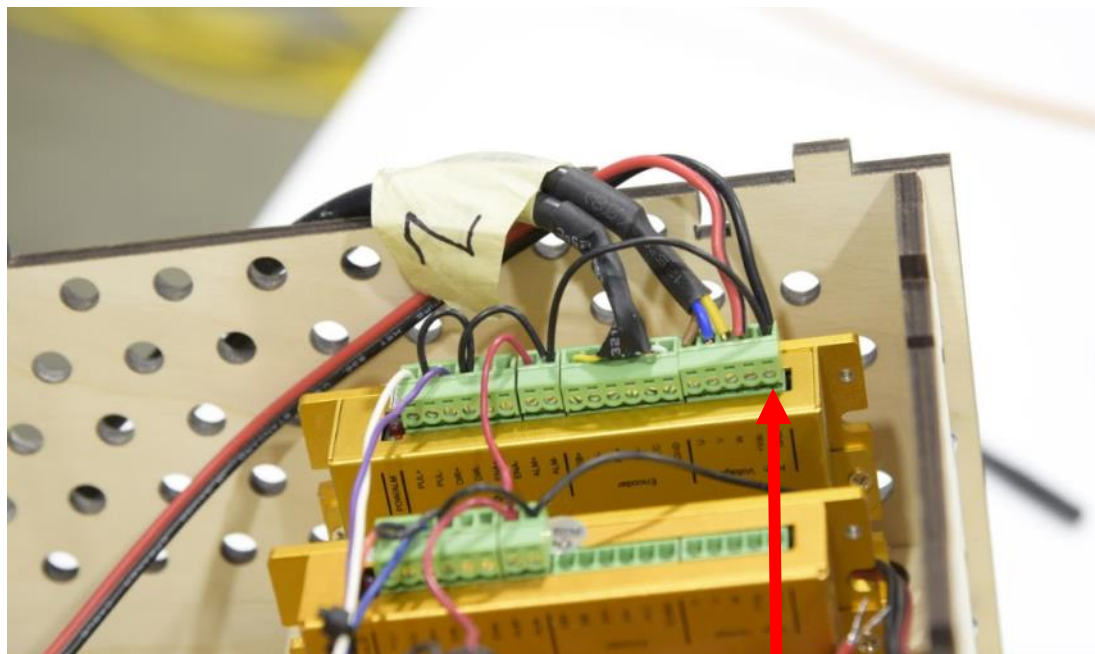

Two black wires connected to GND

Step 7

Zip tie the Z Servo Motor and Power Cables as shown.

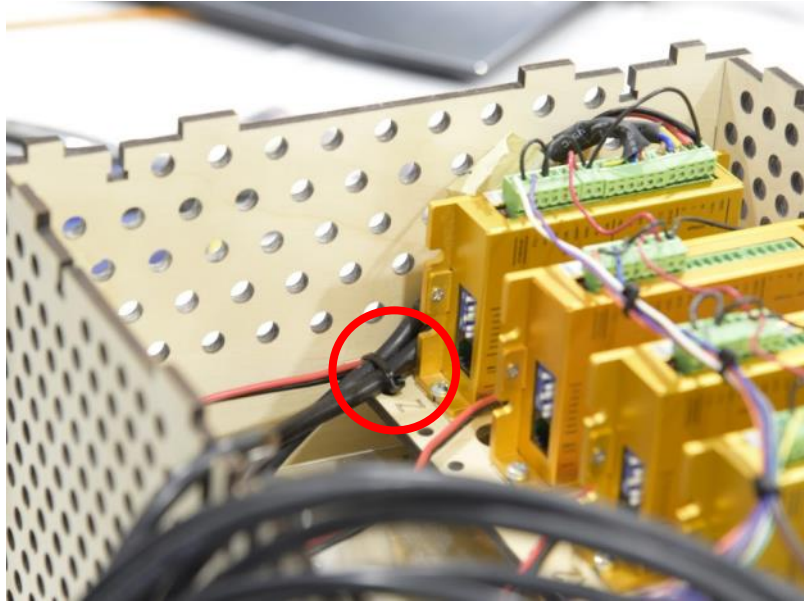

Step 8

Repeat the connecting process for the remaining three Servo Drivers as shown. (X1,X2 and Y)



Step 9

Place the C3 Wire Clamp into position and secure with 2 M4 x 16 Machine Screws and Nuts as shown.



Inside View

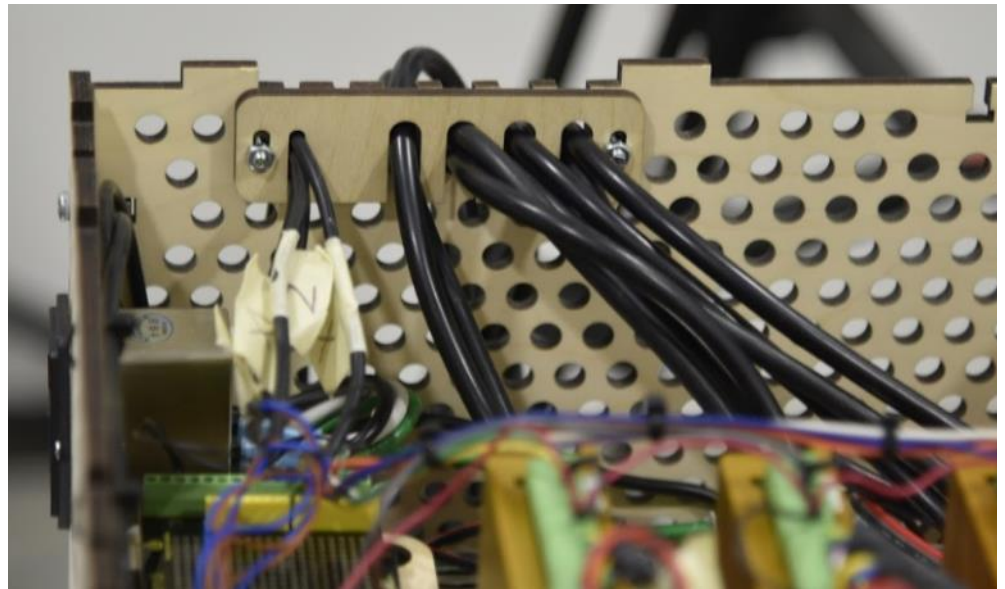

Outside View

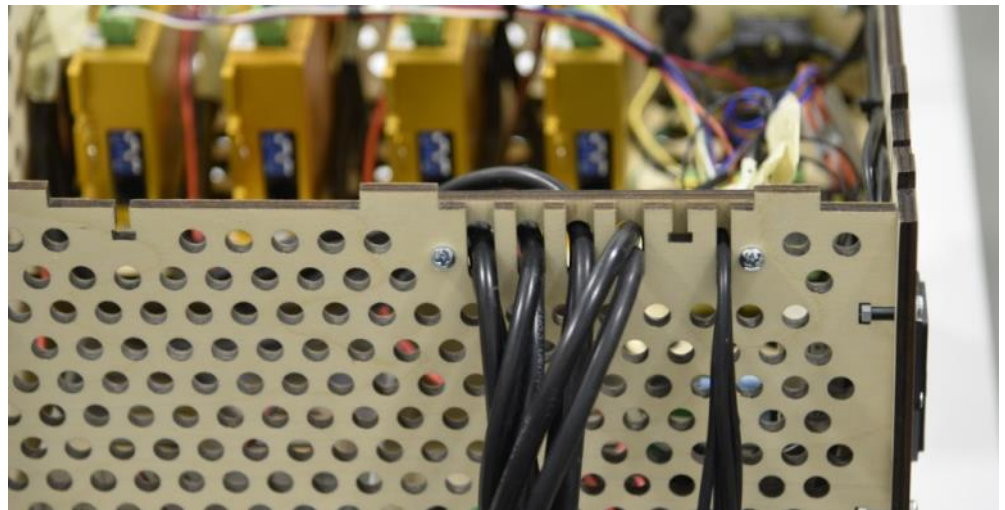

Final Controller Assembly

Step 1

Place C8 Top Plate into position. You will need to secure with eight M4 x 16 Machine Screws and Nuts once you verify that the CNC functions correctly. This can be done later.



Step 2

Insert the Power Cord



Front View



Back View

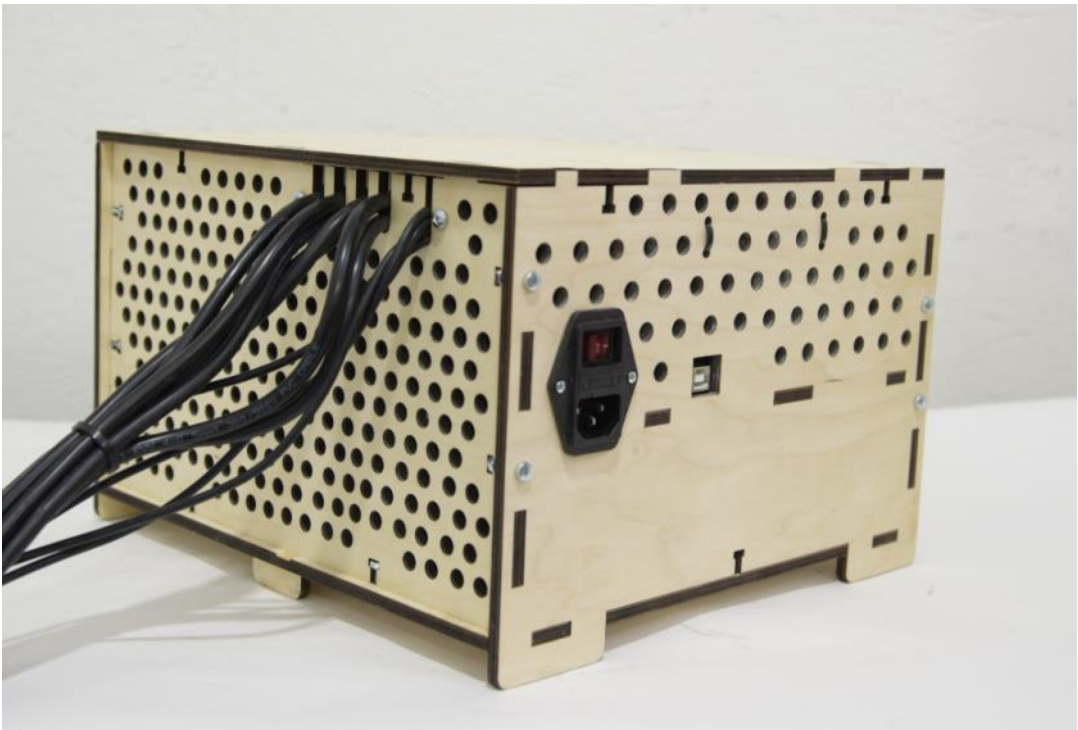

Attaching the Home Switch Magnets

Step 1

Plug in the USB to the Controller and to the computer.

NOTE: Connect the USB to your computer to power up the Home Switches. Once connected you will be able to determine the polarity, orientation, and placement of the Home Switch magnets. Software is not required to perform this step.

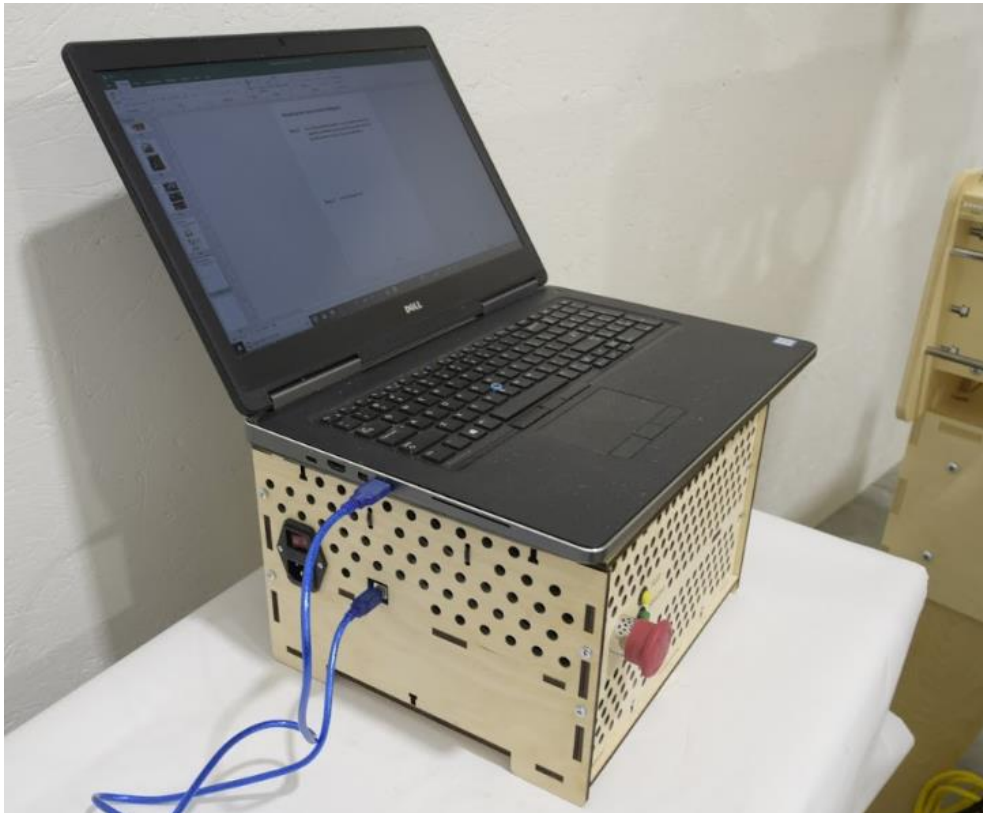

Attaching the Home Switch Magnets

Step 2

Position each side of the magnet close to the Home Switch until the LED illuminates. Draw an X on the side of the magnet that triggers the LED.

Repeat this process for the remaining three magnets.

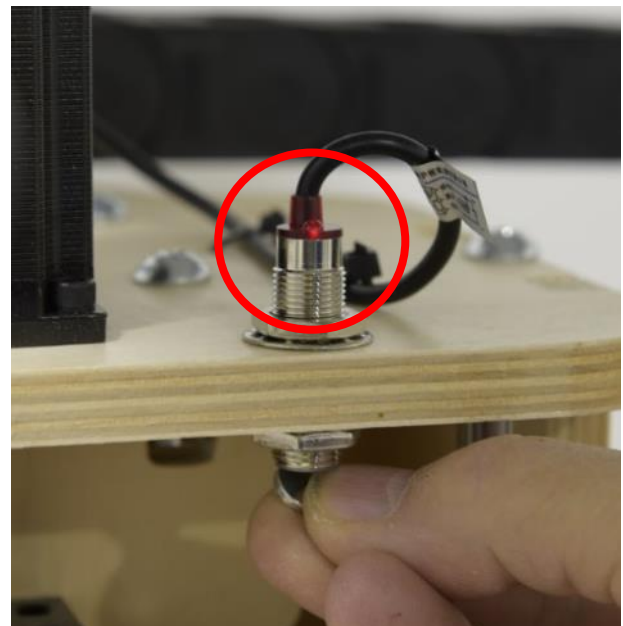

Step 3

Attach all 4 magnets in position using the double sided tape.

Note: The position of the X1, X2 and Y placement is designated by a small drilled hole.

The Z Magnet must be placed directly under the Home Switch as shown.

