

BobsCNC
Unleash Your Creativity

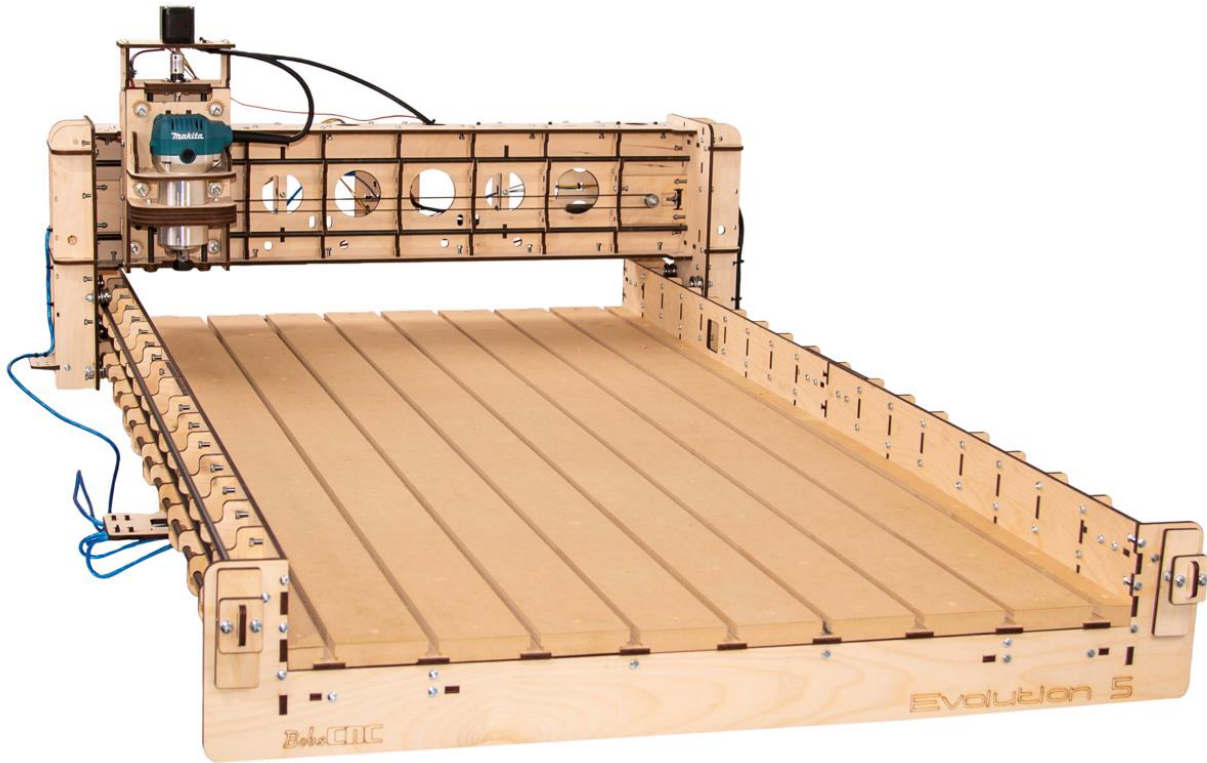

Evolution 5

Assembly Manual

Rev. 1.13

The Evolution Series CNC Router. Welcome to the Family.

We're excited that you purchased the Evolution 5 CNC Router Kit from BobsCNC, and we know you're just as excited to put it together.

This manual gives you step by step instructions to ensure your success in assembling the Evolution 5 CNC Router and provides all the information you need to get your machine up and running.

Before beginning the assembly, take the time you need to completely review the manual. It's good to be familiar with the entire assembly process before diving in. Be sure to check out the recommended tools you'll need for the assembly.

Welcome to the BobsCNC family. It's time to... Unleash Your Creativity!

Table of Contents

Information/Warning Boxes.....	5
Safety Precautions and Warnings	6
Getting Started.....	7
Required Tools:.....	7
To Operate the EVOLUTION 5 CNC Router, you need will need:	7
Recommended for the electronic setup include:	7
Assembly Recommendations:	8
Z Spindle Mount Assembly:	9
Required Wood Components	9
Required Hardware	11
Illustrated Step by Step Instructions	12
Y Carriage Assembly	24
Required Wood Components	24
Required Hardware	25
Illustrated Step by Step Instructions	33
Gantry Assembly.....	41
Required Wood Components	41
Required Hardware	42
Illustrated Step by Step Instructions	45
Front View (Right Hand Side) Completed	59
X Frame Instructions	84
Required Wood Components	84
Required Hardware	85
Illustrated Step by Step Instructions	86
Final Assembly.....	104

Wood Components (Included with Kit).....	104
Required Hardware	104
Illustrated Step by Step Instructions	106
T-Slot Spoilboard	138
Wood Components	138
Required Hardware	138
Completed Views	145
Tramming	150
Clamping System	152
Wood Components (Included with Kit).....	152
Required Hardware	152
Congratulations! You Just Completed the Assembly of Your Evolution 5.	153
Updating Firmware.....	153
Evolution 5 Firmware Value Change	153
Appendix (\$130=1283)	154
Evolution 5 Firmware Values	154
Evolution Washer Dimensions.....	155

EVOLUTION 5 Specifications

Laser cut 6mm Baltic Birch Frame components.

Fully Engineered Frame with rigid Box and Beam Gantry.

Fully supported 5/16-inch stress proof steel Rails with SG20U Bearings.

GT2 Belt Drive on X and Y axis.

2 mm pitch, 4 start Acme Threaded Rod on Z axis.

Home Switches with Self Squaring Gantry.

¾" MDF T-Slot Spoilboard

Accuracy .002 to .004 inch.

The assembled footprint:

Length: 60.5" (1537 mm)

Width: 39" (994 mm)

Height: 20.9" (530 mm)

Assembled Weight:

48 lbs.

Cutting Area:





X: 50.5" (1283 mm)

Y: 24" (610 mm)

Z: 3.3" (85 mm)

Safety is the First Priority. Always wear proper protective equipment and use "safety sense" when assembling and operating your Evolution 5 CNC Router.

Information/Warning Boxes

	CAUTION Indicates a possible risk of injury that can result from failure to follow this instruction
	WARNING Indicates the possible damage to the machine, its components, the work piece, or injury that can result from failure to follow this warning.
	DANGER Indicates a serious risk of bodily harm, injury and death. This is a serious warning and should not be ignored. Any work must be carried out with extreme caution.
	TIPS Contains helpful information, shortcuts, and hints to simplify assembly and make machine operation easier and safer.

Safety Precautions and Warnings

Evolution Series CNC Routers have a 110 v. Power Supply and use bits that spin at 30,000 rpm with cutting edges that are sharp and hazardous. The operator must understand the potential hazards and is responsible to take appropriate safety precautions before operating the Router.

- Only use extension cords rated for 20 amps plugged into a dedicated outlet.
- Inspect the machine before every use for maintenance issues: loose fasteners, belts, etc.
- Do not operate the machine with dull or damaged router bits.
- Always unplug machine after each use and when cleaning the router or changing router bits.
- Remove rings, bracelets, watches, necklaces before using the machine.
- Wear snug fitting clothing and/or roll up long sleeves to prevent snagging.
- Use appropriate personal protective equipment (PPE) when operating machine including safety glasses and hearing protection.
- Keep hands, hair and clothing away from the moving parts of the machine.
- Do not operate the machine when under the influence of alcohol or prescription medications.
- Make certain the workpiece is clamped securely in place before starting the machine.
- Never leave the machine running unattended.
- Children must be supervised by adults when operating the machine.
- Do not operate the machine in the presence of flammable materials.
- Keep floors clean, dry, and free of debris to eliminate slip and/or trip hazards.
- Have a suitably rated fire extinguisher on hand when the machine is in operation.

Getting Started

Required Tools:

A pair of long nose pliers.

Diagonal Cutters or sharp knife to trim nylon ties.

Calipers or measuring tape to measure part placement.

Small standard screwdriver to connect electronics.

#2 Phillips screwdriver to mount home switches and stepper motors.

#3 Phillips screwdriver to build the main components.

220 grit sandpaper to remove laser marks on wood pieces (if desired).

LOCTITE 242™ thread lock (fingernail polish can be used as a substitute).

Set of Metric Sockets and SAE Wrenches.

Set of Metric and SAE Allen Wrenches.

To Operate the EVOLUTION 5 CNC Router, you need will need:

Computer with control software for GRBL.

Materials for Projects.

1/4" Shaft Router bits.

Recommended for the electronic setup include:

Multimeter to correctly connect the Power Supply and to set the current for the Stepper Motors (a great tool for general electronic trouble shooting).

Assembly Recommendations:

Use a large, flat, clean work surface for assembling your EVOLUTION 5.

All Screws (unless noted) should be installed snug, then rotated 1-2 ½ turns.

Apply LOCTITE to all M4 X 16 mm Machine Screws that are used to secure plywood pieces except for the 4 screws that clamp the router in step 10 of the final assembly.

Light sanding may be required to remove any marks made by the laser.

Painting, or applying stain with a clear coat will provide extra protection to the wood components

Try using strips of 1-inch blue painters' tape behind the T-Slots to help hold the Nuts in place during assembly.

Clean the Rails with acetone to remove rust preventative and apply a light coat of PTFE lubricant.

Lock Nuts are never used to secure components that have T-Slots. They are only used to mount components where the Nut is not held in a T-Slot.

When a component has a T-Slot the nut is always placed in the slot as shown. The Machine Screw is threaded through the adjoining component into to the nut and tightened as noted above.

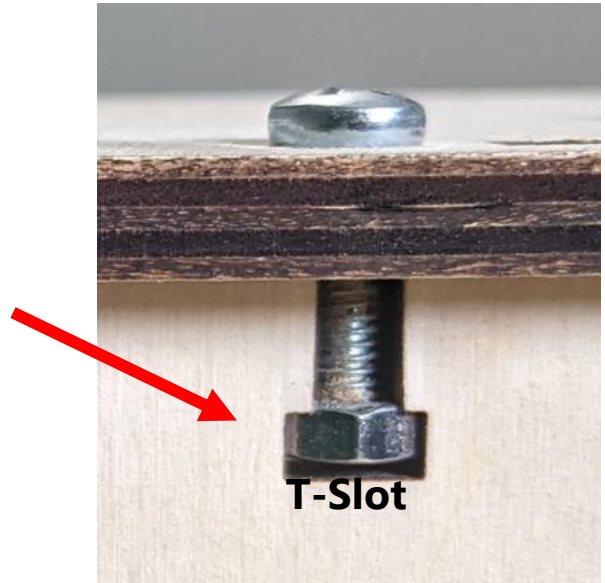

	<p>CAUTION This kit contains numerous small components that pose a choking risk for small children and pets. Keep kit pieces in a secure location out of the reach of small children and pets.</p>
--	---

Z Spindle Mount Assembly:

Required Wood Components

Part #	Description	Qty	Photo
Z1	Z Frame Mount Support	2	

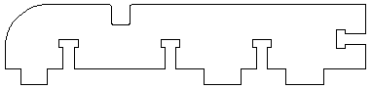
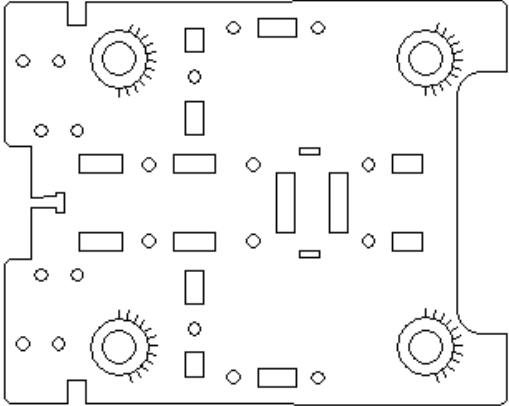
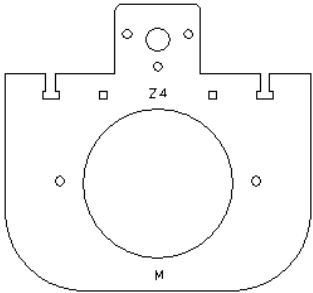
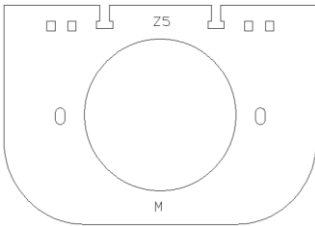
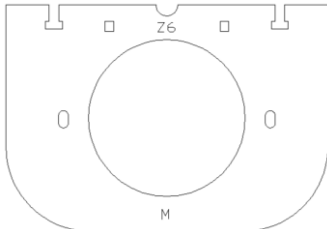
Z2	Z Frame Support	2	
Z3	Z Frame	1	
Z4	Z Spindle Bottom Mount	1	
Z5	Z Spindle Interlock Bottom	1	
Z6	Z Spindle Interlock Top	1	

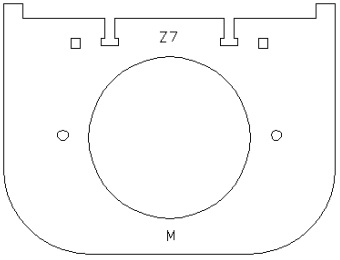
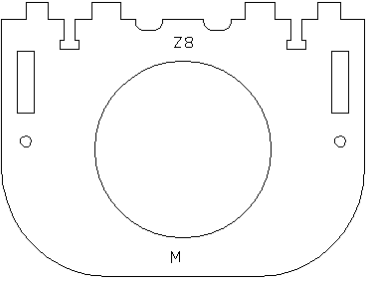
Z7	Z Spindle Top Mount	1	
Z8	Z Spindle Support	1	

Required Hardware

Part #	Description	Qty	Photo
ZD2	Acme Block Nut	1	
H31	8" Zip Tie	1	
H39	M6 x 30 Machine Screws	4	
H18	M6 Locknuts	4	
H40	Eccentric Adjustment Spacer	4	
H41	Eccentric Washer	4	
H42	Bearing Fender Washer	4	

H44	SG20U Bearings	4	
H38	M4 x 30 Machine Screws	2	
H14	M4 x 16 Screws	25	
H15	M4 Nuts	25	
H47	M4 Lock Nuts	2	

Illustrated Step by Step Instructions

The Z Carriage Assembly holds the Router securely in a carriage that travels up and down the Z-axis on a set of Rails. These first steps will show you how to build the Spindle (Router) Mount.

NOTE: The Z Frame has alignment marks that are used to snug the SG20U Bearings to the Rails and later to tram the Router. When assembling the Z Carriage, it is important that the adjustment marks face toward the Spindle Mount as shown in the following photos.

Step 1 Attach the Z Spindle Bottom Mount (Z4) to the Z Frame (Z3) with three M4 x 16 Machine Screws and Nuts as shown.

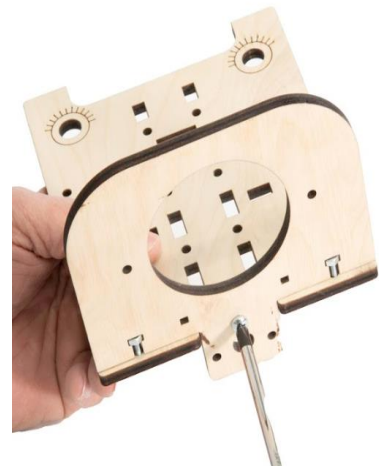

Step 2 Loosely attach Spindle Interlock Bottom (Z5) to the Z Frame Assembly with two M4 x 16 Machine Screws and Nuts as shown. Do not tighten the machine screws and nuts or use LOCKTITE. They will be tightened in a later step after the Router has been mounted.



Step 3

Loosely attach the Spindle Interlock Top (Z6) to the Z Frame Assembly with two M4 x 16 Machine Screws and Nuts as shown. Do not tighten the Machine Screws and Nuts or use LOCKTITE. They will be tightened in a later step after the Router has been mounted.



Step 4

Attach the Spindle Top Mount(Z7) to the Z Frame Assembly with two M4 x 16 Machine Screws and Nuts as shown. Do not tighten the Machine Screws and Nuts at this stage. They will be

tightened in a later step after the Router has been mounted. The Interlock Bottom and Top must be able to move slightly from front to back, this allowance will make installing the Router easier. You only need to make sure that the Machine Screws and Nuts are engaged to keep the Screws from falling out.

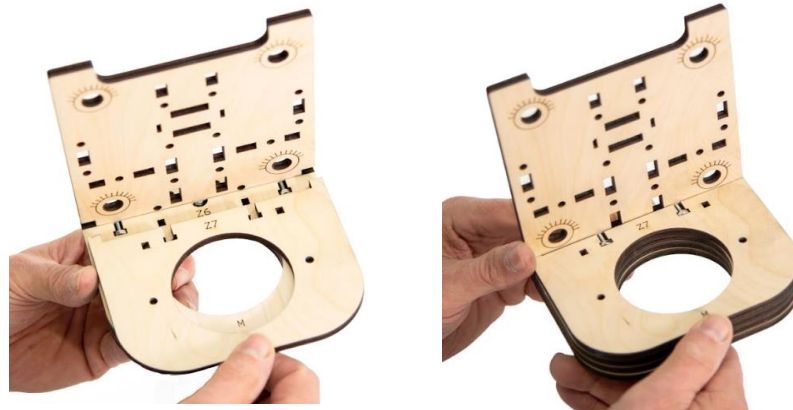

Step 5 Loosely secure the Z Spindle Bottom Mounts together with two M4 x 30 Machine Screws and Locknuts as shown. Do not fully tighten the Nuts.

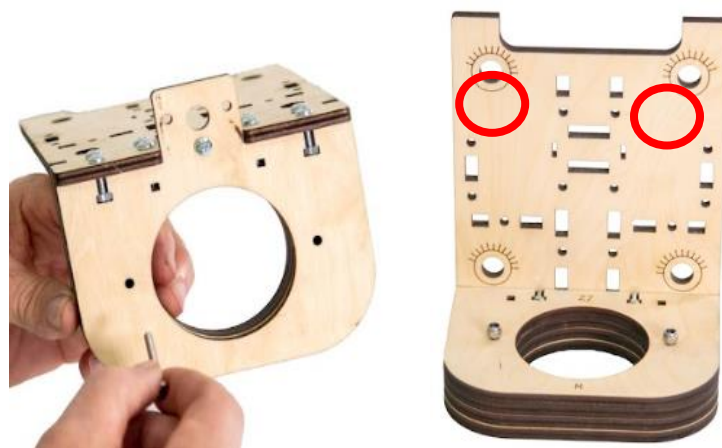

Step 6

Z
(Z2)

Attach the
Frame
Support
to the
Spindle

Assembly with four M4 x 16 Machine Screws and Nuts as shown.



Step 7 Fit the tabs on the Acme Block Nut (ZD2) into the slots on the back side of the Frame Assembly as shown. The ACME Block Nut tabs are designed to be a snug fit. If the ACME Block NUT fit is too tight, use sandpaper to sand the outer faces of the rectangular slots as shown with the red arrows below until the block fits snugly onto the slots.

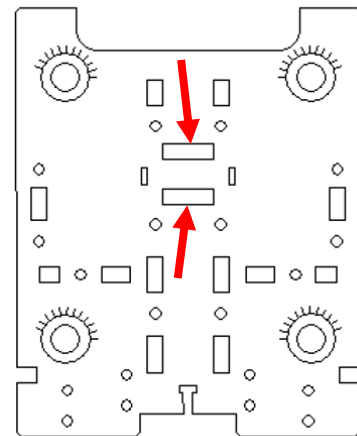

Step

8

Attach the second Z Frame Support (Z2) to the Spindle Top Plate Assembly with four M4 x 16 Machine Screws and Nuts

as shown. Be careful to keep the Acme Block Nut securely in place.



Step 9 Wrap an 8" Zip Tie around the Frame Supports as shown. Make sure the Zip Tie Lock is positioned on the Router side of the Assembly.





Test fit the Router in the Support Assembly as shown. This will help align the interlocking center pieces prior to final assembly and tightening. Remove the Router after dry fitting is completed.

Video Link: <https://www.youtube.com/watch?v=SkQ55V6ymEs&t=69s>



Step 10 Attach four SG20U Bearing Assemblies to the Z Frame. Loosely tighten the nuts. These will be adjusted and tightened at a later step.

	<p>When putting the Bearing Assembly together, make sure the hub on the Bearing faces the wood. IMPORTANT: The Screw must be oriented so that the Nut is visible when looking at the back of the carriage (see photo below).</p>
---	---

NOTE: Bearing Assembly Order with Eccentric Adjustment Spacer: M6 X 30 Machine Screw Head, Bearing (with hub facing toward the Bearing Washer), Bearing Washer, Eccentric Washer, Eccentric Adjustment Spacer, M6 Locknut.



Hub





Prior to putting the Bearing Assembly together, mark the point of the inboard edge of the Eccentric Adjustment Spacer using a permanent marker as shown below. This mark will help orient the Nut for tramming.



**Mark this
inboard point**

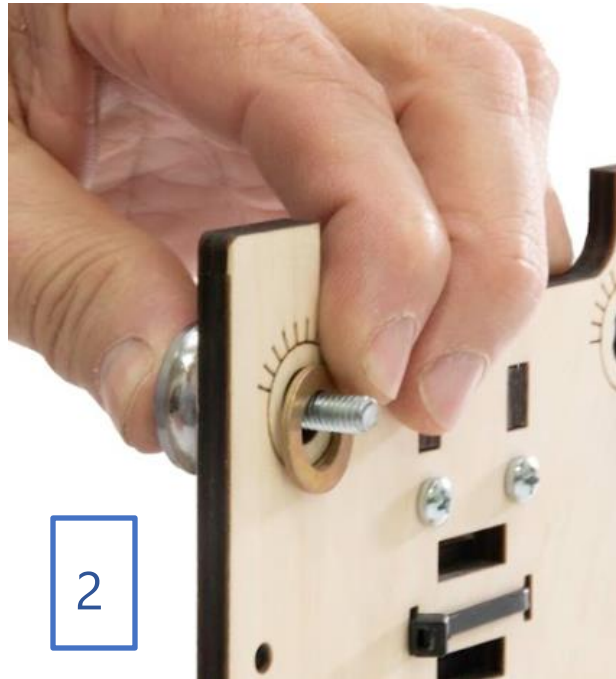

Step 11 Attach the two (Z1) Z Frame Mount Supports to the (Z8) Z Spindle Support and secure with two M4 x 16 Machine Screws and Nuts.



Step 12 Attach the Spindle Support Assembly to the Z-Frame Assembly with six M4 x 16 Machine Screws and Nuts as shown.







The finished Z Assembly should look like this:

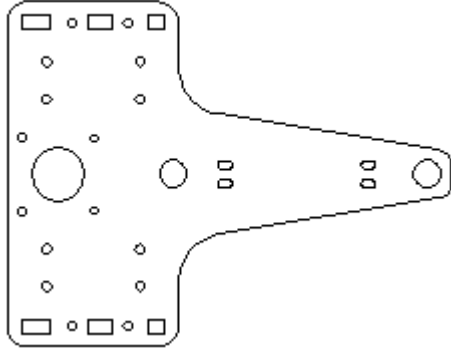
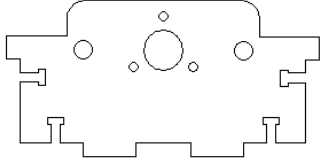

Y Carriage Assembly

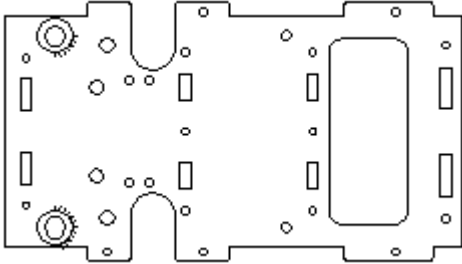
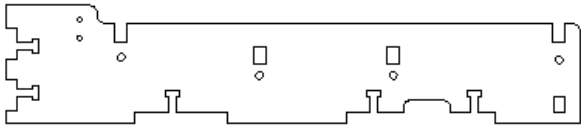
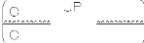
Required Wood Components

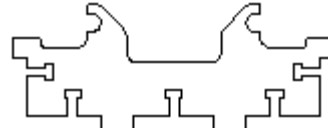

Part #	Description	Qty	Photo
Y1	Z Stepper Motor Mount	1	
Y2	Rail Top Support	1	
Y3	Bearing Retainer Plate	1	
Y4	Y Carriage Frame	1	
Y5	Y Carriage Side Support	2	
Y6	Belt Retainer	1	

Y7	Z Rail Stop	1	
Y8	Carriage Bottom Support	1	
Y9	Rail Support	2	

Required Hardware

Part #	Description	Qty	Photo
H57	Bearing Retainer Washer	3	
CB11	Stepper Motor	1	
ZD5	Aluminum Helical Coupler	1	
H44	SG20U Bearing	4	
ZD1	ACME Rod	1	

H66	Small Shim Washer	2	
H39	M6 x 30 Machine Screw	4	
H18	M6 Locknut	4	
H40	Eccentric Adjustment Spacer	2	
H41	Eccentric Washer	2	
H42	Bearing Fender Washer	6	
H47	M4 Lock Nut	9	
H14	M4 x 16 Machine Screw	37	
H15	M4 Nut	28	
ZD3	626-2RS Bearing	1	
ZD4	6mm Split Locking Collar	1	
H54	Stress Proof Steel Z-Rail	2	
H27	M2.5 x 16 Machine Screw	2	

H43	M2.5 Lock Nut	2	
CB13	Home Switch	1	
H37	M3 x 10 Machine Screw	4	

Illustrated Step by Step Instructions

Step 1 Attach the Belt Retainer (Y6) to the back side of the Y Carriage Frame (Y4) and secure with four M4 x 16 Machine Screws and Lock Nuts as shown below. Make sure the 'UP' mark is visible and oriented toward the top of the Y Carriage Frame (NOTE: The Eccentric Bearing adjustment marks are on the opposite side of the Y Carriage Frame as shown).

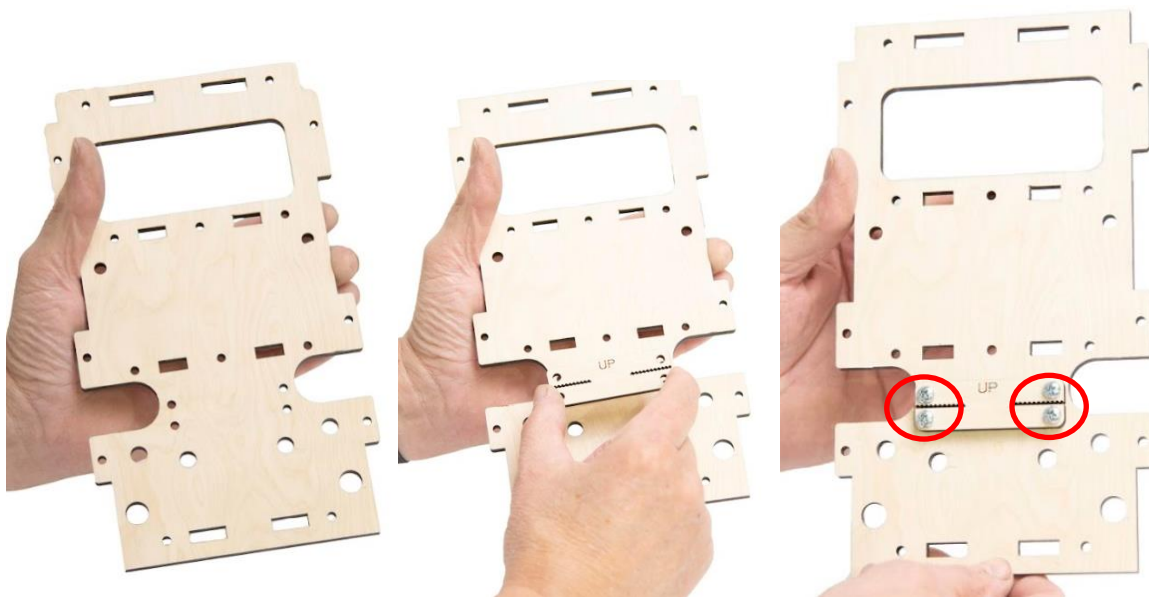

Step 2 Attach the SG20U Bearings

- 2a** Attach the two upper SG20U Bearings to the Y Carriage Assembly as shown.

NOTE: The assembly order for the Upper Bearing is; Machine Screw, SG20U Bearing (with hub facing toward the Bearing Washer), Bearing Washer, Plywood, Bearing Washer secured with a Lock Nut.



Upper Bearing Assembly

- 2b** Attach the two lower SG20U Bearings to the Y Carriage Assembly as shown.

NOTE: The assembly order for the Lower Bearing is; Machine Screw, SG20U Bearing (hub facing toward the Bearing Washer), Bearing Washer, Plywood, Eccentric Washer, Eccentric Adjustment Spacer, secured with a Lock Nut.

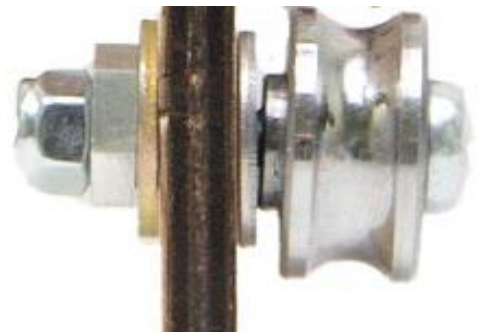

Lower Bearing Assembly with Eccentric Adjustment Spacer

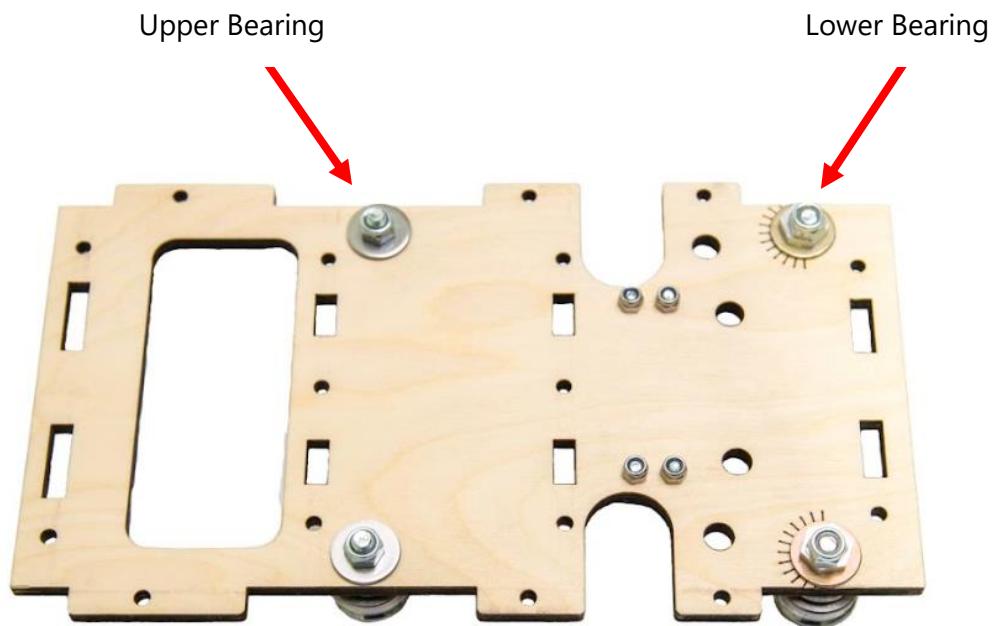

Step 3 Attach the Carriage Bottom Support (Y8) to the Y Frame Assembly with two M4 x 16 Machine Screws and Nuts as shown.

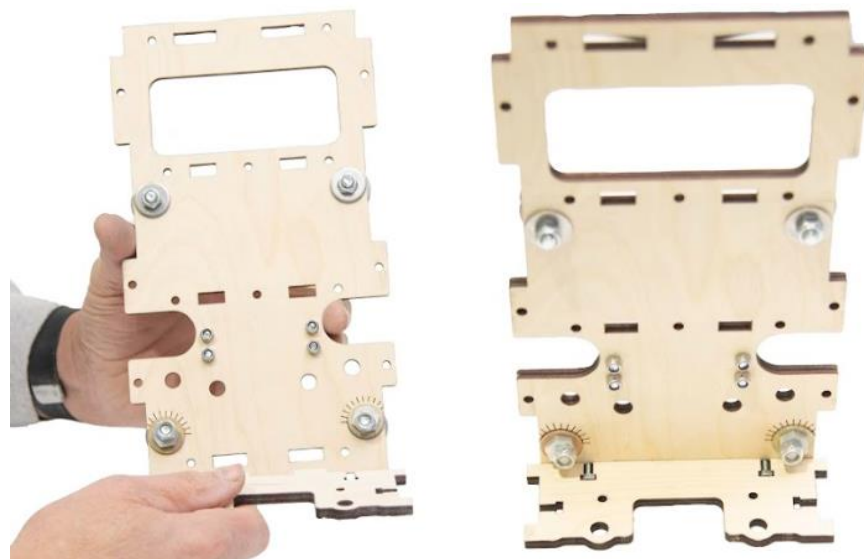

Step 4

Attach one Rail Support (Y9) to the Y Frame Assembly with three M4 x 16 Machine Screws and Nuts as shown.

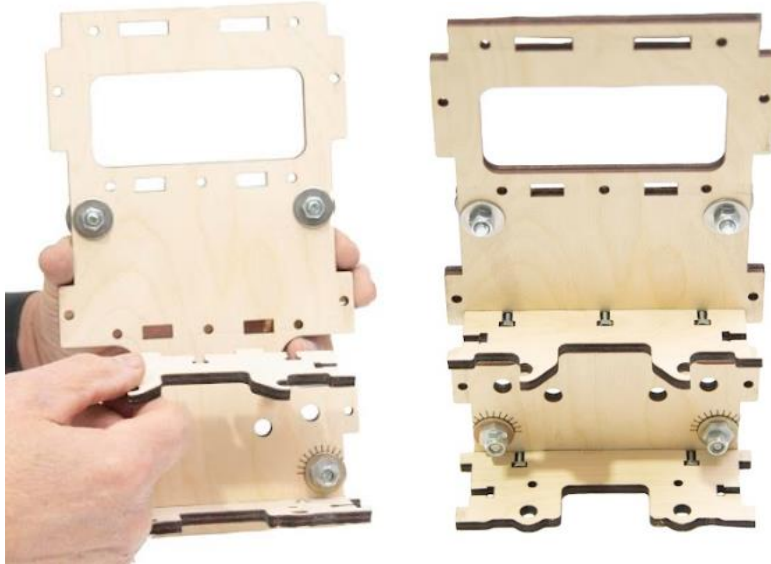

Step 5

Attach the second Rail Support (Y9) to the Y Frame Assembly with three M4 x 16 Machine Screws and Nuts as shown.



Step 6

Attach the Rail Top Support (Y2) to the Y Frame Assembly with two M4 x 16 Machine Screws and Nuts as shown.



Step 7

Attach the Z Rail Stop (Y7) to the Y Frame Assembly with two M4 x 16 Machine Screws and Lock Nuts as shown.



Step 8

Attach one Y Carriage Side Support (Y5) to the Y Frame Assembly with seven M4 x 16 Machine Screws and Nuts as shown.

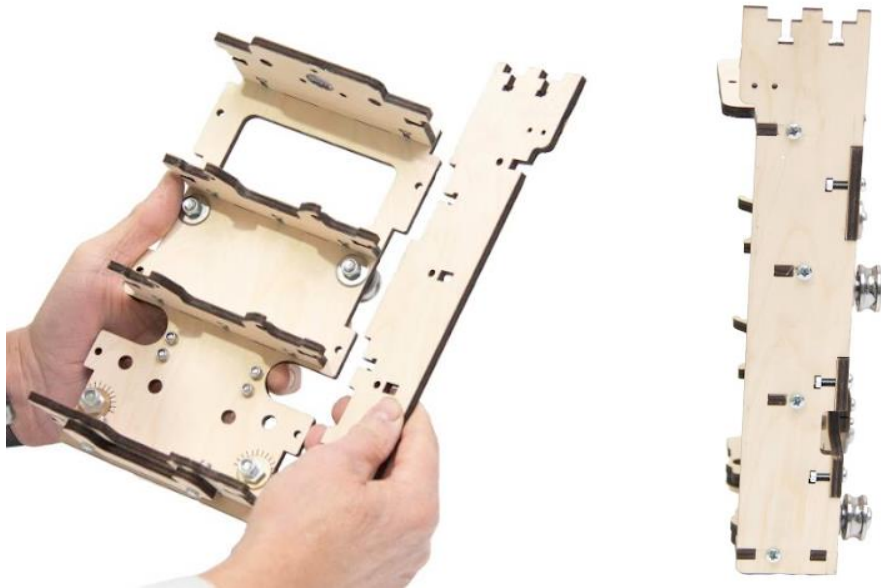

Step 9

Follow the same process to attach the second Y Carriage Side Support (Y5) to the Y Frame Assembly using seven M4 x 16 Machine Screws and Nuts as shown.



Y and Z Carriage Assembly

Illustrated Step by Step Instructions

	<p>WARNING Prior to installing the Lower Rails, adjust the Eccentric Spacers so that the lower Bearing Assemblies are at their outboard position.</p>
---	--

Step 1 Lay the Y Carriage Assembly with the Bearings facing down. Fit Z Carriage Assembly into Y Carriage Assembly as shown.

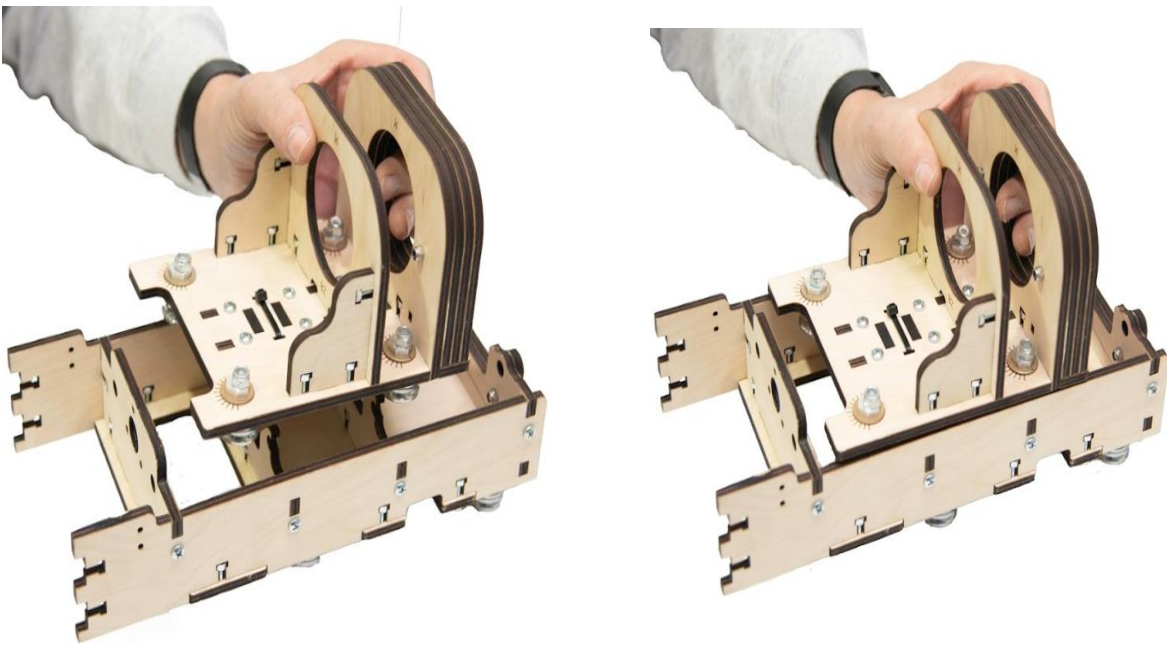

Step 2

Hold the Assemblies together and carefully insert a Short Rail through the Upper Rail Support, threading it behind the upper SG20U Bearing as shown. Gently thread the Z Rail through the Rail Support and behind the lower SG20U Bearing, through the second Rail Support, finally seating the Rail into the Lower Rail Support and Rail Stop Assembly.

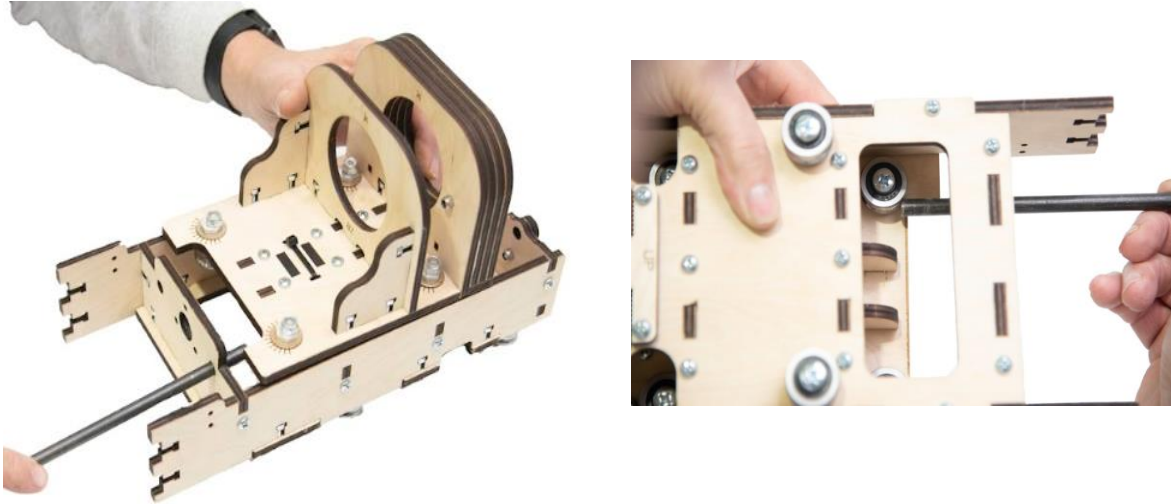

Step 3

Repeat to install the second Rail. The finished Assembly should look like this.

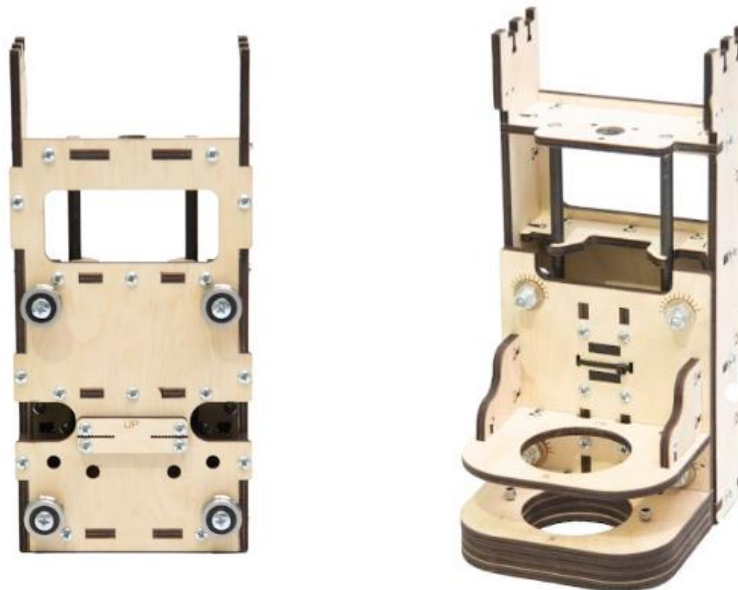

Step 4

Attach the Stepper Motor to the Z Stepper Motor Mount (Y1) using four M3 x 10 Machine Screws. Note: The Stepper Motor wires are facing towards the protrusion.

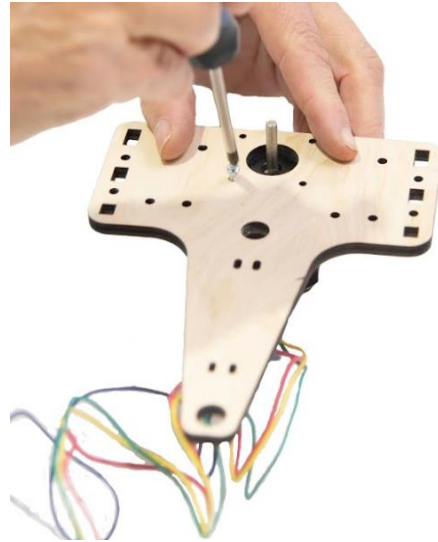
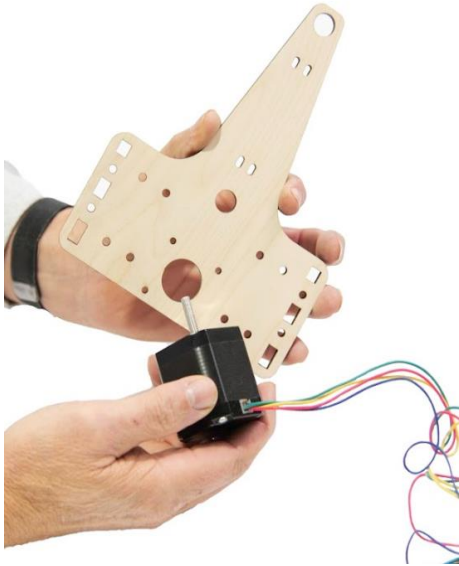

Step 5

Thread the Stepper Motor wiring harness through the Motor Mount as shown.

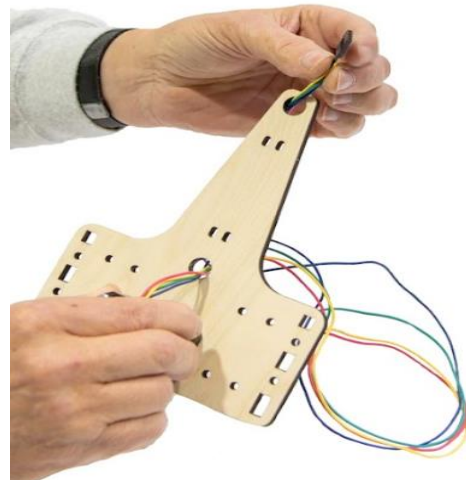
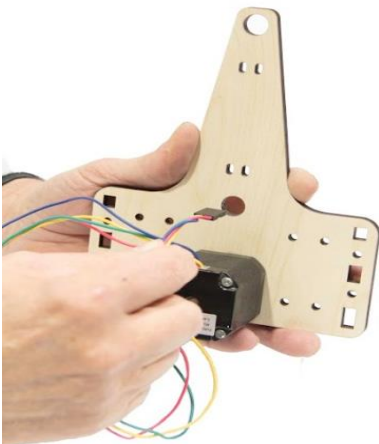

Step 6

Slide the 626-2RS Bearing(ZD3) onto the shaft of the ACME Rod, next, insert 2 Shim Washers and secure in place with the 6mm Split Locking Collar by holding the Locking Collar tightly against the Bearing, then tighten the Set Screw as shown.



Step 7

Insert the ACME Rod through the hole in the Rail Top Support and thread into the ACME Nut as shown.



Step 8

Place the Bearing Retainer Plate (Y3) over the Bearing and secure in place with three M4 x 16 Machine Screws, Bearing Retainer Washers and Lock Nuts. **[NOTE: Washers must be placed so that they cover the Outer Bearing Race to secure it in place as shown. Once installed, spin the ACME Rod to confirm the Washers do not interfere with the rotation of the Locking Nut.]**

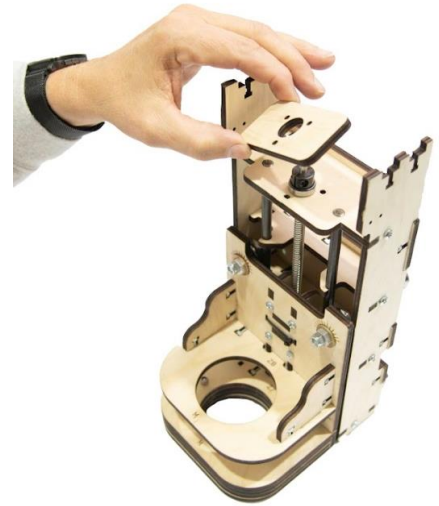

Bearing Outer Race

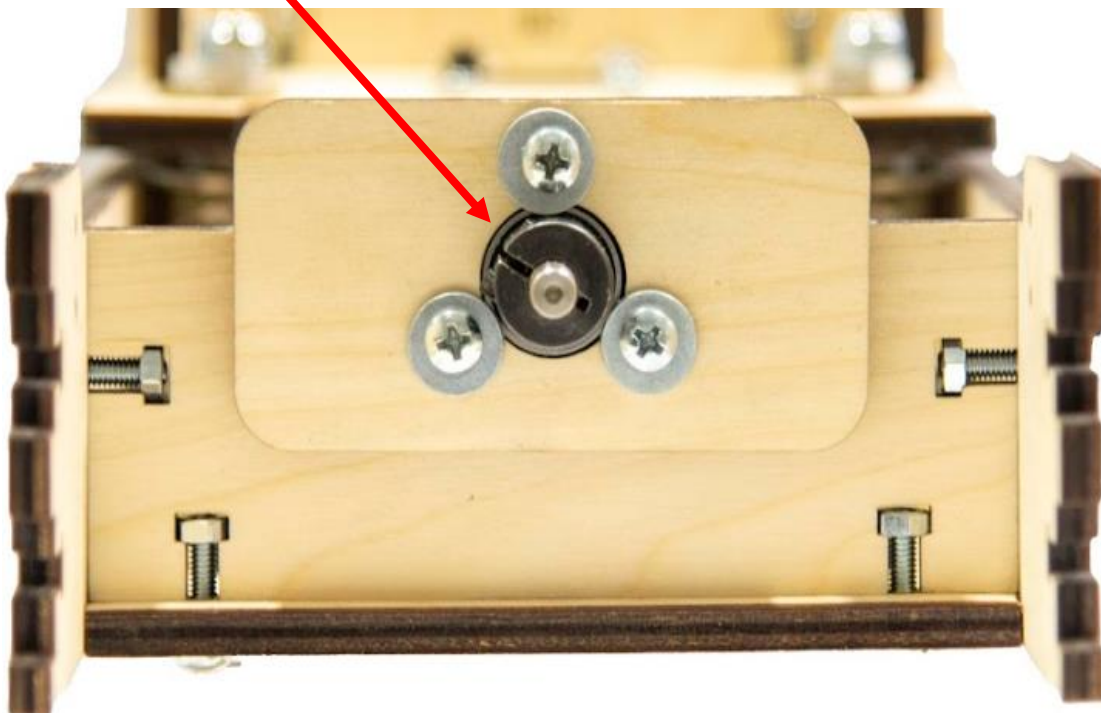

Step 9

Slide the Aluminum Helical Coupler(ZD5) over the shaft of the Stepper Motor. Make sure the Set Screw fits against the flat of the Stepper Motor Shaft. Gently snug the Set Screw to keep it from rotating off the flat but loose enough so that it can slide up and down.

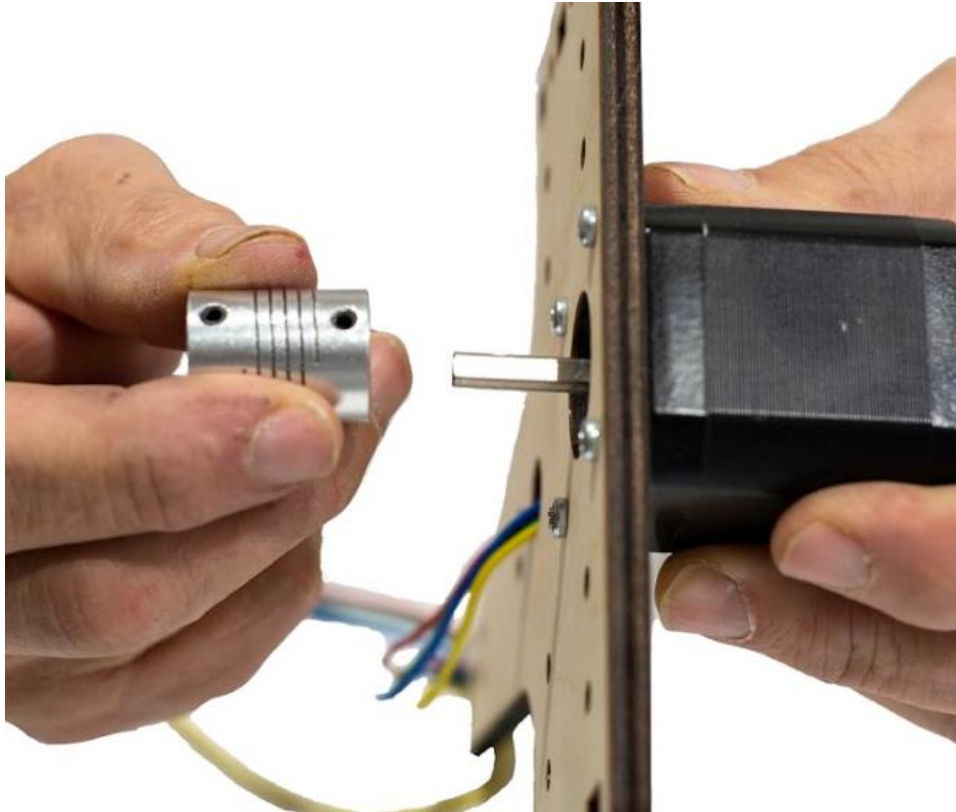

Step 10 Slide the Aluminum Helical Coupler so that it is centered top and bottom between the Locking Collar and bottom of the Z Stepper Motor Mount and tighten the upper and lower Set Screws. Secure the Z Motor Mount to the tabs of the Y Carriage Assembly using four M4 x 16 Machine Screws and Nuts.

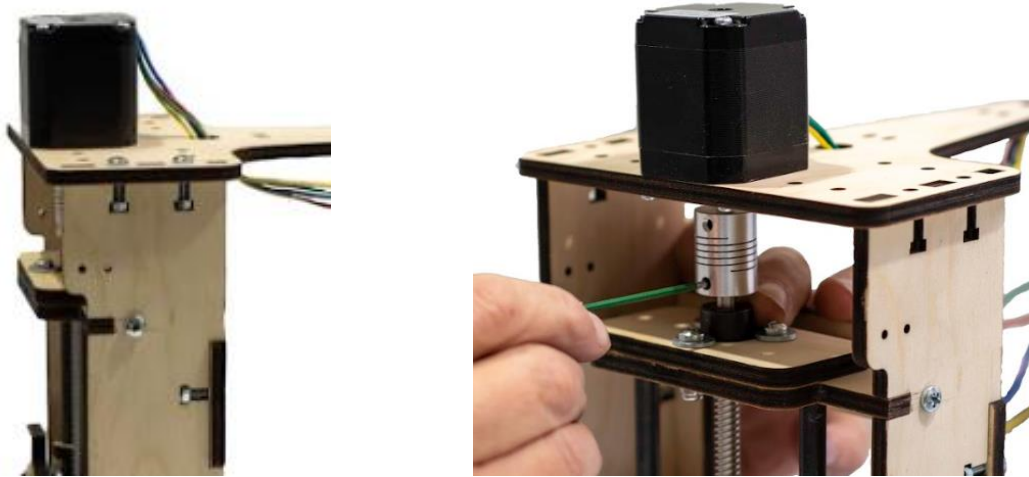

Step 11 Attach the Z Carriage Home Switch in the upper left inside corner of the Y-Carriage Assembly using two M 2.5 Machine Screws and Lock Nuts as shown. **Note: Do not overtighten the Screws.**

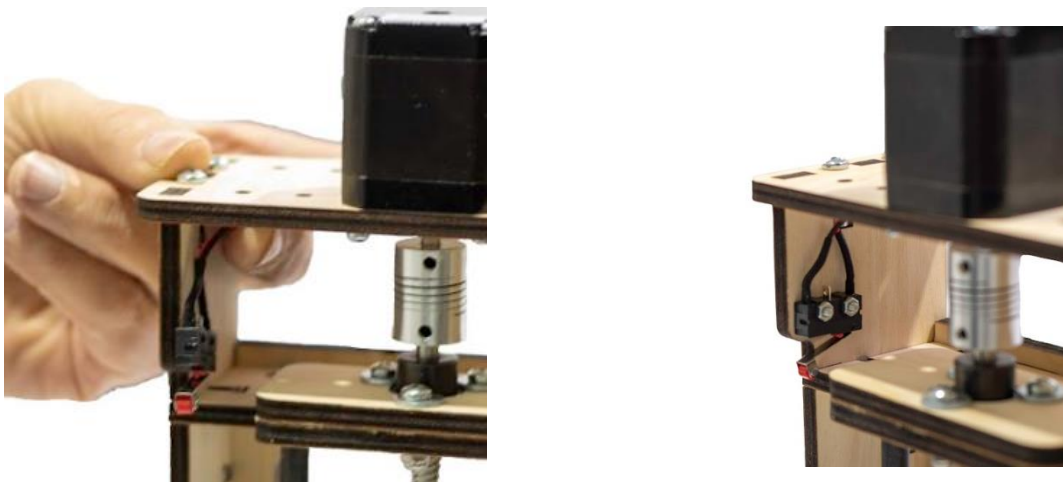

Step 12 Route the Home Switch Wires as shown below.

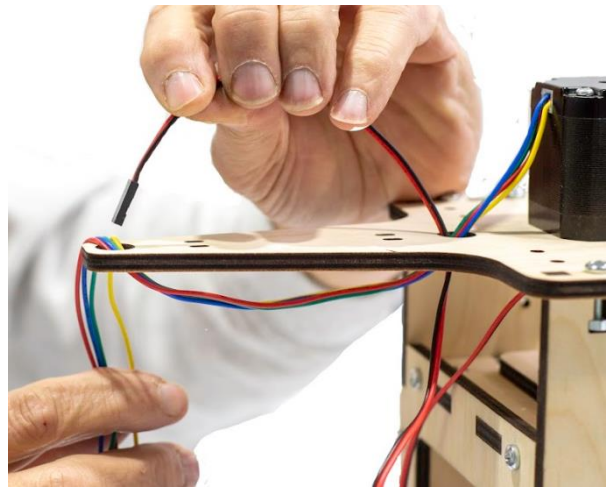
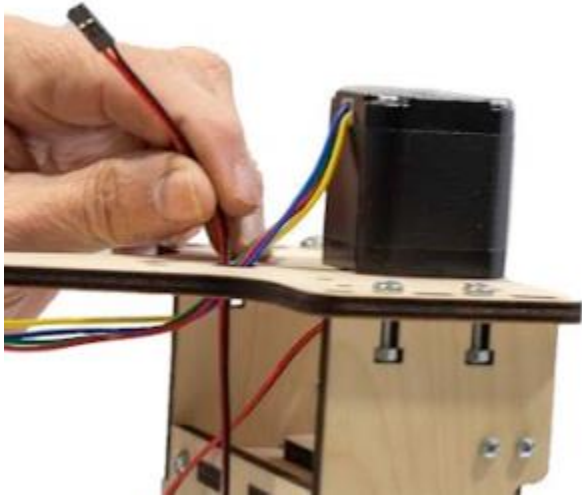



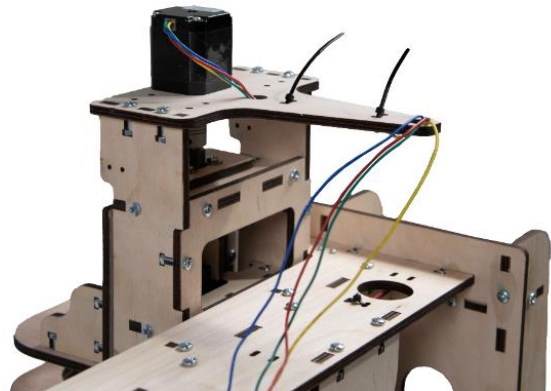
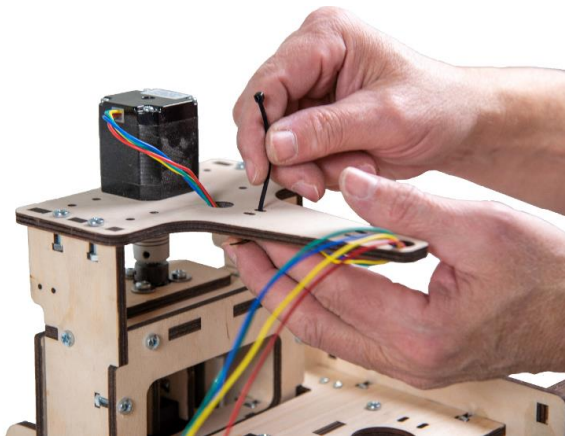

Step 13 Secure the Z Axis Stepper Motor wires with two Zip Ties to the Stepper Motor Mount as shown.

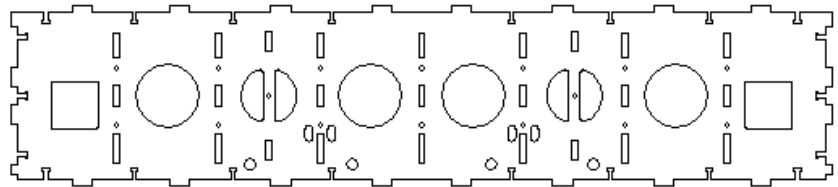
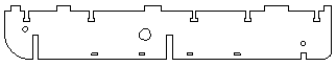

Gantry Assembly

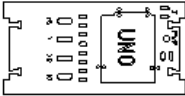
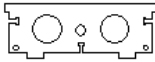
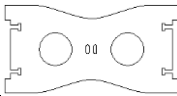
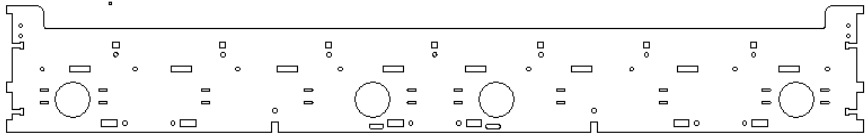
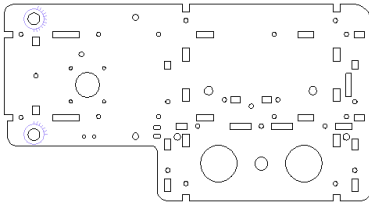
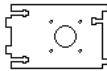

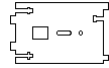
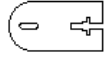



Required Wood Components





Part #	Description	Qty	Photo
G1	Gantry Frame	1	
G2	Gantry Side Support	4	
G3	Gantry Cross Brace	4	
G4	Y Rail Support	7	
G5	Controller Mount	1	
G7	Gantry Back Brace	2	
G8	Gantry Back Support	2	
G9	Gantry Top/Bottom Brace	2	
G10	Gantry Side	2	
G11	Y Stepper Motor Mount	1	

G12	Y Belt Idler Mount	1	
G13	Y Belt Adjuster	1	
G14	Gantry Side Lower Brace	2	
GA1	21mm Pulley Gauge	1	

Required Hardware

Part #	Description	Qty	Photo
H37	M3 X 10 Machine Screws	12	
H39	M6 X 30 Machine Screws	8	
H27	M2.5 x 16 Machine Screws	6	
H43	M2.5 Lock Nuts	6	
H18	M6 Lock Nuts	8	
H40	Eccentric Adjustment Spacer	4	
H41	Eccentric Washer	4	
H42	Bearing Fender Washer	12	

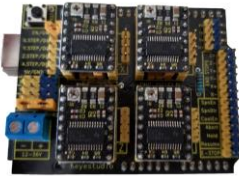
H44	SG20U Bearing	8	
H14	M4 x 16 Machine Screws	112	
H15	M4 Nuts	113	
H26	Small 4" Zip Ties	30	
H48	M5 x 30 Machine Screw	3	
H64	M5 Nut	3	
H49	M5 Lock Nuts	3	
H50	Idler Fender Washer	6	
H51	Flanged Bearing F625Z	6	
H55	GT2 Pulleys	3	
H57	Bearing Retainer Washers	1	
CB8	USB Cable	1	

CB11	Stepper Motors	3	
CB12	Power Supply with Cord	1	
H31	8" Zip Tie	1	
CB16	Controller	1	
CB13	Home Switches	3	

Illustrated Step by Step Instructions

- Step 1** Align and insert the tabs of one Gantry Side Support (G2) into the slots of one Gantry Side (G10). Secure with five M4 x 16 Machine Screws and Nuts as shown. NOTE: Make sure the side with the alignment markings is facing up.

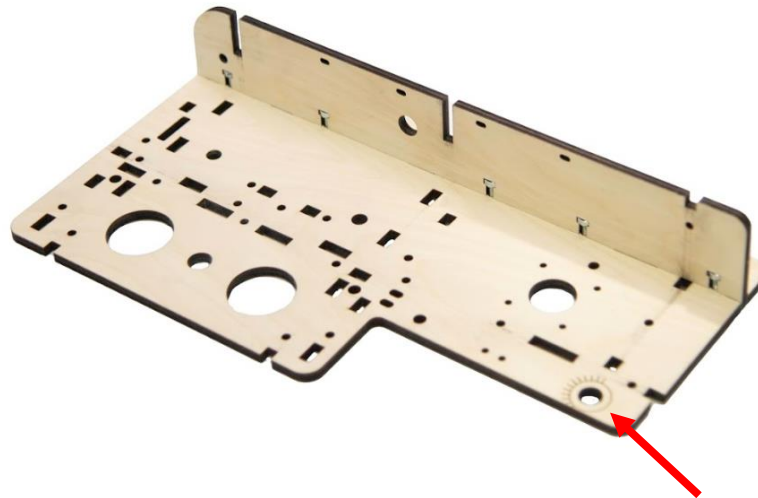

Alignment Marks

- Step 2** Align and insert the tabs of the second Gantry Side Support (G2) to the slots of the Gantry Side (G10) and secure with five M16 Machine Screws and Nuts as shown.

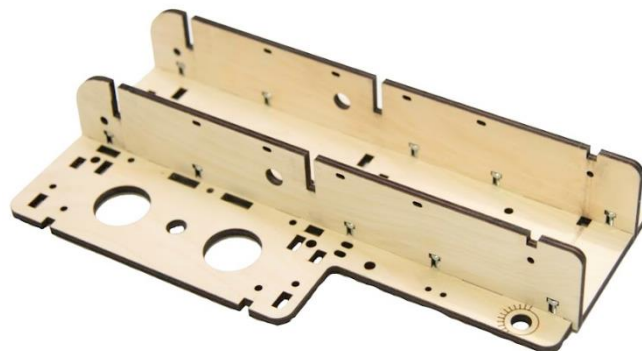

Step 3

Align and insert the tab and slots of the Gantry Side Lower Brace (G14) and secure with three M4 x 16 Machine Screws and Nuts as shown.

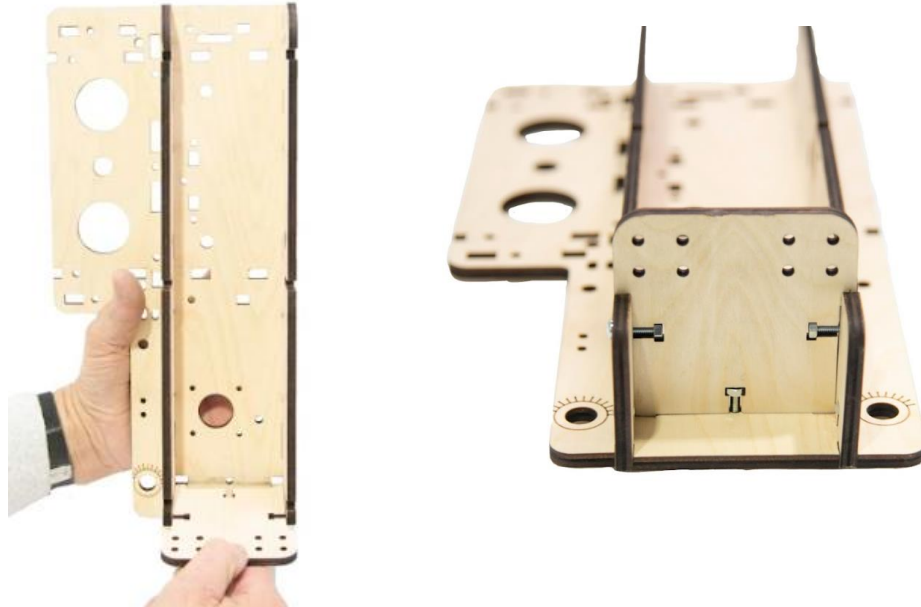

Step 4

Align and insert the tab and slots of one Gantry Cross Brace (G3) as shown and secure in place with two M4 x 16 Machine Screws and Nuts.

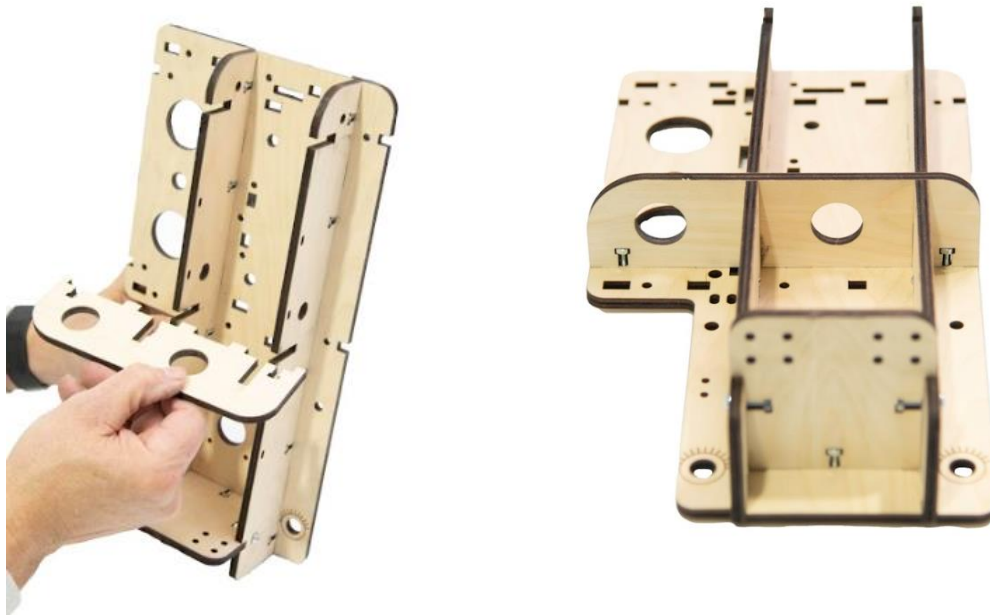

Step 5 Align and insert the tab and slots of the second Gantry Cross Brace (G3) as shown and secure in place with two M4 x 16 Machine Screws and Nuts.



Step 6 Repeat process to assemble second side. [**NOTE: Both sides will mirror each other as shown**].





Prior to putting the Gantry Assembly together, note that the four ½” (12mm) holes at the bottom of the Gantry Frame (G1) must be oriented on the bottom of the Gantry Assembly. They provide access to adjust the Y Carriage Bearings in a later step.

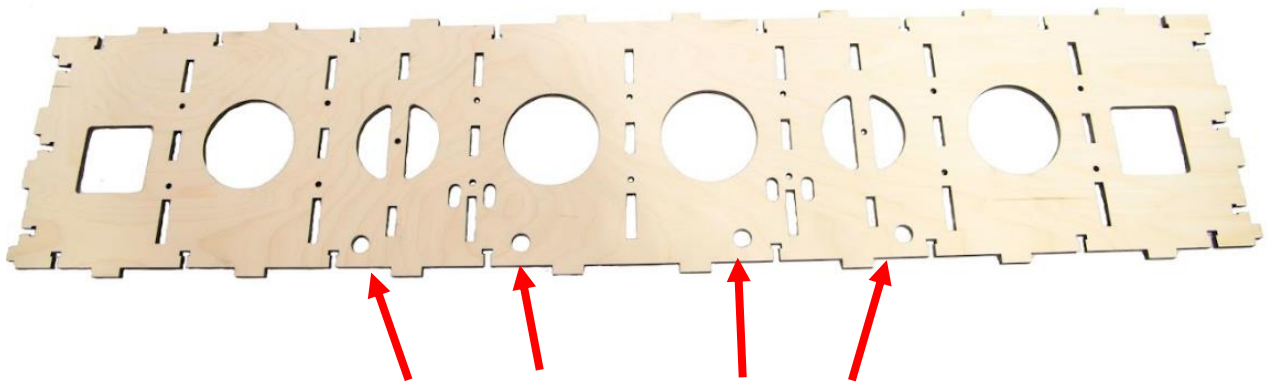

Bearing Adjustment Access Holes

Step 7

Align and insert the tabs of the seven Y Rail Supports (G4) into the slots in the (G1) Gantry Frame and secure with fourteen M4 x 16 Machine Screws and Nuts.



Finished Assembly should look like this.

Step 8

Align and insert the tabs of the Gantry Frame Assembly into the slots in the Gantry Bottom Brace (G9) and secure with fifteen M4 x 16 Machine Screws and Nuts as shown. **NOTE: The Bearing Adjustment Access Holes in the Gantry Frame are at the bottom.**

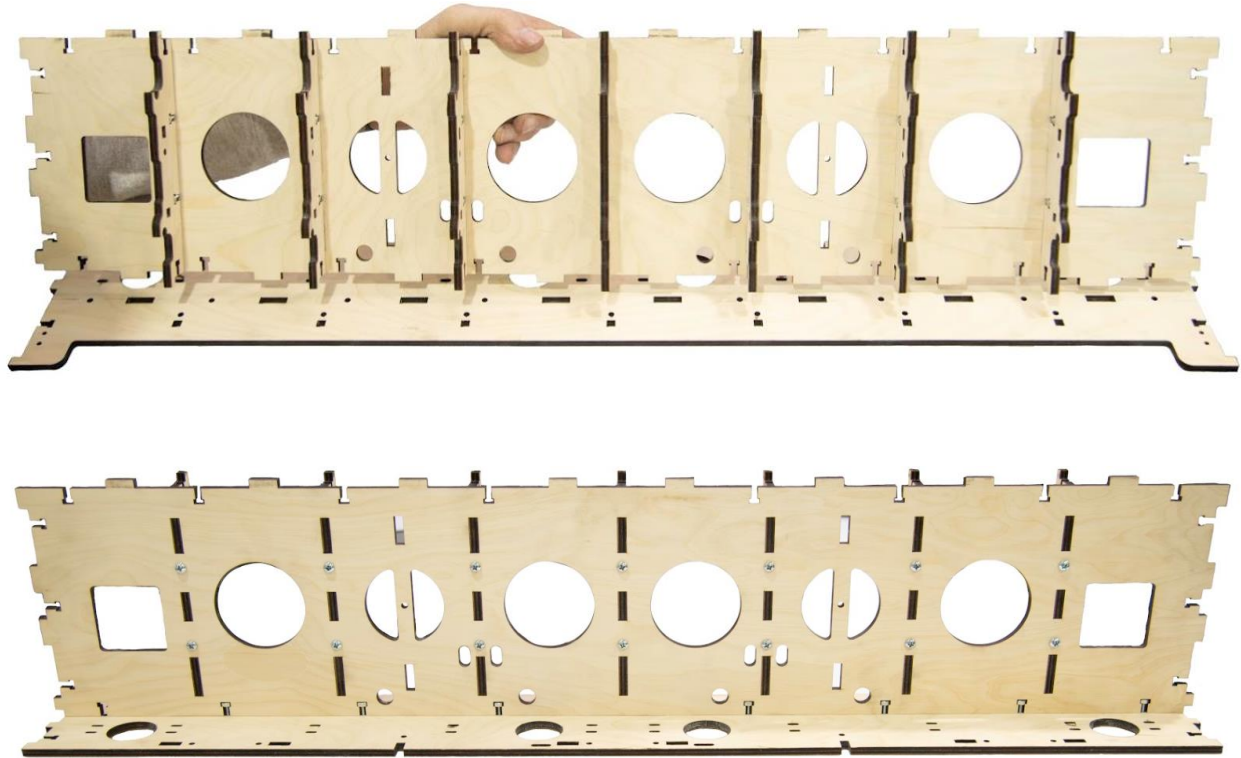

Step 9

Align and insert the tabs of the Gantry Back Support (G8) into the slots of the Gantry Frame Assembly and secure with two M4 x 16 Machine Screws and Nuts. Repeat at the opposite end of the Gantry as shown.



Left Side



Right Side

Step 10 Align and insert the tabs of the Controller Mount (G5) into the slots of the Gantry Frame Assembly and secure with two M4 x 16 Machine Screws and Nuts as shown.

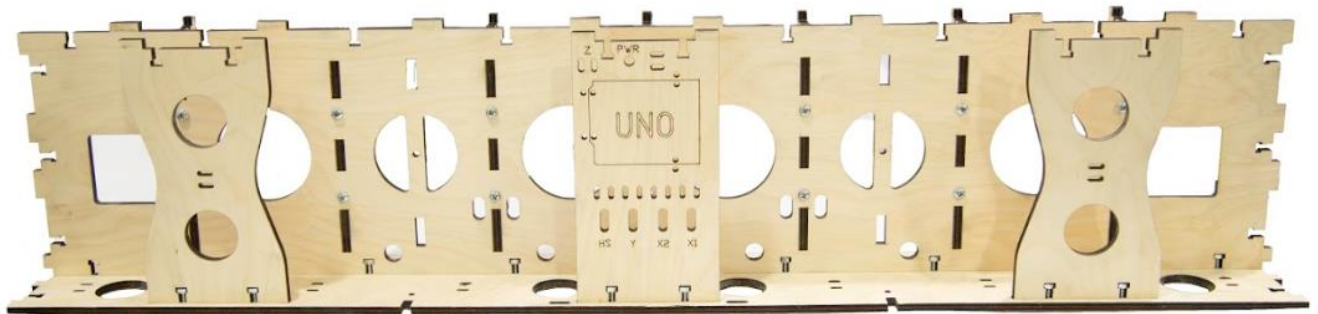
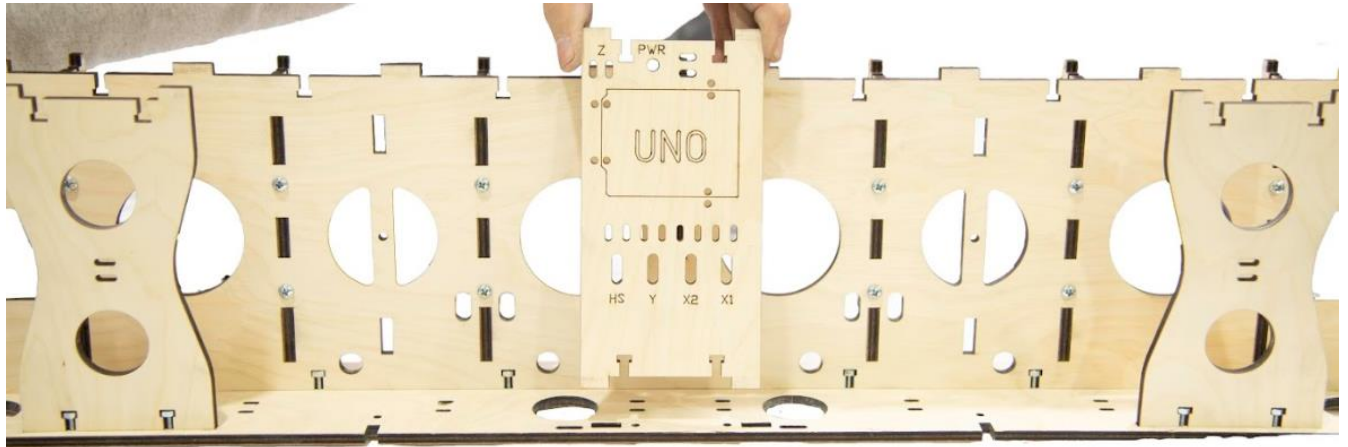

Step 11 Align and insert the tabs of the Gantry Frame Assembly into the slots of the Gantry Top Brace (G9) and secure with twenty-one M4 x 16 Machine Screws and Nuts as shown.

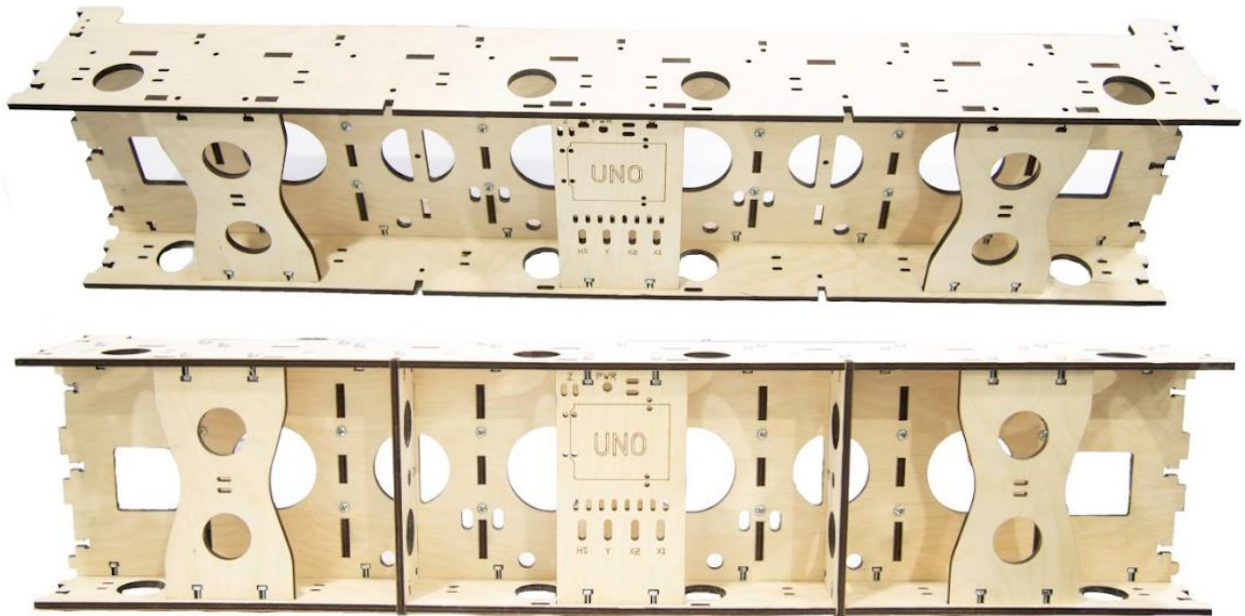

Step 12 Align and insert the tabs of the Gantry Back Brace (G7) into the slots of the Gantry Frame Assembly and secure with three M4 x 16 Machine Screws and Nuts as shown. Repeat to install the second Brace.

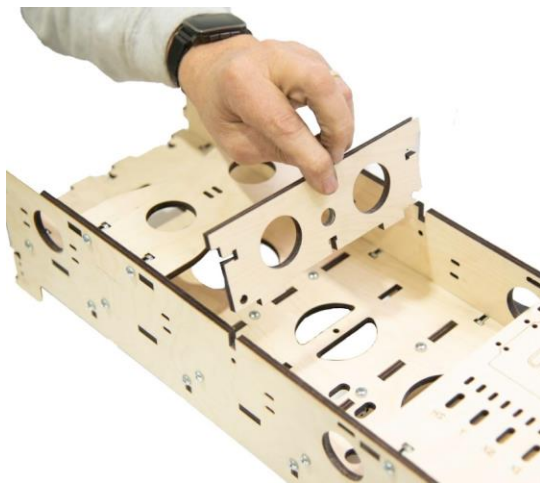

Step 13 Build three Idler Bearing Sub-Assemblies.

- 13a** Slide two F625Z(H51) Flanged Bearings on a M5 x 30 Machine Screw as shown. NOTE: install the flanges of the Bearings so that each flange is oriented to the outside from the other as shown.



- 13b** Thread a M5 Nut onto the Machine Screw snug against the Bearings as shown.



- 13c** Slide an Idler Fender Washer onto the Machine Screw against the M5 Nut.



- 13d** Insert the Bearing assembly through Y Belt Idler Mount (G12) and secure with an Idler Fender Washer and M5 Lock Nut as shown.

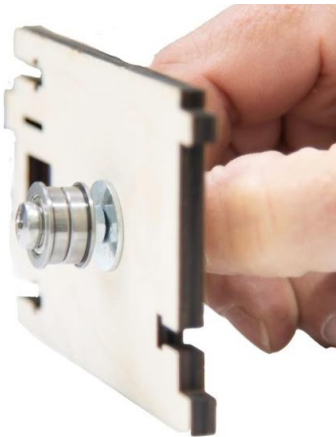

- 13e** Place a 1 ½" strip of painter's tape on one side of the Y Belt Adjuster. Insert a M4 Nut and a Bearing Retainer Washer in the appropriate slots and cover with another length of tape.



- 13f** Insert the M5 Lock Nut into the hex shaped hole in the Y Belt Adjuster (G13). Secure in place by threading an 8 inch Zip Tie through the slots as shown. NOTE: The Idler Support Assembly should slide up and down the Y Belt Adjuster while keeping the Lock Nut secure.



Step 14 Align the Idler Adjustment Assembly into the slots of the Gantry Frame Assembly as shown. Secure the Adjustment Assembly in place with one M4 Machine Screw and Nut as shown. In the photo below, the Bearing Adjustment Access Holes are oriented to the top to simplify installation.

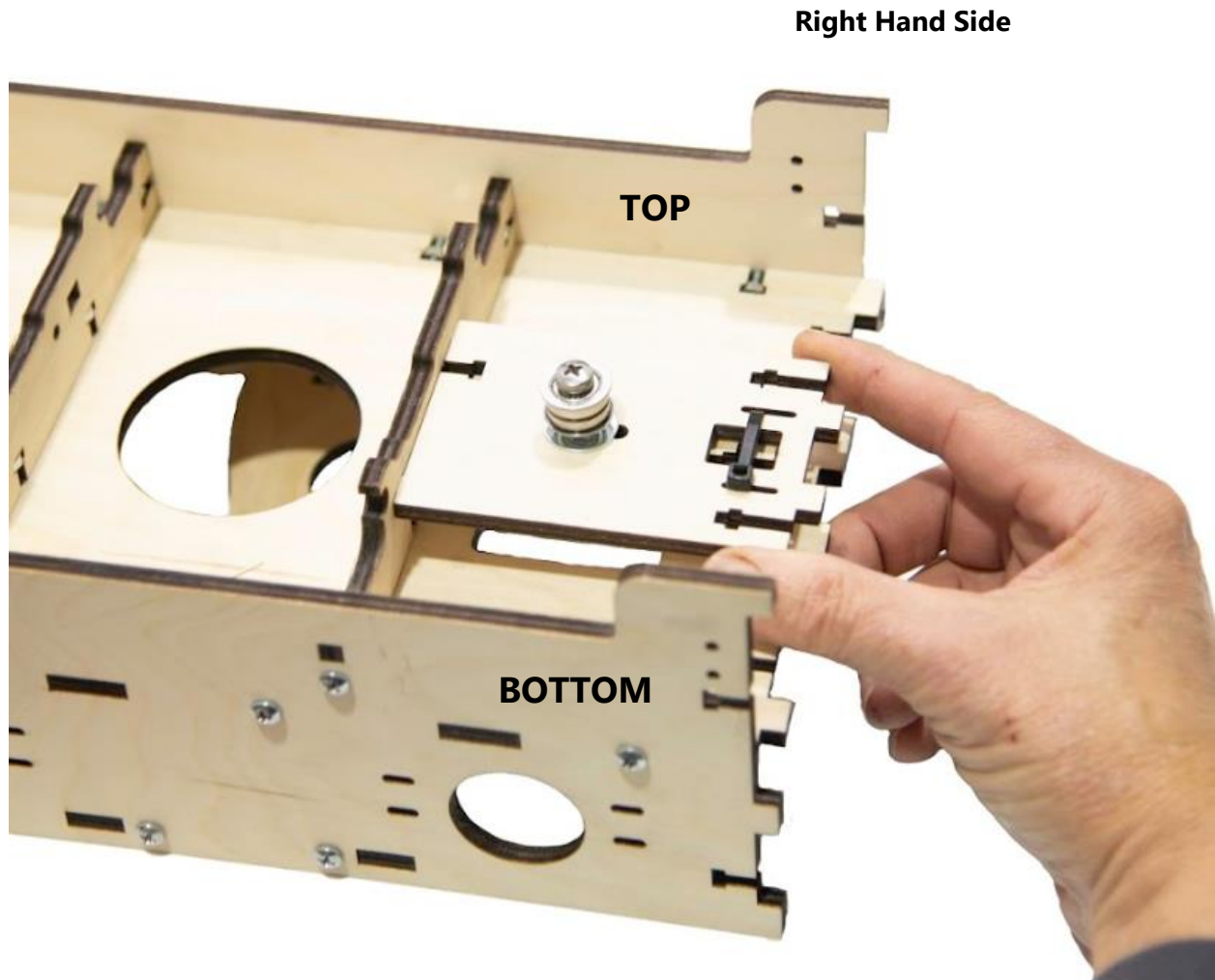

Step 15 Align and insert the tabs of the Y Stepper Motor Mount (G11) into the slots of Gantry Frame Assembly and secure with one M4 x 16 Machine Screw and Nut as shown. In the photo below, the Bearing Adjustment Access Holes are oriented to the bottom to simplify installation.

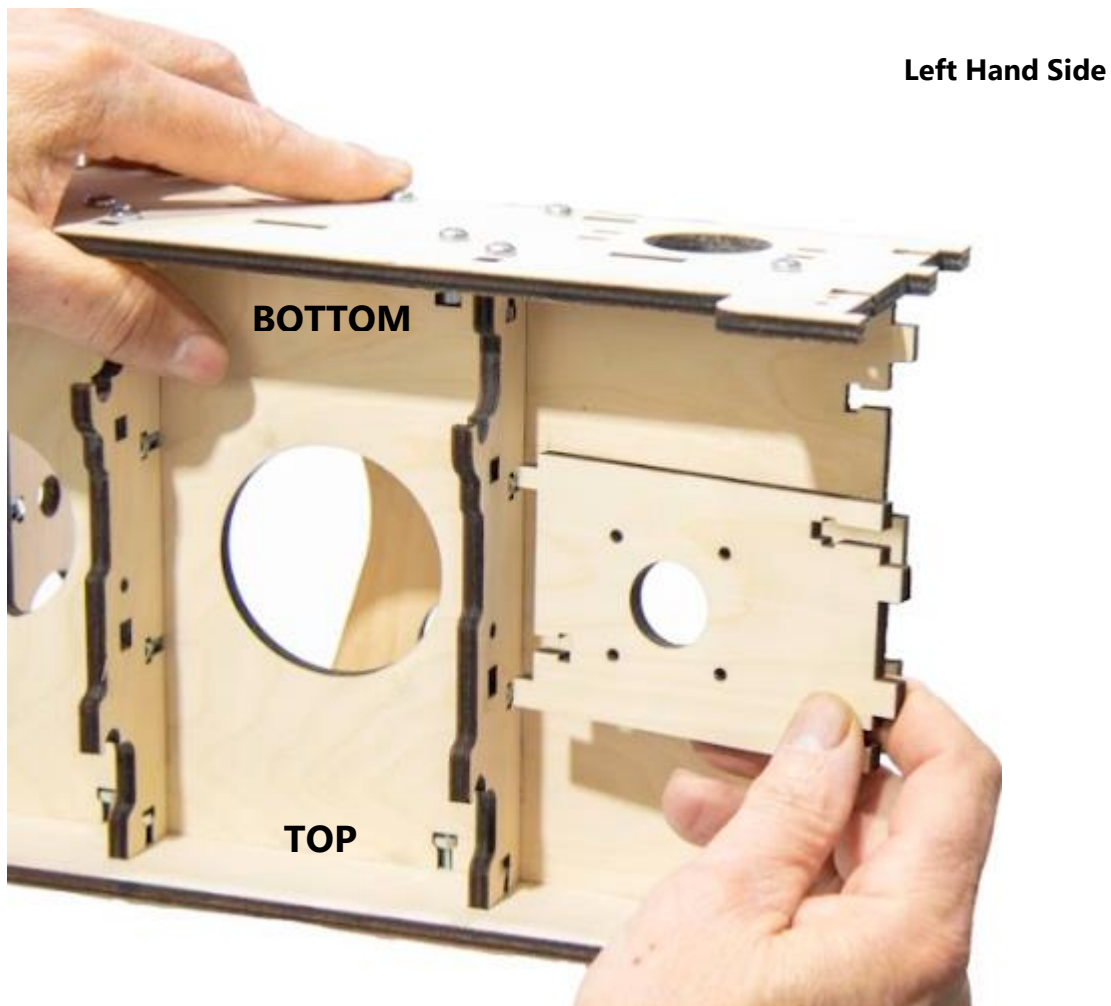

Step 16 Align and insert the tabs of the Gantry Frame Assembly into the slots of the left Gantry Side Assembly and secure with seven M4 x 16 Machine Screws and Nuts. [**NOTE: The Stepper Motor Mount will be secured in a later step**].

Left Hand Side

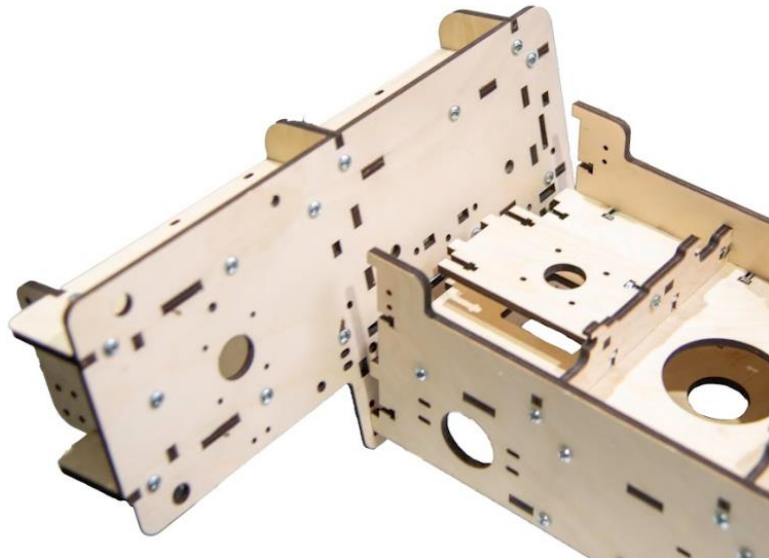

Left Front View Completed

Step 17 Align and insert the tabs of the Gantry Frame Assembly into the slots of the Right Gantry Side Assembly and secure with seven M4 x 16 Machine Screws and Nuts. [**NOTE: The Stepper Motor Mount will be secured in a later step**]. (Photo is taken from the back of the Assembly to illustrate tabs and slots).



Front View (Right Hand Side) Completed

Step 18 To install the lower Eccentric Bearing Assembly on the Gantry Side Assembly, turn the Gantry Assembly so that it is resting on the top side as shown.



18a Lower Bearing Order: M6 x 30 Machine Screw, SG20U Bearing (with hub facing toward the Bearing Washer), Bearing Washer, Plywood, Eccentric Washer, Eccentric Adjustment Spacer, secured with M6 Lock Nut. Loosely tighten the Nuts. These will be adjusted and tightened at a later step.

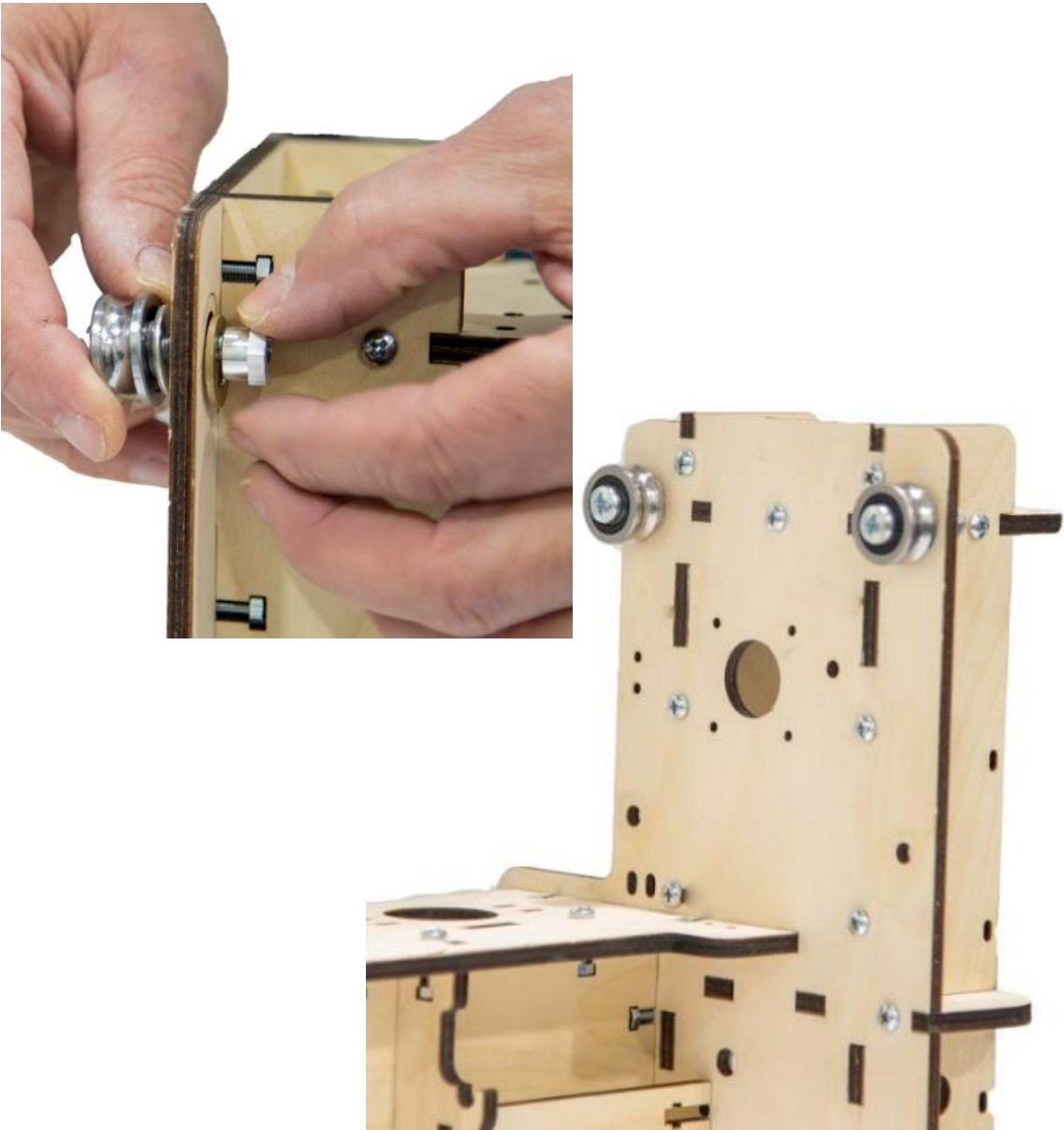

- 18b** Upper Bearing Order: M6 x 30 Machine Screw, SG20U Bearing (with hub facing toward the Bearing Washer), Bearing Washer, Plywood, Bearing Washer, secured with a M6 Lock Nut.



- 18c** Install the Idler Bearing Assembly and secure with an M5 Lock Nut as shown.



Step 19 Repeat the three steps to install the Bearing Assemblies to the opposite Gantry Side Assembly as shown.



Step 20 Install the Arduino Controller to the Gantry Assembly using four Zip Ties as shown. NOTE: when threading the Zip Ties through the attachment holes, do not tighten until all four Zip Ties are installed. Do not over-tighten. Once installed, clip the loose ends of the Zip Ties.

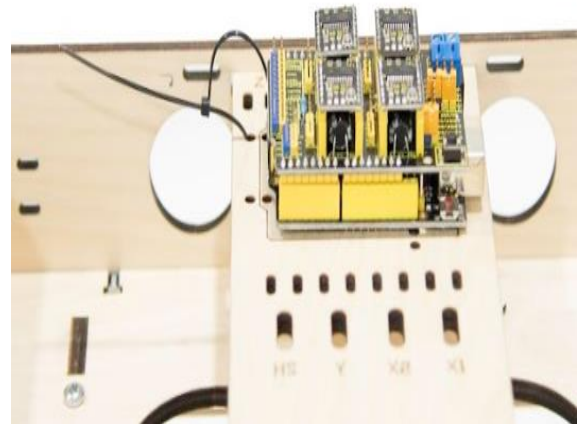

Step 21 Installing the X1 Home Switch.

- 21a** The X1 Home Switch is located to the right of the Controller when viewed from the back. Begin by labeling the pin cover using easy to read tape or other label material. Mark the label as "H X 1."



21b Route the Wire through the access hole in the bottom of the Gantry Side Assembly, through the access hole at the bottom of the Gantry Back Brace(G7), through the Home Switch (HS) opening in the Controller Mount, and thread in the Gantry Back Brace(G7).

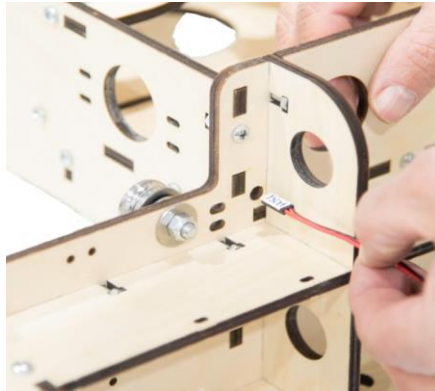

21c Connect the **X1** Plug to the "X-" Pin location on the Arduino Shield as shown.

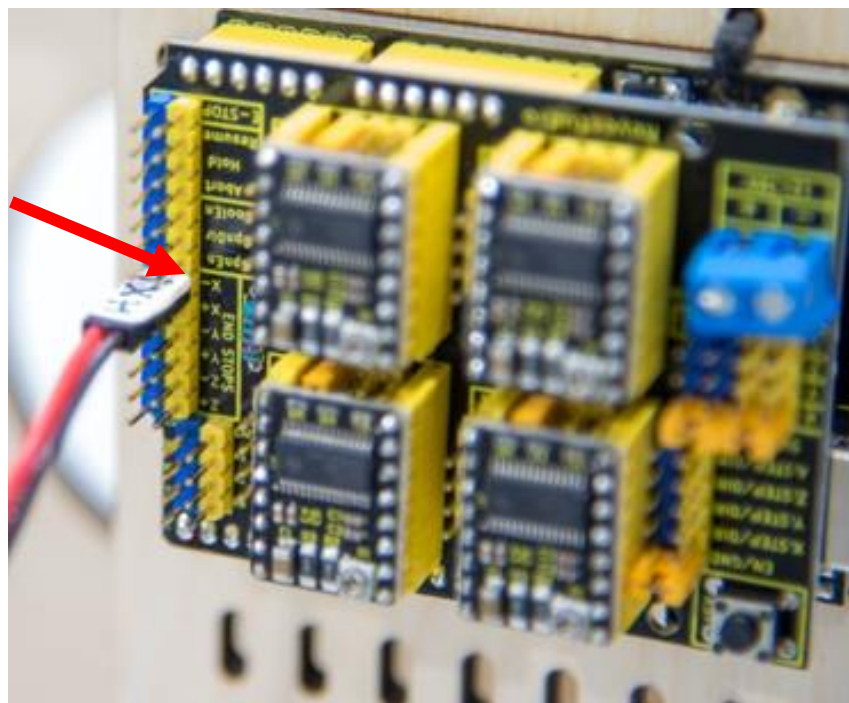

21d Mount the X1 Home Switch using two M2.5 x 16 Machine Screws and Lock Nuts. Secure the Home Switch Wires with a Zip Tie as shown.

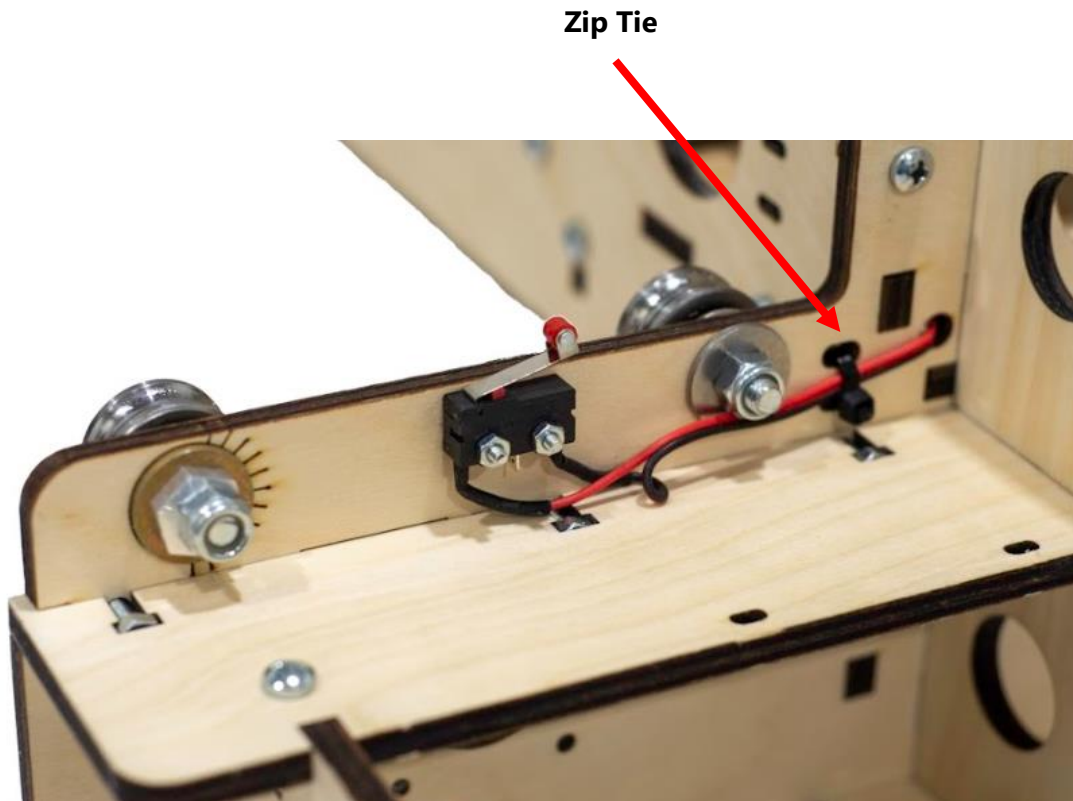

X1 Home Switch Installed.

Step 22 Installing the X2 Home Switch.

22a The X2 Home Switch is located to the left of the Controller when viewed from the back. Begin by labeling the pin cover using easy to read tape or other label material. Mark the label as "H X 2."

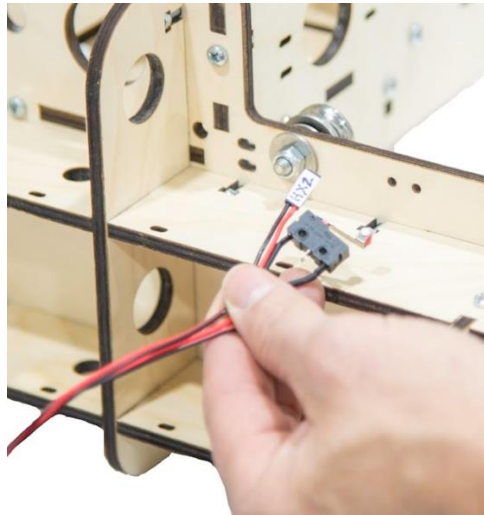

22b Route the X2 Home Switch Wire through access hole in the bottom of the Gantry Side Assembly, through the access hole at the bottom of the Gantry Back Brace(G7), and through the Home Switch (HS) opening in the Controller Mount. The X2 plug will be connected in a later step.

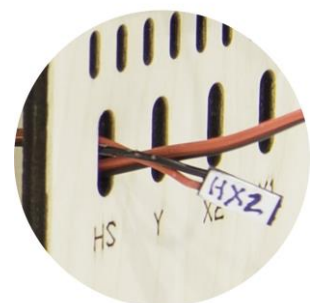
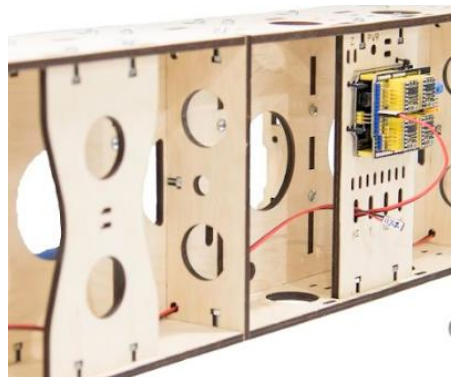

22c Mount the X2 Home Switch using two M2.5 x 16 Machine Screws and Lock Nuts. Secure Home Switch Wires with a Zip Tie as shown.

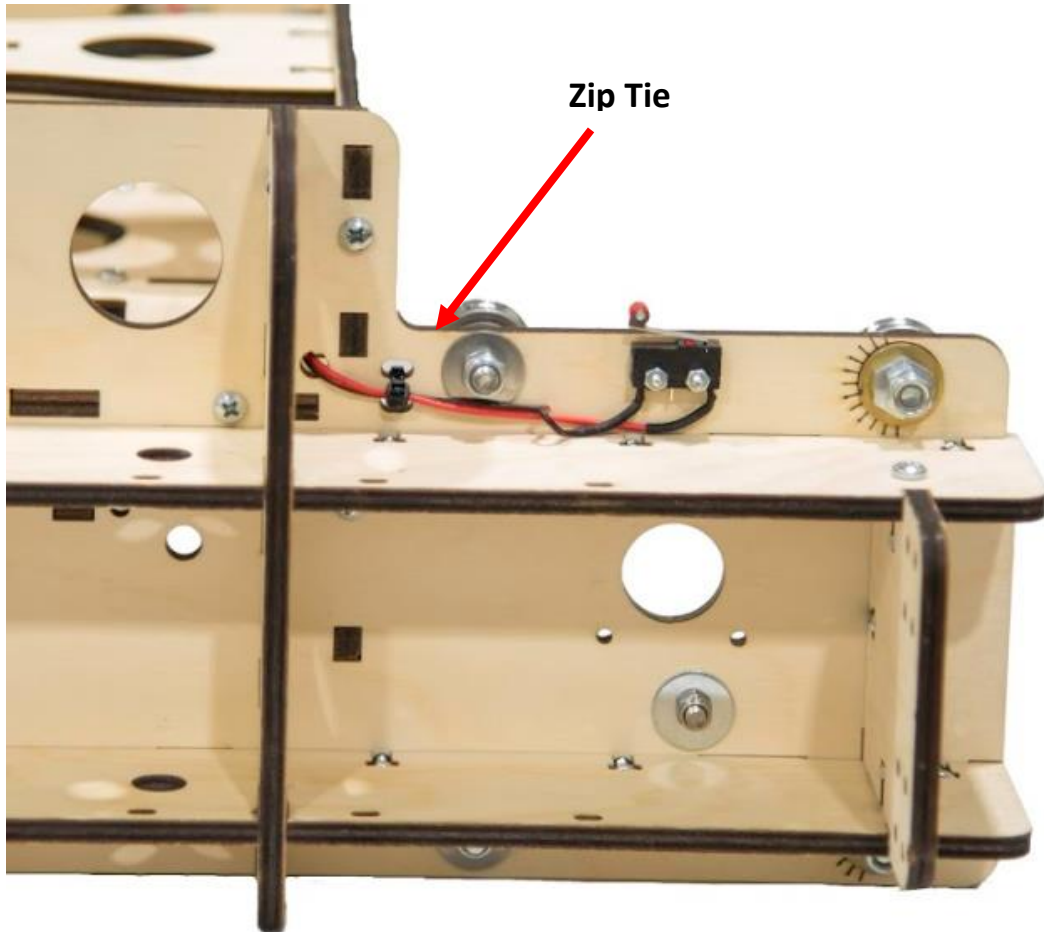

X2 Home Switch Installed

Step 23 Installing the Y Home Switch.

23a The Y Home Switch is installed in the upper left corner of the Gantry Assembly when viewed from the front or to the right of the Controller when viewed from the back. Begin by labeling the pin cover using easy to read tape or other label material. Mark the label as "H Y."

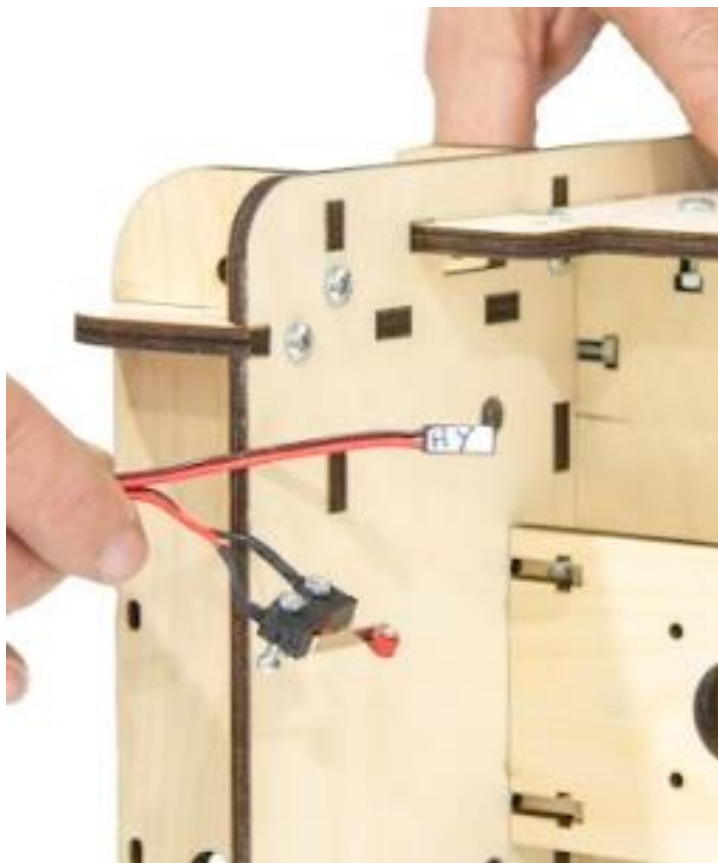

23b Route the Wire through access slot in the top of the Gantry Side Assembly, through the access hole in the top of the Gantry Side support(G2), through the Gantry Side Assembly, through the access hole in the top of the Gantry Back Brace(G7) and, through the Home Switch (HS) opening in the Controller Mount.

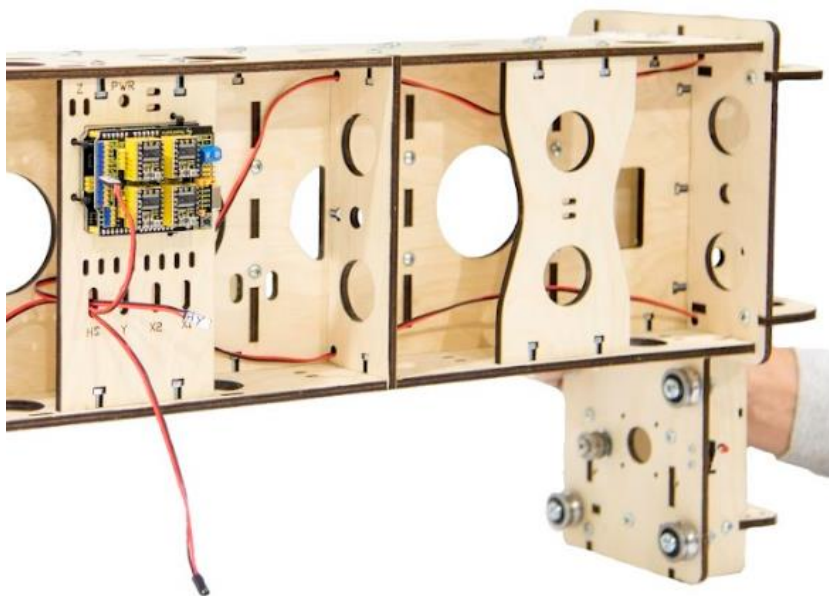
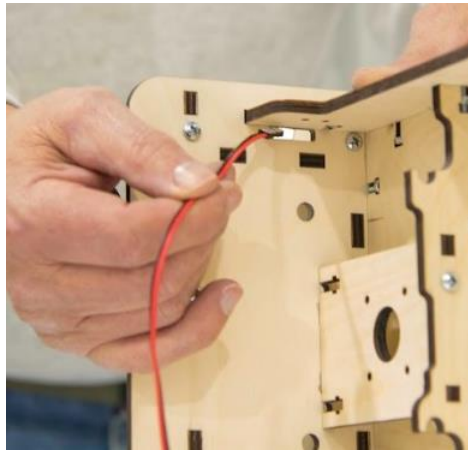

23c Mount the Y Home switch on the top left side of the front of the Gantry using two M2.5 x 16 Machine Screws and Lock Nuts as shown.



23d Connect the Y Home Switch plug to the "Y-" pin on the Arduino Controller as shown.

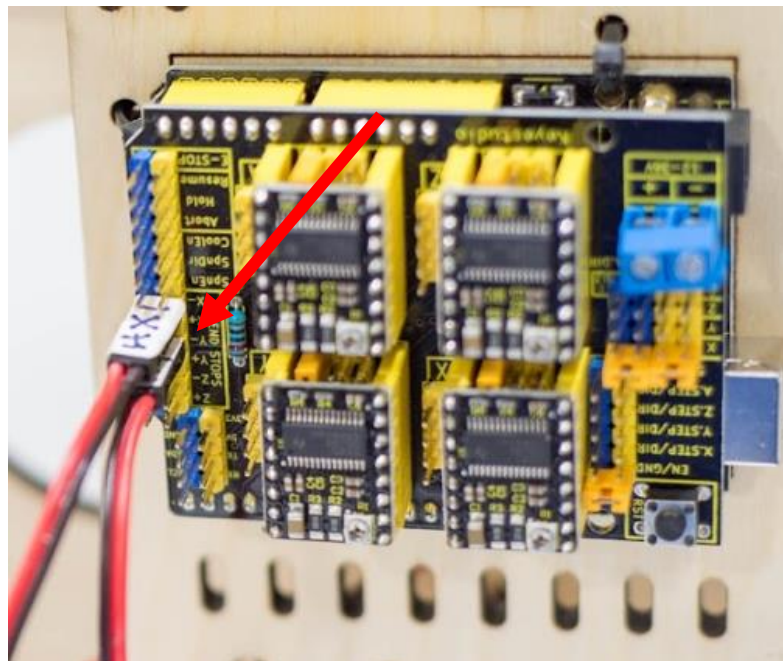

Step 24 Use the 21mm Belt Pulley Gauge(GA1) to install the Idler Pulley. Make sure the legs of the Gauge are set flat on the Motor Housing. Insert the Pulley onto the Motor shaft. Snug one of the Set Screws against the flat on the shaft and lift the top flange of the Pulley against the top of the Gauge opening as shown. Securely tighten both Set Screws using Loctite 242™ or a suitable substitute. Repeat for remaining two Stepper Motors.



Step 25 Installing the Y Stepper Motor Assembly.

25a Insert the Y Stepper Motor Assembly into the Stepper Motor Mount from the back side of the Gantry Assembly. Make sure the Stepper Motor Wires are oriented toward the top of the Gantry as shown. Secure the Stepper Motor in place with four M3 x 10 Machine Screws.

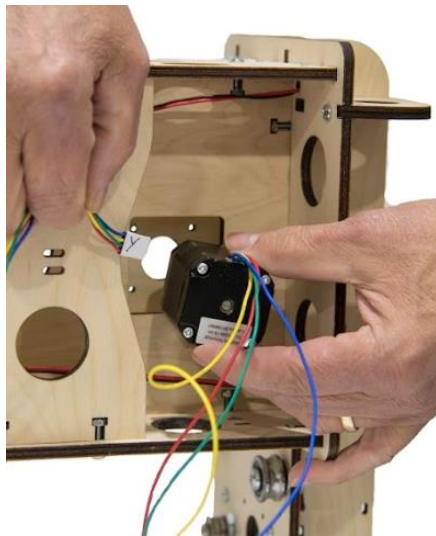

Back View

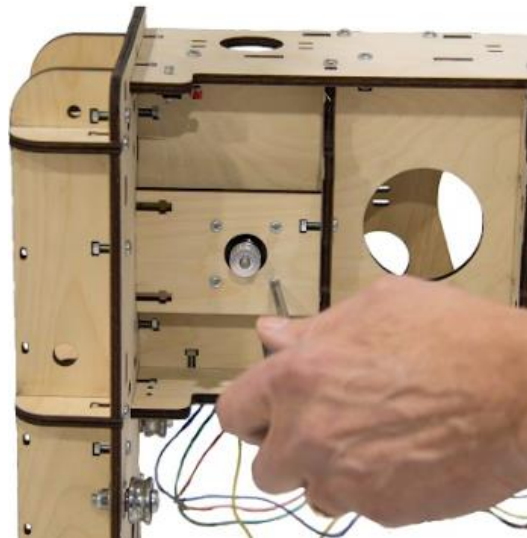

Front View

25b Route the Y Stepper Motor Wire Harness through the Back Brace(G7) and the Y Slot in the Controller Mount(G5) as shown.

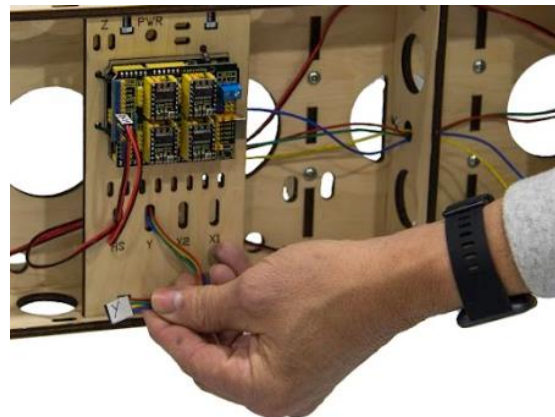

- 25c** Connect the Y Stepper Motor Plug onto the 4 Pins on the left side of the Y Driver as shown. Secure Wires to the Controller Board with a Zip Tie as shown. [**NOTE: The color code orientation must be as shown**].

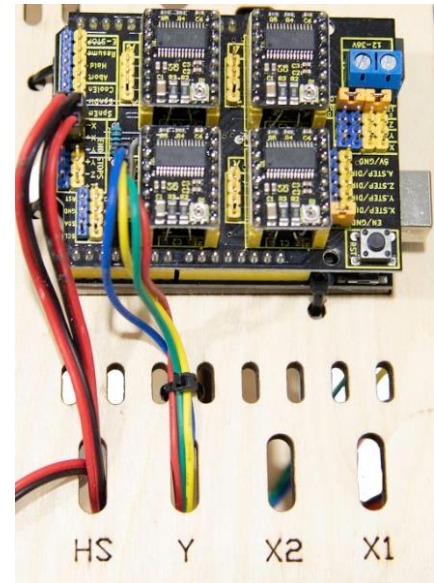
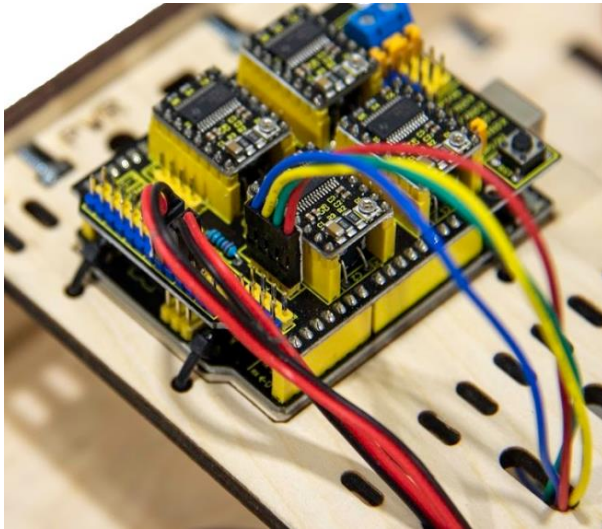

Step 26 Installing the X1 Stepper Motor Assembly.

- 26a** Insert the X1 Stepper Motor Assembly into the left side of the Gantry Assembly when facing the front, and secure with four M3 x 10 Machine Screws.

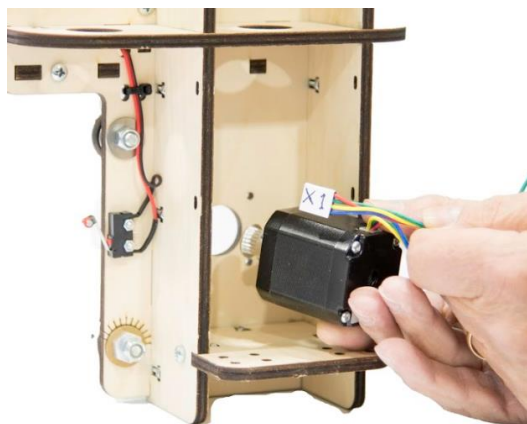

26b Route the Stepper Motor Wires up through the Gantry Side Assembly as shown.

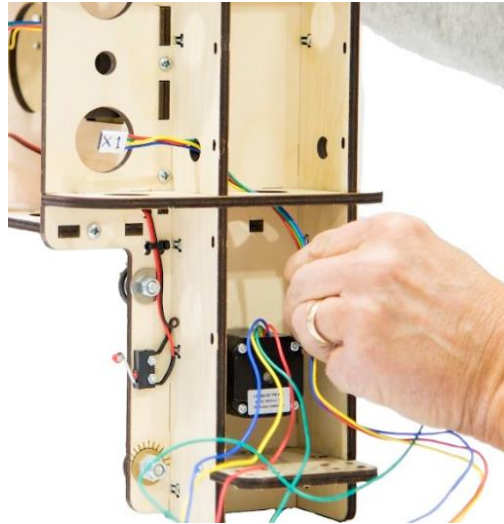

26c Continue routing the Stepper Motor Wires across the Gantry and through X1 Wire slot in the Controller Mount as shown.

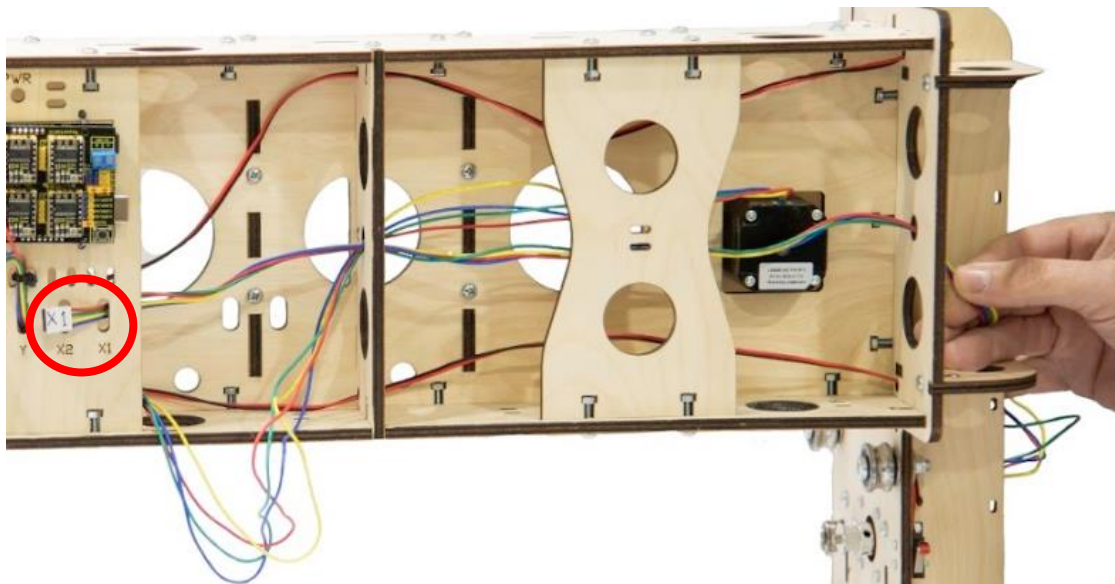

- 26d** Connect the X1 Plug to the X1 Driver pins located to the left of the Driver as shown. **[NOTE: follow the color orientation of the X1 plug as shown].**

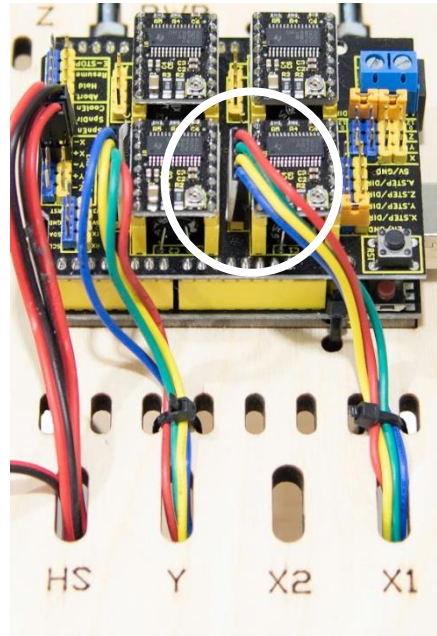

Step 27 Installing the X2 Stepper Motor Assembly.

- 27a** Insert the X2 Stepper Motor Assembly into the right side of the Gantry Assembly when facing the front and secure with four M3 x 10 Machine Screws.

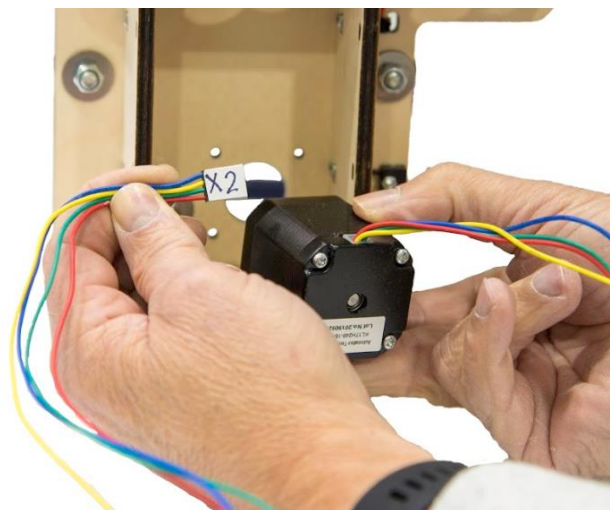

27b Route the X2 Stepper Motor Wires up through the Gantry Side Assembly as shown.



27c Continue routing the Stepper Motor Wires across the Gantry and through X2 Wire slot in the Controller Mount as shown.

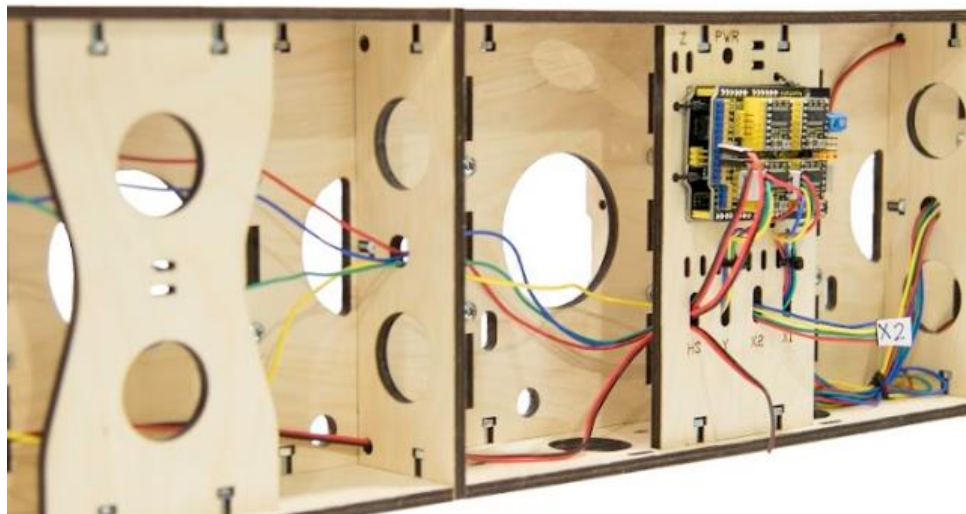

27d Connect the X2 Plug to the pins located to the left of the X2 Driver as shown.



Step 28 Installing the Power Supply and USB Cable.

28a Tuck the Power Supply(CB12) into the back of the Gantry Assembly as shown.

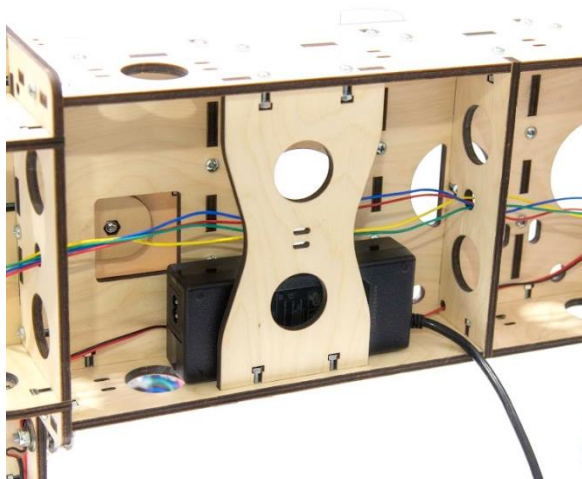

28b Route the Power Wire through the Controller Mount as shown.

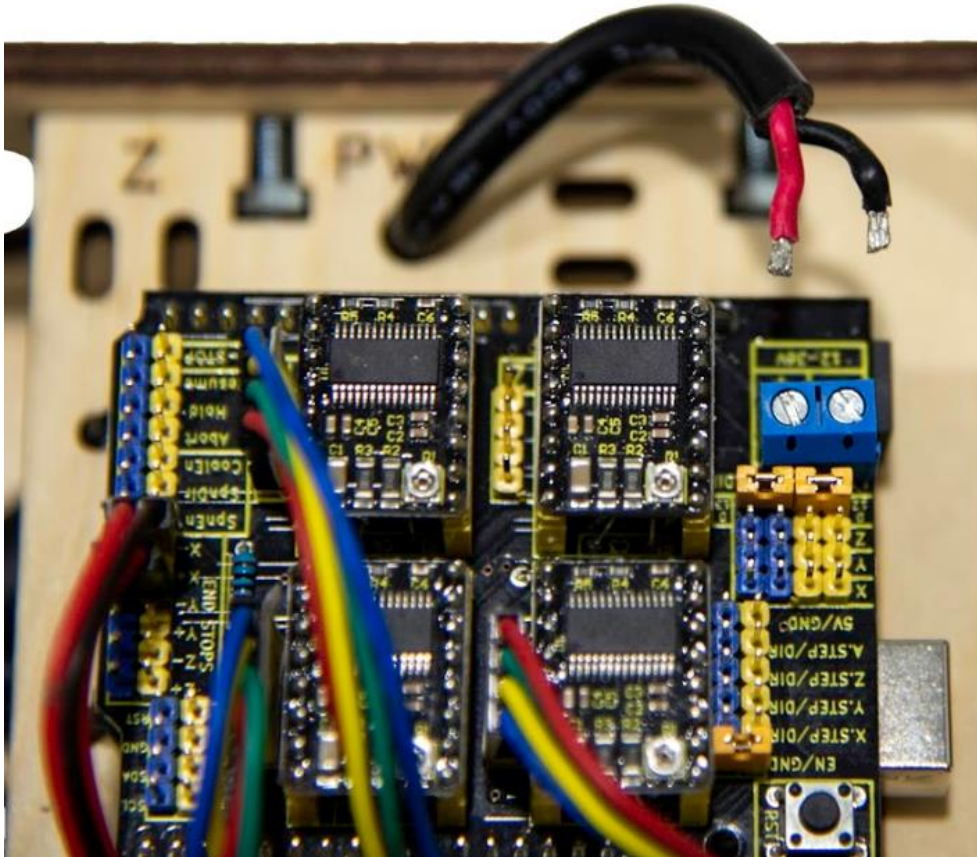



WARNING Polarity is important. Ensure proper connection as illustrated in the steps below, or you will damage your Controller.

- 28c** Attach the Power Wires to the Power Terminal on the Arduino Uno. Secure the Power Cord to the Controller Mount with a Zip Tie as shown.

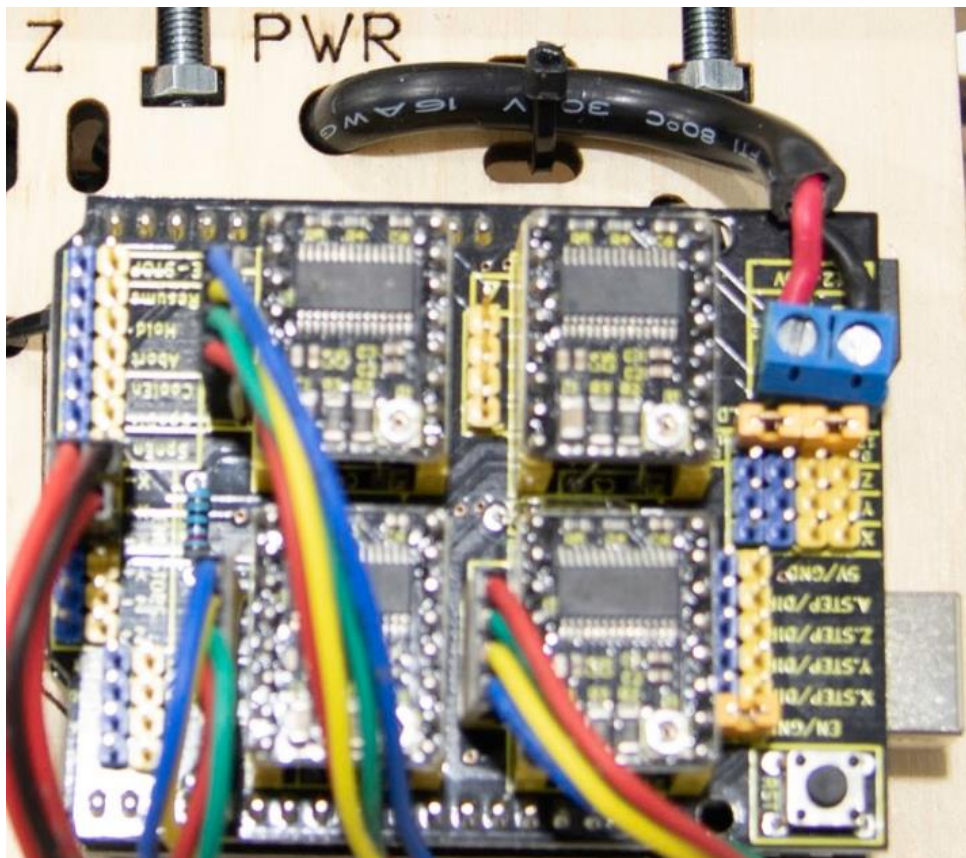

28d Route the Power Cord as shown and secure with Zip Ties shown.

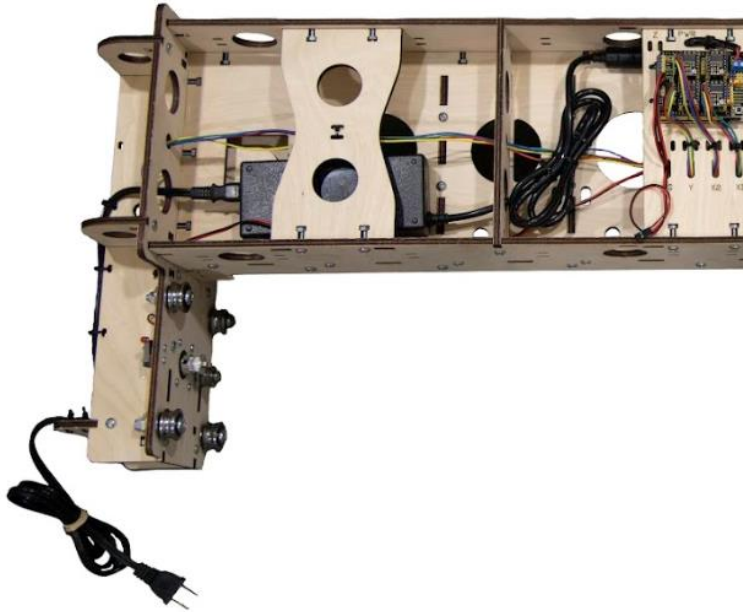

28e Connect the USB Cable to the Arduino Uno and route the Cable through the back of the Gantry and secure to the Gantry Side with Zip Ties as shown.

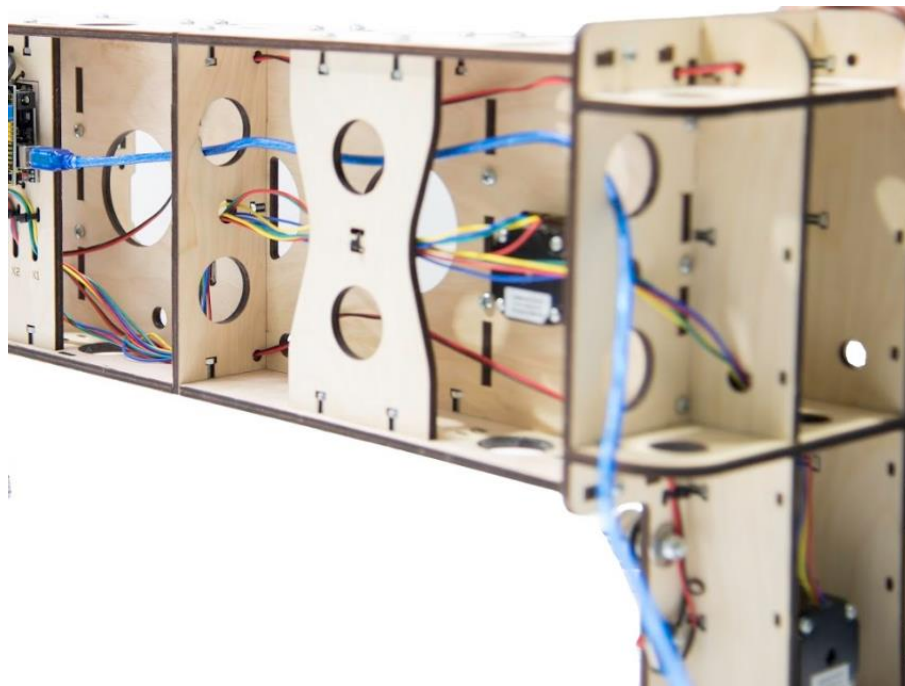



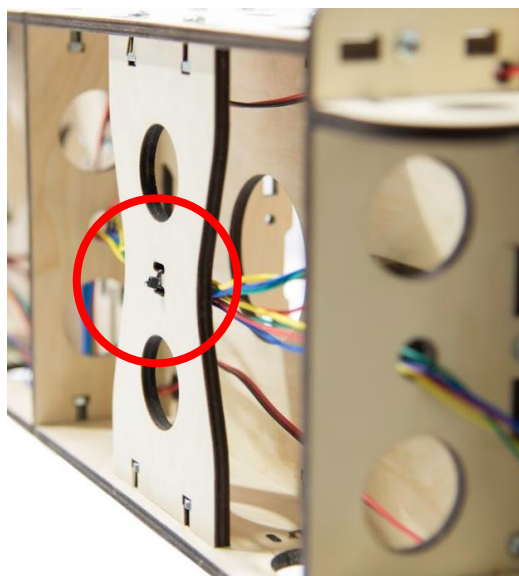

28f Wire Management: Bundle and secure the Stepper Motor Wires to the back of the Gantry Back Support with a Zip Tie as shown.

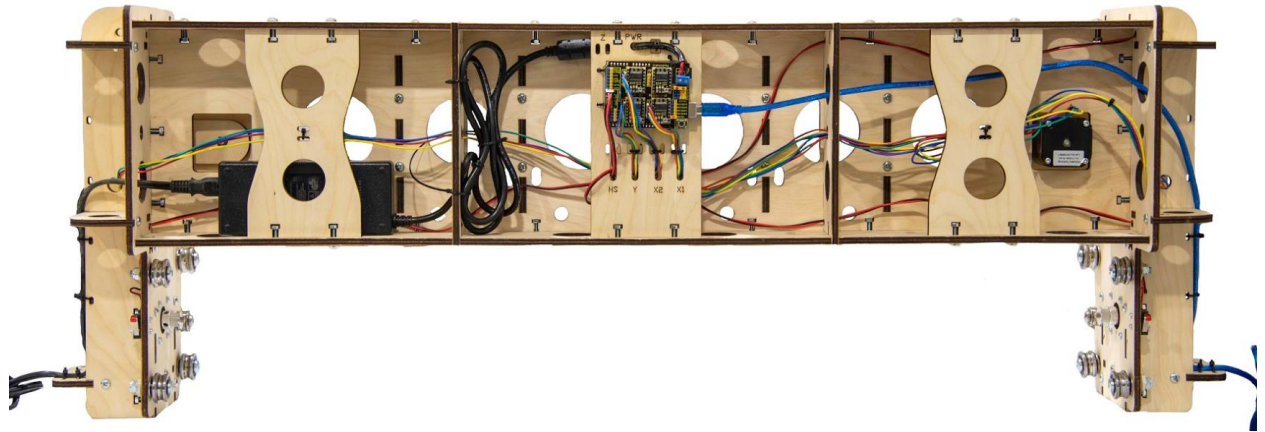



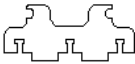
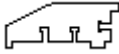
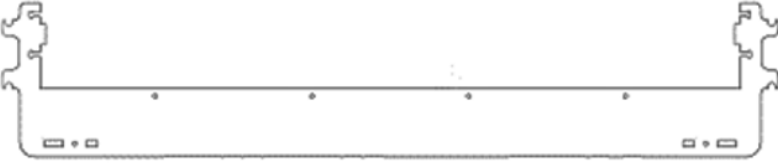
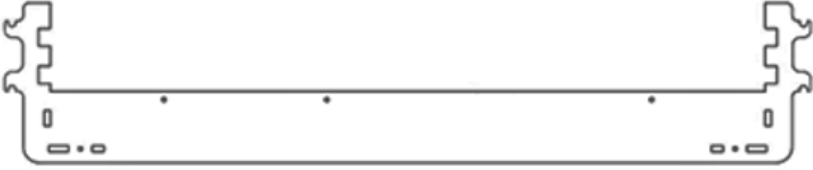
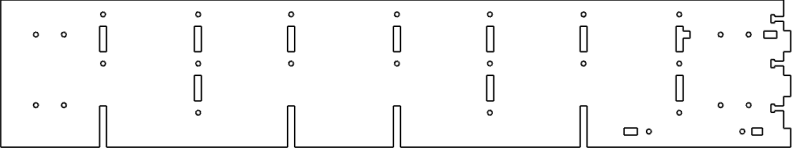
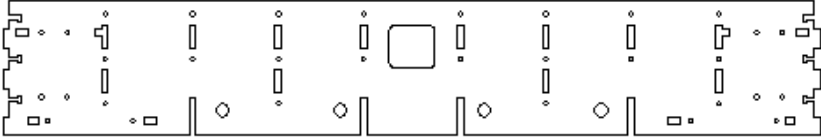

X Frame Instructions

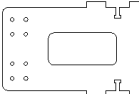
Required Wood Components

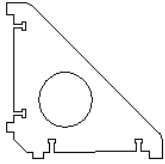
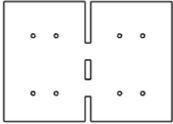
Part #	Description	Qty	Photo
X1	Rail Support	8	
X2	Frame Corner Brace	4	
X4	Frame Mid Support	4	
EX4	Frame Mid Support	1	
EX5	Frame Side Support Front	2	
X5	Frame Side Support Rear	2	
X6	Frame End Support	2	
X7	Wire Harness Support	2	

X8	Frame Corner Support	4	
EX12	Coupling Plate	2	

Required Hardware

Part #	Description	Qty	Photo
H14	M4 x 16 Machine Screw	84	
H15	M4 Nut	84	

Illustrated Step by Step Instructions

Step 1 The X Frame consists of a Front and Rear Assembly. To build the Front Assembly:

Align the tabs of the Rail Supports (X1) into the slots in the Frame Side Support Front(EX5). Secure with three M4 x 16 Machine Screws and Nuts for each Rail Support as shown. Repeat for both Frame Side Supports Front.

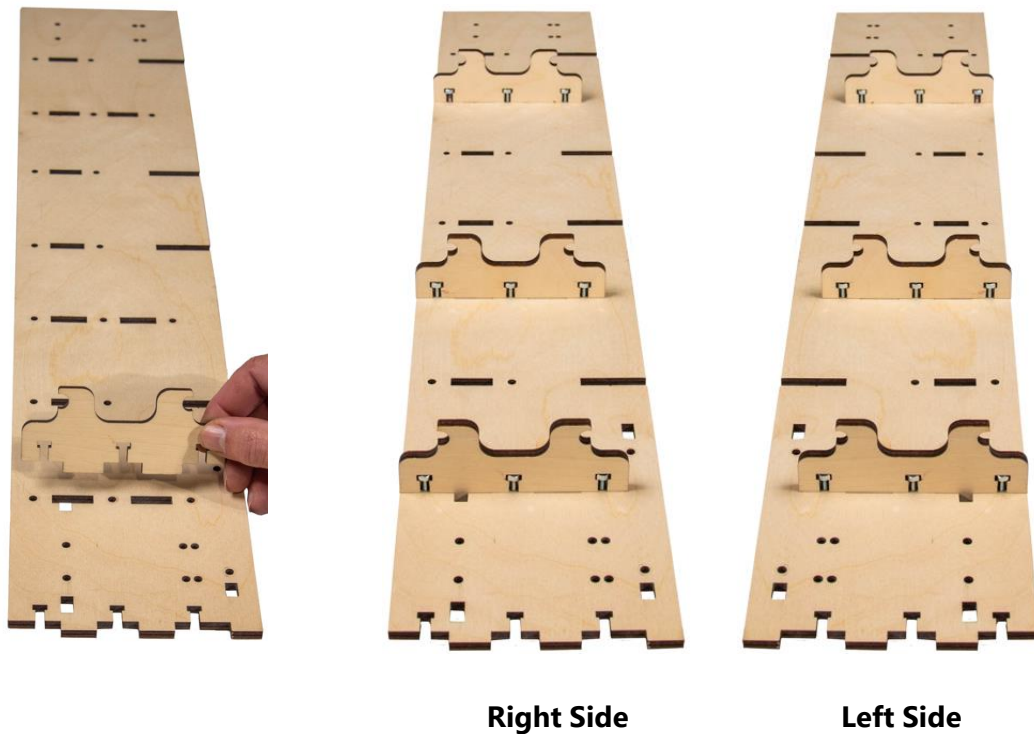

Step 2

Align the tabs of two Frame Corner Supports (previously removed) into the lower slots of the Frame Side Assembly and secure with two M4 x 16 Machine Screws and Nuts as shown. Repeat to complete the second Frame Side Assembly.

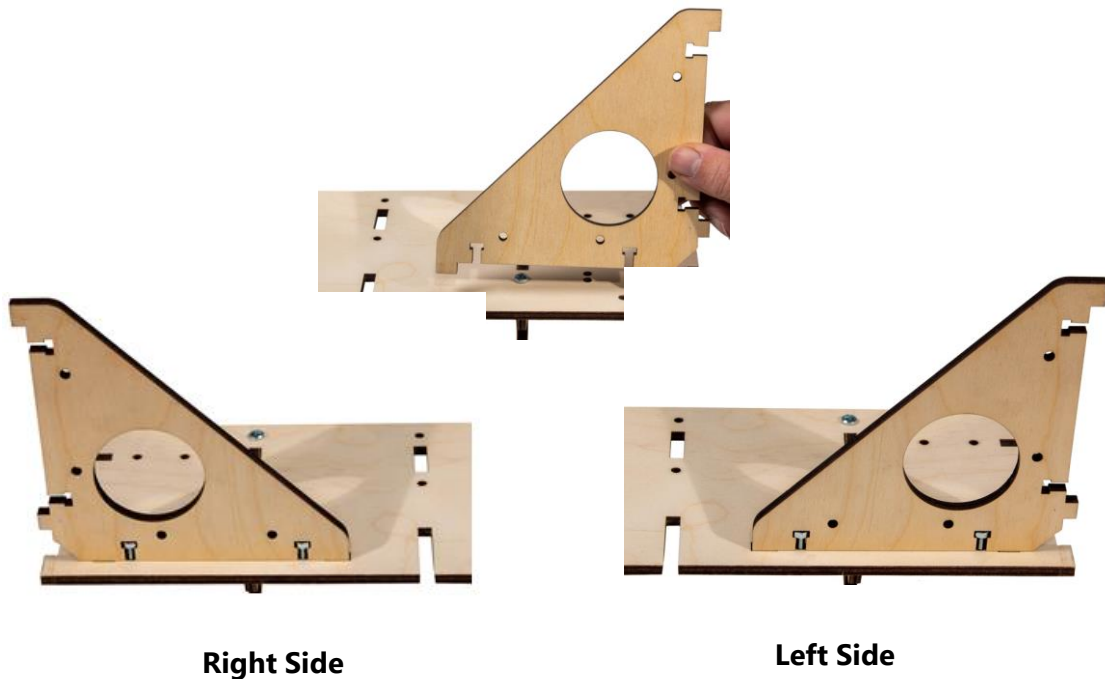

Step 3

Align the tabs of the four Frame Corner Braces (X2) into upper slots of the Side Assembly on the outside and secure with two M4 x 16 Machine Screws and Nuts as shown. Repeat on the remaining Frame Side Assembly.

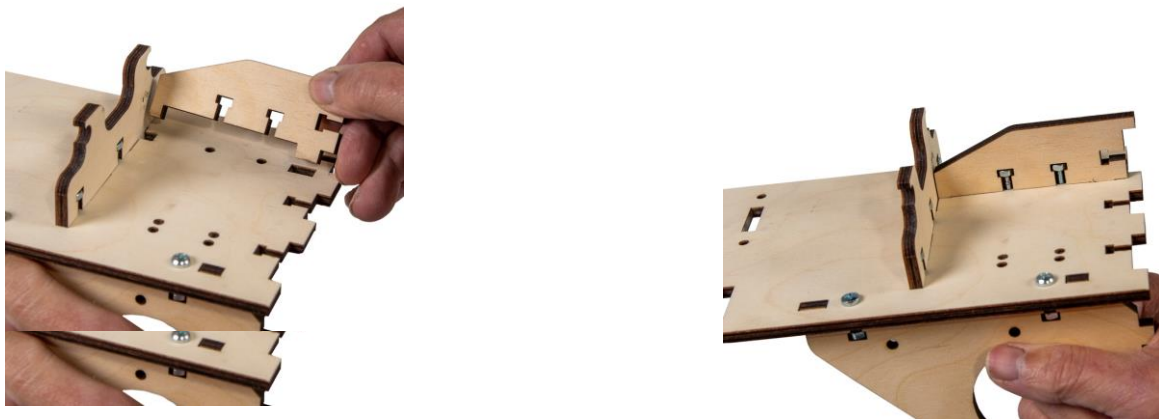



Completed Front Side Panel Assembly

Step 4 Align the slots in one of the Frame Side Assemblies with the tabs in the Frame Mid Support(X4) as shown and secure with two M4 x 16 Screws and Nuts.

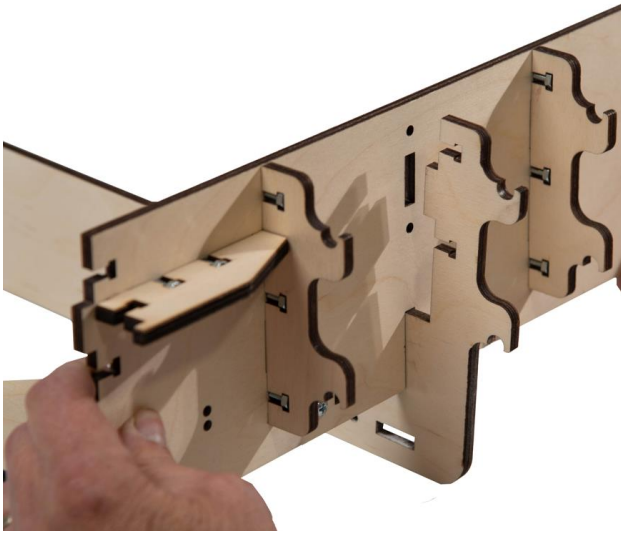

Outside View

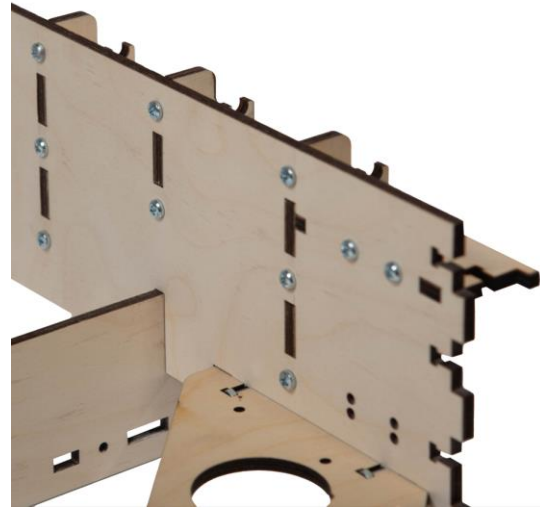

Inside View

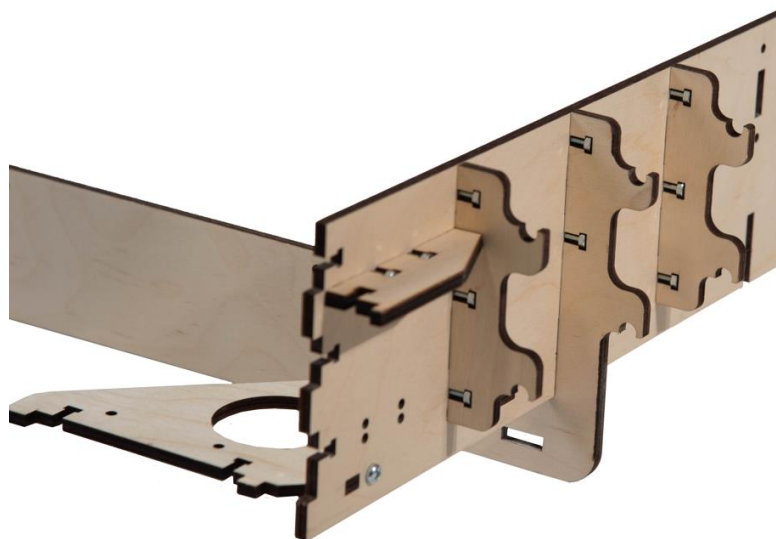

Step 5 Repeat the process until three Frame Mid Supports have been installed and secured on the right side.

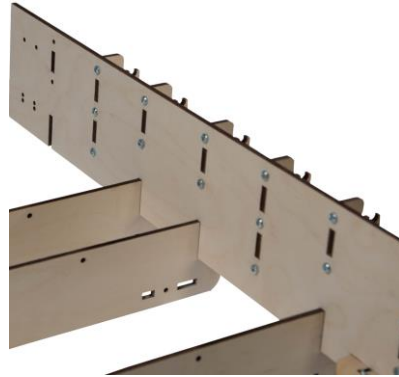

Step 6 Repeat this procedure to install the remaining Side Support Assembly.

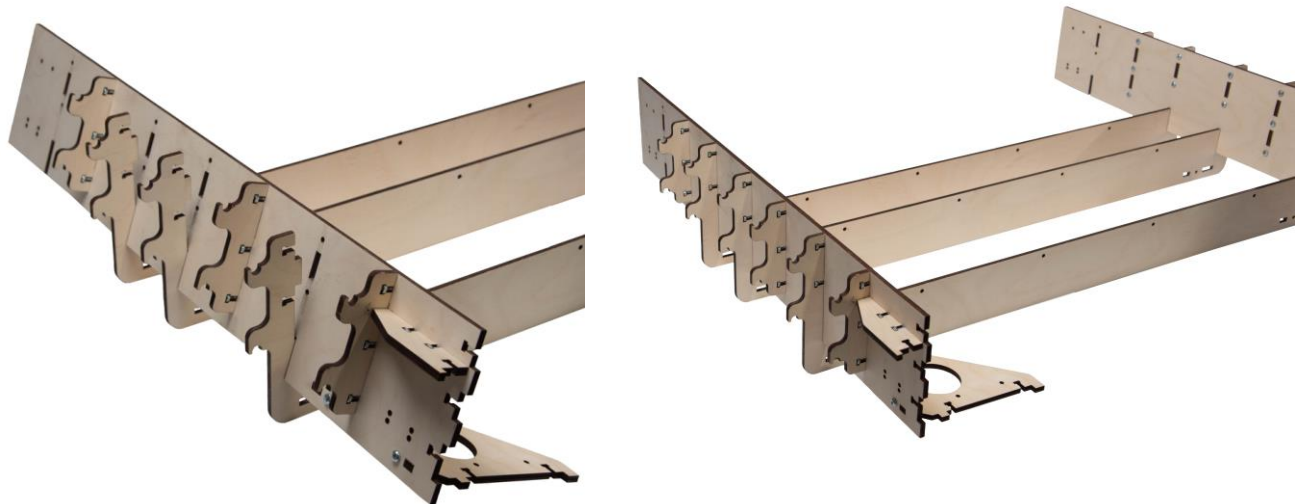

Step 7

Align the slots in the X6 Frame End Support with the tabs in the X Frame Assembly and secure each side with six M4 x 16 Screws and Nuts.

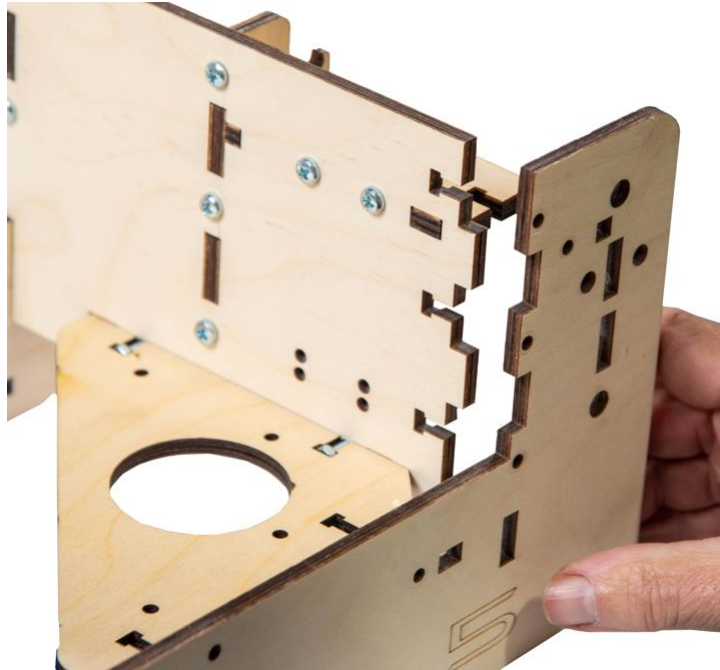

Completed Front Frame Assembly



The two Frame Side Support Rear panels have a square access hole and four ½” (12mm) holes. The four holes must be oriented on the bottom of the Assembly. They provide access for belt routing and bearing adjustment needed in later steps.

Step 1 To build the Rear Assembly of the X Frame:

Align the tabs of the Rail Supports (X1) into the slots in the Frame Side Rear Support (X5). Secure with three M4 x 16 Machine Screws and Nuts for each Rail support as shown

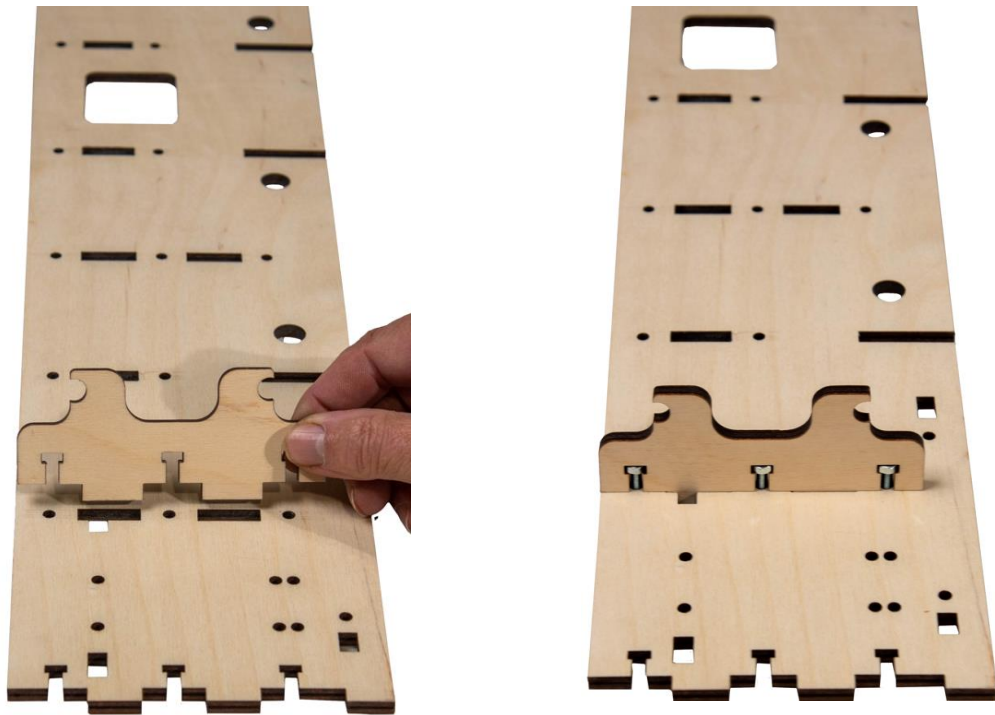

Step 2

Align the tabs of the remaining four Rail Supports (X1) into the slots in the Frame Side Support Rear(X5). Secure with three M4 x 16 Machine Screws and Nuts for each Rail Support as shown. Repeat to complete both Rear Side Support Assemblies.



Left Side



Right Side

Step 3

Align the tabs of the two Frame Corner Supports (X8) into the lower slots of the Side Assembly and secure with two M4 x 16 Machine Screws and Nuts for each side as shown.

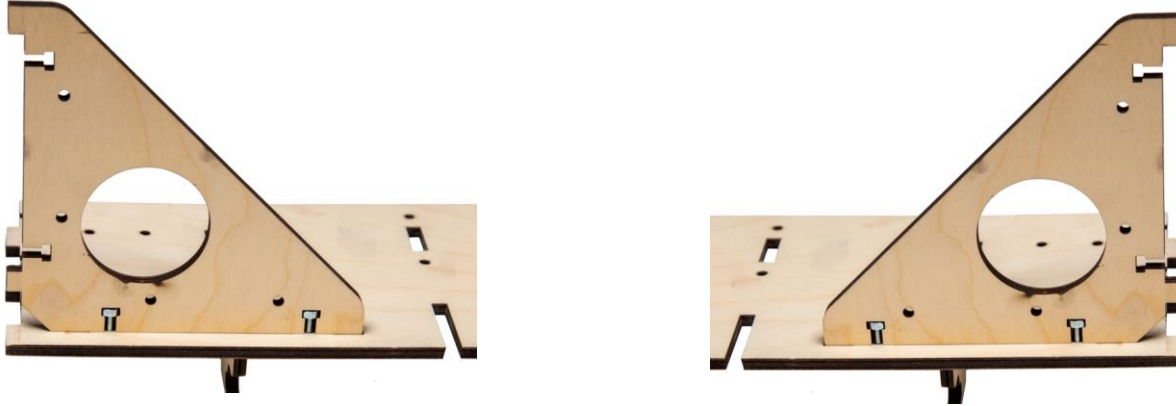

Step 4

Align the tabs of the two Frame Corner Braces (X2) into the upper slots of the Side Assembly and secure with two M4 x 16 Machine Screws and Nuts for each side as shown.

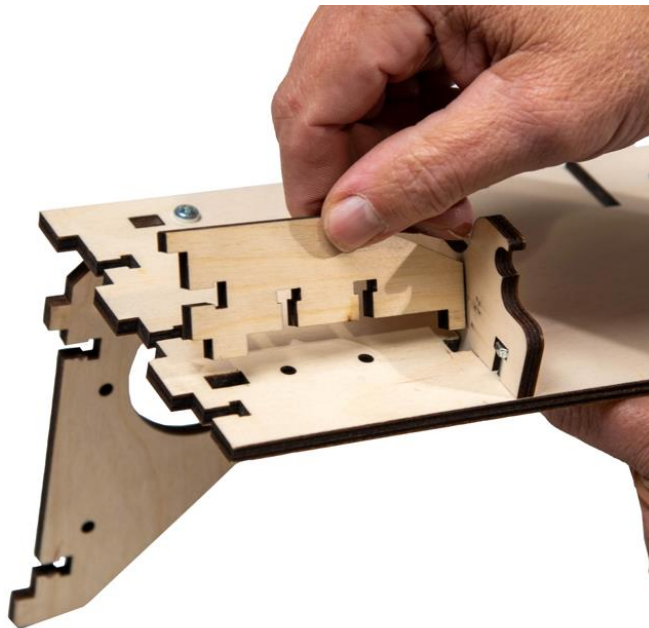



Completed Rear Side Panels

Step 5

Align the slots in the Right Side Assembly with the tabs in the in the Frame Mid Support (X4) as shown and secure with two M4 x 16 Screws and Nuts.

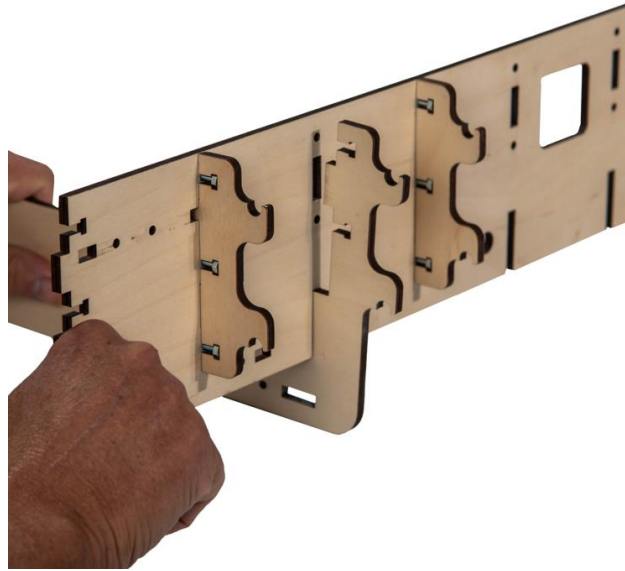

Step 6

Align the slots of the right Side Assembly with the tabs of the remaining three Frame Mid Supports as shown and secure with two M4 x 16 Screws and Nuts for each.

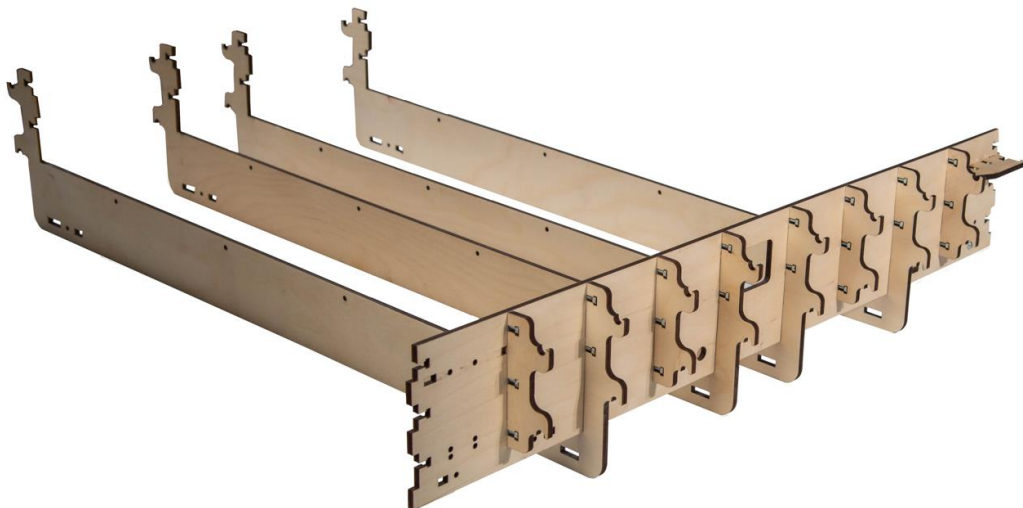

Step 6

Align the slots of the left Side Assembly with the tabs of the four Frame Mid Supports as shown and secure with two M4 x 16 Screws and Nuts for each.

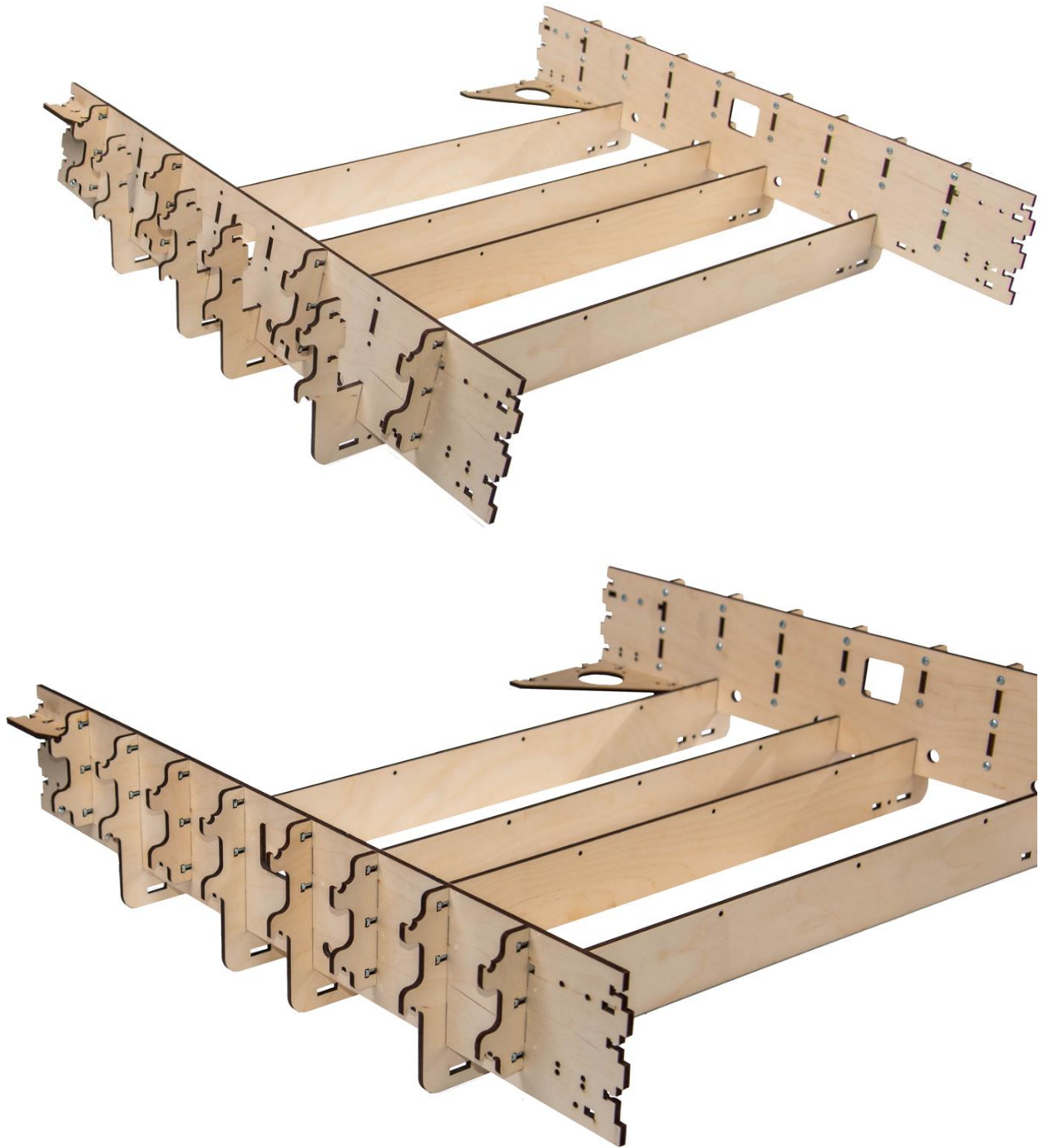

Step 7

Align the slots in the Frame End Support (X6) with the tabs in the Front X Frame Assembly and secure with six M4 x 16 Screws and Nuts.

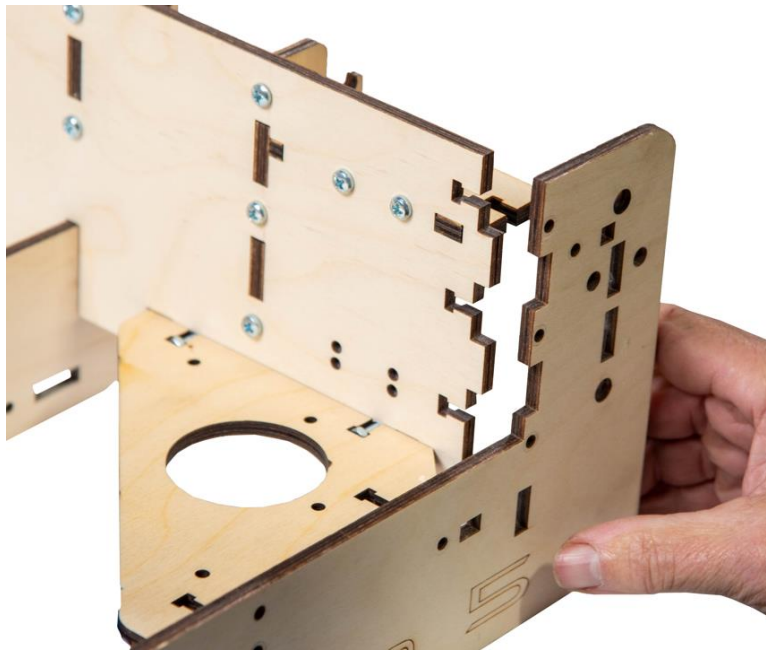

Completed Rear Frame Assembly

Step 8

Using the Extension Frame Mid Support (EX4), align the tabs of the Wire Harness Support (X7) with the slots and secure with two M4 x 16 Machine Screws and Nuts for each end as shown. Align and mount the Frame Mid Support (X4) to the Mid Frame Assembly.

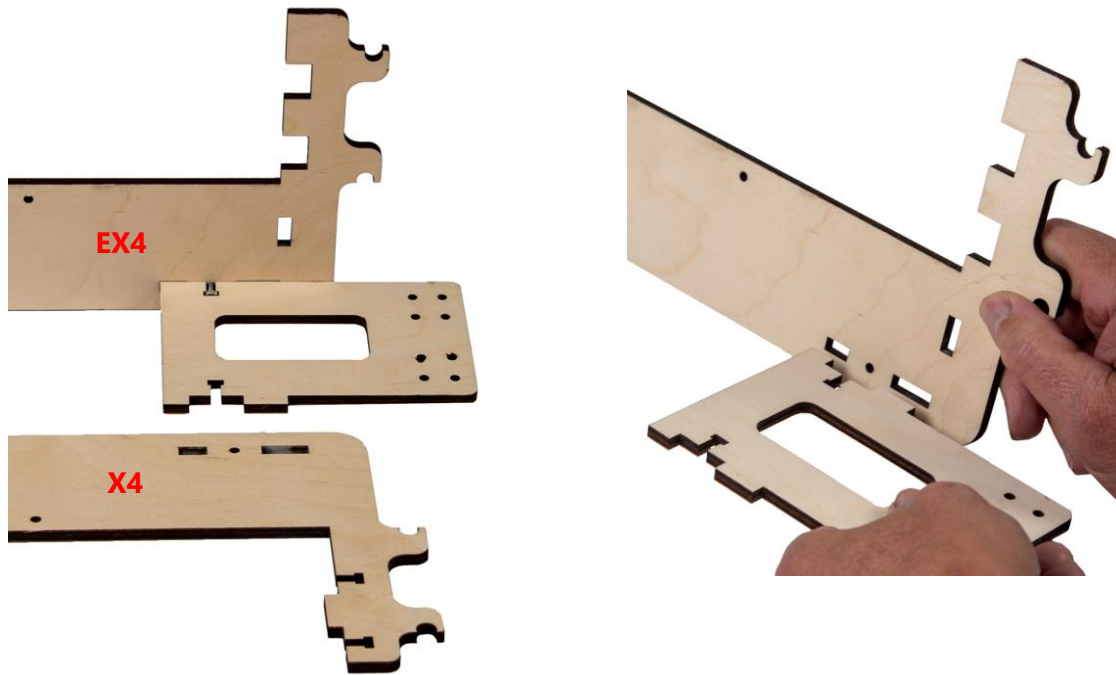

Repeat for the remaining Wire Harness Support (X7)



Completed Mid Frame Assembly

Step 9 Align the tabs of the Mid Frame Assembly into the slots of the Coupling Plate(EX12) (one for each Side of the Mid Frame Assembly) and press them together as shown.

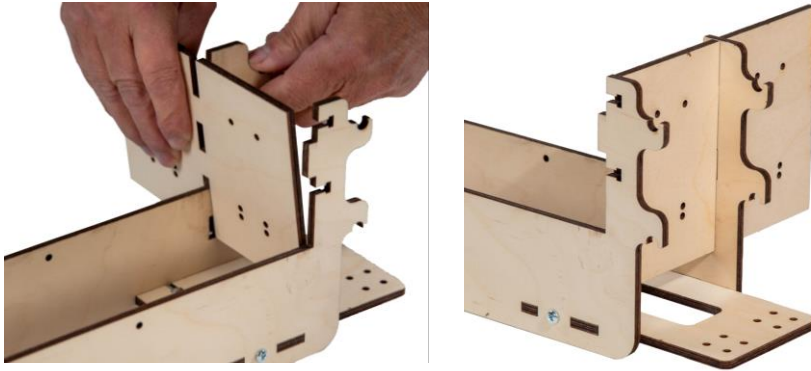

Step 10 Align the mounting holes of the Coupling Plates(EX12) with the holes in the Front X Frame Assembly. The ends of the Front X Frame Assembly will fit between the Coupling Plates.

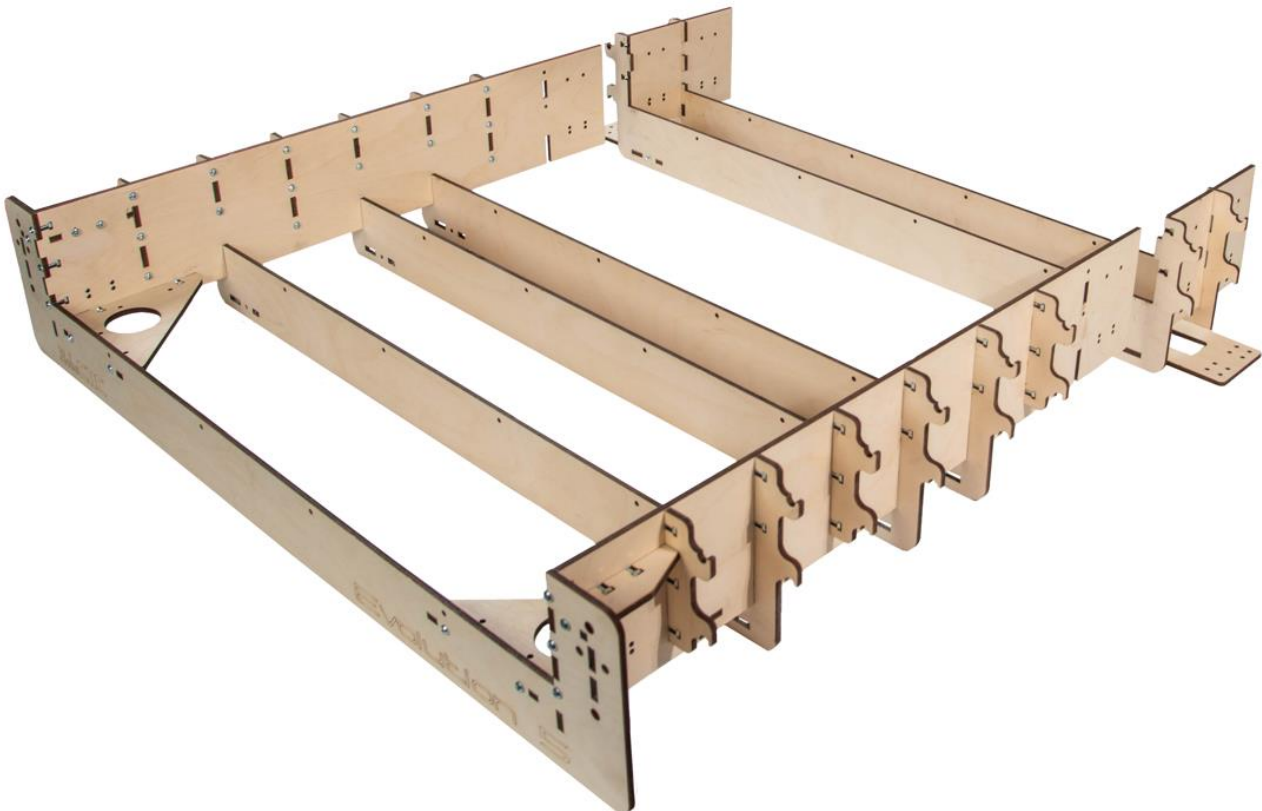

Step 11 Insert the tabs of the Frame Mid Support (X4) into the slots of the Front X Frame Assembly and secure with four M4 x 16 Machine Screws and Locking Nuts for each side as shown.

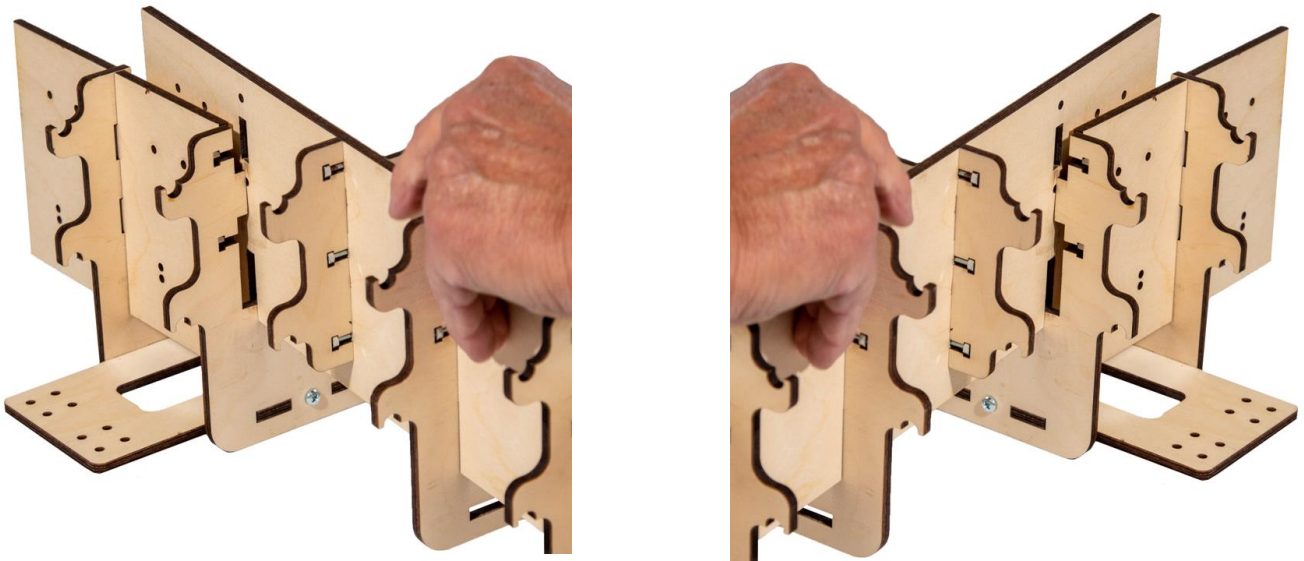

Step 12 Align the unused mounting holes of the Coupling Plate with the holes in the Rear X Frame Assembly.

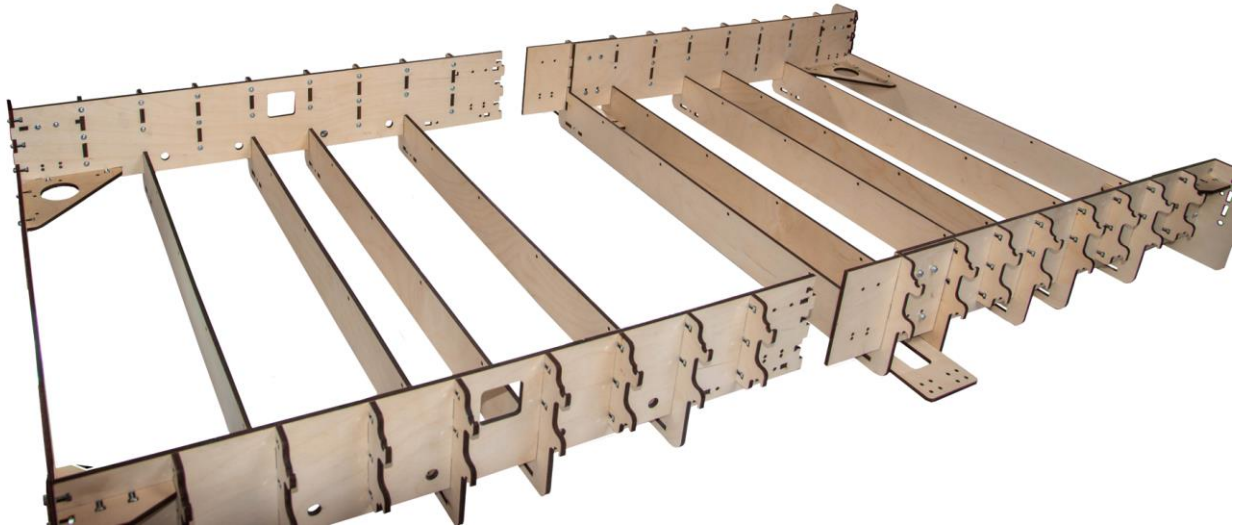

The ends of the Rear X Frame Assembly will fit between the Coupling Plates. Secure each side with four M4 X 16 Screws and Lock Nuts.







IMPORTANT NOTE: Before tightening the Lock Nuts, hold a straight edge across the top each side. Make sure the top edges of the entire X Frame Assembly are flat when tightening.







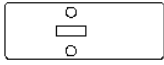

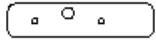
Completed X Frame Assembly

Final Assembly

Wood Components (Included with Kit)

Part #	Description	Qty	Photo
X9	Belt Retainer Short	2	
X10	Belt Retainer Long	2	
X3	Rail Stop	4	
X11	Belt Adjusting Plate	2	
G6	Rail Stop	2	

Required Hardware

Part #	Description	Qty	Photo
OO	Heat Shrink Tubing	1	
CB15	Pin Connector	1	
H56	GT2 Belt	3	
H82	Stress Proof Steel X Rail	4	
H53	Stress Proof Steel Y Rail	2	
H39	M6 x 30 Machine Screw	4	
H60	M6 Nut	8	

H38	M4 x 30 Machine Screw	5	
H15	M4 Nut	4	
R2	Makita Router	1	

Illustrated Step by Step Instructions

Step 1 Carefully position the Gantry Assembly on the X Frame Assembly as shown.



Step 2

Carefully insert the upper Stress Proof Steel X Rail into the X Frame Assembly through each of the upper Rail Supports and beneath each of the Upper Bearings of the Gantry Side Assembly as shown. Repeat this for other side.





WARNING Prior to installing the Lower Rails, adjust the Eccentric Spacers so that the lower Bearing Assemblies are at their lowest position.

Step 3 Observe the SG20U Bearing while turning the hex head of the Eccentric Adjustment Spacer until you see that the Bearing is set to its lowest position. Do this for all four of the lower Bearings. Using a Sharpie, mark the hex point closest to the outermost adjustment mark as shown.



Step 4

Carefully insert the lower Stress Proof Steel X Rail into the X Frame Assembly through each of the Rail Supports and above each of the Lower Bearings of the Gantry Side Assembly as shown. Repeat for the other side.

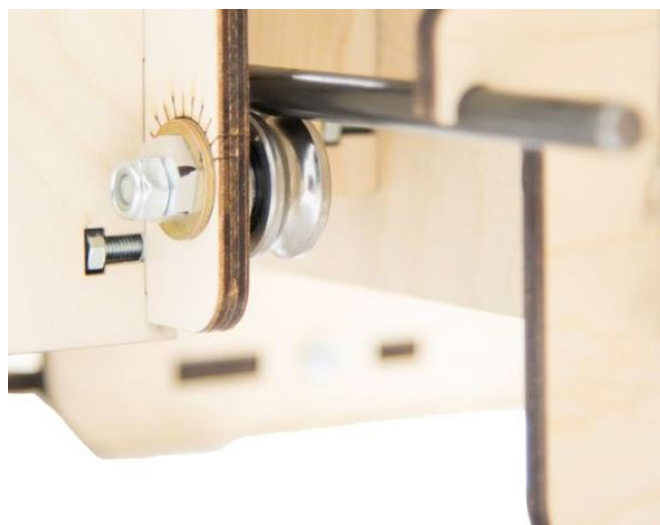
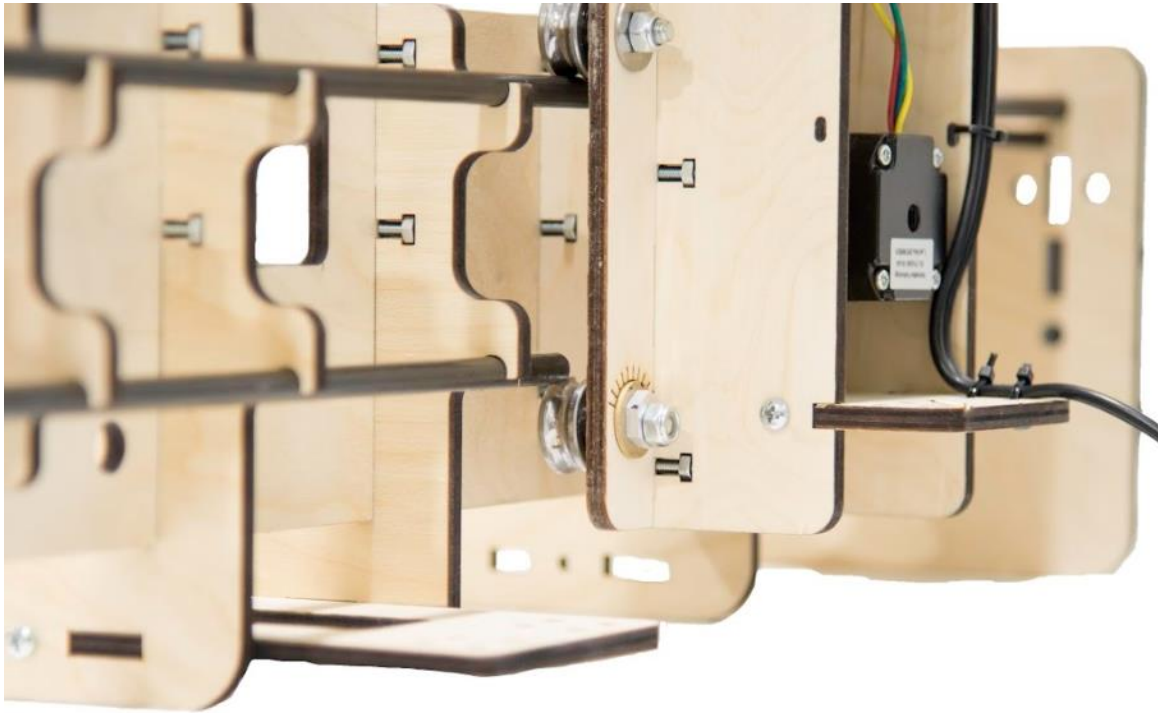

Step 5 Adjusting the Eccentric Spacers

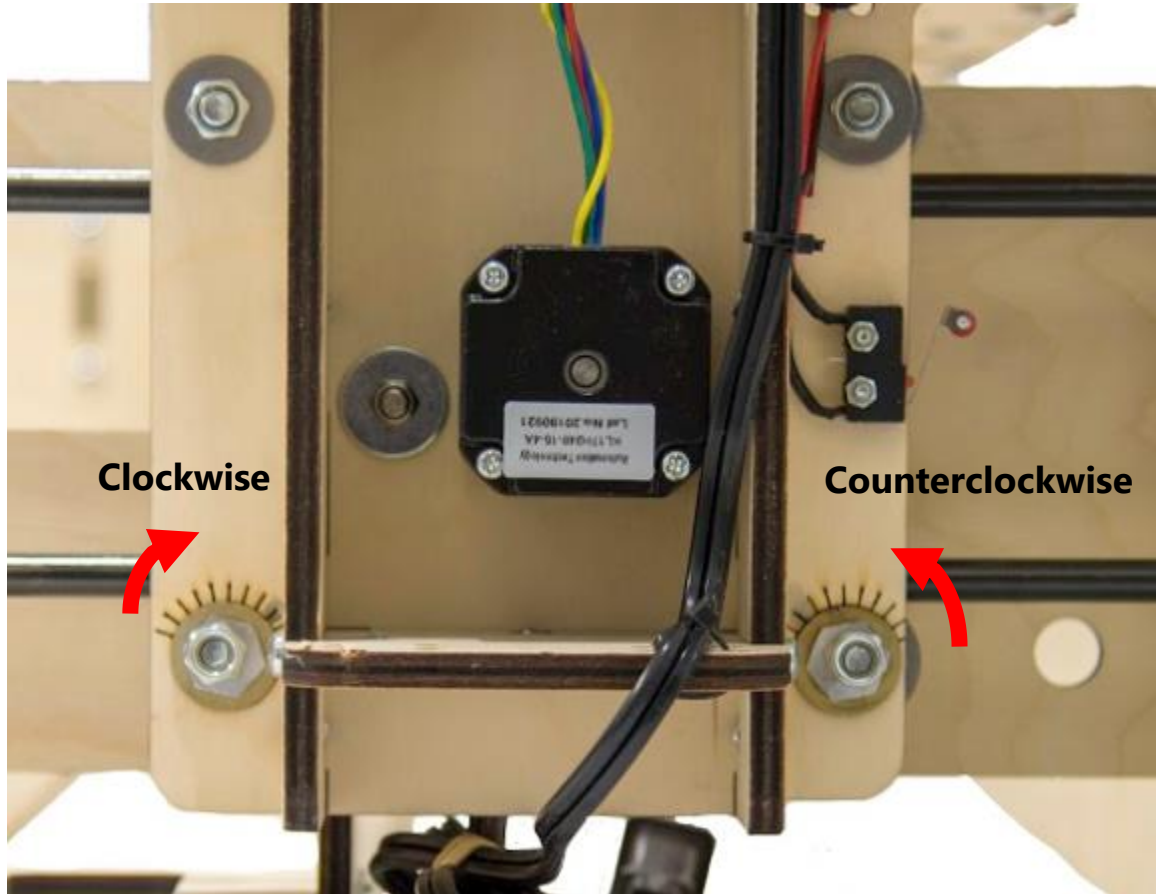

NOTE: To raise the SG20U Bearing against the Rail on the Left Side, rotate the Eccentric Adjustment Spacer clockwise. To raise the Bearing on the Right Side, rotate the Eccentric Adjustment Spacer counterclockwise.

- 5a** Adjust the right-side Eccentric Spacer upward with a 13mm wrench until it fits snugly against the Rail. Using your fingers, try to turn the Bearing. The Bearing should only move if the Gantry moves.

Note the position of the mark that was made on the right-side Eccentric Adjustment Spacer. Count the number of adjustment marks between the lowest position and the final tightened positioned. Make a corresponding adjustment mark on the left side.

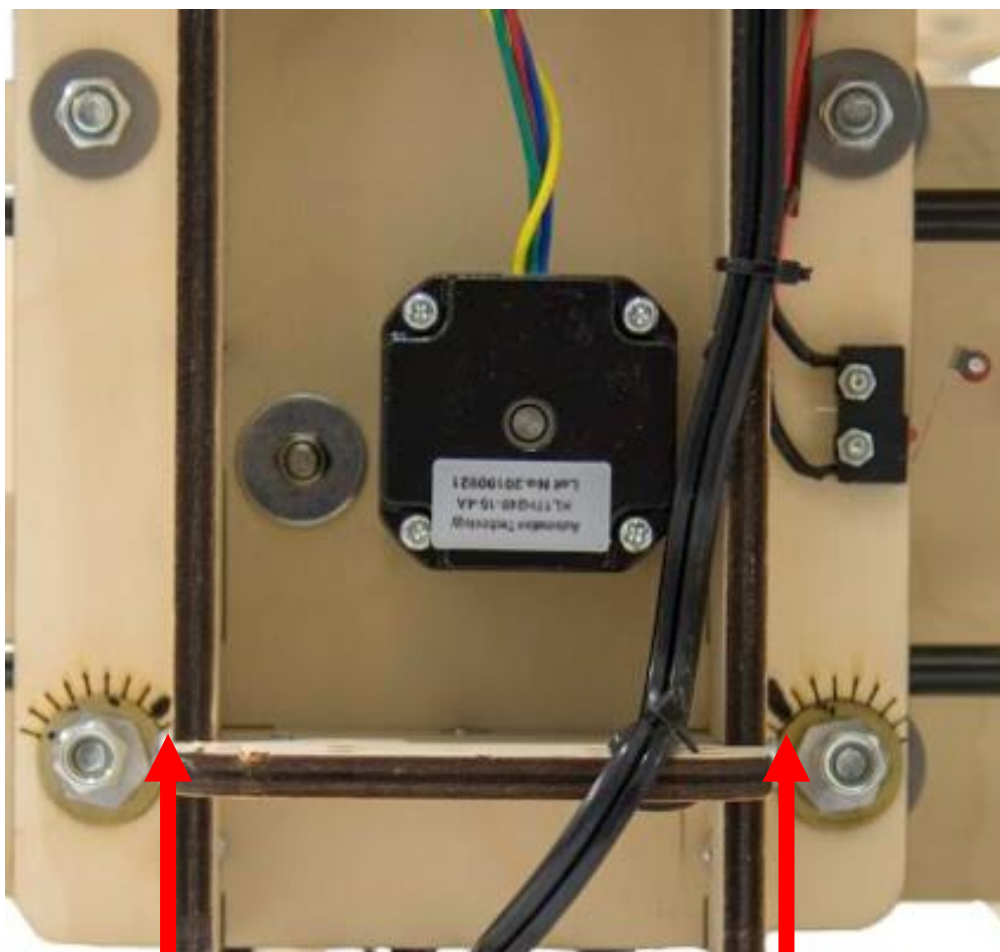

Adjustment Marks

Using a 13mm wrench, raise the left lower Bearing to the corresponding mark. Using your fingers try to turn the left lower Bearing. The Bearing should only move if the Gantry moves. Once the Bearings are snug against the Rail, tighten the Locknut with a 10mm wrench and Phillips Head screwdriver as shown.



NOTE: There are access holes located at the bottom of the Sides of the X Frame to help you tighten the Bearings.

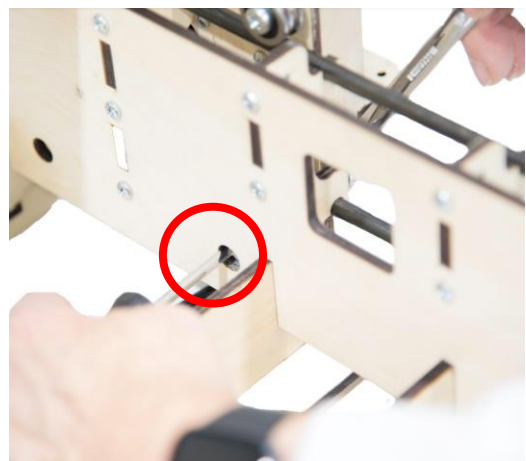

Step 6 Installing the X GT2 Belts. (Photos of right-side installation).



WARNING Belt routing is important. Ensure proper placement as illustrated in X1 Side View (page 129) and X2 Side View (page 130)

- 6a** Cut two of the GT2 Belts to a length of **60 7/8** inches.
- 6b** Insert one end of the Belt into the Short Belt Retainer (X9).



- 6c** Next, thread the free end of the GT2 Belt through the Rail Stop (X3). NOTE: In the photo, the Rail Stop has been rotated so that the slot is oriented toward the bottom of the Rail Stop.



6d Insert the Belt Retainer and Belt into and through the Rail Stop. Then insert the Assembly into the bottom slot at the back of the X Frame Assembly.

NOTE: Using a Zip Tie, snug the Belt in the Retainer. Make sure the square lock of the Zip Tie is located on the top of the Belt Retainer.

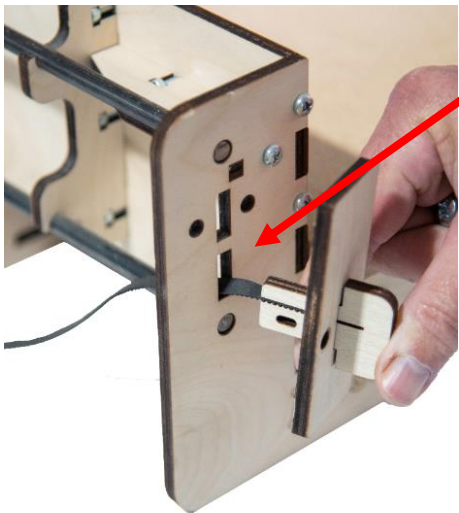
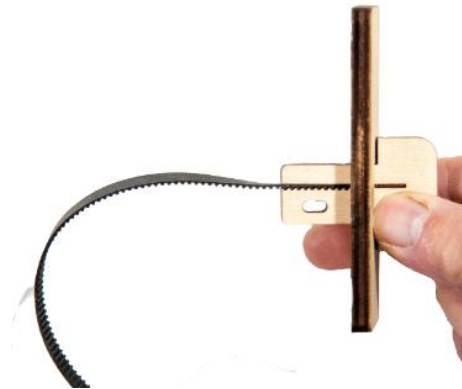

Be sure to insert in the lower slot at the rear of the machine.

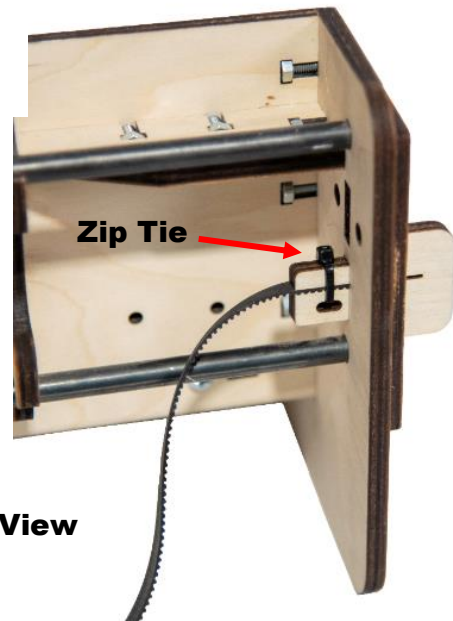

Right Side Rear View

6e Routing the free end of the Belt through the Gantry.



Note: Slide the Gantry Assembly in front of the square access hole in the X Frame. This opening provides the access you need to loop the Belt around the Idler and Flange Bearings. We suggest that you watch the short video demonstrating how to correctly route and install the Belts around the Flange and Idler Bearings. <https://youtu.be/SAz9UjGeOa0>





The following photos illustrate the proper path for routing the Belt. The photos were taken before the Gantry was installed on the X Frame for Illustration purposes only! The Gantry Assembly must be installed on the X Frame Assembly before attempting to install the Belts.

- 6f** Route the Belt with teeth facing down beneath, over and then around the Idler Pulley. Note the teeth on the belt are facing outboard.



- 6g** Loop the Belt over the Belt Pulley so that the Belt teeth engage the teeth of Pulley.

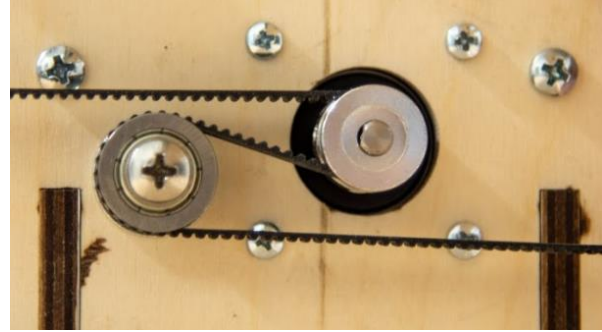

**Finished Belt Routing
viewed through the
access port.**

- 6h** Repeat for the other X Belt.

Step 7 Securing the X1 and X2 Belts

7a Insert two M6 x 30 Machine Screws through the Belt Adjustment Plate (X11) and secure with a M6 Nut.



7b Add one M6 Nut to each Machine Screw as shown.

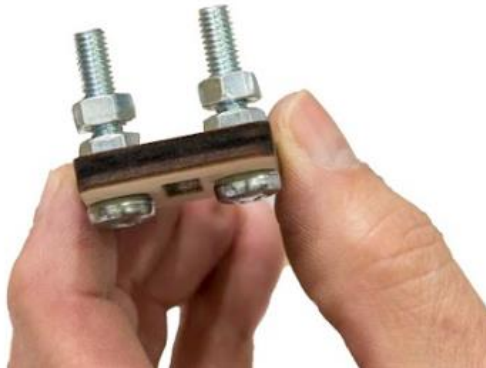

7c Insert the Long Belt Retainer (X10) through the Belt Adjusting Plate into the Rail Stop (X3) as shown.



- 7d** Insert the Belt Tightening Assembly into the upper slot of the X Assembly as shown.

At the front of the machine be sure to insert in the upper slot.

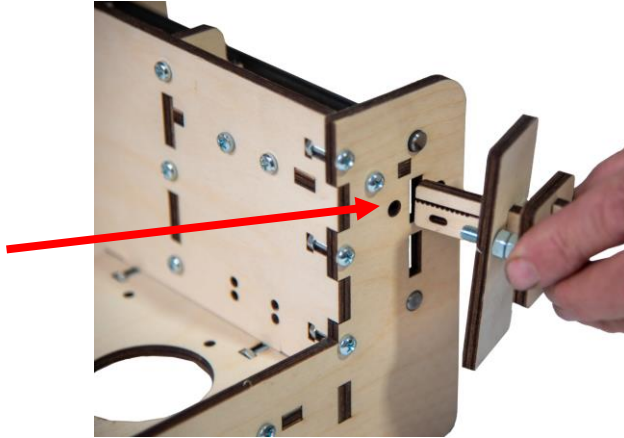

- 7e** Insert the end of the Belt into the Belt Retainer. Be sure to seat the Belt completely in the Retainer as shown and secure with a Zip Tie.

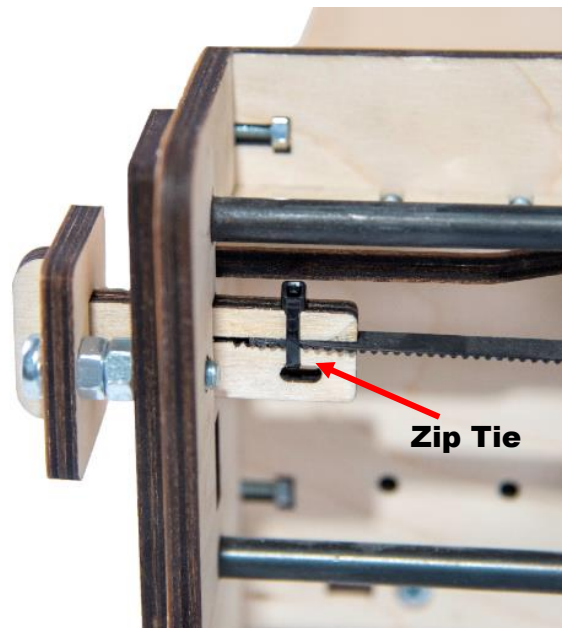

- 7f** Repeat the steps for the remaining X belt.

Step 8

Attaching the Y Carriage Assembly and Y Axis GT2 Belt

- 8a** Insert the upper Y Axis Stress Proof Steel Rail into the Gantry Side and carefully thread the Rail through the upper Rail Supports and into opposite Gantry Side as shown.

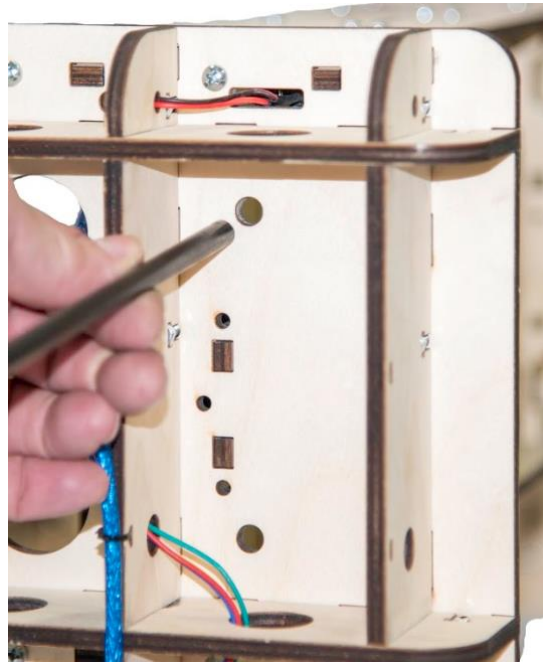

- 8b** Cut one of the GT2 Belts to a length of **56 1/2** inches.
- 8c** Lay the Y Carriage Assembly on the X Frame Assembly and insert the ends of the Y Axis Belt into the Belt Retainer making certain the Belt is not twisted.

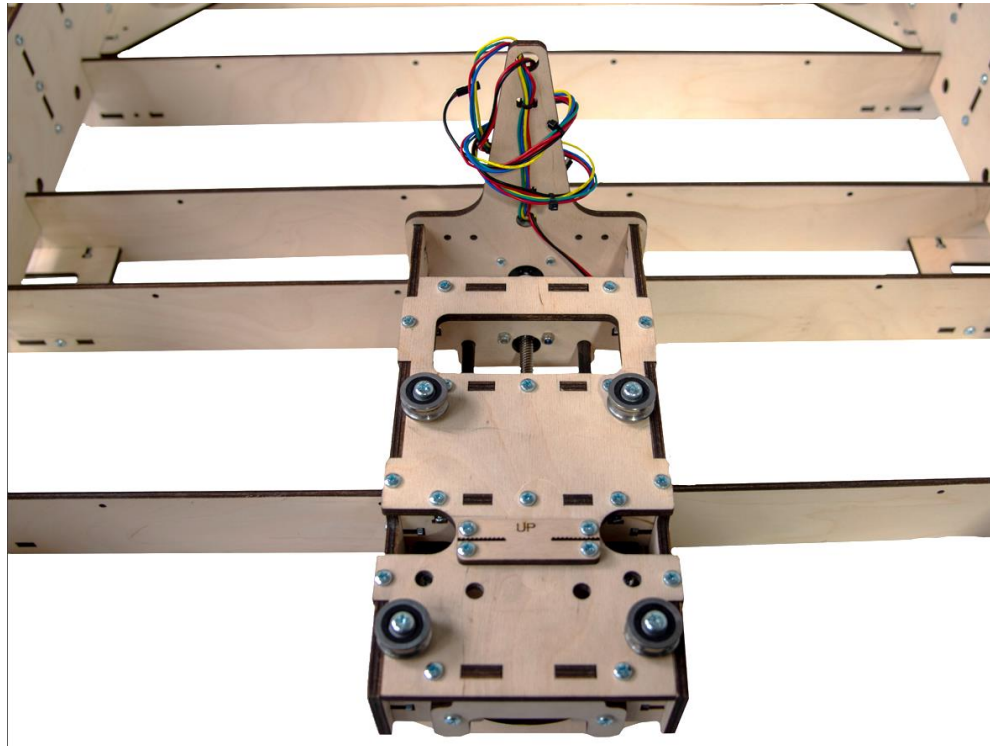

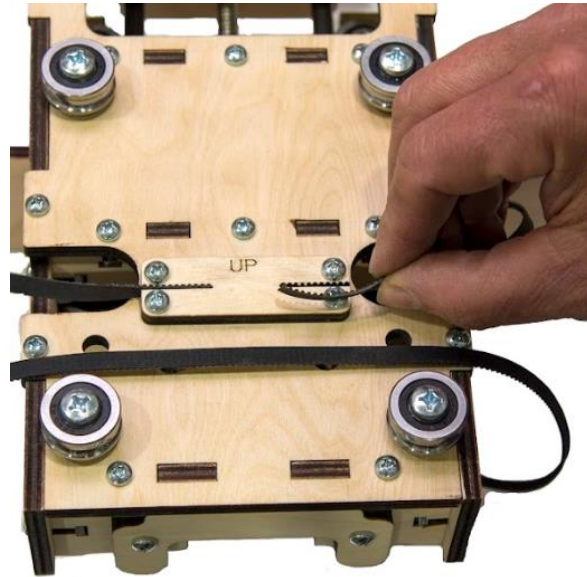
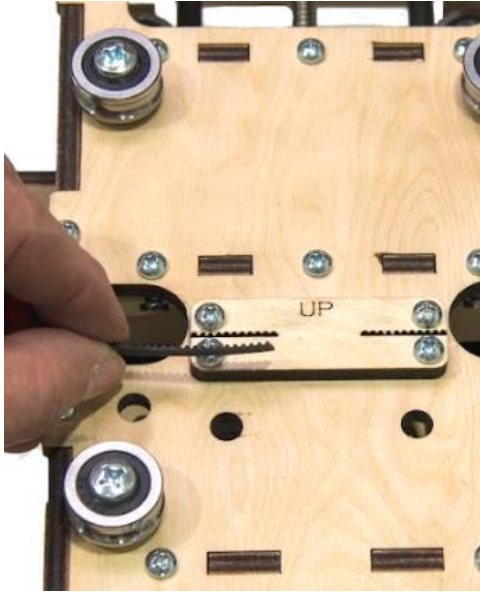

- 8d** Carefully loop the Belt around the Y Carriage Assembly, making sure the ends remain secure in the Y Belt Retainer. Then hang the upper Bearings of the Y Carriage Assembly onto the upper Y Rail as shown, being careful to keep the Belt between the upper and lower Bearings.

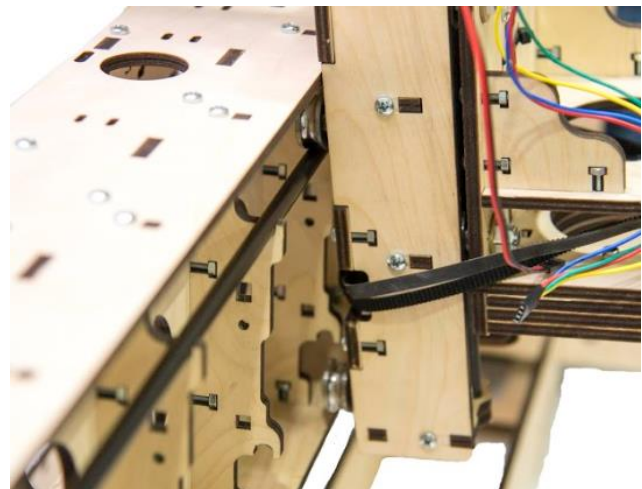
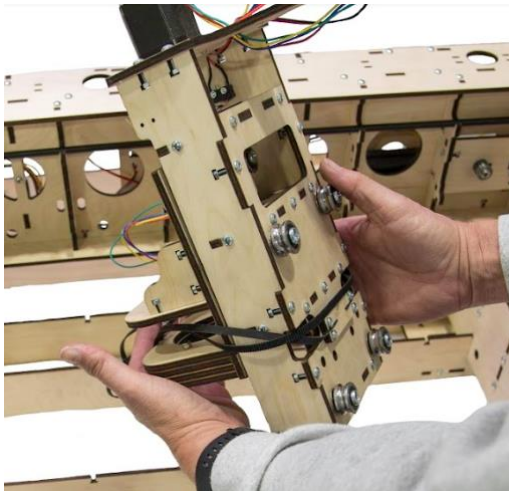

- 8e** With the Belt secure, insert the lower Y Rail through the Gantry Side, through the lower Rail Supports, over

the lower SG20U Bearings, and across into the opposite Gantry Side.



- 8f** Attach the Rail Stops to each end of the Gantry Side using two M4 x 30 Machine Screws and Nuts for each side as shown.

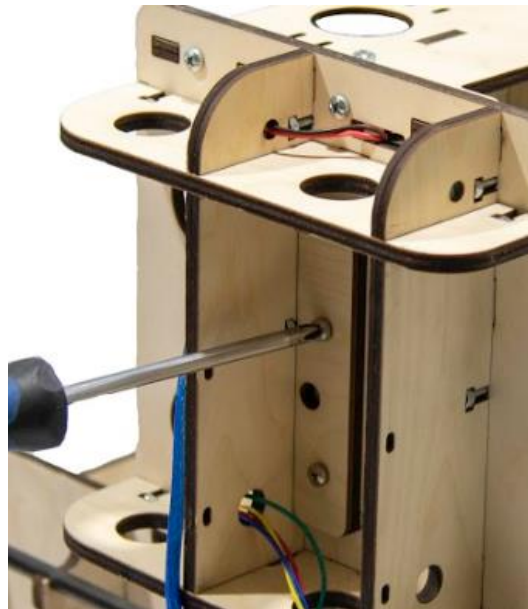

- 8g** Loop the Belt over the Idler Pulley as shown. Make sure the Belt is not twisted and that the Belt teeth are oriented as shown.



- 8h** Loop the other end of the Belt over the Belt Pulley as shown. Make sure the teeth in the Belt engage the teeth of the Pulley.





8i Adjust the Y Carriage Eccentric Spacers equally on both sides using the alignment marks to tighten Bearings against the Rail as shown.

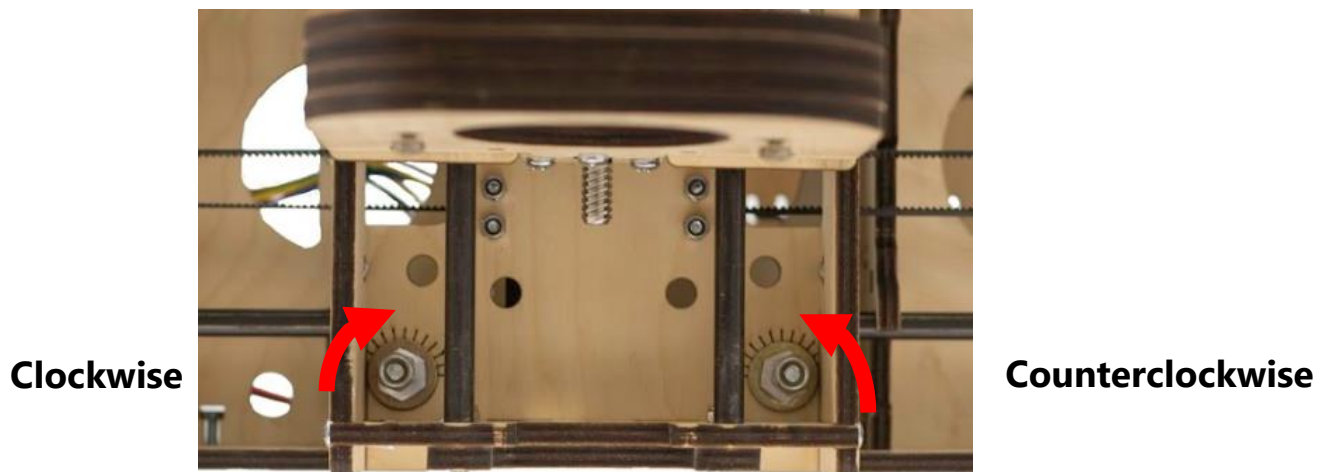

8j Align the access hole in the Gantry with the Bearing Screw. Using a 10mm socket and a Phillips Screwdriver tighten the Lock Nuts to secure the 4 Bearing positions.



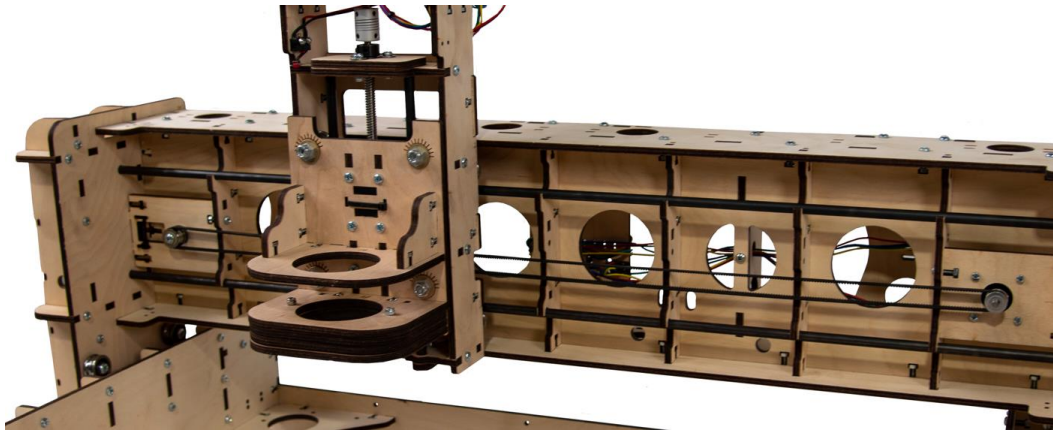

Completed Y Axis Belt Installation

Step 9 Wiring the Self Squaring Gantry.

- 9a** Separate the red and black Wire on the X2 Home Switch Wire as shown.

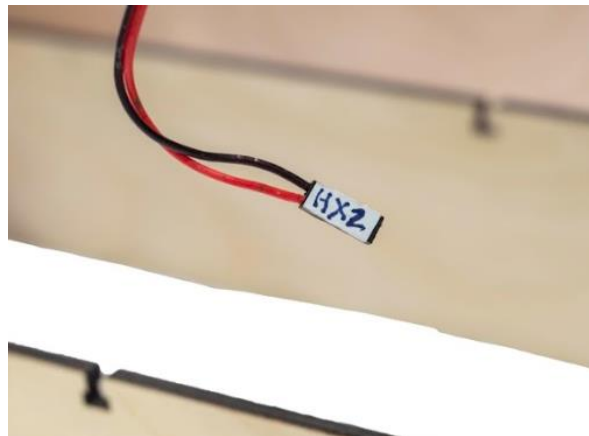

- 9b** Turn the pin connector over to view the locking mechanism that holds the wires in place.

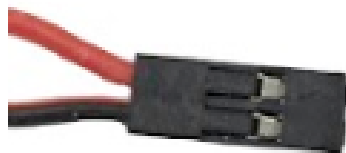

- 9c** Using the sharp point of a thin blade. Insert the blade beneath the wire lock and gently lift to remove the black wire.

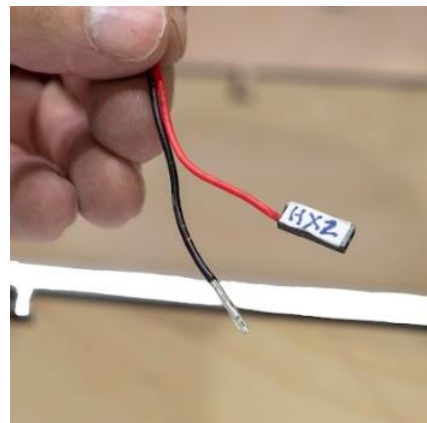
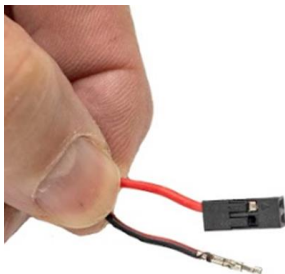
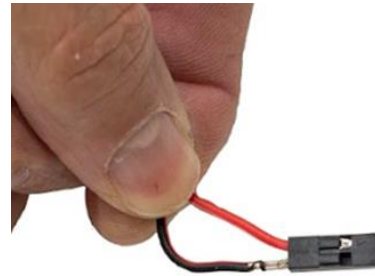

- 9d** Repeat these steps with the Z Home Switch.

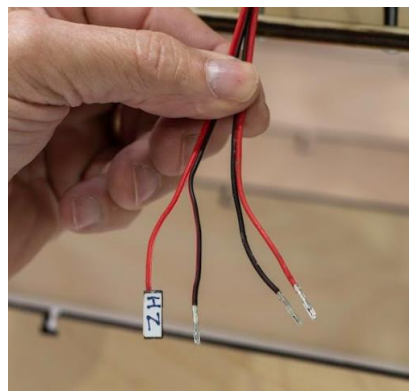

- 9e** Connect the black Z axis Home Switch Wire to the black X2 Home Switch Wire using the Pin Connector as shown.

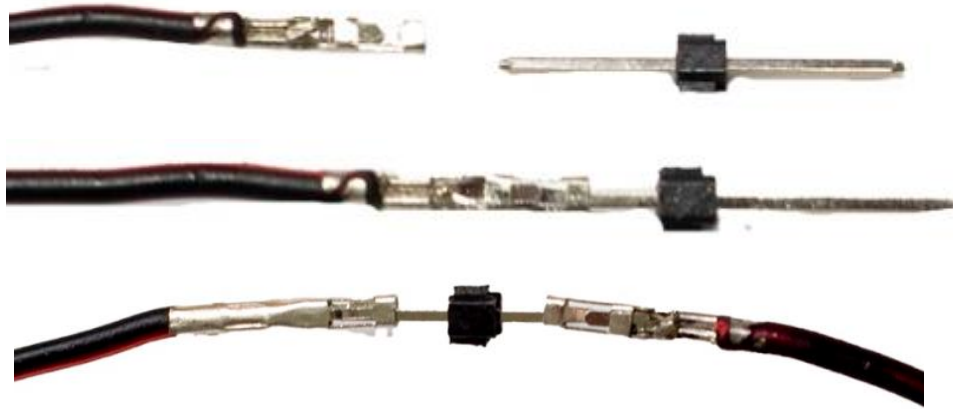

- 9f** Cover the splice with the heat shrink tubing. Using a lighter or heat gun, carefully heat the tubing so that it shrinks securely around the pin connector as shown. Insert the remaining wire into the black 2-pin connector.



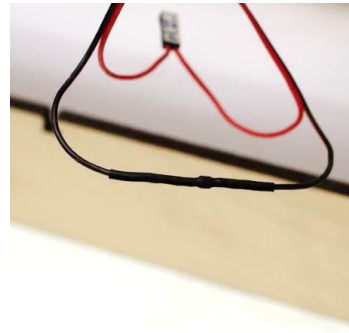
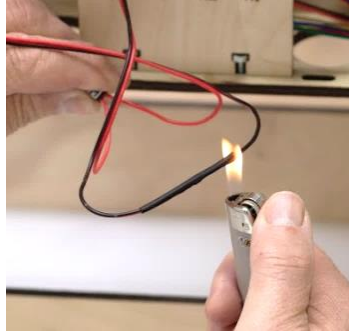

Below is a schematic of the wiring of the self-squaring gantry. Note the black line represents the splice connect the Z and X2 black wires. Both red wires are connected to the controller via a DuPont connector to the Z+ pin terminal.

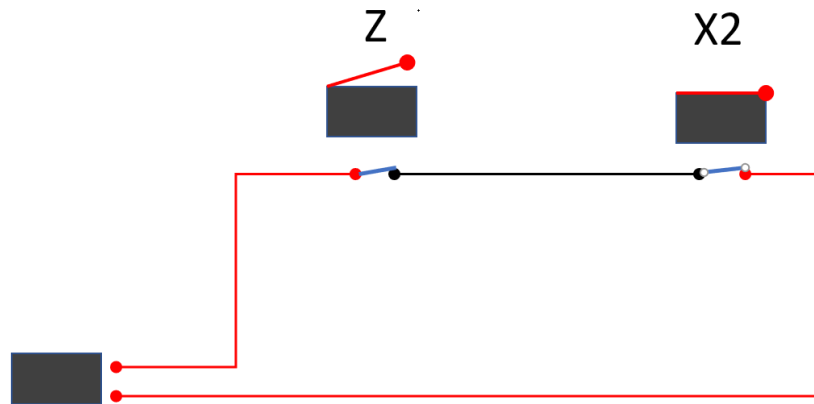

- 9g** Plug the connector to the Z+ pin terminal on the controller and secure the spliced wires with a Zip Tie.



- 9h** Plug the Z Stepper Motor connector to the Z Driver and secure with a Zip Tie as shown.

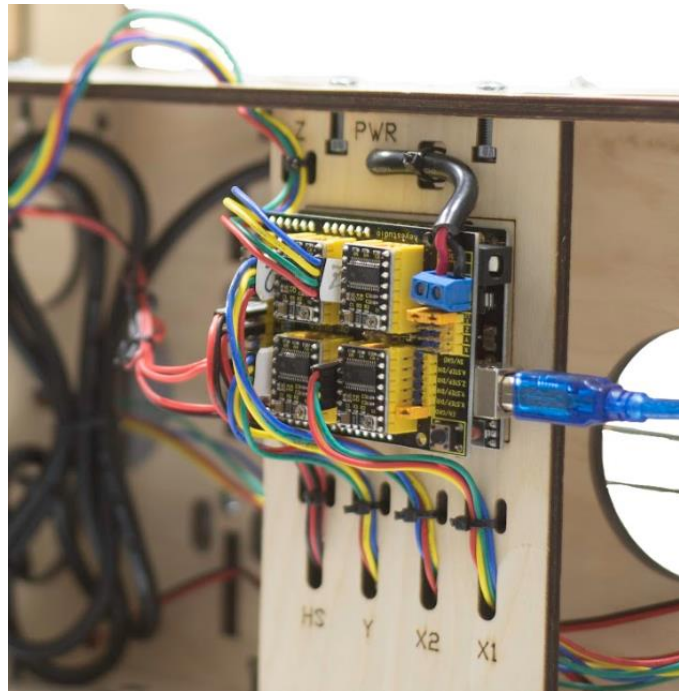

Step 10 Installing the Router

NOTE: The manual shows installing a Makita RT0701C Router.

- 10a** Insert the Router into the Holder and with downward pressure gently twist the Router body until it is fully seated in the Holder as shown.

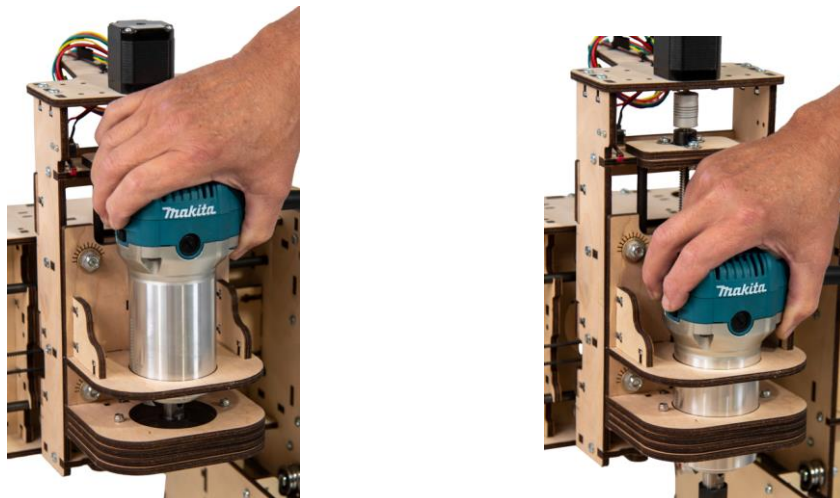

- 10b** Tighten the four Screws in the Router Z Mount. Align each Screw with one of the elongated access holes in the back of the Gantry.

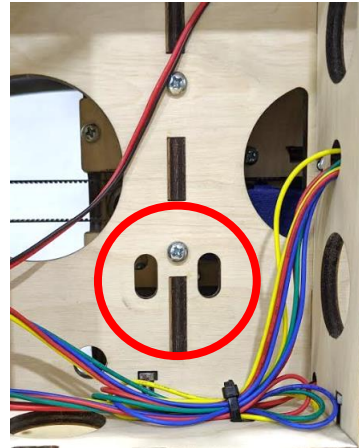

Note: To align the access hole with the Phillips head screws it will be necessary to raise or lower the Z Carriage. This can be done by manually rotating the Helical Coupler at the top of the Z Axis as shown.

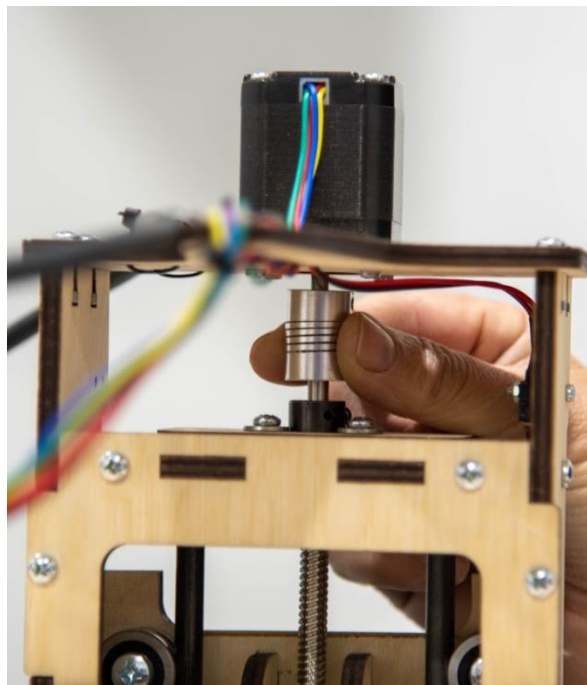

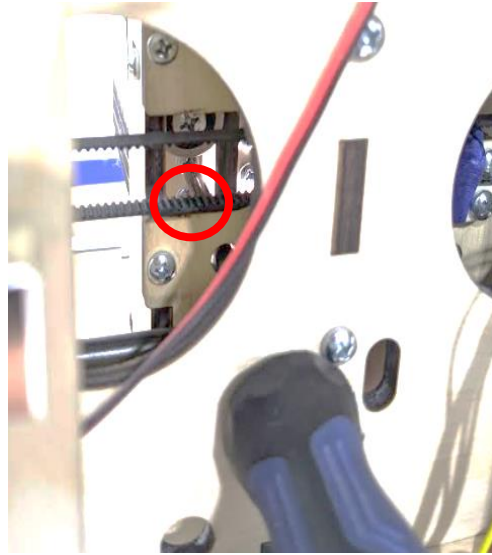

10c Tighten the 2 M4 X 30 Machine Screws and Lock Nuts to clamp the lower Router Mount.

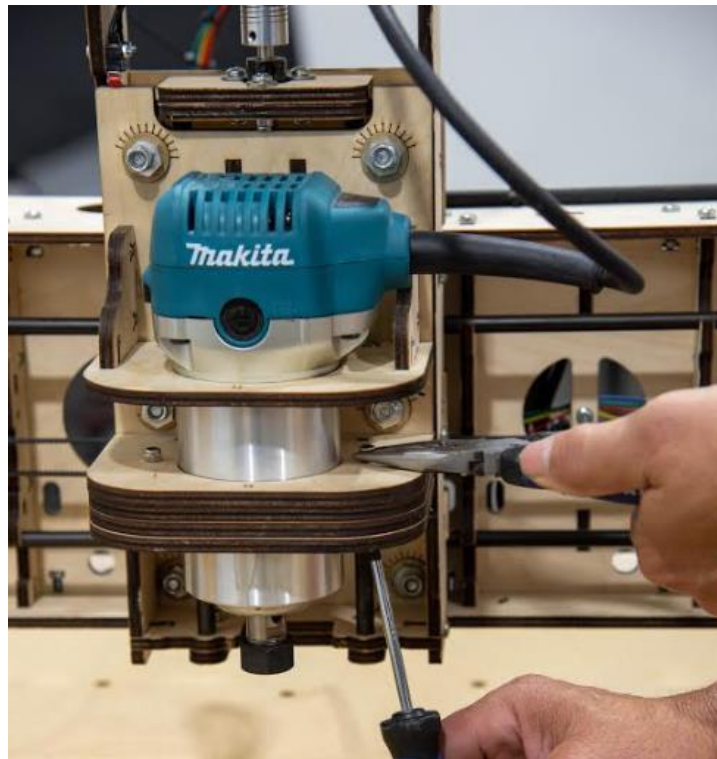

- 10d** To secure the Router Cord to the Router Carriage and Gantry, first lower the Router Carriage as low as possible. Use Zip Ties to secure the Router Power Cord to the top of the Router Carriage Assembly as shown. Be careful to route the Cord without putting stress on the stress relief as shown.

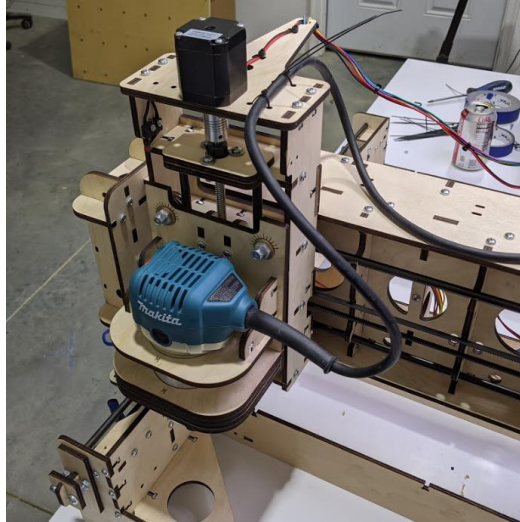

- 10e** Route the plug down and through the access hole on the left side of the Gantry Back Side as shown, then through the side access hole.

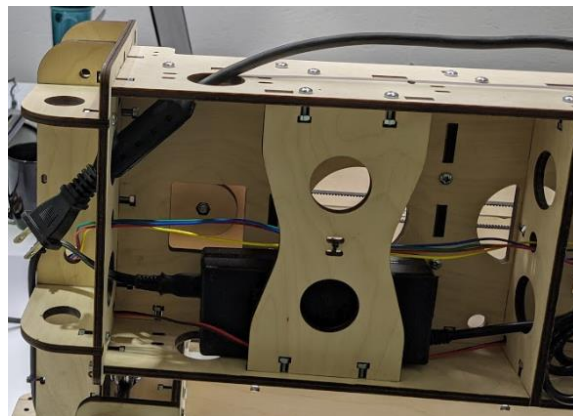

- 10f** Facing the back of the Gantry, slide the Router Carriage all the way to the right. Allow enough slack in the Cord so that the Router Carriage can travel from the right side of the Gantry to the left without binding as shown.

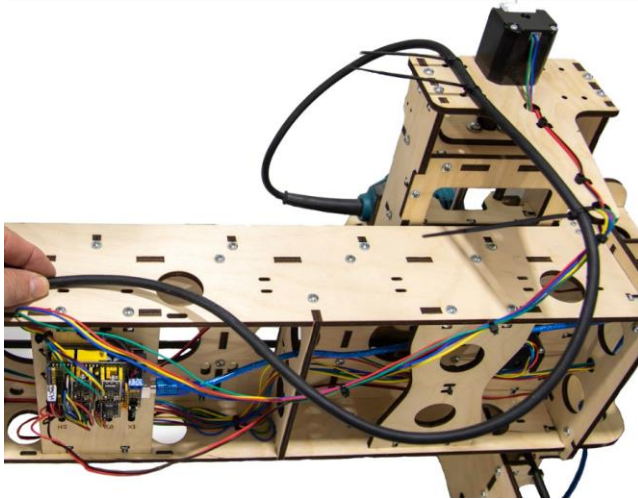

**Cord length
estimated from the
right side.**

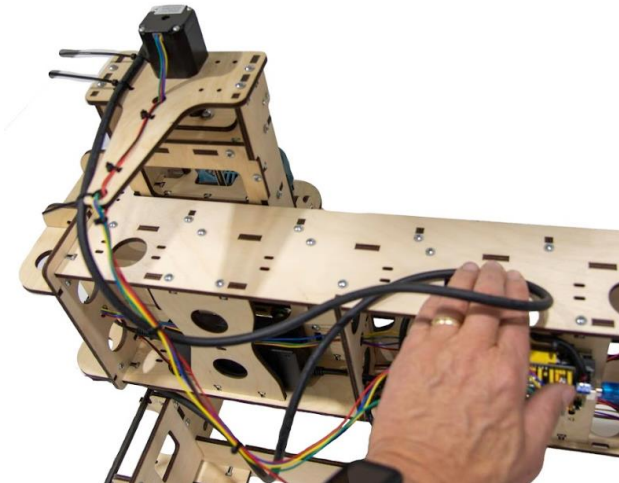

**Cord length
estimated from the
left side.**

- 10g** Final Wire Management. Zip Tie the Power Cord to the side of the Gantry as shown. Then tie them together and secure them to the Gantry Lower Side Brace as shown. In the same way tie the USB Cord to its Wire Harness Support as shown.

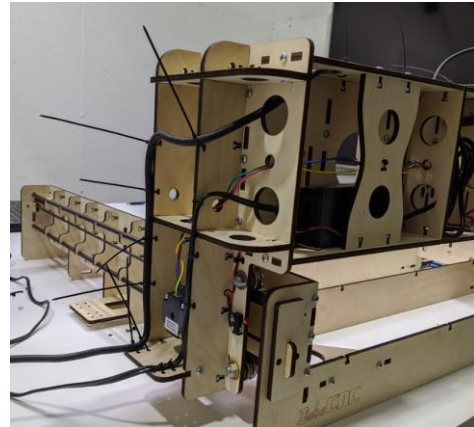
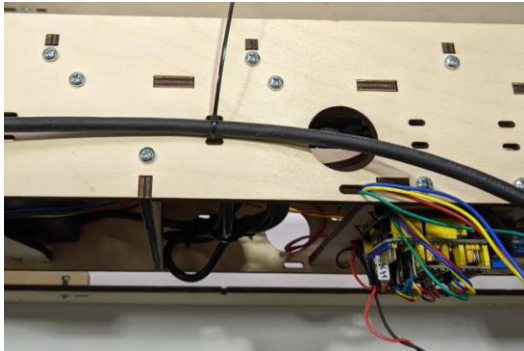

Power cord secured along the edge of the Gantry side.

- Step 11** Tighten the X1 and X2 Belts. Make sure the Nut closest to the Belt Adjusting Plate is tight. Using a 10mm wrench, hold the Adjustment Nut and turn the Machine Screw to tighten the Belt. Be sure to adjust both Screws the same amount until the Belt is tight.





Repeat these steps to tighten the X2 Belt.

Step 12 Tighten the Y Belt

- 12a** Insert the M4 x 30 Machine Screw through the large hole in the Y Rail Stop as shown. Thread the Screw into the Nut of the Y Adjuster Assembly. Tighten the Belt by turning the Screw clockwise.

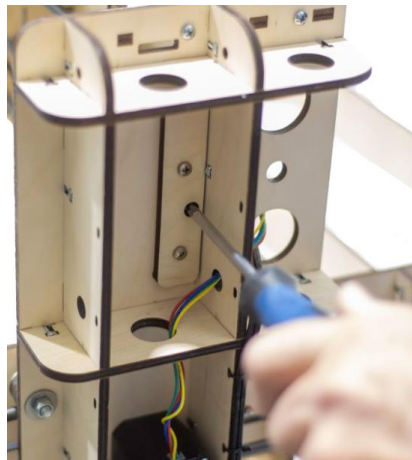

- 12b** Tighten the Screw on the Idler Pulley to secure Belt tension as shown



Make sure the Nut closest to the Belt Adjusting Plate is tight. Using a 10mm wrench, hold the adjustment Nut and turn the Machine Screw to tighten the Belt. Be sure to adjust both Screws the same amount until the Belt is tight.

Step 13 Secure Power and USB Cords





- 13a** Secure the Power Cords to the Wire Harness Support with four Zip Ties as shown





- 13b** Secure the USB cord to the Wire Harness Support with four Zip Ties as shown.

T-Slot Spoilboard

Wood Components

Part #	Description	Qty	Photo
SB1	Fastening Strip	11	 A long, thin, light-colored strip with four small, dark rectangular markings spaced evenly along its length.
SB3	T-Slot Small Board	2	 A long, thin, light-colored board with a series of small, dark circular holes spaced evenly along its length.
SB4	T-Slot Large Board	8	 A long, thin, light-colored board with a series of small, dark circular holes spaced evenly along its length, similar to SB3 but longer.
SB7	Spacer Strips (set)	9	 Two long, thin, light-colored strips with a wavy, zig-zag pattern along their length.

Required Hardware

Part #	Description	Qty	Photo
H9	1.25" Woodscrews	110	 A single, dark-colored wood screw with a sharp point and a wide, flat head.
H14	M4 X 16 Machine Screws	44	 A single, silver-colored machine screw with a hexagonal head and a threaded shaft.
H80	M4 Square Nuts	44	 A single, dark-colored square nut with a central hole.

Step 1 Insert four M4 Square Nuts into each of the T-Slots in the SB1 Fastening Strip.



Step 2 Use one of the T Slot Small Strip Board (SB3) to determine on which side of the frame support to install the mounting strips. are properly positioned to attach the T-Slot boards. Position the strip with the notched line at the rear of the frame assembly. Use the predrilled holes (circled below) in the strip to determine the side on which the Fastening Strips (SB1) will be mounted

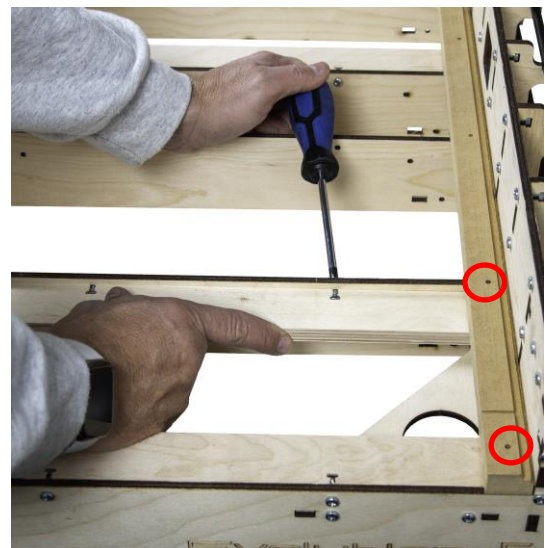
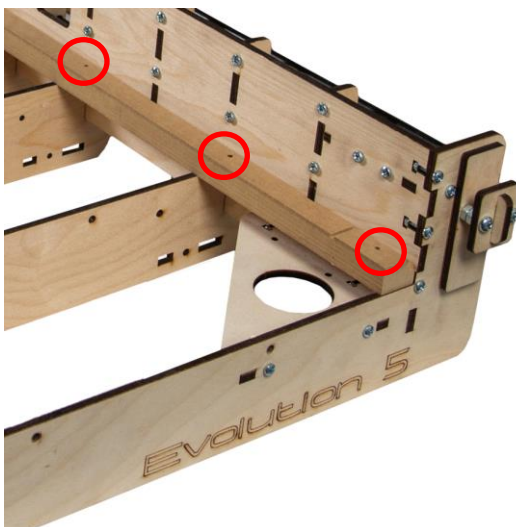

Step 3

Carefully align the T-Slots with the mounting holes in the Rail Support and secure with four M4 x 16 Screws. Make sure the Fastening Strip is mounted on the inside of the X Frame Front.

Before tightening, make sure the Fastening Strips are mounted so that the X Frame supports are slightly proud. This will allow the T-Slot Boards to fastened flush against each of the top edge of the frame supports.



Step 3

Repeat to install the next fastening strip until all eleven strips are installed.



Step 4 Before installing the Spoilboard, it is important to make sure the X Frame is square. The simplest way to do this is to measure diagonally from one corner of the cutting area to the other. If the measurements are exactly the same the X-Frame is square. If not, gently rack the frame until the measurements are equal.



Step 5 Join two Spacer strips together using the scarf joint ends.

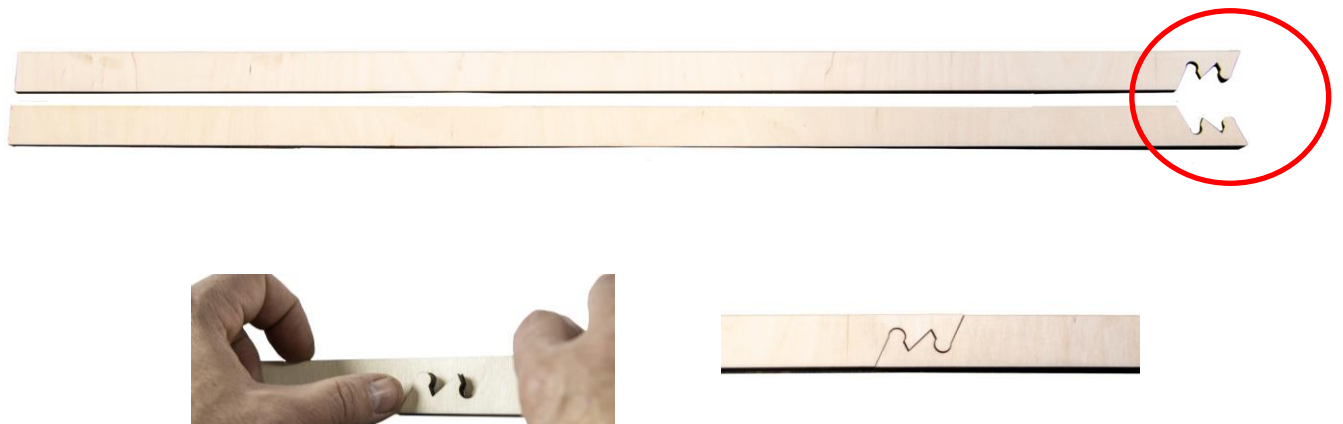

Step 6

Install the T-Slot Small Board (SB3) along the left side of the frame with the notch facing down as shown. Next, install the Spacer Strip Assembly so that it lies beneath the bottom notch of the T-Slot Board.

The Spoilboard will fit flush with the front of the CNC.



Step 7

Repeat, using T-Slot Large Board (SB4), making sure the notch is fully seated on top of the Spacer Strip. Repeat the procedure to install the remaining Spacer Strips and T-Slot Boards. Install the remaining T Slot Small Board(SB3) is installed to the right side. Make sure the T Slot Boards and Spacer Strips are lying flat on the X Frame Assembly Cross Members.

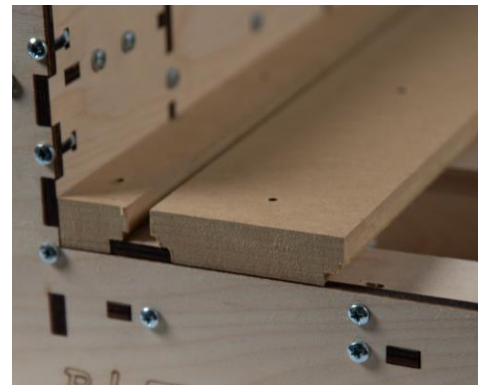
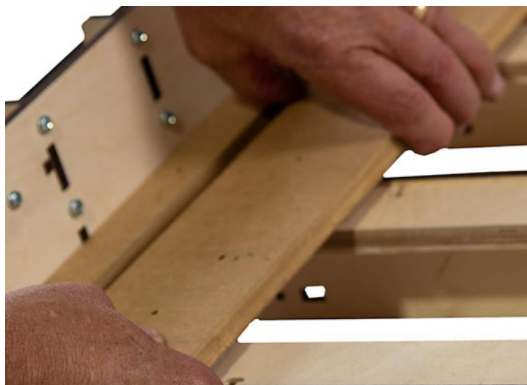

Step 8

Make sure the T Slot Small Boards are tight against each side. Then using the 1¼ inch Wood Screws, secure the Spoilboard to the X-Frame Assembly. We recommend counter sinking the cabinet screws approx. 3/16" below the surface of the T-Slot Boards. Insert the first wood screw in the middle hole of the MDF, then insert the remaining wood screws working from the center to the front, then center to back.



Completed Views

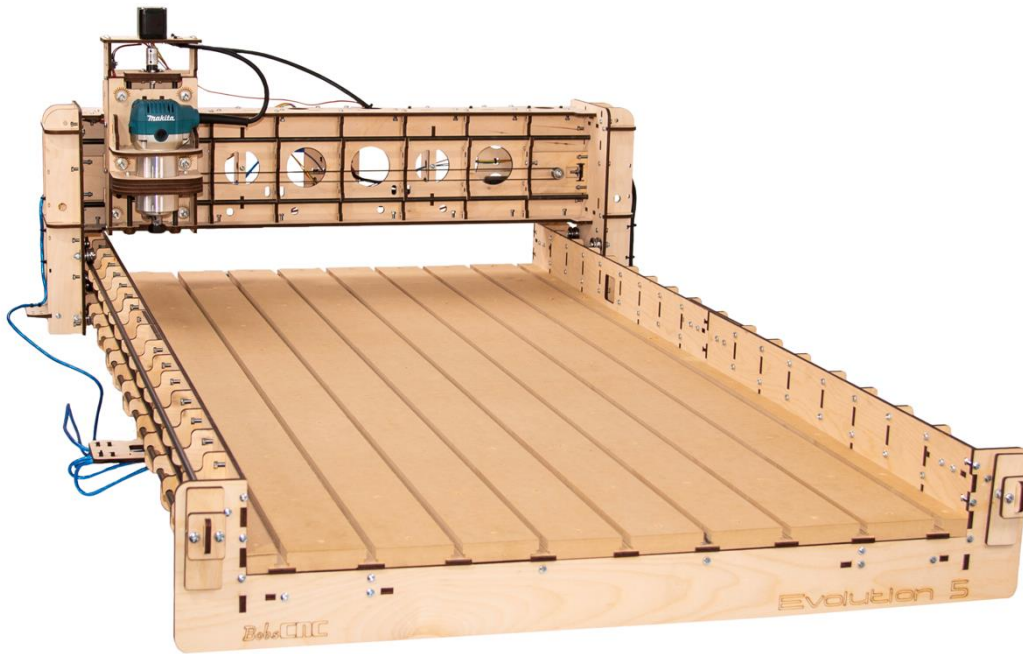

Front View

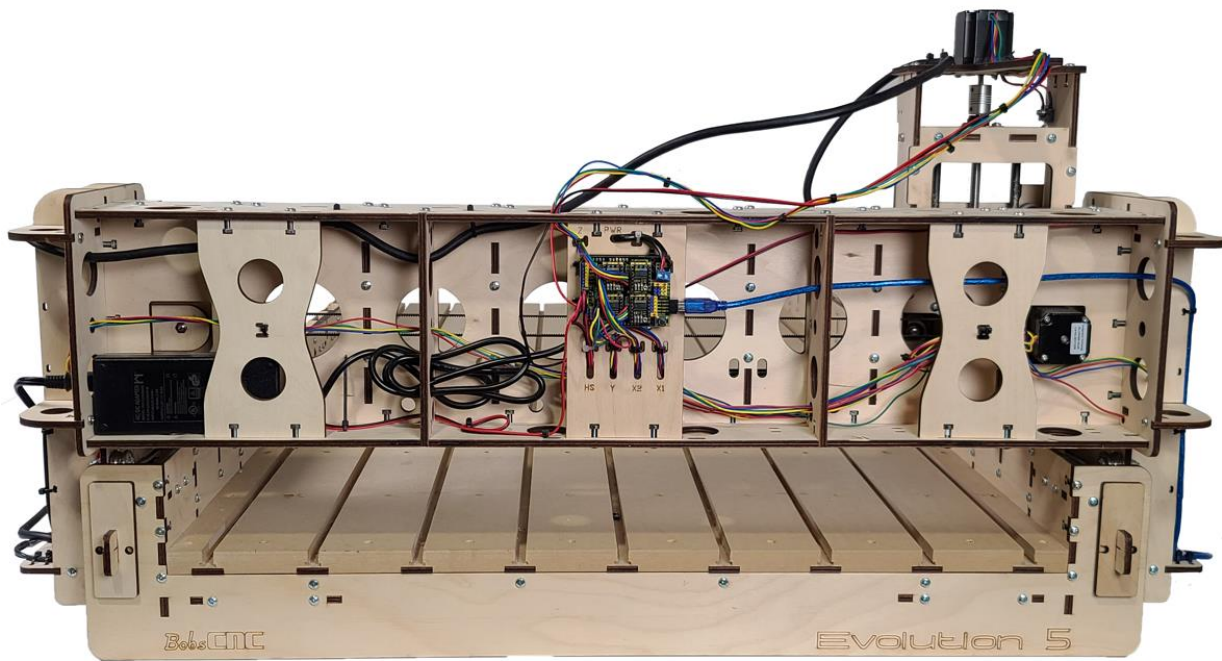

Back View

Belt Adjuster

X1 Side View



X1 Home Switch

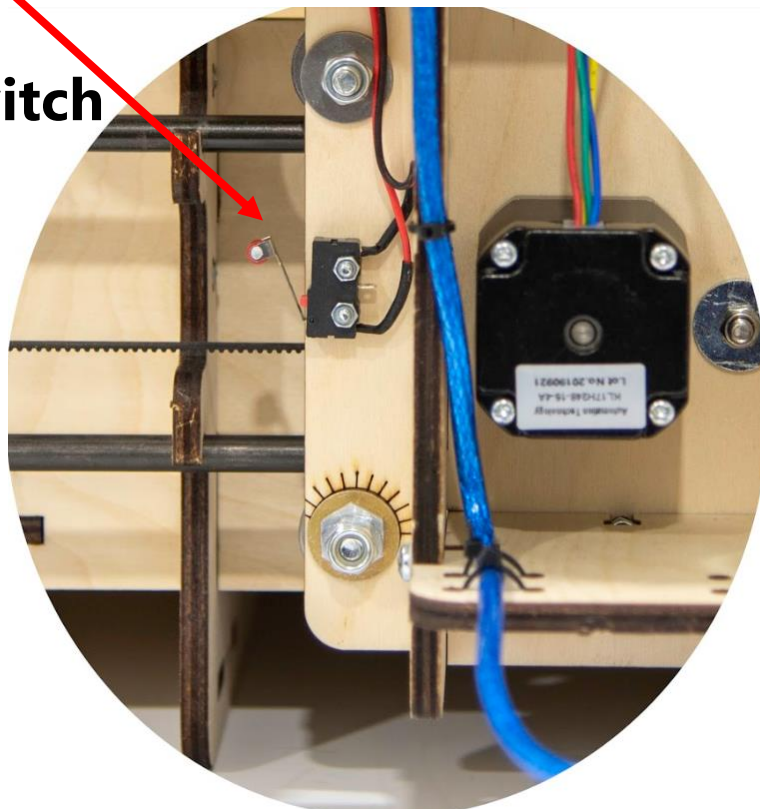

Belt Adjuster

X2 Side View



X2 Home Switch

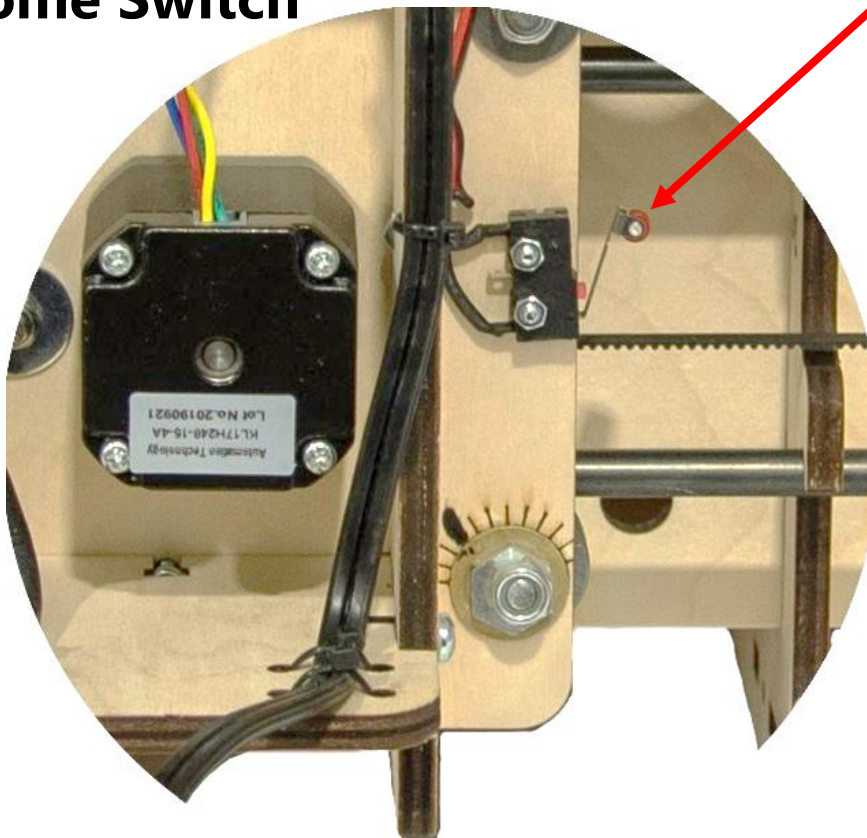

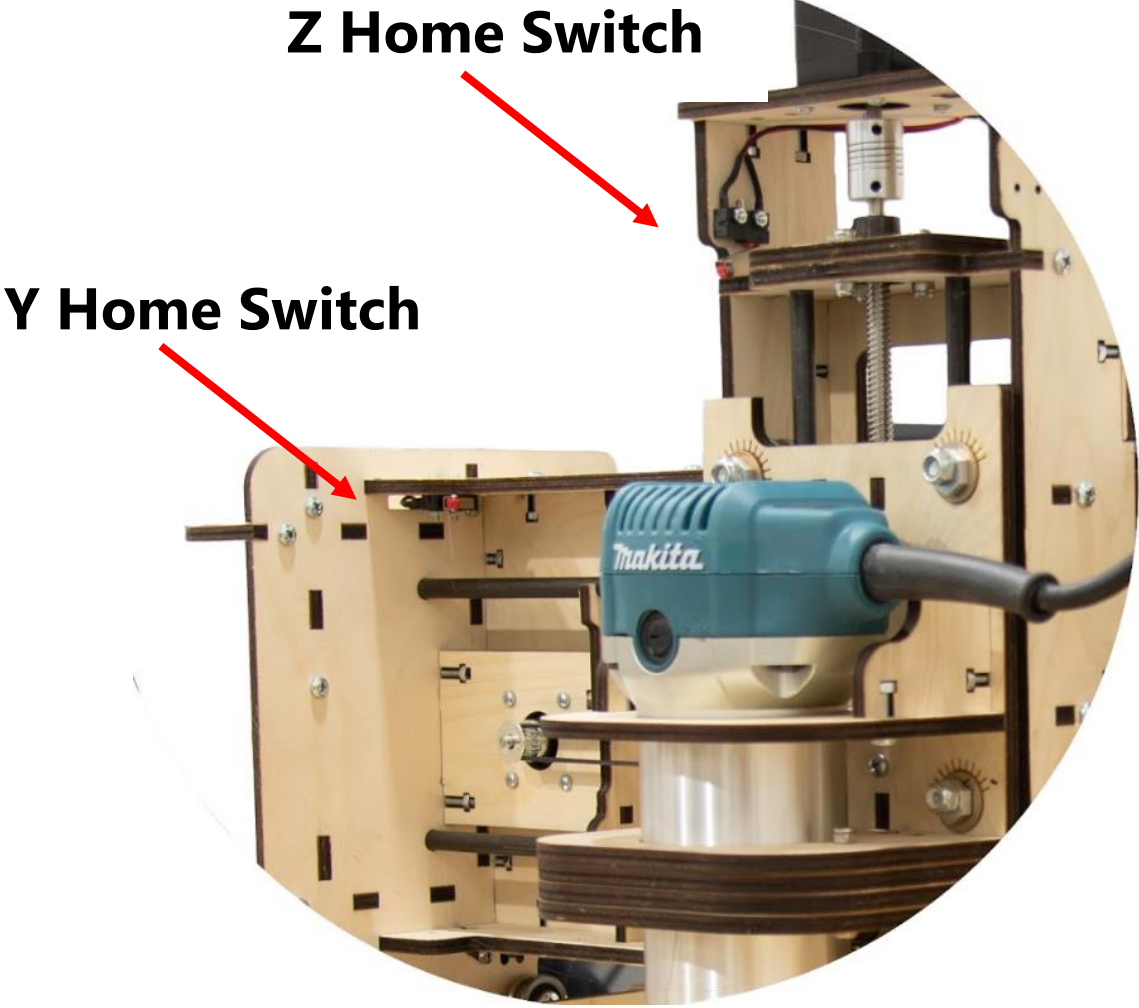

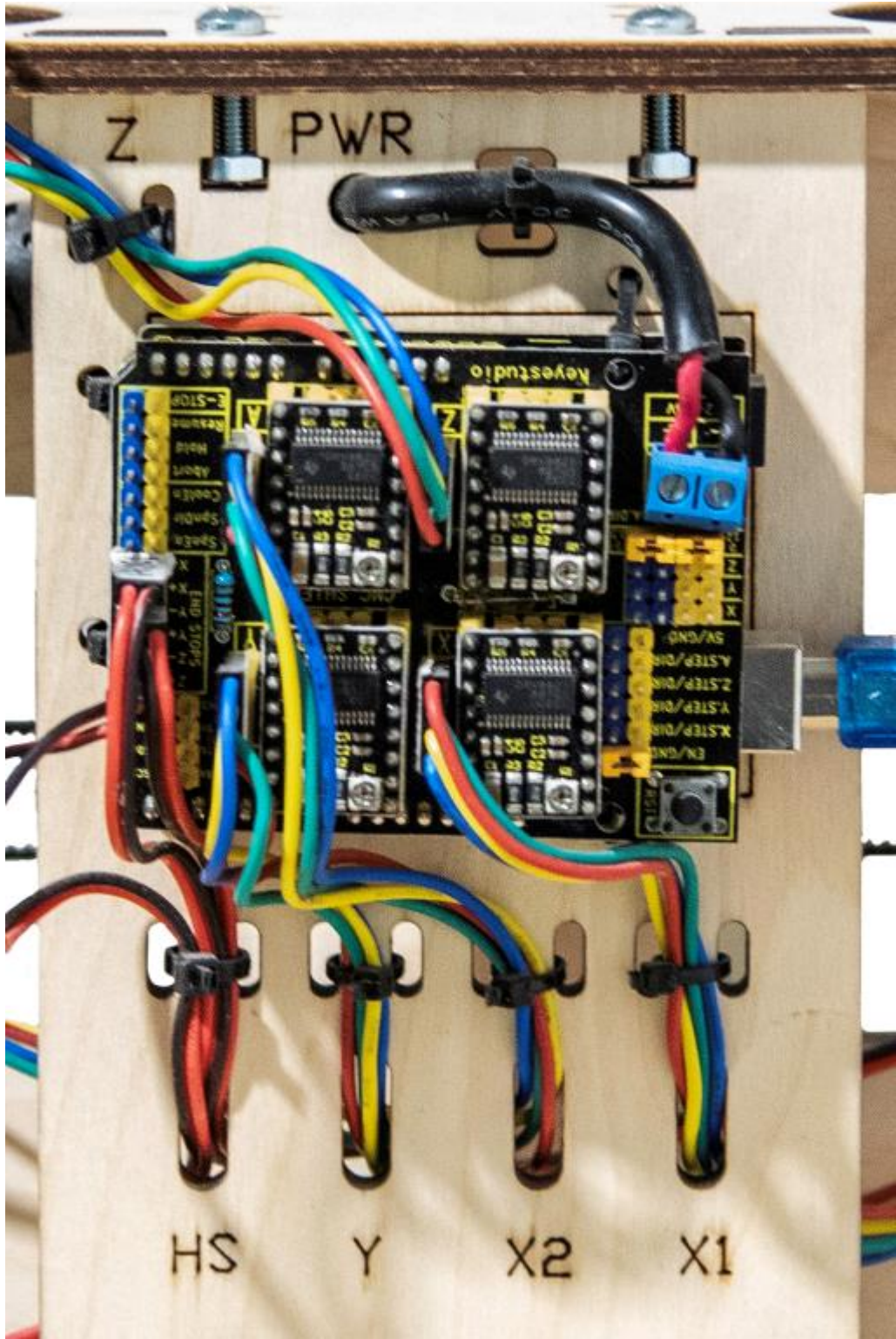

Tramming

Tramming is the process of adjusting a CNC Spindle (Router) so it is perpendicular to the spoilboard. The simplest method to do this is to use a square as shown. If the Spindle is not perpendicular, the Evolution Series CNC Routers can be trammed on the X axis by adjusting the four Eccentric Adjustment Spacers on the Z Carriage.

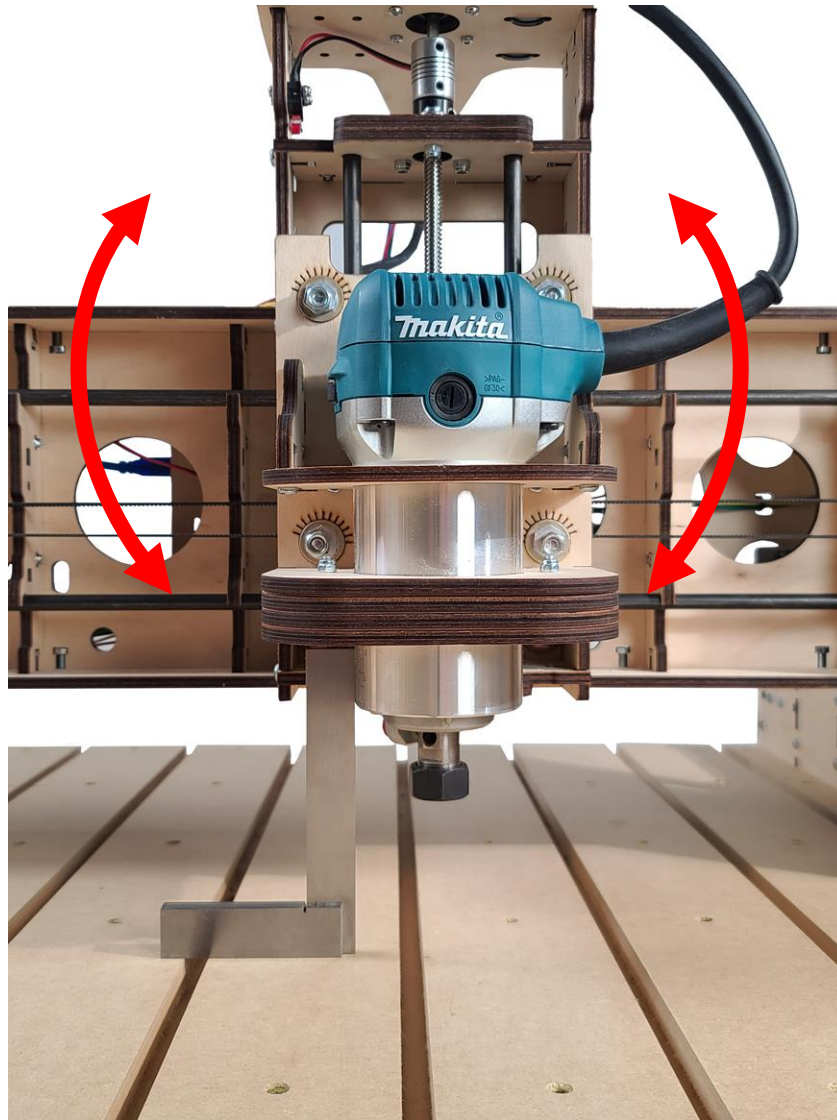

The Spindle (Router) can be trammed on the Y axis by placing shims behind the SG20U Bearing Fender Washer. Placing the shim on the top will tilt the axis clockwise. Placing the shim on the bottom will tilt the axis counterclockwise.

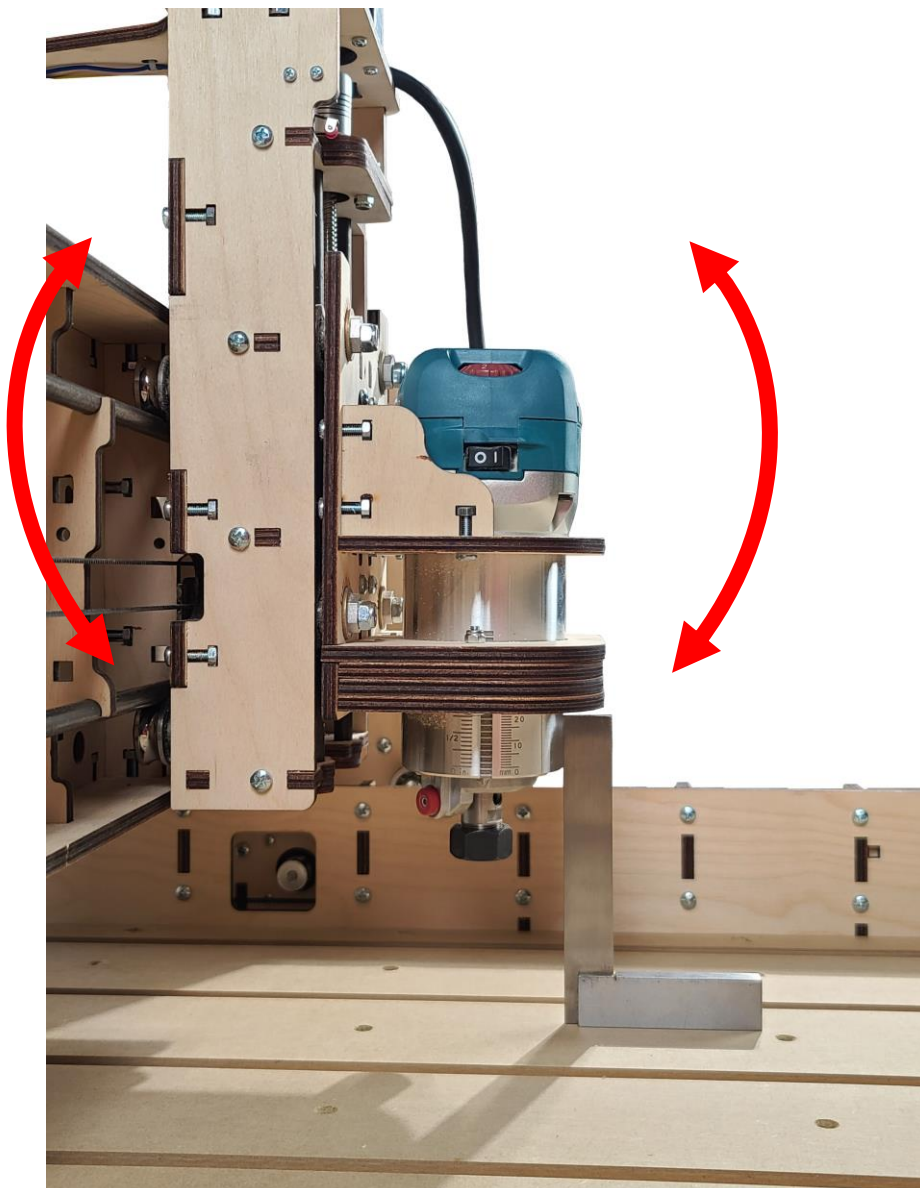

Clamping System

Wood Components (Included with Kit)

Part #	Description	Qty	Photo
A1	Clamp (long)	4	
A2	Clamp (short)	4	

Required Hardware

Part #	Description	Qty	Photo
H9	1/4- 20, 2" Screw & Wingnut	8	

The Evolution Series uses wooden clamps that screw into the inserts in the spoilboard to hold the workpiece in position during the cutting process.

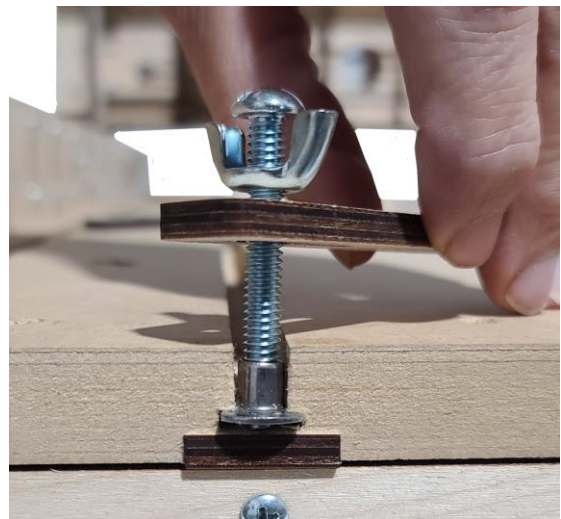

Congratulations! You Just Completed the Assembly of Your Evolution 5.

Please review the Software Setup Guide for Software installation and setup.

Updating Firmware

Evolution 5 Firmware Value Change

Connect the CNC to the USB and connect to UGS Platform. Type in `$130=1283` in the command textbox of the console window of UGS and press the enter key. This will change the soft limit for the X axis to the new value of 1283mm (50.5")

The screenshot displays the Universal Gcode Platform (UGS) software interface. The main window is titled "Universal Gcode Platform (Version 2.0.7-SNAPSHOT / Dec 02, 2020)". The interface is divided into several sections:

- Controller State (DRO):** Shows an "ALARM" status in a red box. The X, Y, and Z axes are all at 0.000. The FEED RATE and SPINDLE are also at 0. The command "G0 G21 G94 G90 G54 G17" is displayed, along with an "ALARM" button.
- Visualizer:** A 2D grid view showing the X and Y axes. A yellow dot is positioned at the origin (0,0). The Z-axis is represented by a vertical line.
- Console:** A list of machine parameters is shown, including:
 - \$102 = 400.000 (Z-axis travel resolution, step/mm)
 - \$110 = 10000.000 (X-axis maximum rate, mm/min)
 - \$111 = 10000.000 (Y-axis maximum rate, mm/min)
 - \$112 = 2000.000 (Z-axis maximum rate, mm/min)
 - \$120 = 500.000 (Y-axis acceleration, mm/sec²)
 - \$121 = 500.000 (Y-axis acceleration, mm/sec²)
 - \$122 = 500.000 (Z-axis acceleration, mm/sec²)
 - \$130 = 610.000 (Y-axis maximum travel, millimeters)
 - \$131 = 610.000 (Y-axis maximum travel, millimeters)
 - \$132 = 85.000 (Z-axis maximum travel, millimeters)
- Command Line:** The command "\$130=1283" has been entered and executed. The console shows the response: "ok [G0 G54 G17 G21 G90 G94 M9 T0 F0] [Error] Error while processing response -ok>: An unexpected command was completed by the controller."

Appendix (\$130=1283)

Evolution 5 Firmware Values

Key	Value	Description
\$0	10	(step pulse, usec)
\$1	25	(step idle delay, msec)
\$2	0	(step port invert mask:00000000)
\$3	0	(dir port invert mask:00000000)
\$4	0	(step enable invert, bool)
\$5	1	(limit pins invert, bool)
\$6	0	(probe pin invert, bool)
\$10	1	(status report mask:00000011)
\$11	0.01	(junction deviation, mm)
\$12	0.002	(arc tolerance, mm)
\$13	0	(report inches, bool)
\$20	1	(soft limits, bool)
\$21	0	(hard limits, bool)
\$22	1	(homing cycle, bool)
\$23	3	(homing dir invert mask:00000011)
\$24	250	(homing feed, mm/min)
\$25	2000	(homing seek, mm/min)
\$26	250	(homing debounce, msec)
\$27	5	(homing pull-off, mm)
\$30	1000	Maximum spindle speed, RPM
\$31	0	Minimum spindle speed, RPM
\$32	0	Laser-mode enable, boolean
\$100	80	(x, step/mm)
\$101	80	(y, step/mm)
\$102	400	(z, step/mm)

\$110	10000	(x max rate, mm/min)
\$111	10000	(y max rate, mm/min)
\$112	2000	(z max rate, mm/min)
\$120	500	(X-axis acceleration, mm/sec ²)
\$121	500	(Y-axis acceleration, mm/sec ²)
\$122	500	(Z-axis acceleration, mm/sec ²)
\$130	1283	(X-axis maximum travel, millimeters)
\$131	610	(Y-axis maximum travel, millimeters)
\$132	85	(Z-axis maximum travel, millimeters)

Evolution Washer Dimensions

Part number	Description	ID	OD	Thickness (min)	Thickness (max)
H41	Eccentric Washer	0.453	0.750	0.059	0.063
H42	Bearing Fender Washer	0.250	0.750	0.060	0.090
H50	Idler Fender Washer	0.203	0.750	0.043	0.051
H57	Bearing Retainer Washer	0.172	0.050	0.050	0.080
H66	Small Shim Washer	0.256	0.500	0.028	0.035