

# BobsCNC

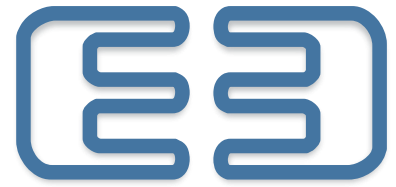

Simple Cost Effective Designs

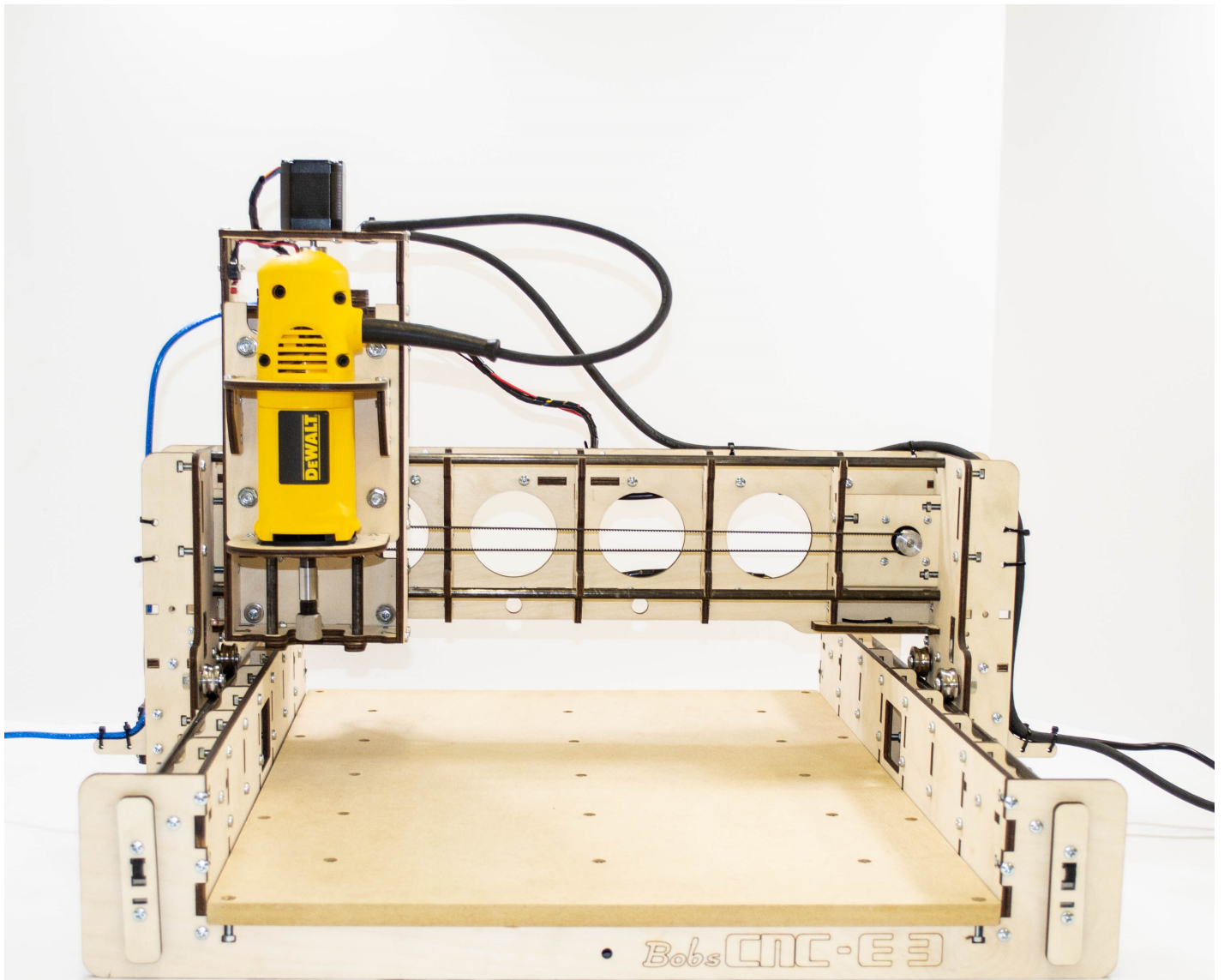

## Assembly Manual

Version 2.15

Page 1

|  |              |
|--|--------------|
| Table of Contents                                    |              |
| Specifications                                       | 4            |
| Safety First   |              |
| Getting Started                                      | 5            |
| Required Tools                                       |              |
| Good Ideas   |              |
| For More Information                                 |              |
| E3 Hardware Parts Guide                              | 6            |
| <b>Z-Spindle Mount Assembly Instructions</b>         | <b>7-17</b>  |
| Wood Components (included with the kit)              |              |
| Required Hardware (included with the kit)            |              |
| Illustrated Steps                                    |              |
| <b>Y Carriage Assembly Instructions</b>              | <b>18-37</b> |
| Wood Components (included with the kit)              |              |
| Required Hardware (included with the kit)            |              |
| Illustrated Steps                                    |              |
| <b>Frame Assembly Instructions</b>                   | <b>38-42</b> |
| Wood Components (included with the kit)              |              |
| Required Hardware (included with the kit)            |              |
| Illustrated Steps                                    |              |
| <b>Gantry Assembly Instructions</b>                  | <b>43-55</b> |
| Wood Components (included with the kit)              |              |
| Required Hardware (included with the kit)            |              |
| Illustrated Steps                                    |              |
| <b>Gantry Electronic and GT2 Pulley Instructions</b> | <b>56-60</b> |
| <b>Gantry Installation Instructions</b>              | <b>61-64</b> |
| Wood Components (included with the kit)              |              |
| Required Hardware (included with the kit)            |              |
| Illustrated Steps                                    |              |
| <b>Y Carriage Installation Instructions</b>          | <b>65-69</b> |
| Wood Components (included with the kit)              |              |
| Required Hardware (included with the kit)            |              |
| Illustrated Steps                                    |              |

|   |       |
|---|-------|
| <b>Installing the Belts</b> .....                     | 70-74 |
| Wood Components (included with the kit)               |       |
| Required Hardware (included with the kit)             |       |
| Illustrated Steps                                     |       |
| Installing the Spoilboard .....                       | 75-76 |
| Initial Setup .....                                   | 76-79 |
| Tips to Keep Your Controller from being Damaged ..... | 80-81 |
| GRBL and Universal G Code Sender Software.....        | 82    |
| Quick Start Guide.....                                | 83-84 |
| Appendix .....  | 85-90 |
| Warranty and Return Policy .....                      | 85    |
| Miscellaneous Parts List.....                         | 86    |
| Frame Parts Diagram .....                             | 87    |
| Gantry Parts Diagram.....                             | 88    |
| Y Carriage Parts Diagram.....                         | 89    |
| Z Parts Diagram.....                                  | 90    |

## Specifications

The E3 CNC Engraver has the following features:

- Rigid laser cut frame.
- Fully supported rail system with SG20U bearings.
- GT2 belt drive on X and Y axis.
- 5/16-18 coupler nut on the Z axis.
- Home switches on all axes.
- MDF Spoilboard with 1/4-20 threaded inserts.

The assembled footprint:

Length: 24.8" (630 mm)  
Width: 25.2" (640 mm)  
Height: 18.9" (480 mm)

Assembled Weight:

25 lbs.

Cutting Area:

X: 17.7" (450 mm)  
Y: 15.3" (390 mm)  
Z: 3.3" (85 mm)

The complete E3 parts list can be found in the appendix.



### **Safety First**

**Safety is *your* responsibility. Use the proper protective equipment and "safety sense" when building and operating your CNC Router.**

Routers have a high voltage power supply. Router bits spin at 30,000 rpm and have cutting edges that are hazardous. The operator should understand these hazards and take appropriate safety precautions before operating the Router.

**Please review the entire assembly instructions before starting to build the E3 CNC Router.**



# Getting Started

## Required Tools

To assemble the kit together you will need the following:

- Two ½" end wrenches to tighten Z Bearing nuts.
- A pair of long nose pliers to hold the nuts.
- Diagonal Cutters or sharp knife to trim nylon ties.
- Calipers or measuring tape to measure part placement.
- Small standard screwdriver to connect electronics.
- Small Phillips screwdriver to mount home switches and stepper motors.
- Medium Phillips screwdriver to build the main components.
- Sand paper to remove laser marks on the faces.
- M4 Star Driver for DeWalt disassembly.
- LOCTITE 243 thread lock (fingernail polish can be used as a substitute).

To operate the E3 CNC Router you will need:

7/16" & 5/8" wrench to change router bits.

Computer with control software for GRBL.

Build material.

1/8" or 1/4" Router bits.

Dry lubrication (e.g., graphite, Teflon or silicon spray).

Tools you may need for the electronic setup include:

Multimeter to correctly connect the power supply and stepper motors. A multimeter is also a good tool to have for general electronic trouble shooting.

### Look for Good Ideas



- We recommend using a large flat, clean working surface for assembling your E3.
- All screws (unless noted) should be installed snug, then rotated one 1 to 2 1/2 turns.
- Light sanding of the wood surfaces will clean up the marks made by the laser.
- Painting or applying stain with a clear coat will give added protection to the wood

**\*For More Information: [Click on the Links](#)**

**[Quick Start](#) and [Troubleshooting](#) guides are available to help you get up and running. Please check [BobsCNC.com](http://BobsCNC.com) for the latest version.**



# CAUTION

**Caution: This kit includes small parts that are a choking hazard for small children. Prior and during assembly keep all parts out of the reach of small children.**

## E3 Parts Identification

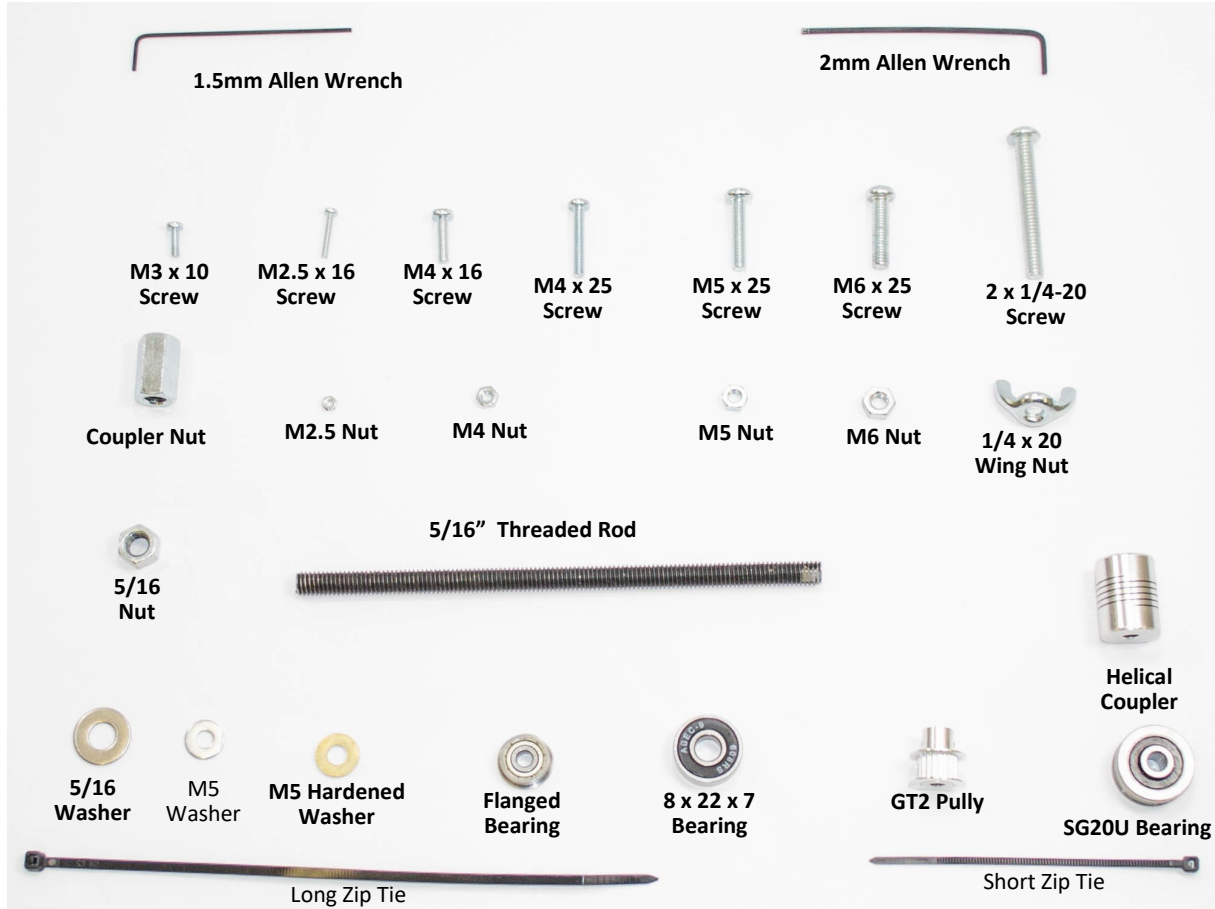

# Z-Spindle Mount Assembly Instructions

## Z-Spindle Mount Wood Components

| Part # | Qty | Component              |
|--------|-----|------------------------|
| Z1     | 2   | Frame Mount Support    |
| Z2     | 2   | Z-Frame Support        |
| Z3     | 1   | Z Frame                |
| Z4     | 1   | Z-Spindle Bottom Mount |
| Z5     | 1   | Z-Spindle Top Mount    |

## Z-Spindle Mount Hardware

| Part # | Qty | Hardware Description   |
|--------|-----|------------------------|
| A      | 1   | Coupler Nut            |
| B      | 1   | Threaded Rod           |
| C      | 2   | 5/16" Washers          |
| D      | 19  | M4 Nut                 |
| E      | 19  | M4 x 16 Screws         |
| F      | 8   | 6mm Hardened Washers   |
| G      | 4   | SG20U Bearings         |
| H      | 4   | M6 x 25mm Screws       |
| I      | 4   | M6 Nuts                |
| J      | 1   | Large Zip Tie          |
| K      | 1   | DeWalt 660 Rotary Tool |

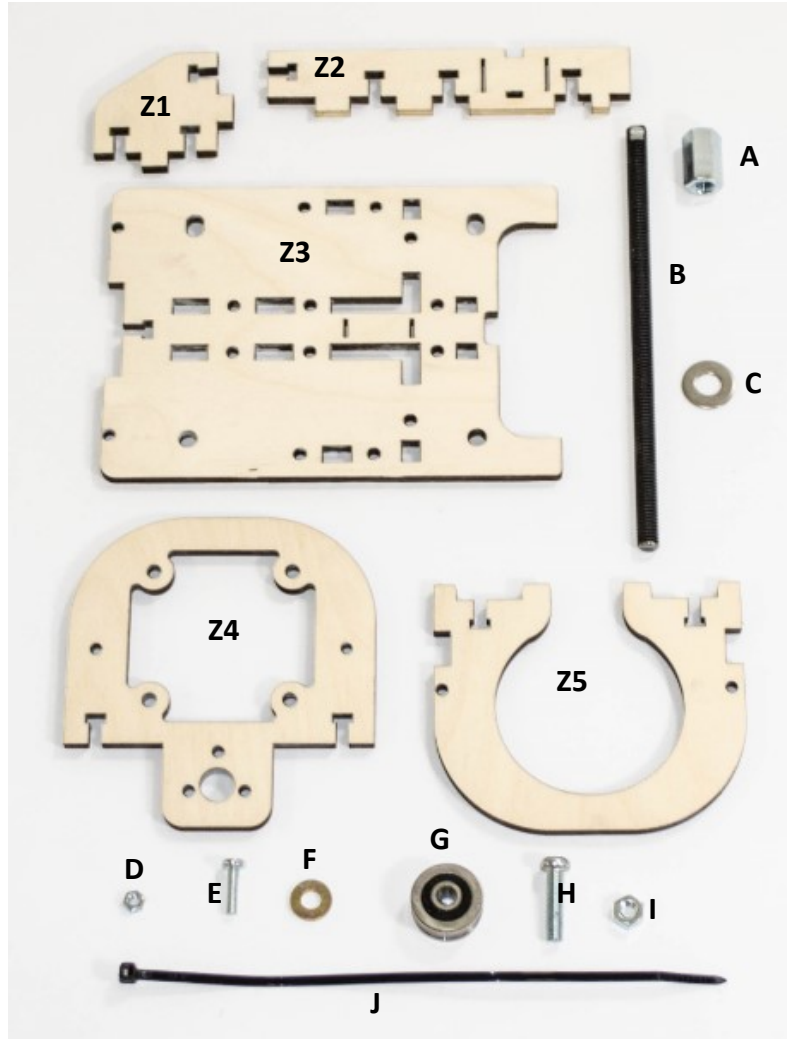

## Step 1

Apply dry lube (graphite, Teflon, or silicon) to the threads of the threaded Rod.



IT IS A GOOD IDEA TO APPLY DRY LUBE TO THE THREADED ROD ONCE A MONTH . DRY LUBE IS A GOOD LUBRICANT FOR THE DUSTY ENVIRONMENT CREATED WHEN OPERATING YOUR E3 CNC.

## Step 2

Thread the Coupler Nut on the threaded rod in the order as shown below: steel washer > Coupler nut > steel washer (see photo below).

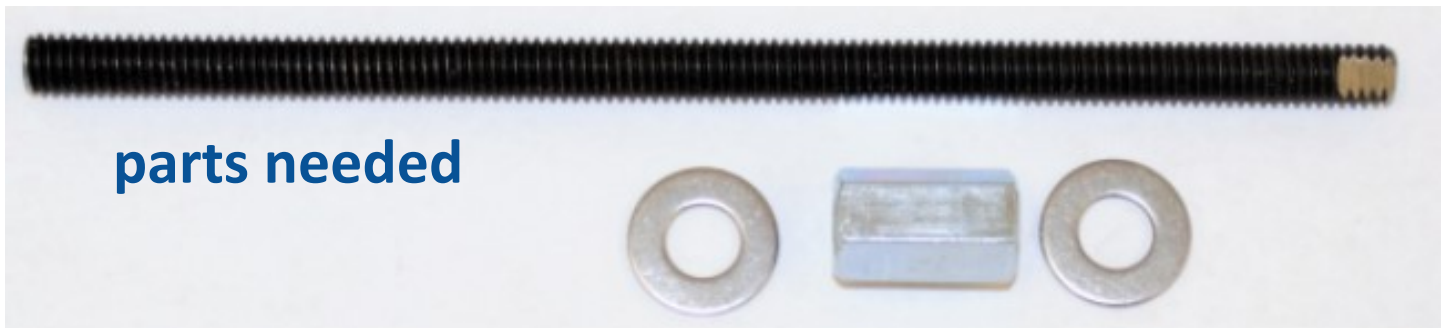

## Step 3

Insert the washer and nut assembly in the Z Frame Support Slots.



## Step 4

Position second Z Frame Support on top of the washer and nut assembly.

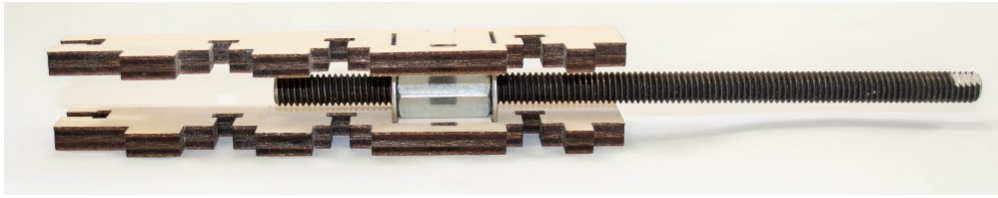

## Step 5

Set tabs of Z Frame Supports in the corresponding Z Frame slots.

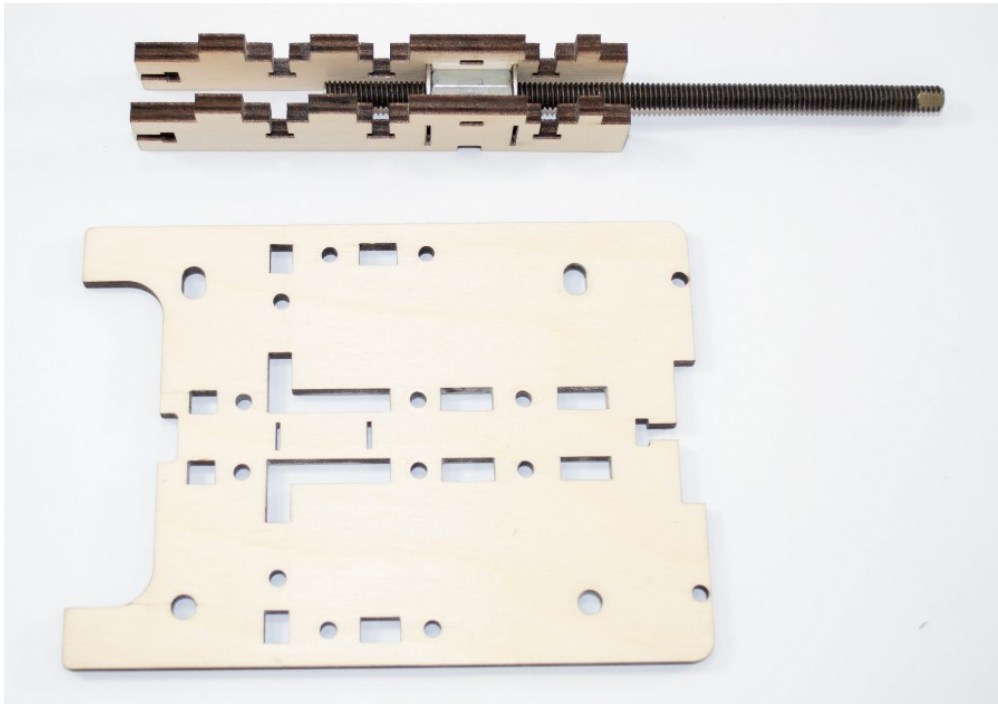

(The assembly should look like this).

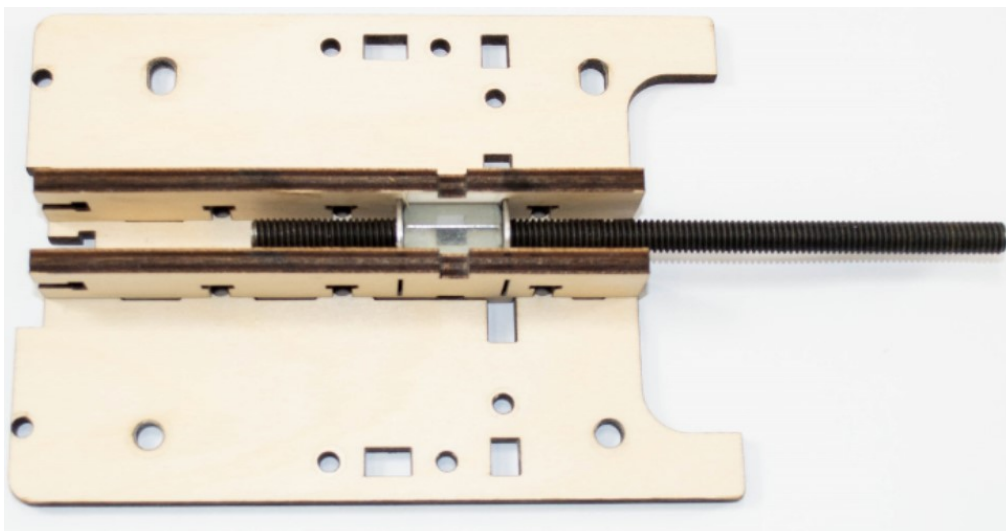



## Step 6 Secure Assembly components with six M4 x 16 Screws and Nuts.



Apply LOCTITE to all screws.



All screws (unless noted) should be installed snug, then rotated 1 to 2 1/2 turns.

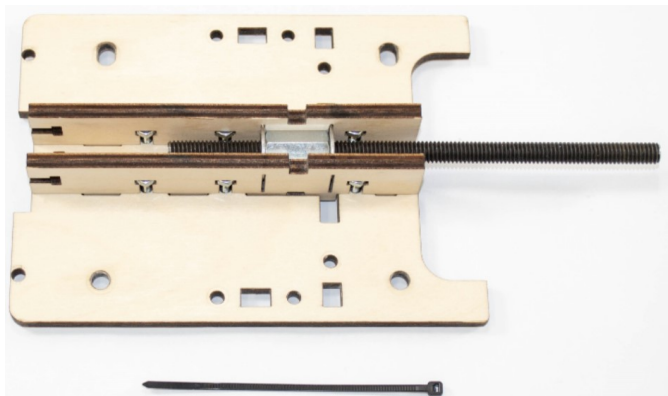

Position the nut in “T” of the T-Slot before inserting screws and tightening.

## Step 7 Thread Large Zip Tie beneath Z Supports and coupler as shown and tighten securely.

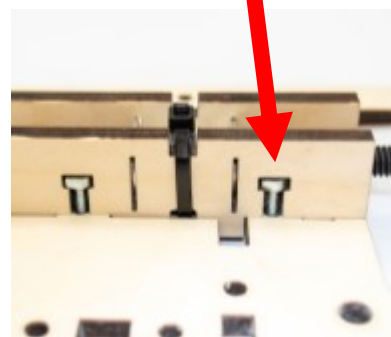
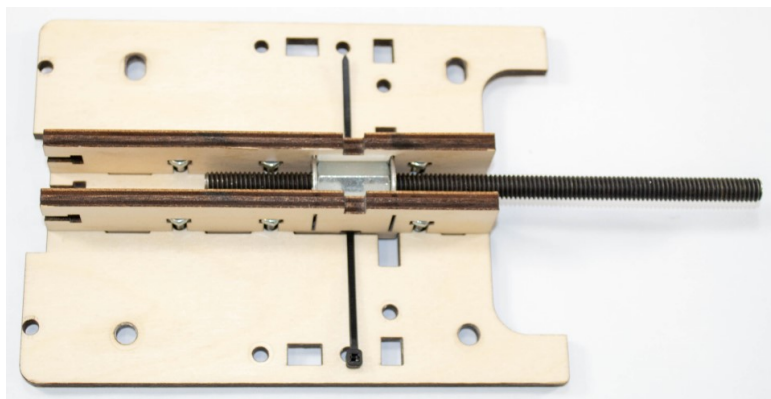

The 5/16 threaded rod should be centered through both washers and turn freely through the coupler nut and not rub on the washers.

## Step 8

Place the Z Spindle Bottom Mount into the Z Frame and secure with five M4 x 16 Screws and Nuts as shown below.



# Step 9

Preparing the DeWalt 660 Rotary Tool for Mounting (see next page for step by step instructions).

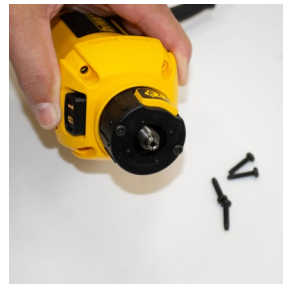



# Step by Step Instruction for preparing the DeWalt 660

- A. Remove guide base assembly.
- B. Remove the Collet Nut.
  - 1. Press and hold down the Spindle Lock.
  - 2. Use wrench to loosen Collet nut.
  - 3. Remove Collet nut (do not discard the collet or the collet nut).
- C. Remove the Spindle Cover
  - 1. Using a M4 Star Driver remove the four DeWalt attachment screws (DO NOT DISCARD).
  - 2. Gently wiggle and slowly lift the shroud, *be careful not to remove spindle shaft.*
  - 3. Remove Shroud exposing Spindle shaft .



Don't allow the black mount and spindle shaft to slip out of the yellow housing. If this happens you will need to remove the top cover and remove the motor brushes. Then you can reinsert the spindle shaft and re-install the brushes. Please see our [Troubleshooting Guide](#) for instructions on how to correctly remove and replace brushes.



Do not attempt to insert the motor shaft back into the housing without first removing the motor brushes. This will damage the DeWalt brush mount and void the warranty on your DeWalt 660 Rotary Tool .

## Step 10

Place Z Spindle Top Mount over the DeWalt and slide into position.



The Top Mount must be compressed into the correct position so that the slots on the frame are aligned with the Top Mount tabs. Note the position of the cord stress relief ( to the left) The DeWalt name plate will facing up. The ID surface of the top mount may need to be sanded so that it can be squeezed into position.



## Step 11

screws

Using a M4 Star Driver, reinsert the four original DeWalt screws through the mount into the DeWalt as shown below:



## Step 12

Place the Frame Mount Supports into the Z Frame and secure both sides with three M4 x 16 screws and nuts (see below):



## Step 13

Secure the Z Spindle Top Mount with two M4 x 16 screws and nuts as shown.

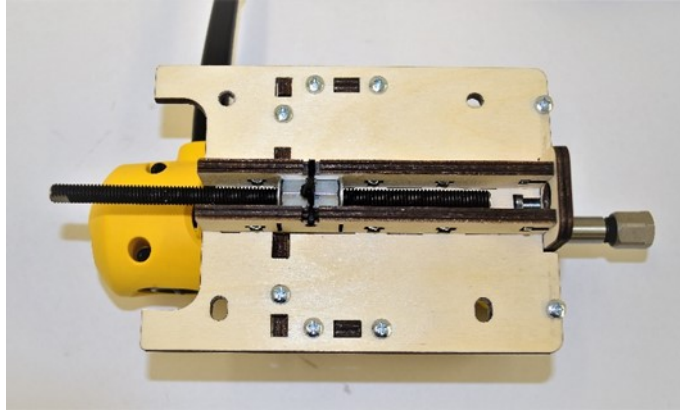

## Step 14

Install two SG20U bearings with the M6 x 25 screws, 6mm washers and M6 nuts. The bearing hubs must face the wood as illustrated below. The screws in the round holes should be installed snug, then rotated two to four turns.



Apply LOCTITE to all screws.



Make sure the hub of the bearing faces the wood. **IMPORTANT:** the screw must be oriented so that the nut is visible when looking at the back of the carriage (see photo below).



Hub



## Step 15

Insert and move the two remaining SG20U bearings in the slotted holes (photo below right) inward and snug the nuts then rotate 1/4 turn. The nuts will be tightened later when the installed on the Y Carriage.

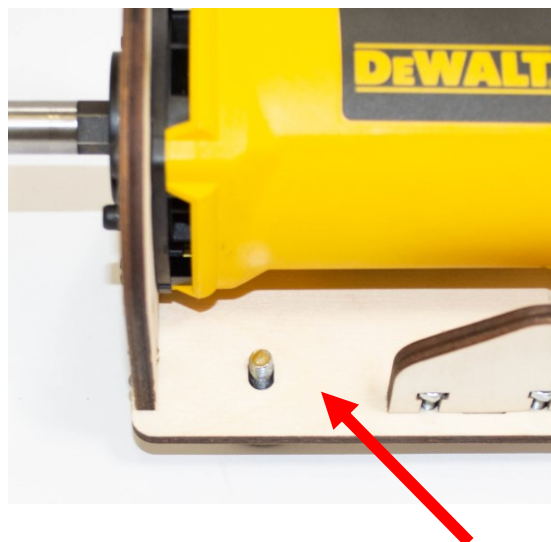
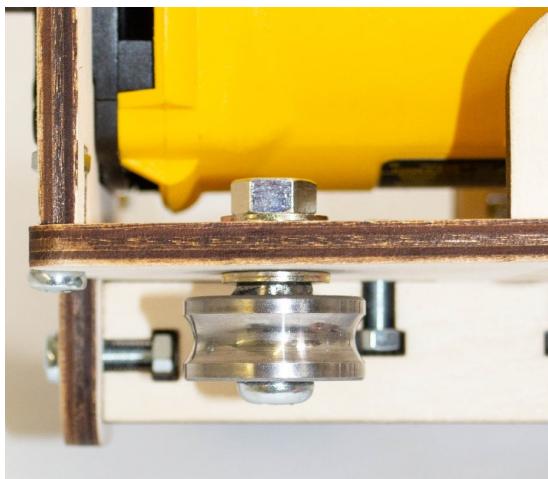

**Completed Spindle Mount Assembly (back view):**

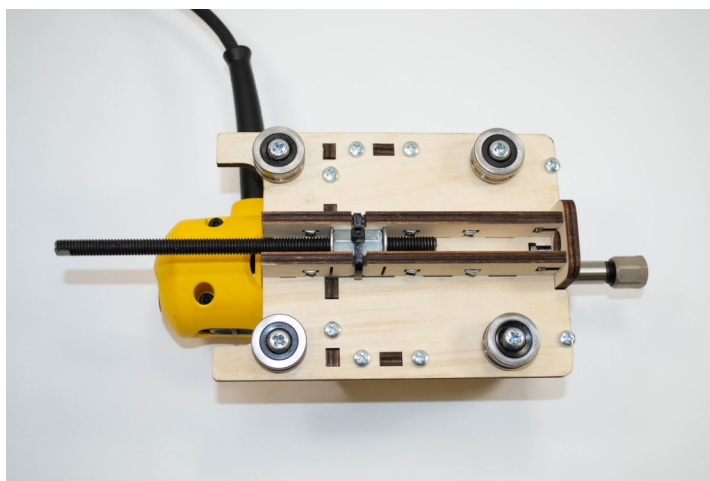

**Completed Spindle Mount Assembly (front view):**

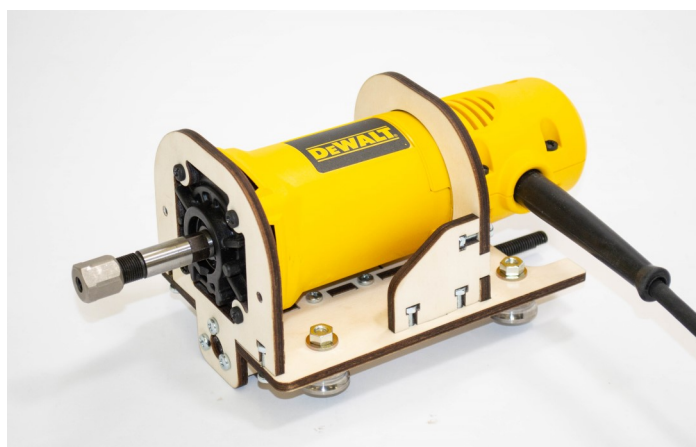

# Y Carriage Mount Assembly Instructions

## Y Carriage Wood Components

| Part # | Qty | Component                 |
|--------|-----|---------------------------|
| Y1     | 1   | Z Stepper Motor Mount     |
| Y2     | 1   | Bearing Bottom Plate      |
| Y3     | 1   | Bearing Top Plate         |
| Y4     | 1   | Bearing Middle Plate      |
| Y5     | 1   | Y Carriage Frame          |
| Y6     | 2   | Y Carriage Side Support   |
| Y7     | 2   | Belt Retainer             |
| Y8     | 1   | Z-Rail Stop               |
| Y9     | 2   | Z-Rail Support            |
| Y10    | 1   | Y Carriage Bottom Support |

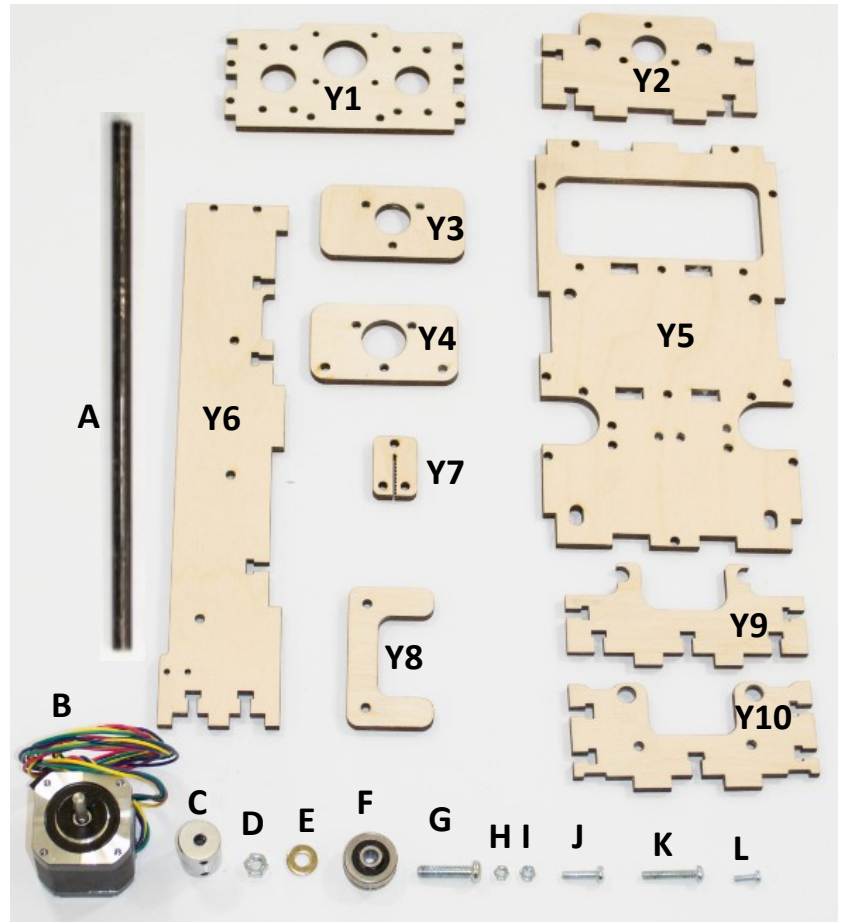

| Part # | Qty | Hardware Description |
|--------|-----|----------------------|
| A      | 2   | Z-Rail               |
| B      | 1   | Stepper Motor        |
| C      | 1   | Helical Connector    |
| D      | 2   | 5/16" Nuts           |
| E      | 8   | 6mm Hardened Washer  |
| F      | 4   | SG20U Bearings       |
| G      | 4   | M6 x 25 Screws       |
| H      | 4   | M6 Nuts              |
| I      | 40  | M4 Nuts              |
| J      | 37  | M4 x 16 Screws       |
| K      | 3   | M4 x 25 Screws       |
| I      | 4   | M3 x 10 Screws       |



Try placing 1" strips of blue painters tape behind the T-Slots to help hold the nuts in place.

All screws (unless noted) should be installed snug, then rotated 1-1/2 to 2 turns.

## Step 1

Place Z Carriage Rail Support into the Y Carriage Frame and secure with three M4 x 16 screws and nuts (see below):

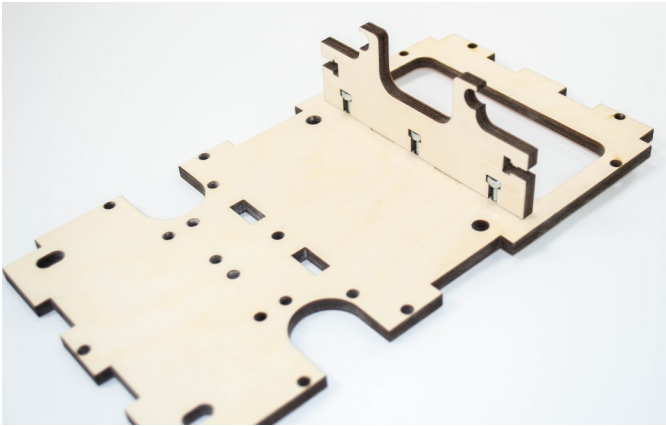

## Step 2

Place second Z Carriage Rail Support into the Y Carriage Frame and secure with three M4 x 16 screws and nuts (see below):

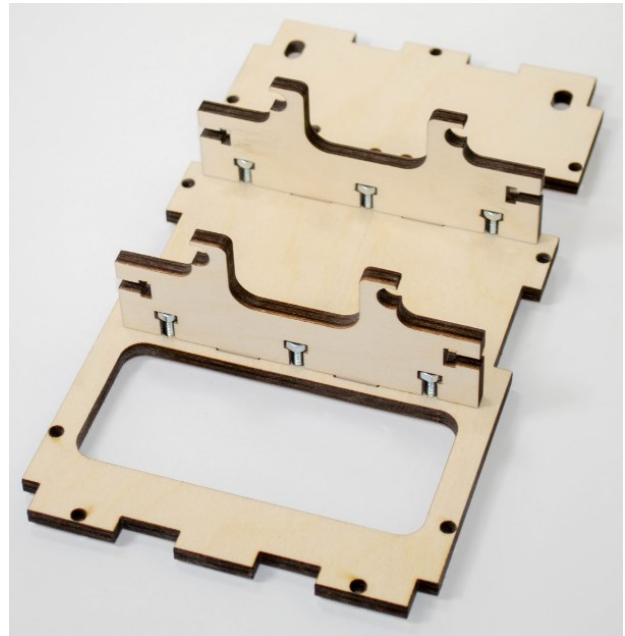

**Step 3** Attach Y Carriage Side Support and secure with five M4 x 16 screws and nuts.

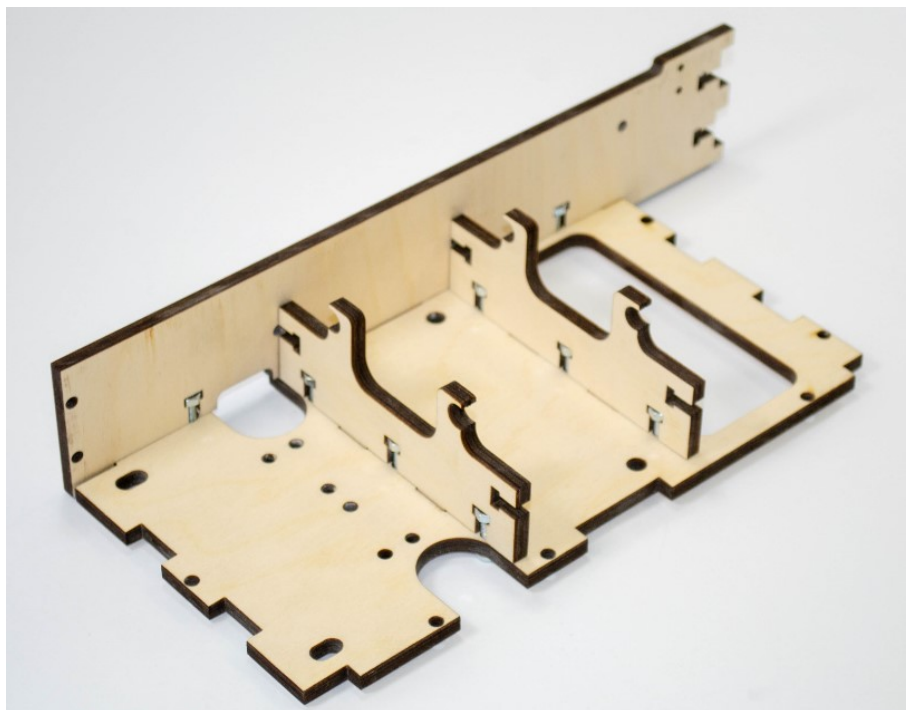

**Step 4** Attach second Y Carriage Side Support and secure with five M4 x 16 screws and nuts.

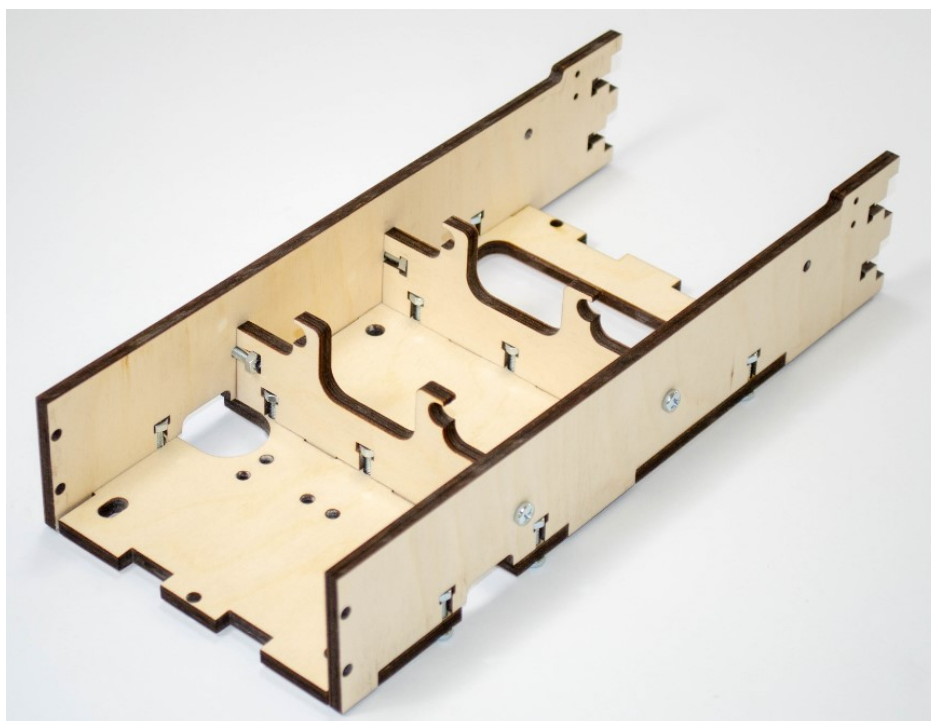



## Step 5

Attach Y Carriage Bottom Support and secure with five M4 x 16 screws and nuts.

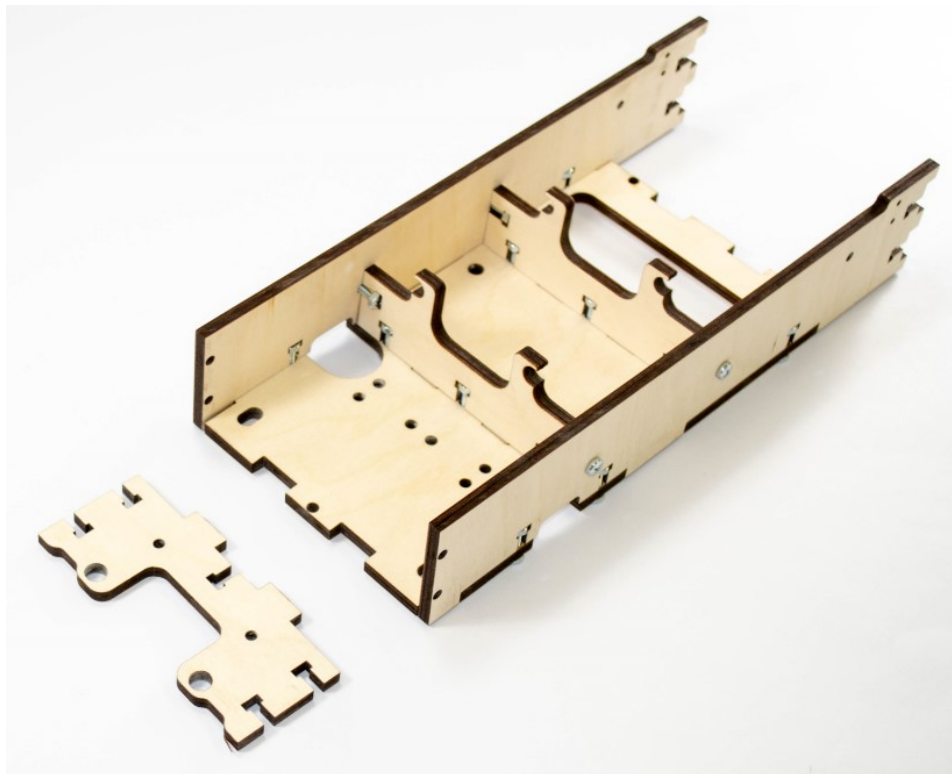

**Step 6** Attach Z Rail Stop and secure with two M4 x 16 screws and nuts.

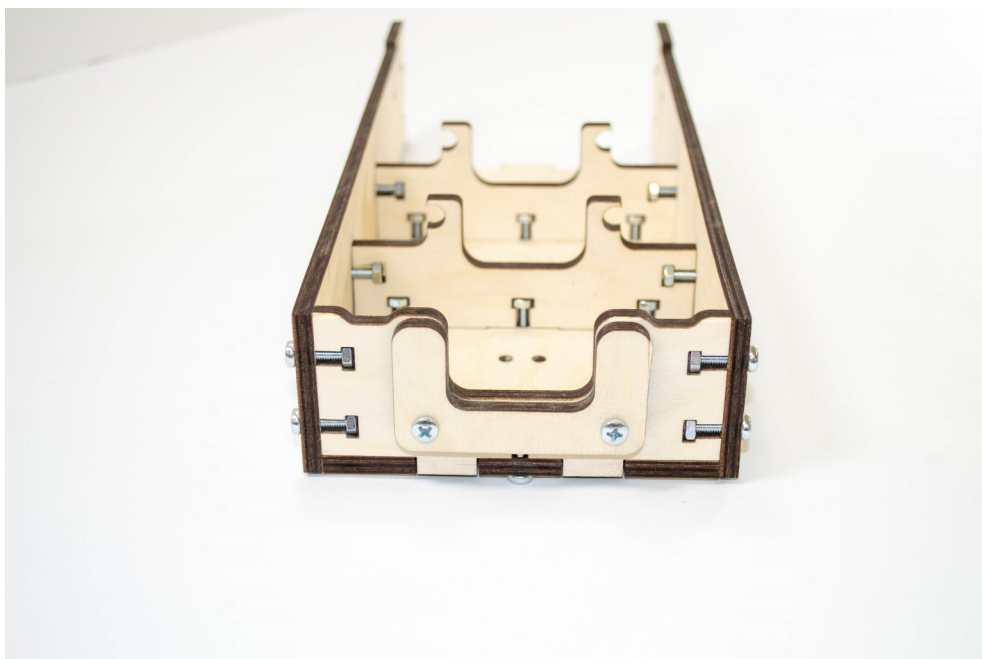

**Step 7** Attach both Belt Retainers and secure with six M4 x 16 Screws and Nuts.



Be sure the tooth profile is on the top, smooth profile bottom (see photo below).

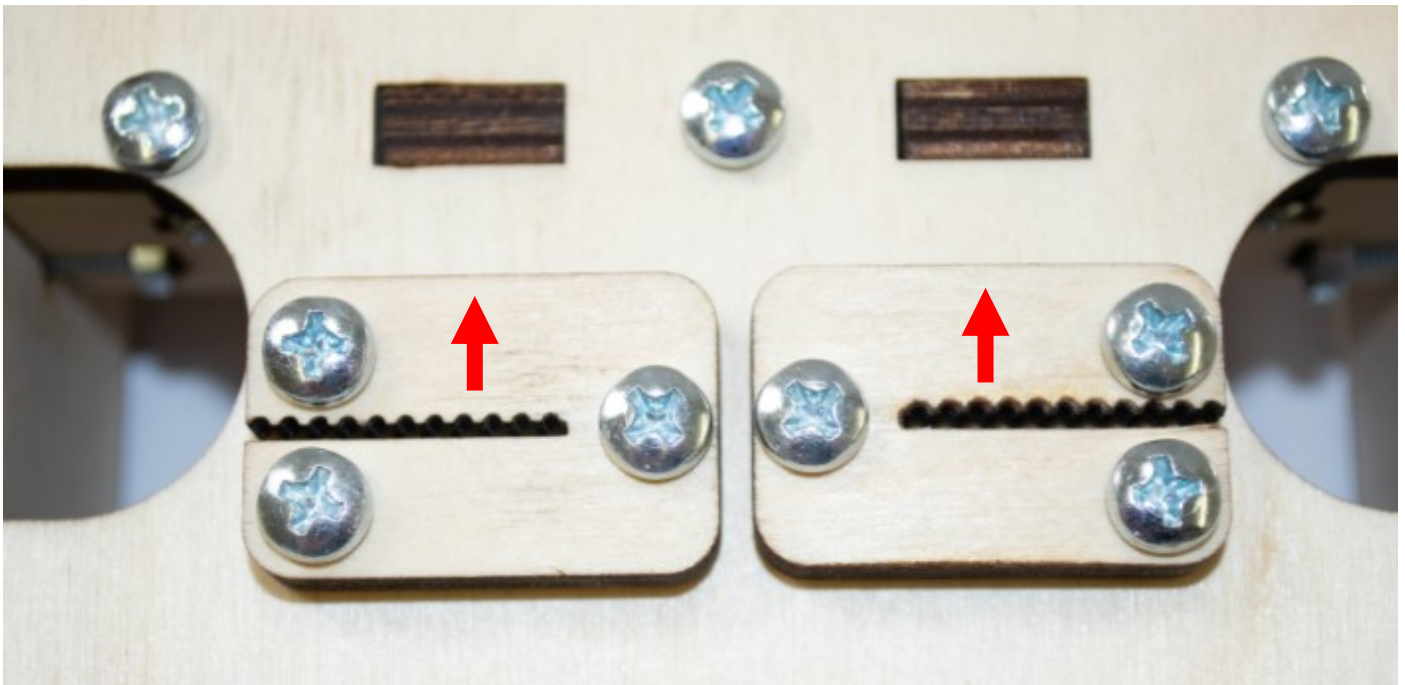

## Step 8

Install four SG20U Bearings using M6 x 25 screws and nuts .



Make sure the hub of the bearing faces the wood. **IMPORTANT:** the screw must be oriented so that the nut is visible when looking at the back of the carriage (see photo below).



Hub



Y Carriage bolt sequence: Screw head / Hardened Washer / Plywood / Hardened Washer / Bearing / Nut







**Notice that the two round and two elongated holes in the Y Carriage Frame (left photo):**

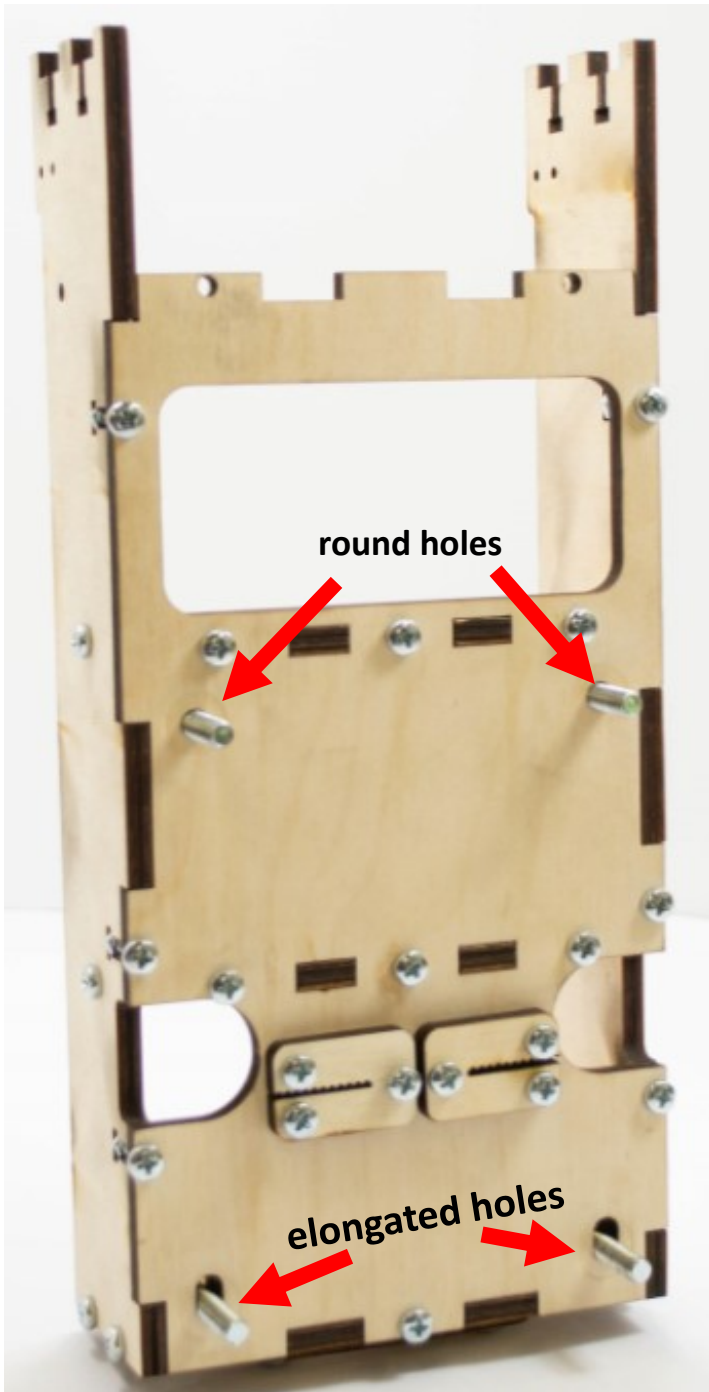

**Insert screw through the hardened washer then through the plywood hole. Next put second washer on the screw then the bearing with the hub against the washer. Last, thread the nut on the screw and snug, the rotate two to four turns**

The finished installation of the bearings should look like this:

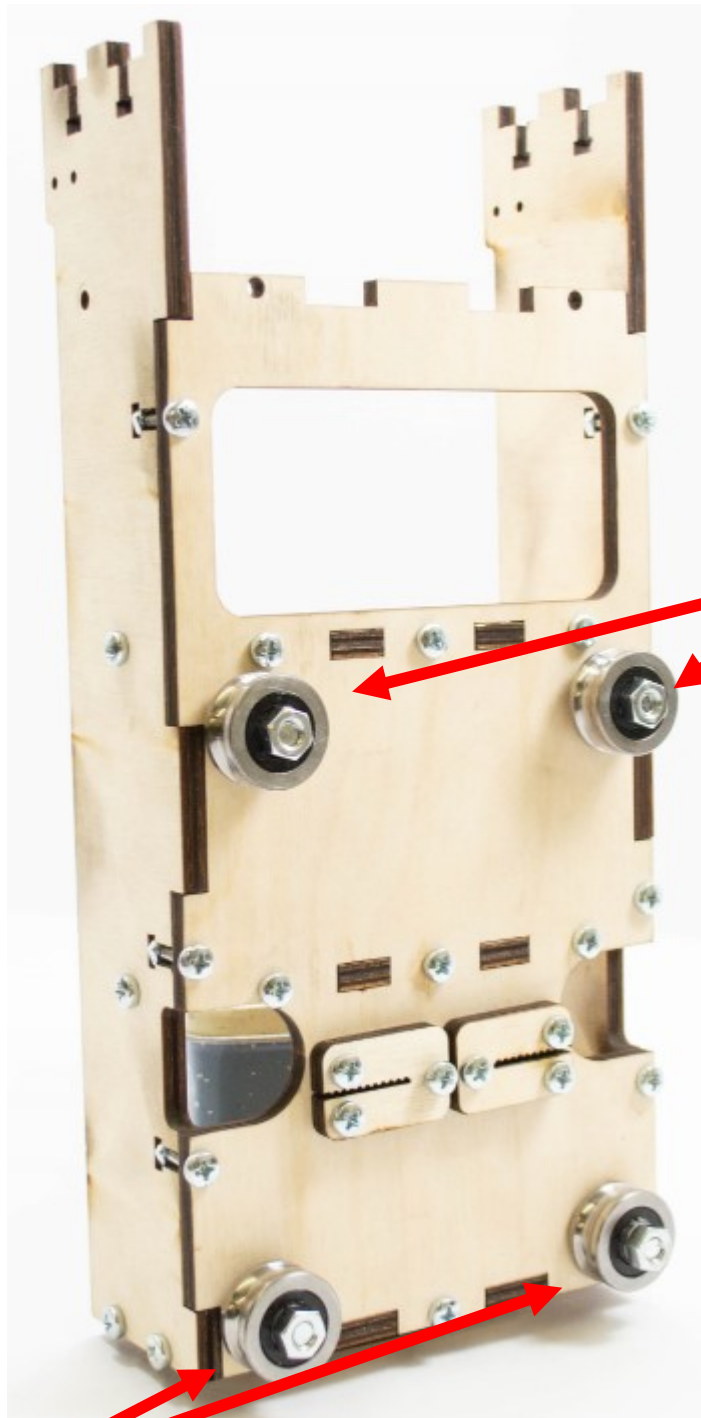

The Bearings in the round holes (on top) must be tight.

Bearings in the elongated holes should be snug and then rotate 1/4 turn.

**Step 9** Gently insert the two 7 1/8" x 5/16" rods through the Z Rail Supports and into holes in the Y Carriage Bottom Support. Rotate the rails through the Z Rail supports. Do not "snap" them into place.

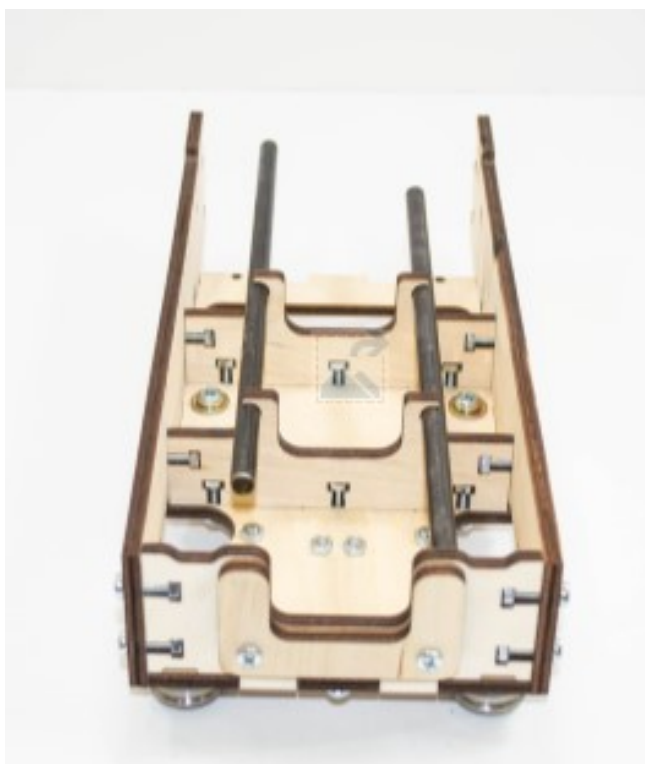
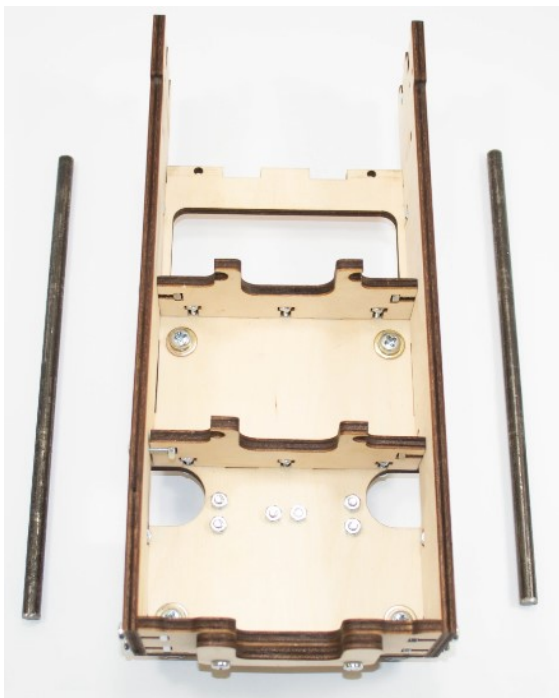

## Step 10

Attach Z-Drive to Y Carriage. Slide Z-Assembly Bearings over the Z-Rails.

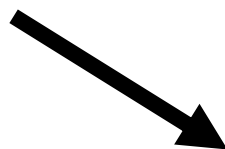
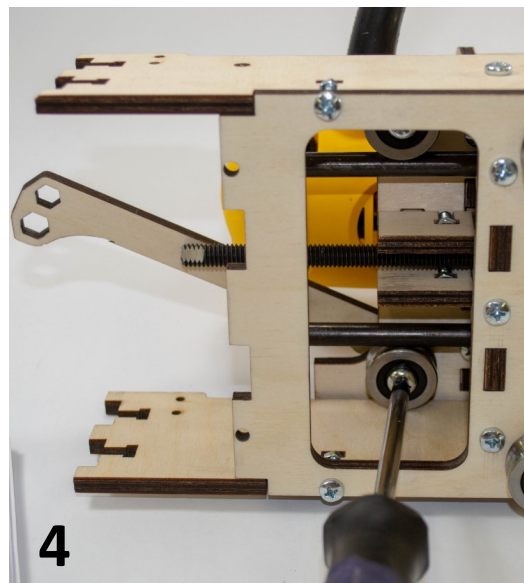
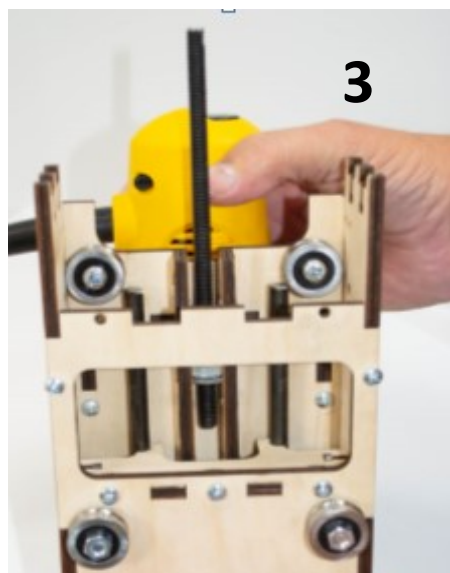
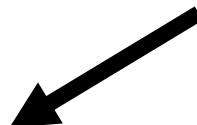
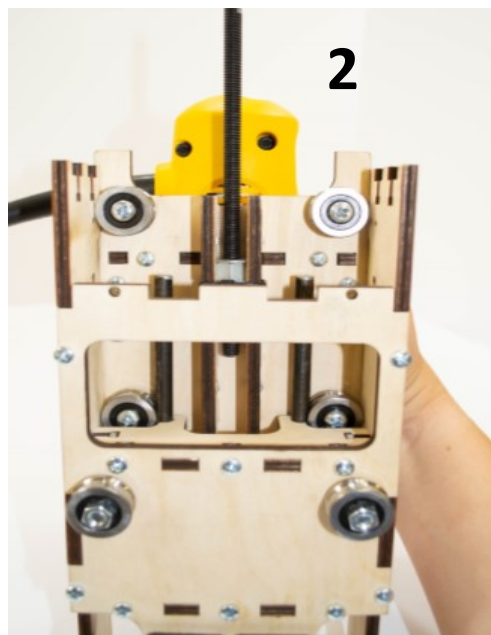
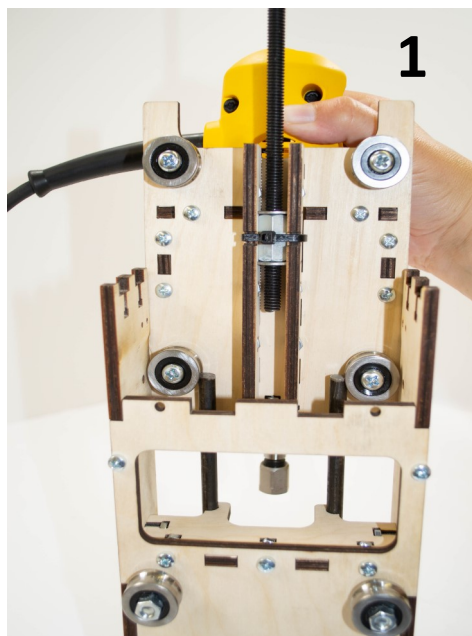

**DO NOT FORCE!** The SG20U Bearings should roll firmly. There should be a small amount of preload. If the Z Assembly doesn't gently slide onto the rails or if the assembly sets loosely on the rails:

- Remove the Z-Assembly from the rails.
- Loosen the 2 nuts on the slotted holes and slide the bearings inward.
- Snug the bearing nuts.
- Repeat Step 11 above

Check all four bearings to ensure that they are snug up against the rail.



## Step 11

**Slide Bearing Bottom Plate over the Threaded Rod setting tabs in slots.**

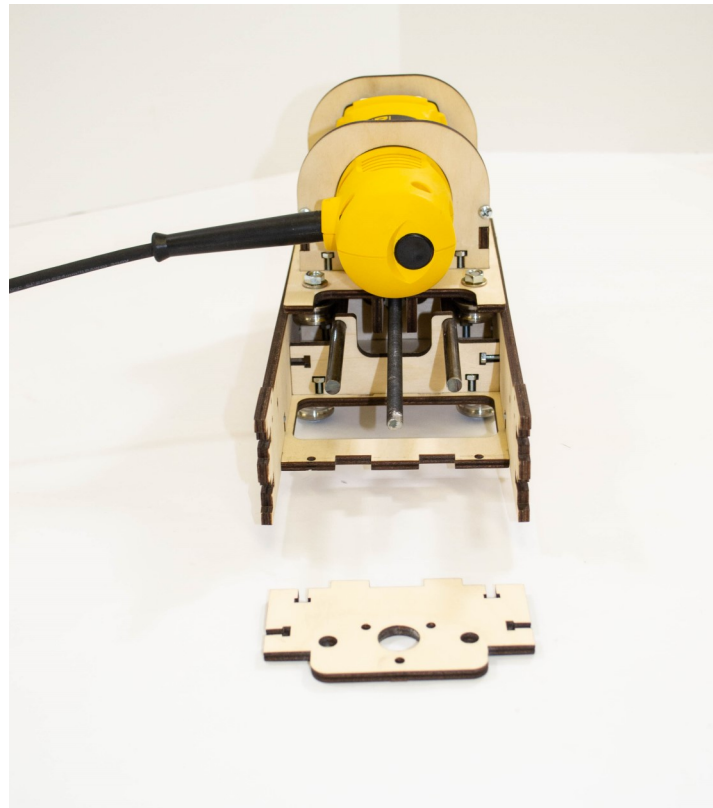

## Step 12

**Attach the Bearing Bottom Plate and secure with four M4 x 16 Screws and Nuts.**

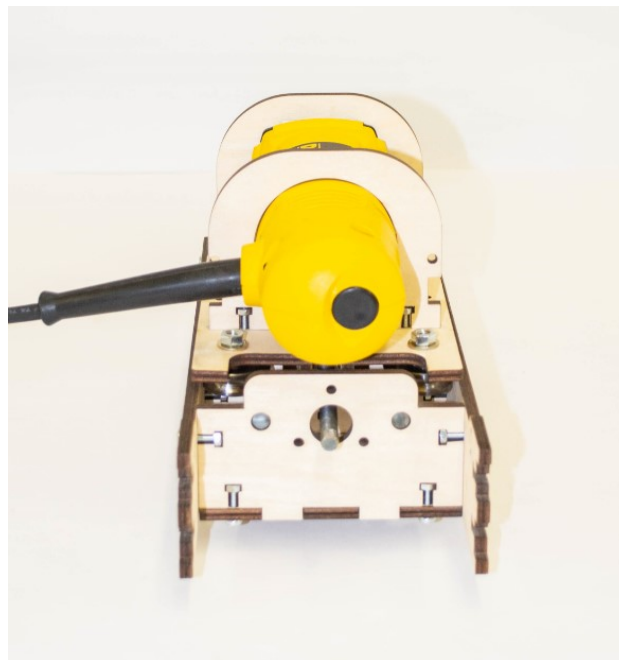

## Step 13 Attach 5/16 Nuts and Bearing on Threaded Z-Rod

As the Router travels up and down the Z Axis make sure the Threaded Z-Rod remains center in the hole.

If necessary adjust to center the rod.

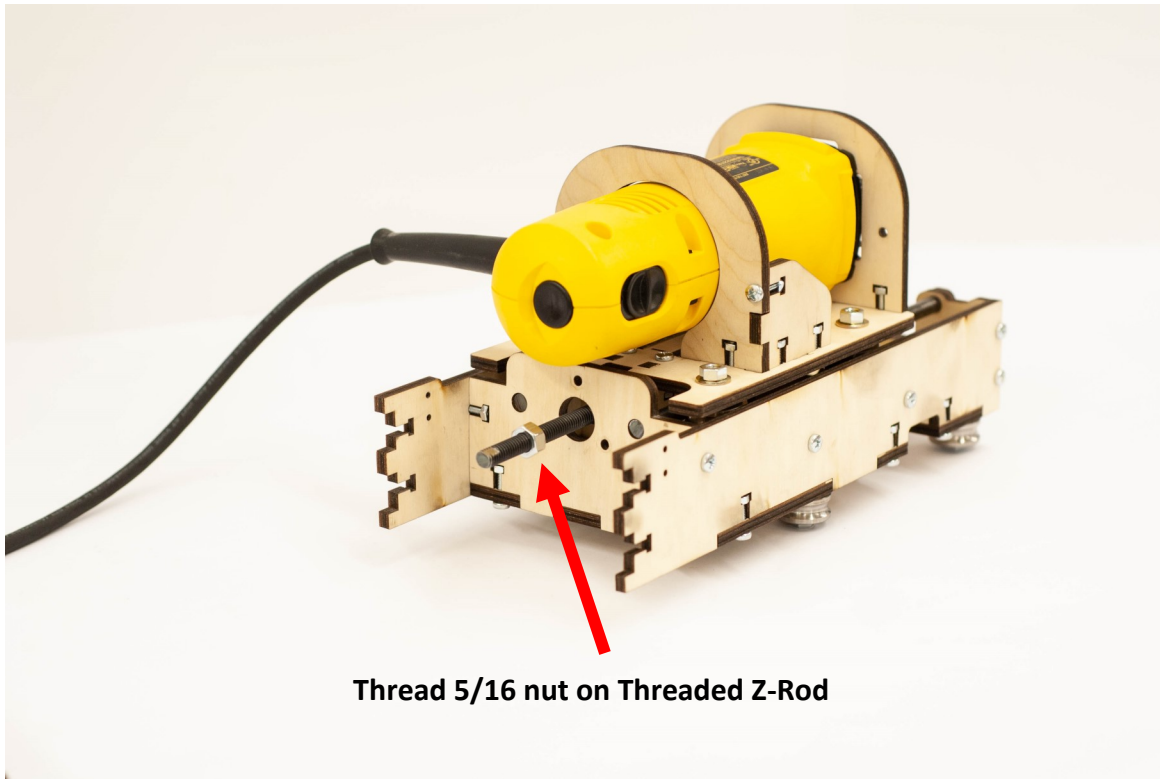
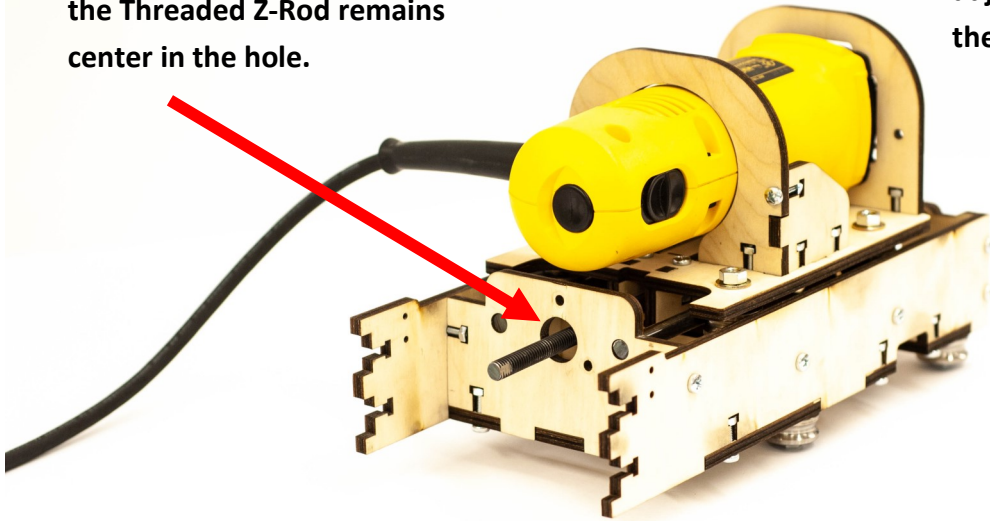

Thread 5/16 nut on Threaded Z-Rod

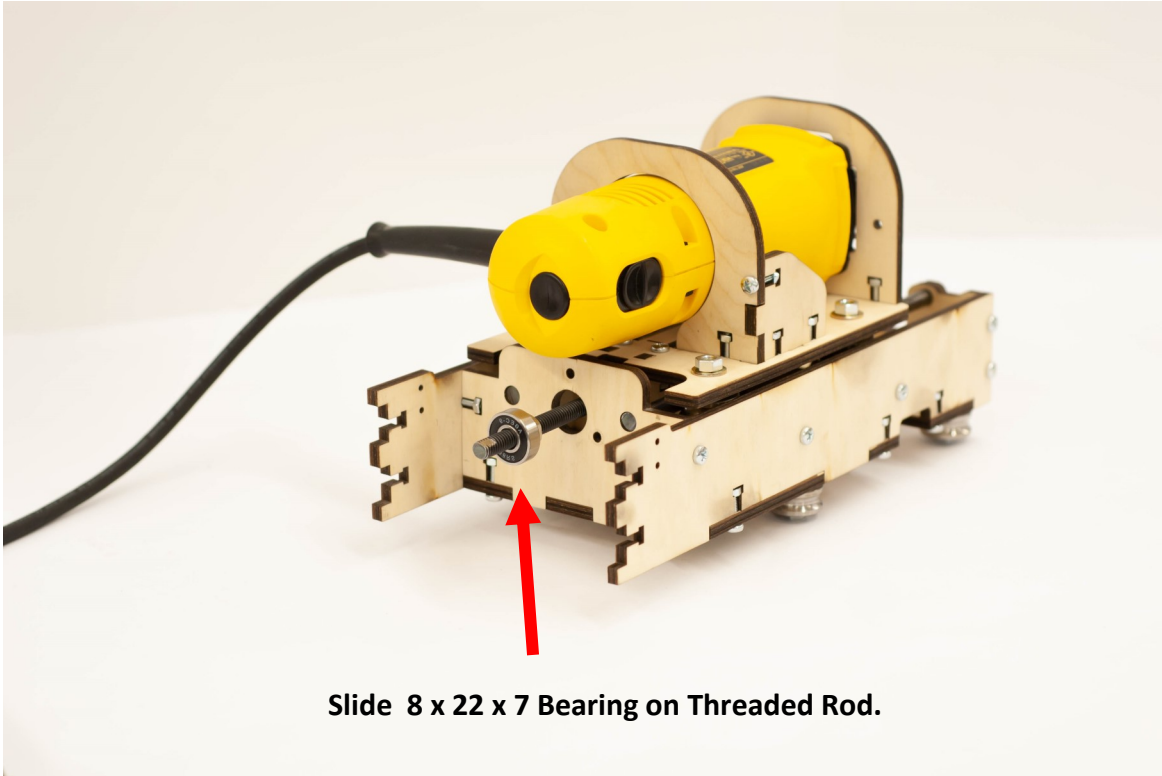

**Slide 8 x 22 x 7 Bearing on Threaded Rod.**

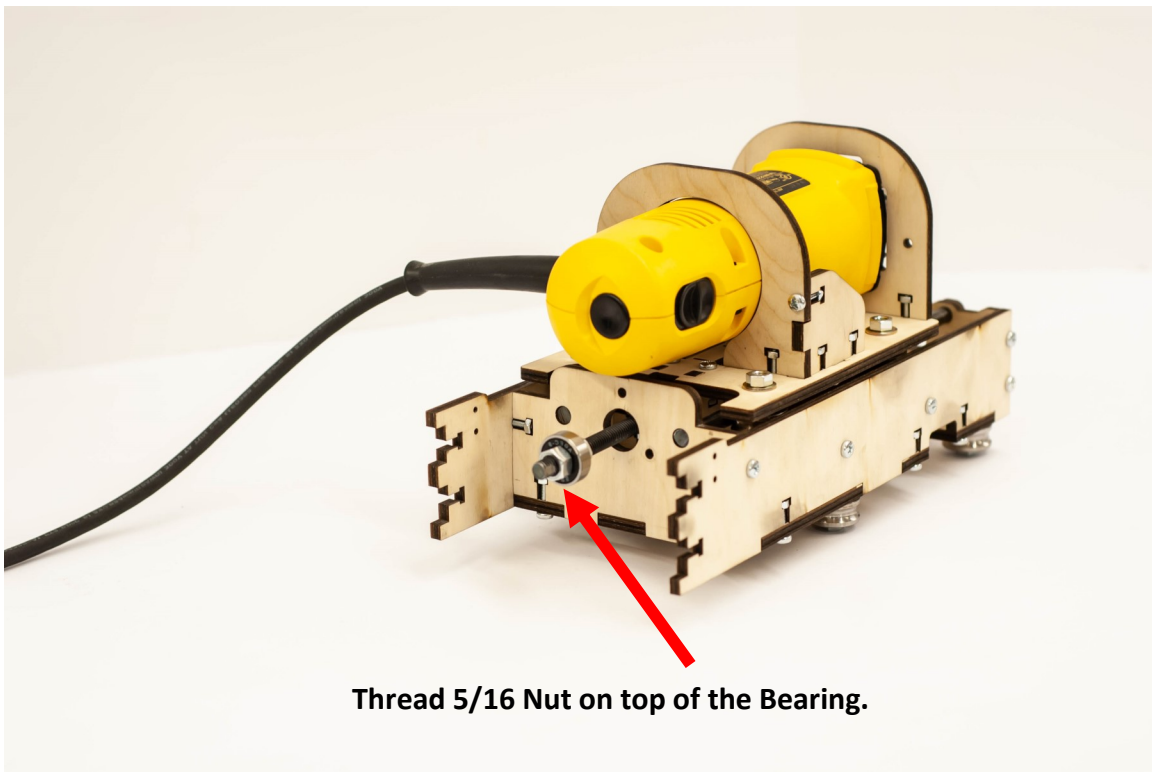

**Thread 5/16 Nut on top of the Bearing.**



The 5/16 Nut on top of the bearing should be turned approximately 6 threads down from end of the Z-Rod. The bearing should be tightened firmly against the upper nut while maintaining the six thread spacing from the end of the threaded rod.

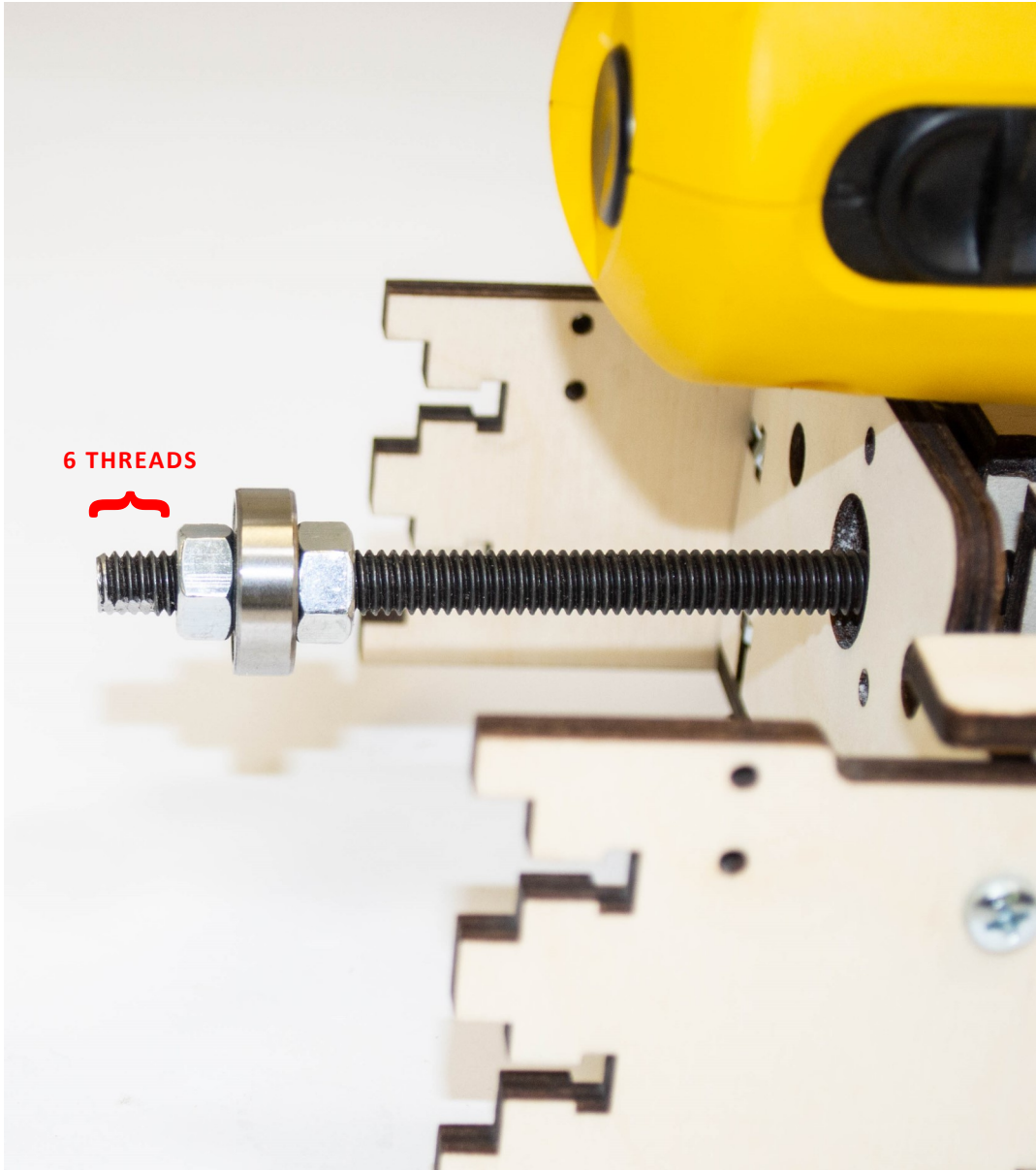



## Step 14

Secure Bearing with Bottom, Middle, and Top Bearing Plates.

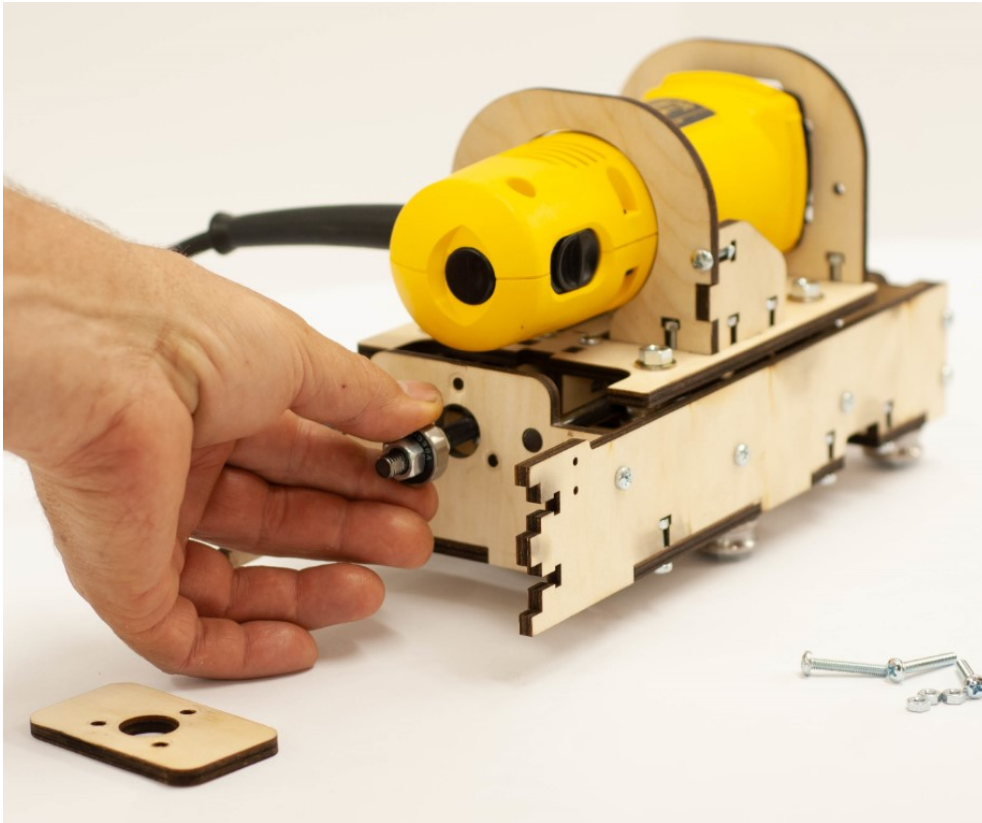

Slide Z-Spindle Mount down rails until nut and bearing assembly rests on Bearing Bottom Mount.

Slide Middle Bearing Plate over the Threaded Rod and Bearing.

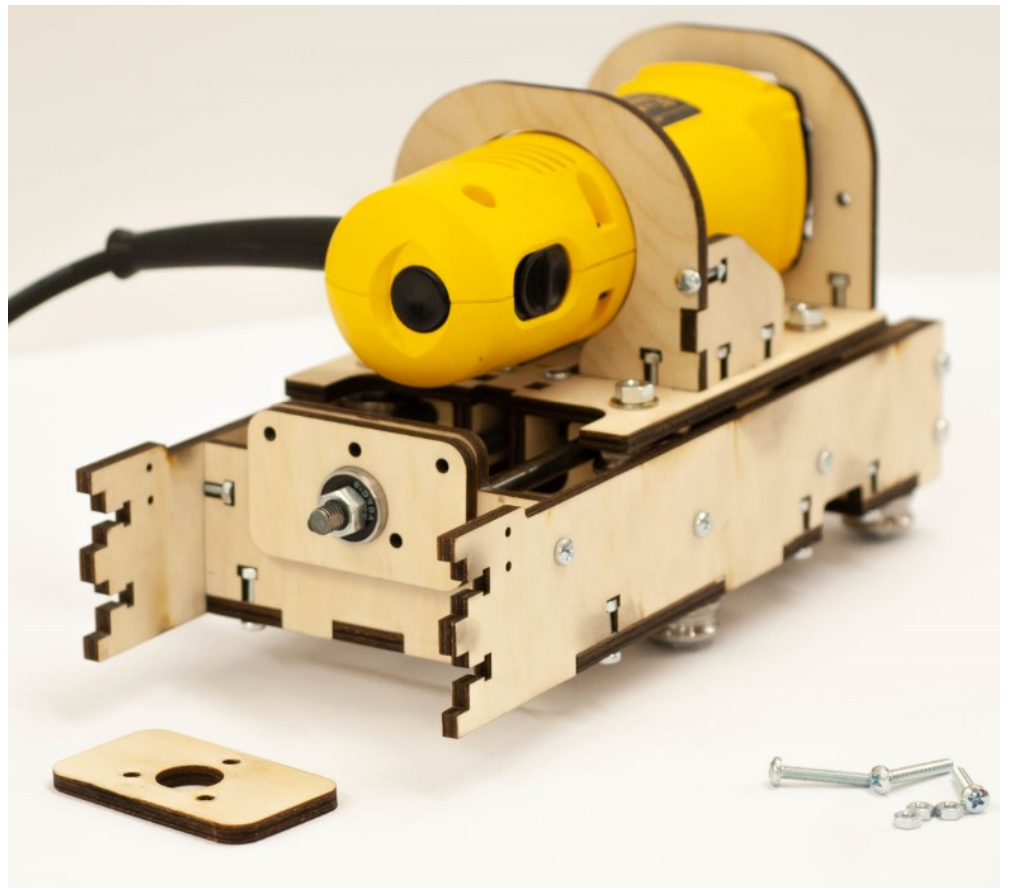

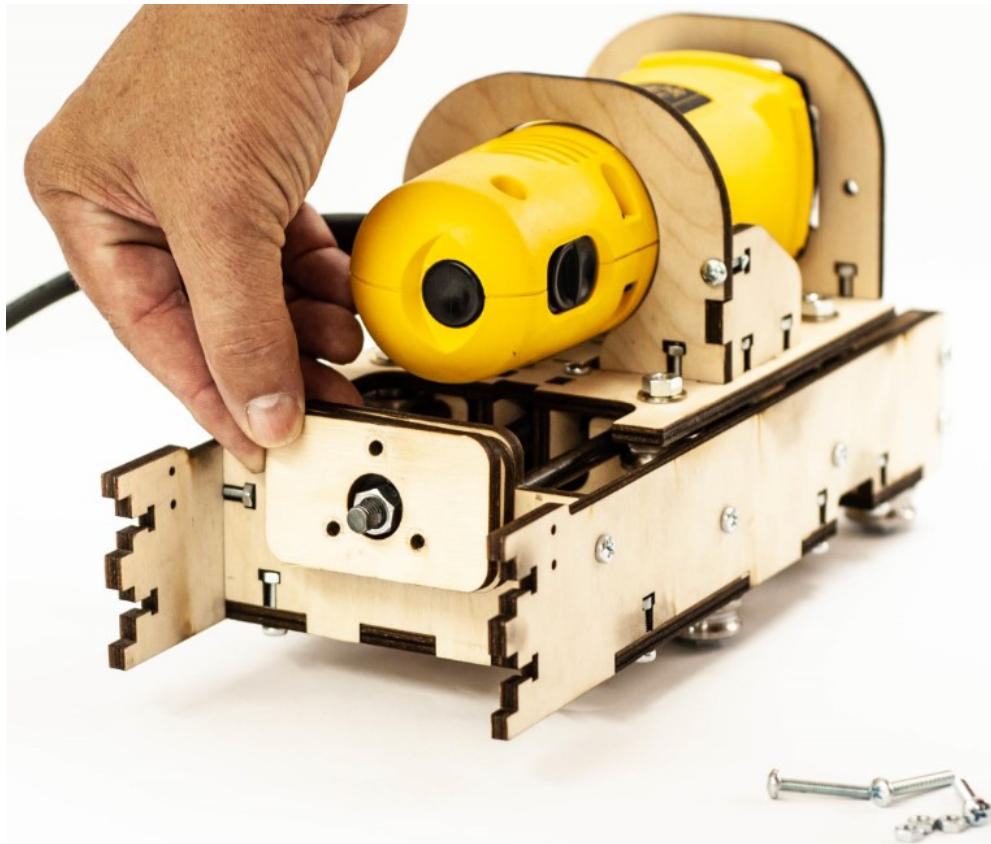

Slide Top Bearing Plate over the Threaded Rod and Bearing and secure with three M4 x 25 Screws and M4 Nuts.

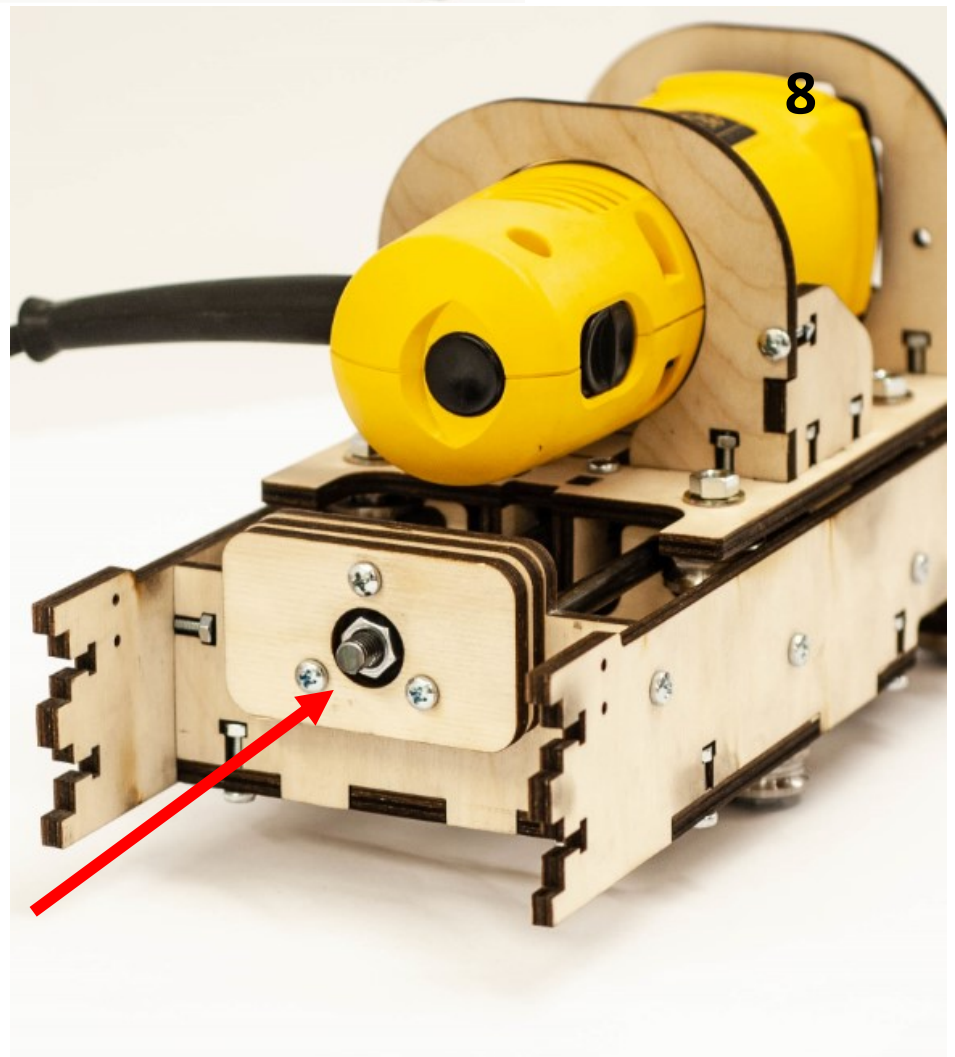

In order to properly retain the bearing securely, evenly tighten screws and nuts in a rotating pattern so that the plywood components are compressed uniformly and tightly together.

## Step 15

Attach Stepper Motor to the Stepper Motor Mount and secure with four M3 x 10 screws.



Apply LOCTITE to all screws.

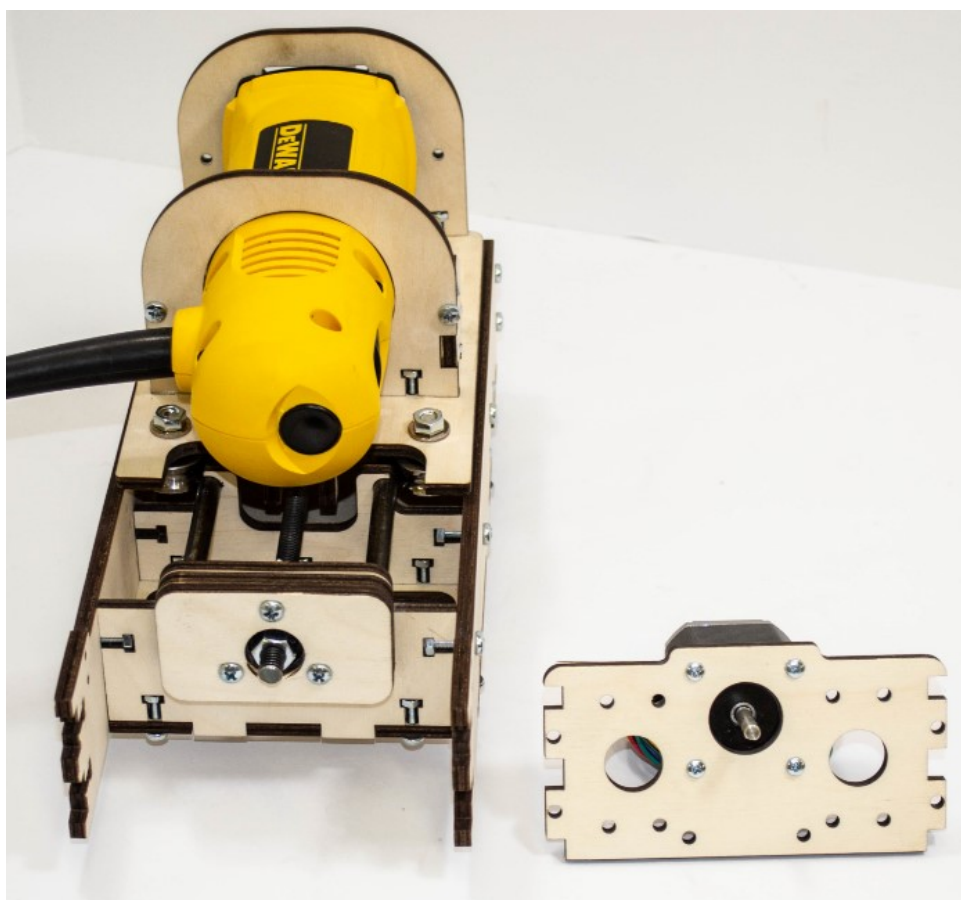
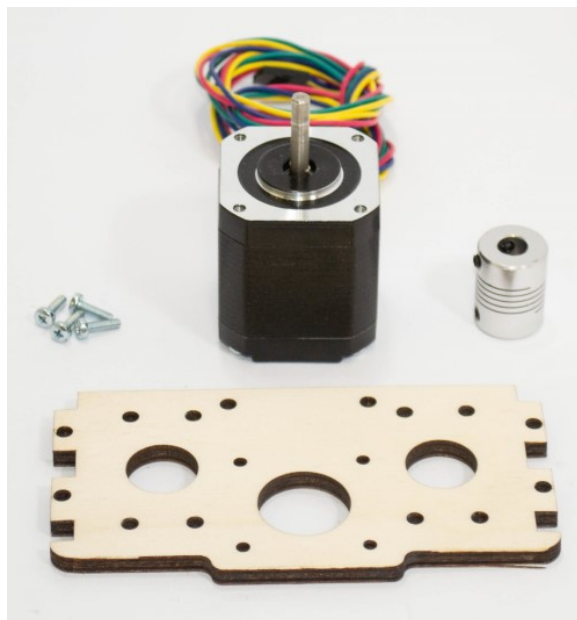



## Step 16

### Attach Helical Coupler to Stepper Motor shaft and Threaded Z-Axis Rod

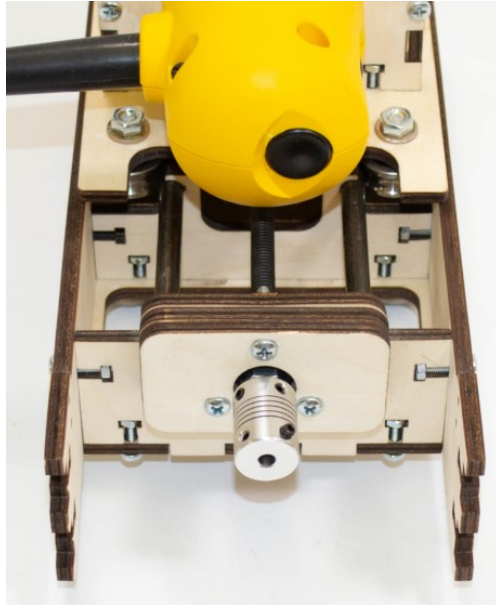

Align the milled flat spot on the end of the Threaded Z-Rod so that the set screw will be tightened directly against the flat spot.

Tighten both set screws with a 2mm Allen Wrench.

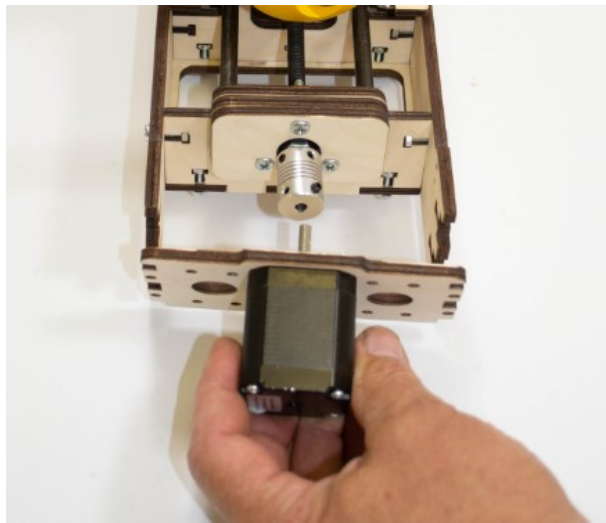

Set the Stepper Motor Mount in place. Align the flat spot on the motor shaft with the set screw of the Helical Coupler and tighten securely.

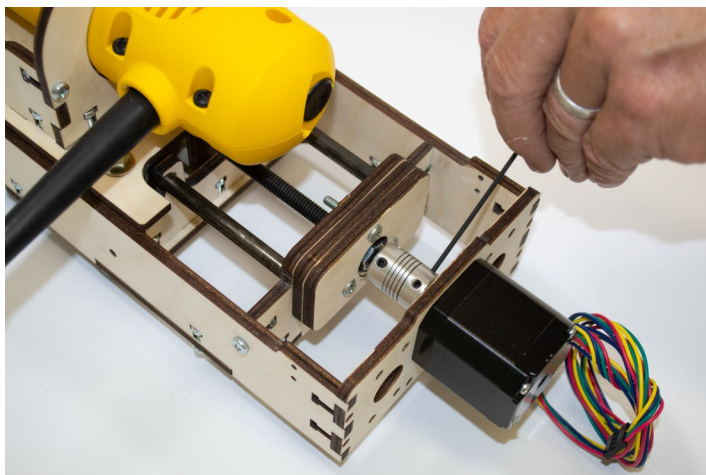



**Secure Stepper Motor Mount with four M4 x 16 Screws and Nuts.**

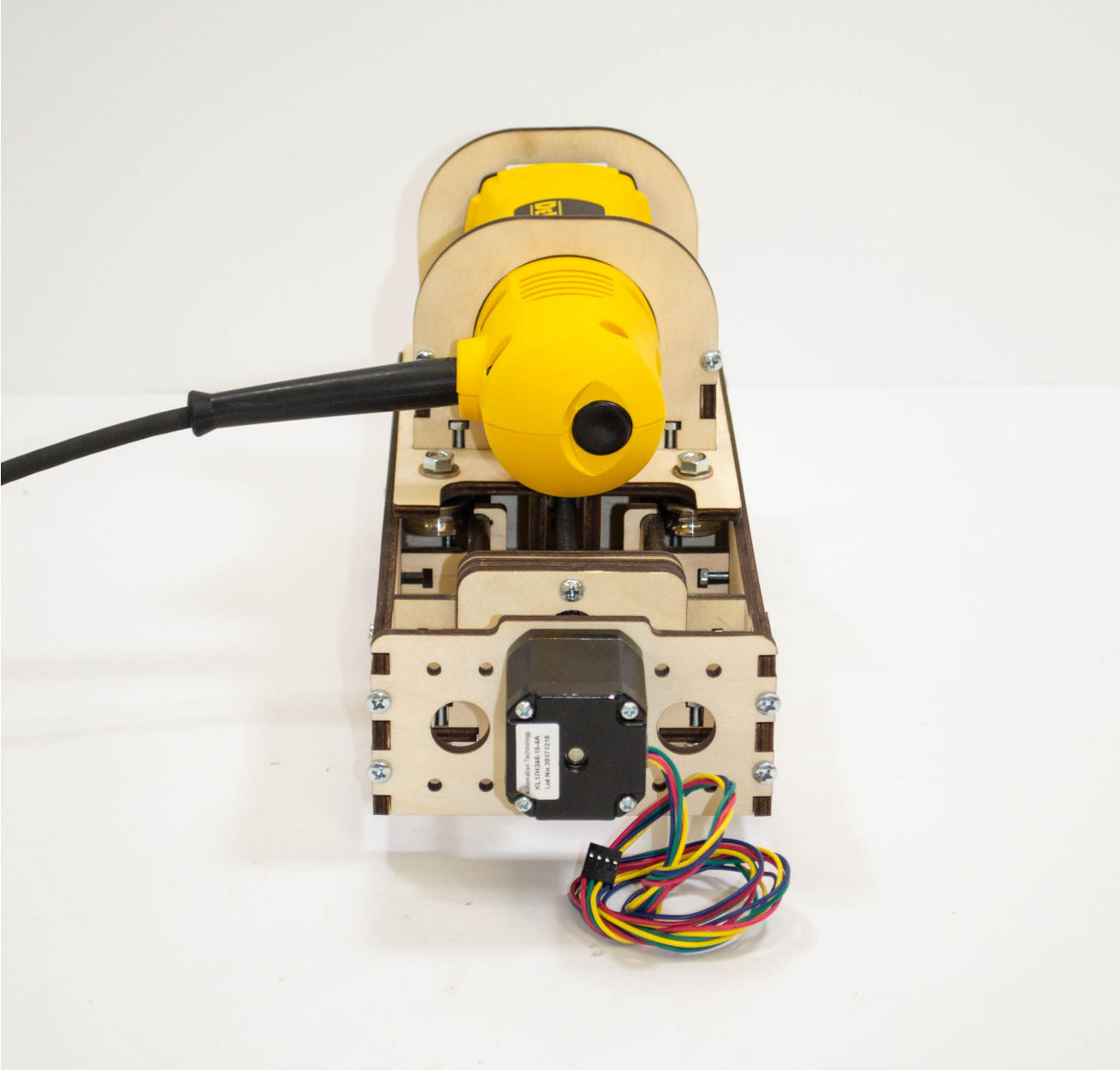

# Frame Assembly Instructions

## X Frame Assembly & Hardware

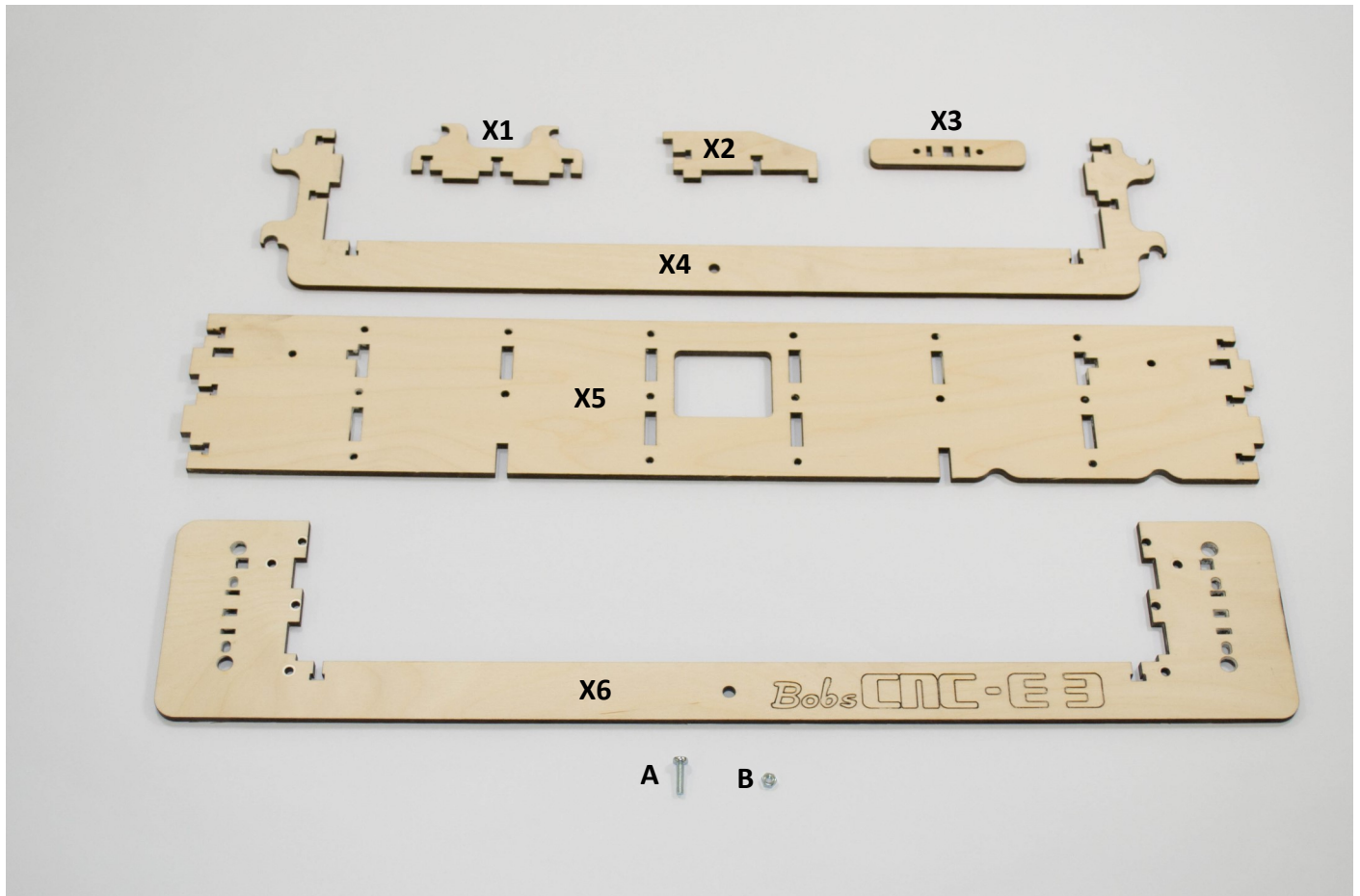

| Part # | Qty | Component          |
|--------|-----|--------------------|
| X1     | 8   | X Rail Support     |
| X2     | 4   | Frame Corner Brace |
| X3     | 4   | X Rail Stop        |
| X4     | 2   | Frame Mid Support  |
| X5     | 2   | Frame Side Support |
| X6     | 2   | Frame End Support  |

| Part # | Qty | Hardware Description |
|--------|-----|----------------------|
| A      | 52  | M4 x 16 Screws       |
| B      | 52  | M4 Nuts              |

## Step 1

Place the four X Rail Supports onto the Frame Side Support and secure each with three M4 x 16 Screws and Nuts.



## Step 2

Repeat procedure with the remaining four X Rail Supports and second Frame Side Support and secure each with three M4 x 16 screws and nuts.



**The Assembled Frames will mirror each other.**



## Step 2

Place both Frame Side Assemblies onto the two Frame Mid Supports and secure with four M4 x 16 screws and nuts.

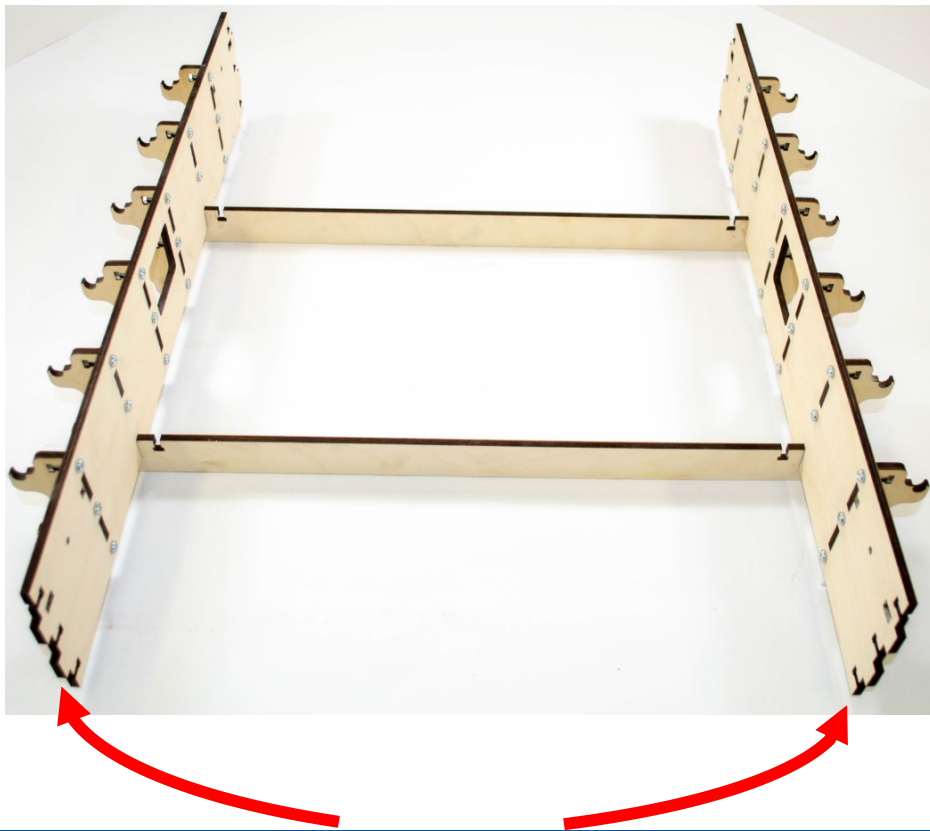

The Frame Side Rails will have the same orientation as shown.



## Step 3

Place the four Frame Corner Brace tabs into the corresponding slots as shown and Secure with one M4 X 16 Screw and Nut.



## Step 4

Attach both Frame End Supports and secure each with eight M4 x 16 Screws.



The four X3 Rail Stops will be used in a latter step.

# Gantry Assembly Instructions

## Gantry Wood Components & Hardware

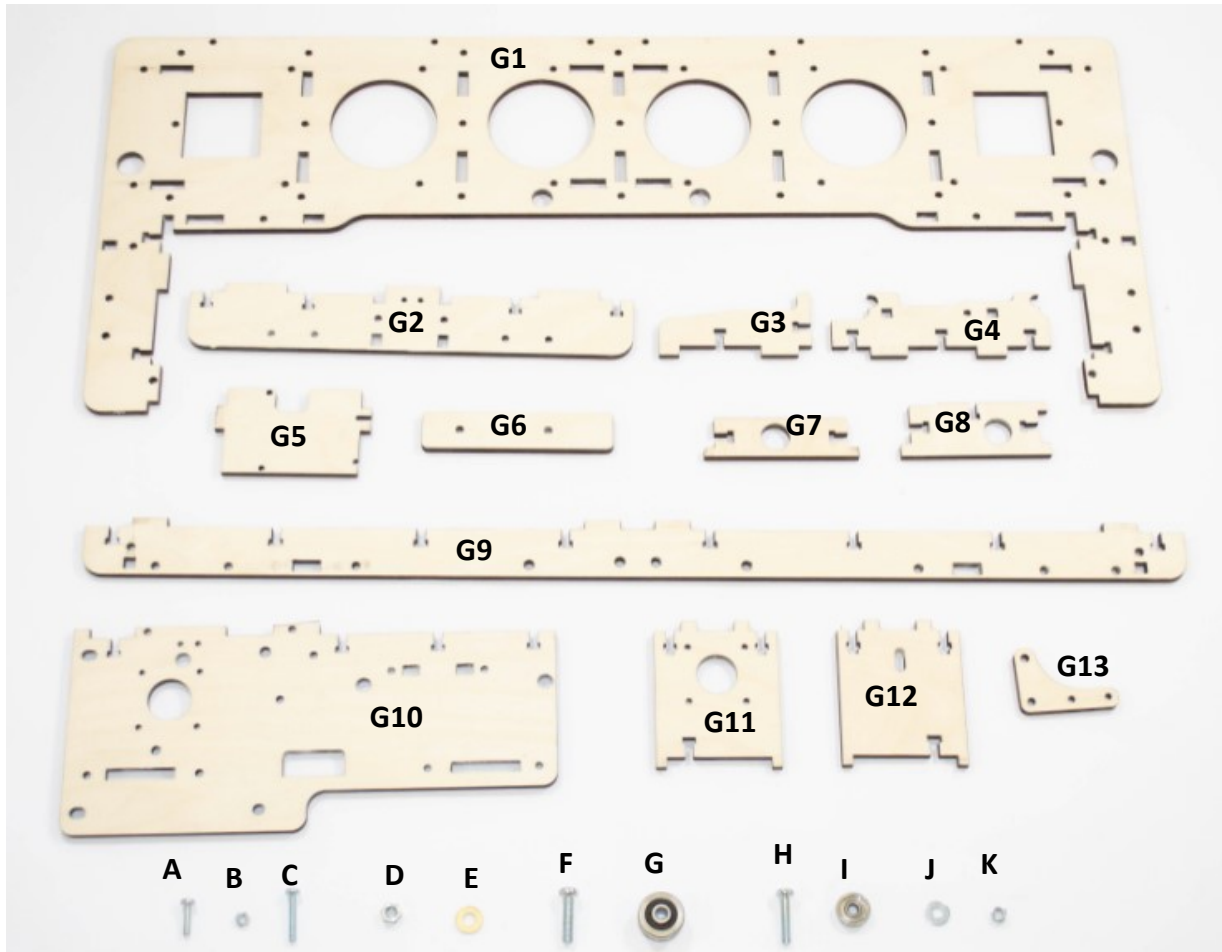

| Part # | Qty | Description           |
|--------|-----|-----------------------|
| G1     | 1   | Gantry Frame          |
| G2     | 2   | Gantry Side Support   |
| G3     | 2   | Gantry Corner Brace   |
| G4     | 5   | Y Rail Supports       |
| G5     | 1   | Controller Mount      |
| G6     | 2   | Y Rail Stop           |
| G7     | 2   | Gantry Back Brace     |
| G8     | 2   | Gantry Side Brace     |
| G9     | 2   | Gantry Back Support   |
| G10    | 2   | Gantry Side Frame     |
| G11    | 1   | Y Stepper Motor Mount |
| G12    | 1   | Y Belt Idler Mount    |
| G13    | 2   | Cable Mount           |

| Part # | Qty | Description         |
|--------|-----|---------------------|
| A      | 67  | M4 x 16 Screws      |
| B      | 71  | M4 Nut              |
| C      | 4   | M4 x 25 Screws      |
| D      | 8   | M6 Nuts             |
| E      | 16  | M6 Hardened Washers |
| F      | 8   | M6 x 25 Screws      |
| G      | 8   | SG20U Bearings      |
| H      | 3   | M5 x 25 Screws      |
| I      | 6   | F625 Idler Bearings |
| J      | 6   | M5 Washer           |
| K      | 6   | M5 Nut              |



In order to properly complete the next step all five parts must be assembled before attempting to secure them with M4 x 16 screws and nuts.

## Step 1

Position the Controller Mount, the two Gantry Main Braces and the two Gantry Back Supports and secure with twenty M4 x 16 screws and nuts.

1.1

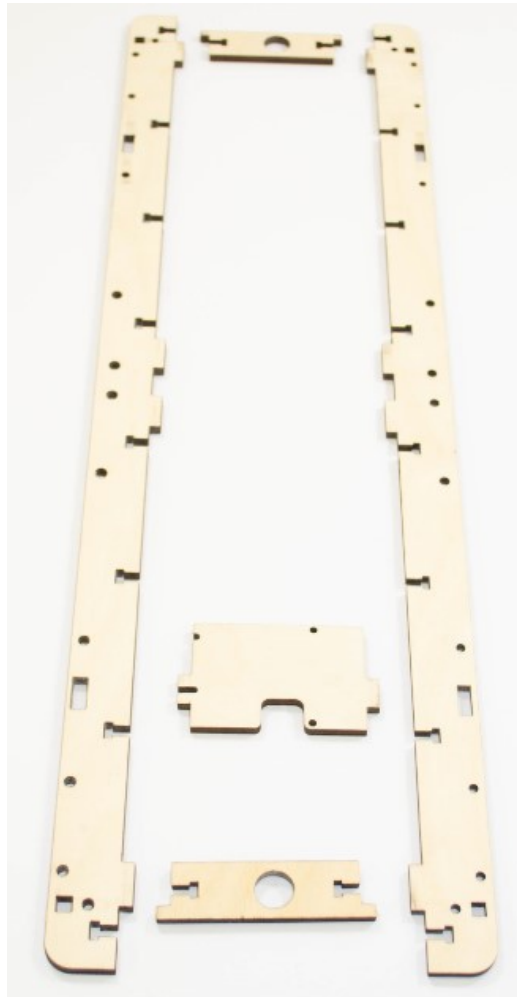

The Controller Mount must be fastened to the left side, the same side as the controller.





**IMPORTANT** Note the orientation of the Controller  
Mount below:

## 1.2



## 1.3

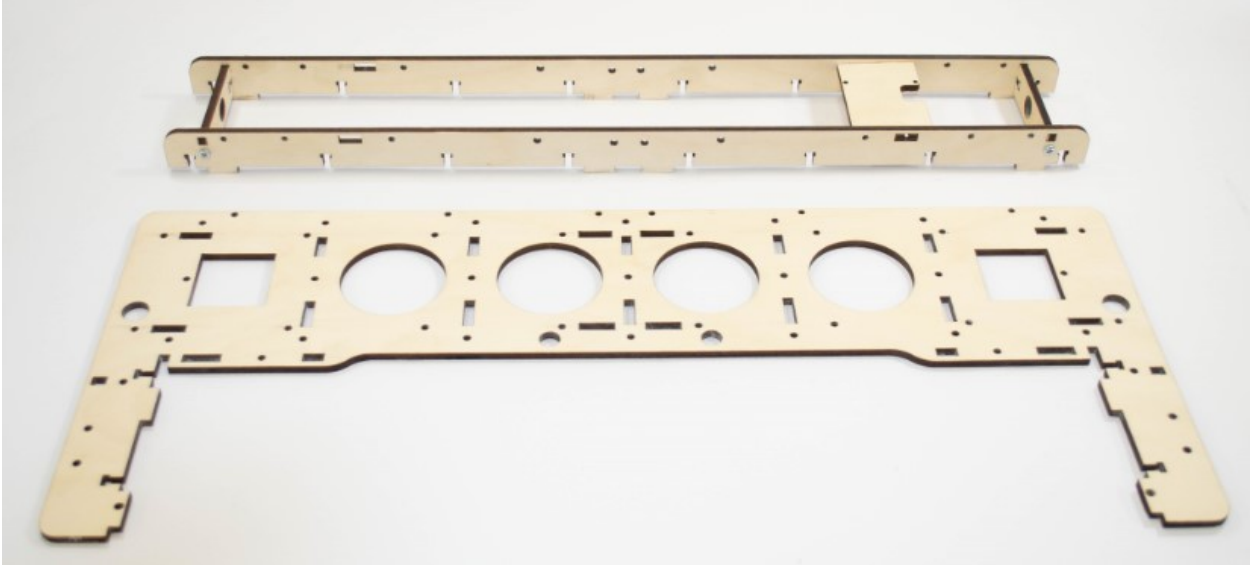

## 1.4

Using slots and tabs, set the **Controller Mount Assembly** on the **Gantry Frame**.



## 1.5

Secure the Controller Mount Assembly to the Gantry Frame using sixteen M4 x 16 screws and nuts.



**IMPORTANT** Note the orientation of the Controller Mount below. Note that the hole in the Gantry Frame is accessible because of the cutout in the Controller Mount. Wide spacing for screw holes must be mounted on top.

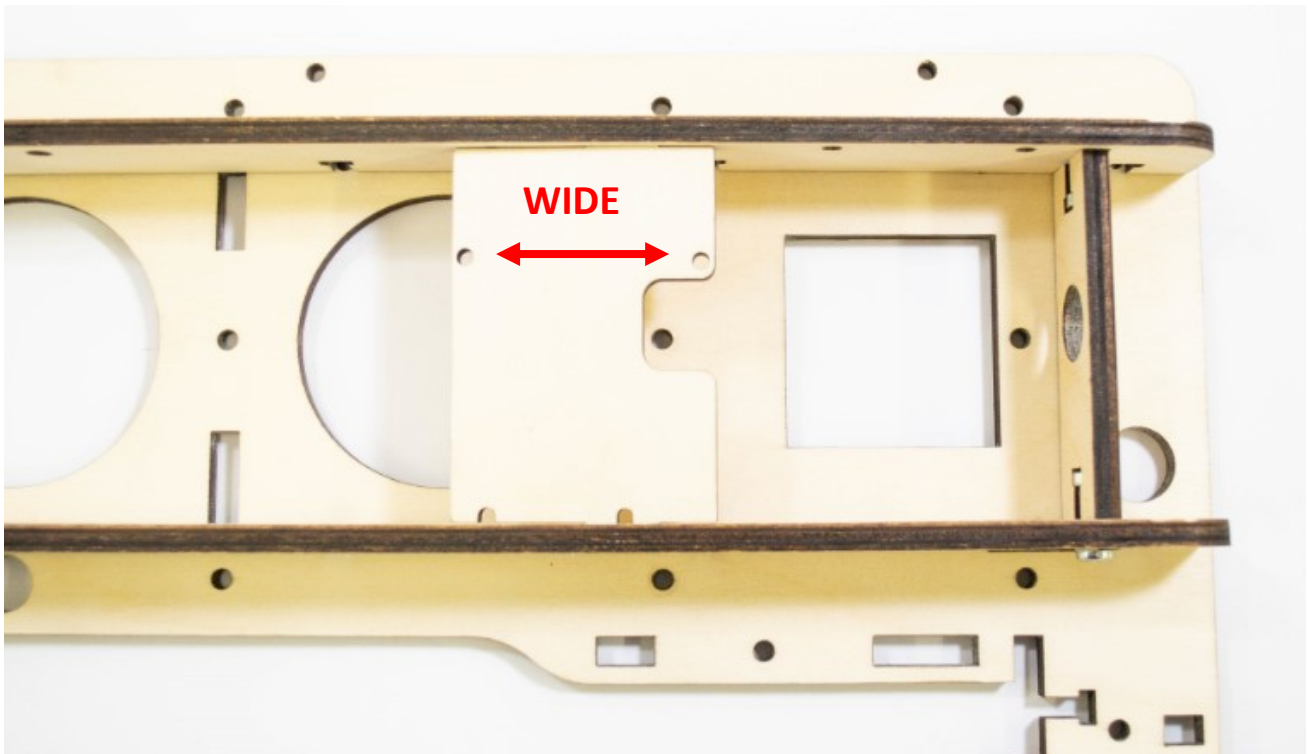

## Step 2

Flip the Gantry Main Frame over and insert the five Y Rail supports to the Gantry Assembly and secure each with three M4 x 16

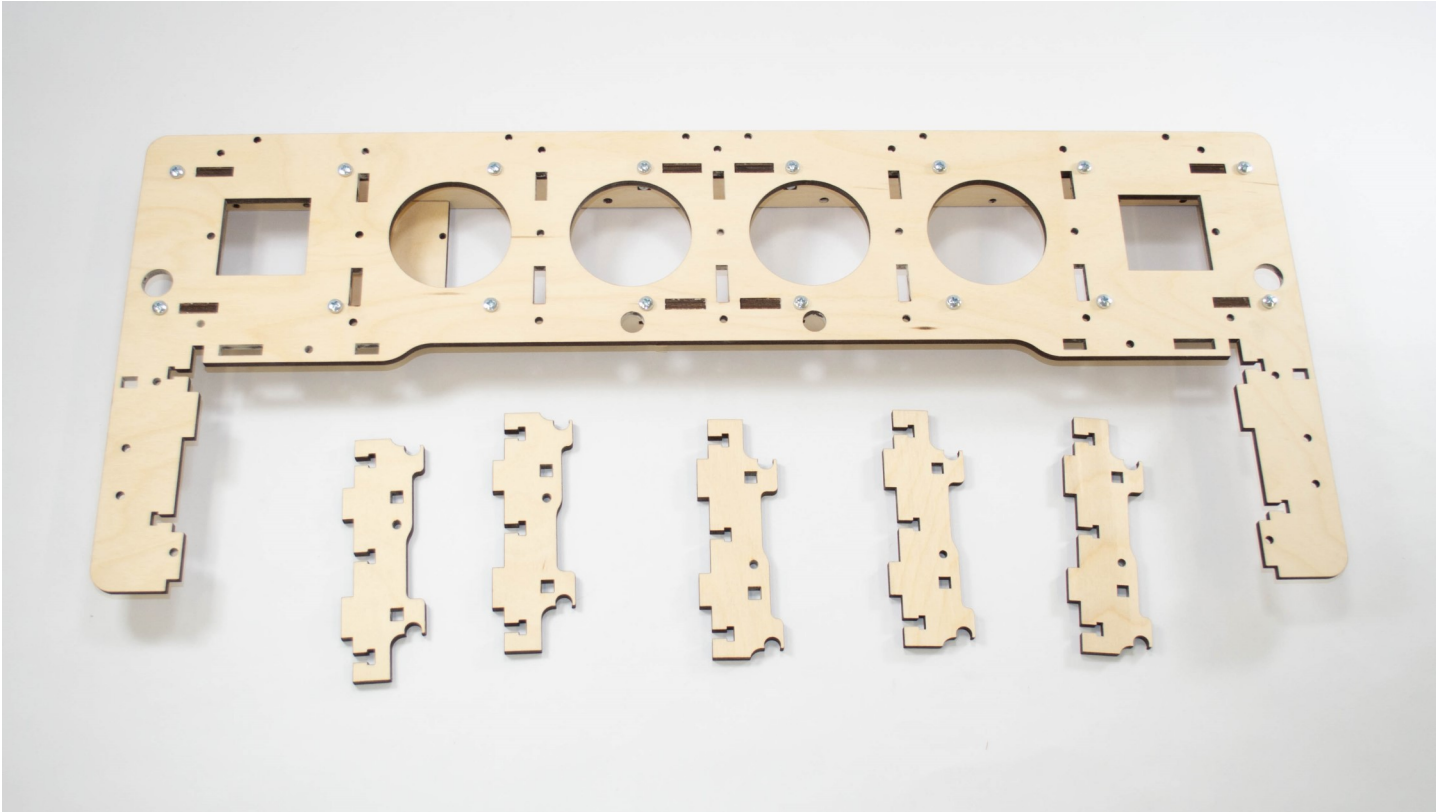





**Step 3.** Attach Y Stepper Motor Mount and secure with a M4 x 16 screws and nuts.

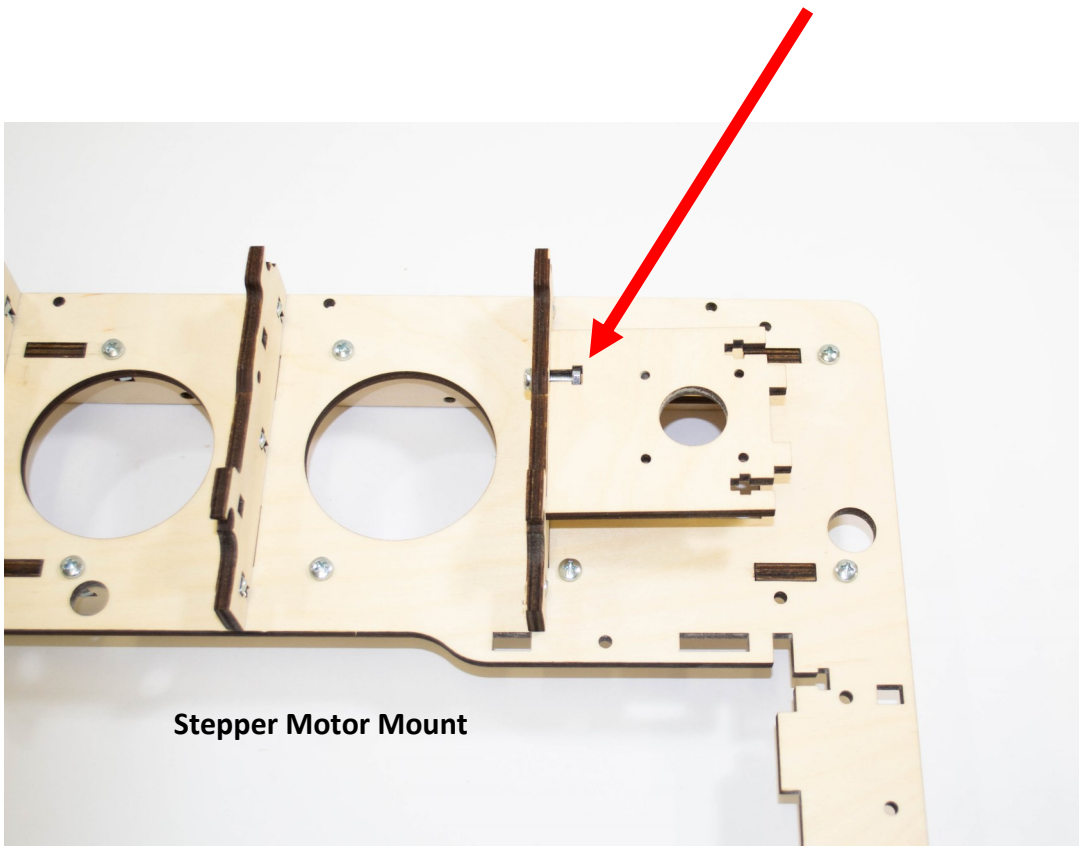

## Step 4

Attach Idler Mount and secure with a M4 x 16 screw and nut.

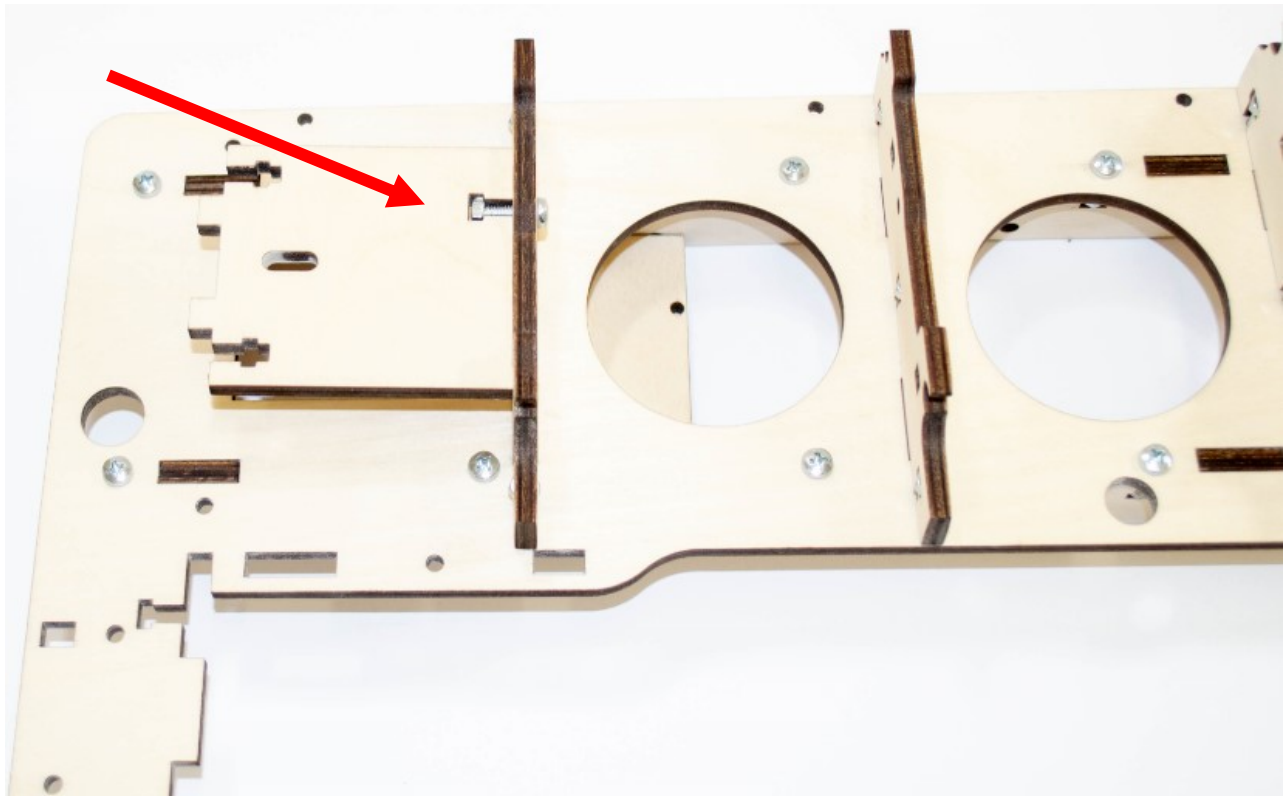

## Step 5

Attach both Gantry Side Frames and secure each with six M4 x 16 screws and nuts (each side).

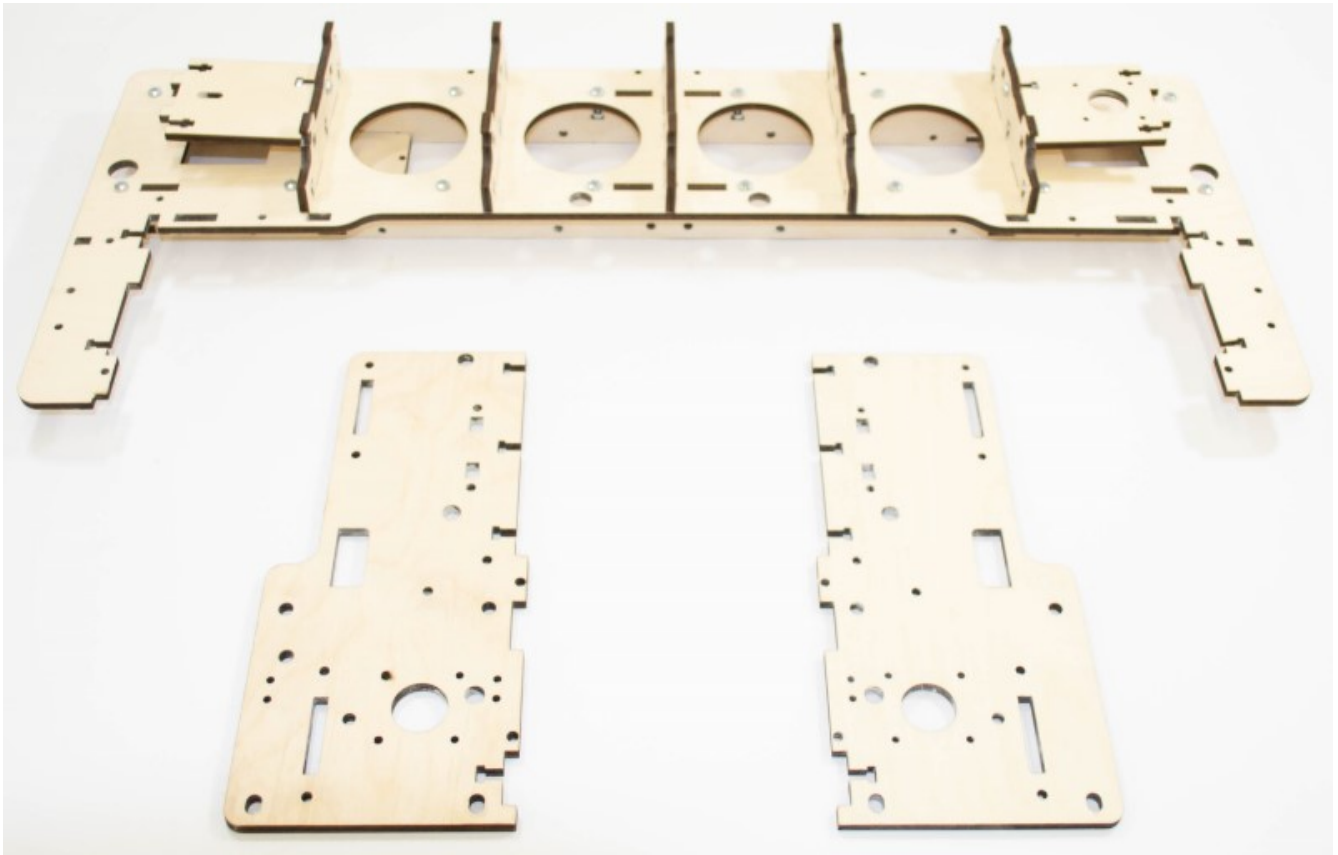

Do not install the two fasteners that connect the Gantry Side Frame at this time. Two M4 x 25 Screws with nuts will be inserted in each piece in a later step:



## Step 6

Attach both Gantry Corner Braces and secure each with two M4 x 16 screws and nuts.

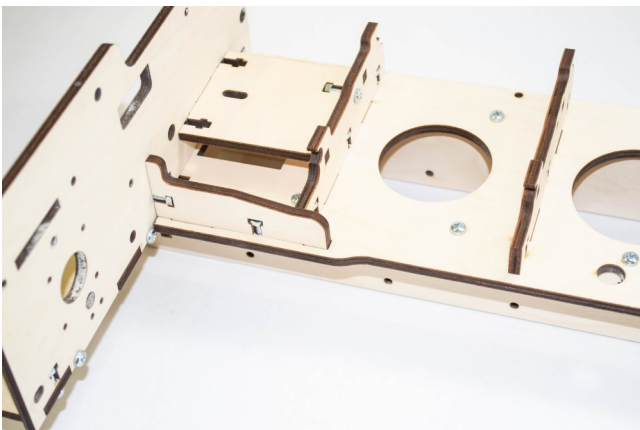
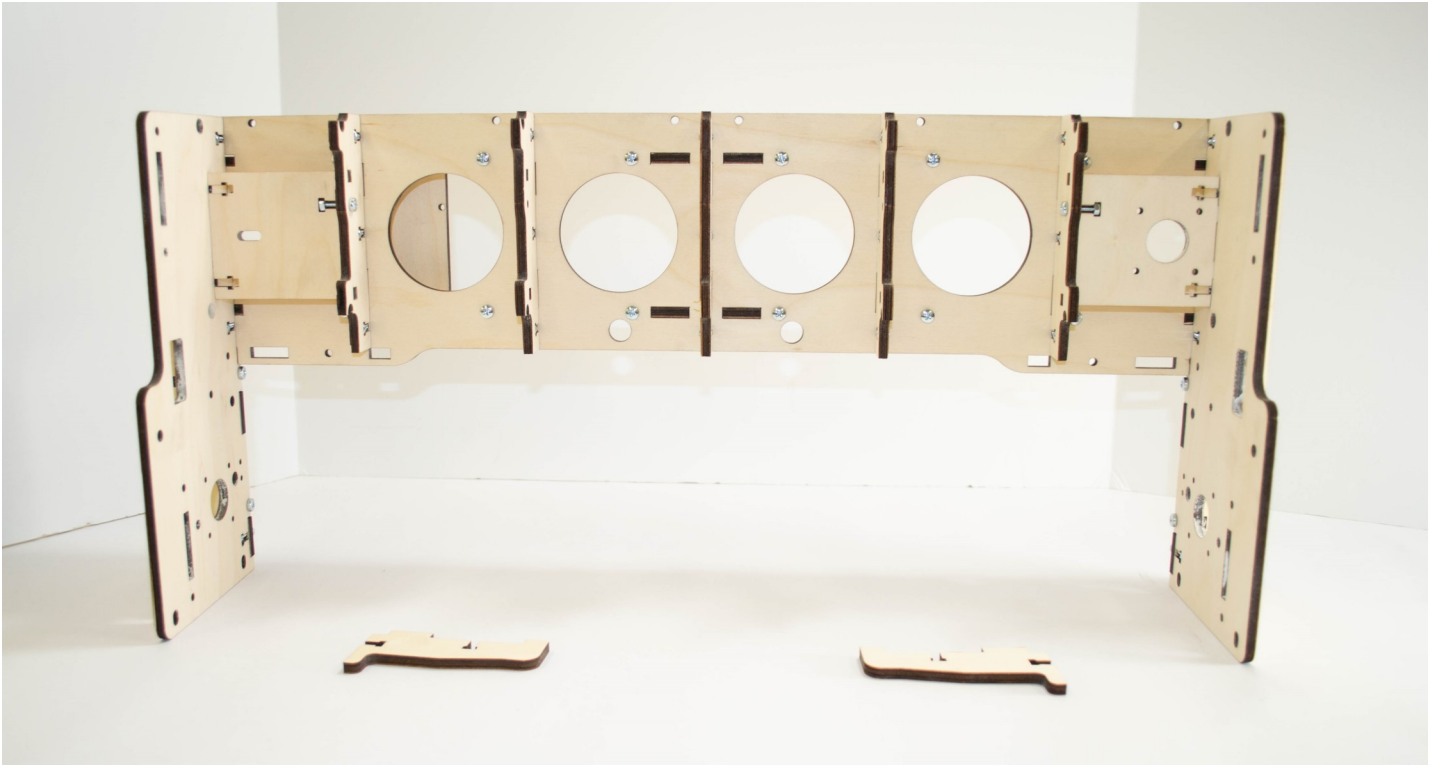



## Step 7

Install four SG20U bearings on the inside of both Gantry Sides Frames. Snug the bearings in the round holes then rotate two to four turns.



Gantry Bearing sequence: Screw head / SG20U Bearing (hub inboard) / Hardened Washer/Plywood / Hardened Washer / Nut

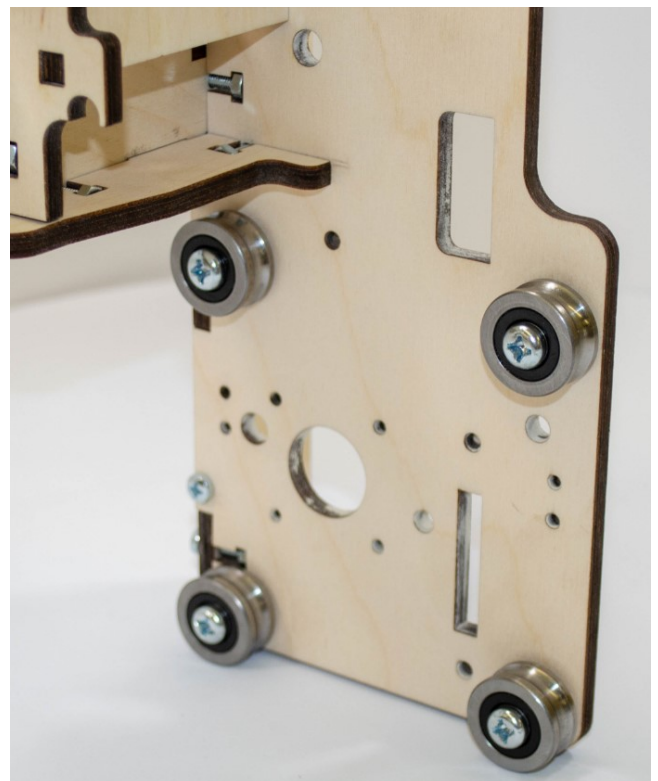

## Step 8

Move the SG20U Bearings in the elongated holes upward and snug the nuts and rotate 1/4 turn. These will be tightened when installed on the Main Frame.

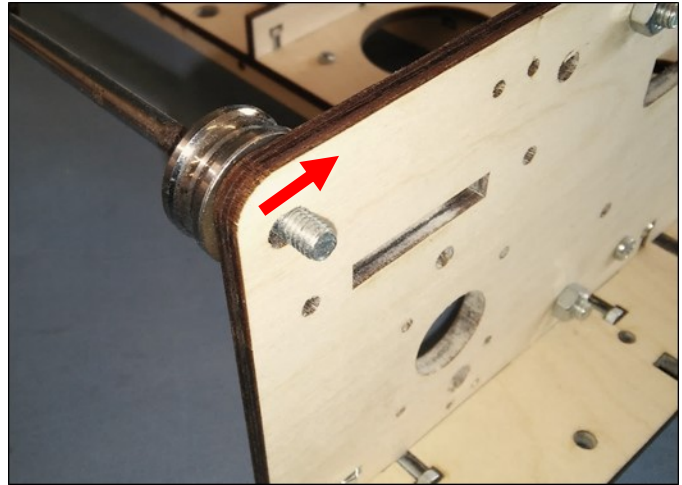

## Step 9

Install three sets of Idler Bearings by inserting a M5 x 25 Screw into the Flanged Bearings (keeping the flanges outboard). Thread a nut on the M5 Screw and tighten (see bolt pattern below):



Flanges must be positioned toward the outside (outboard).

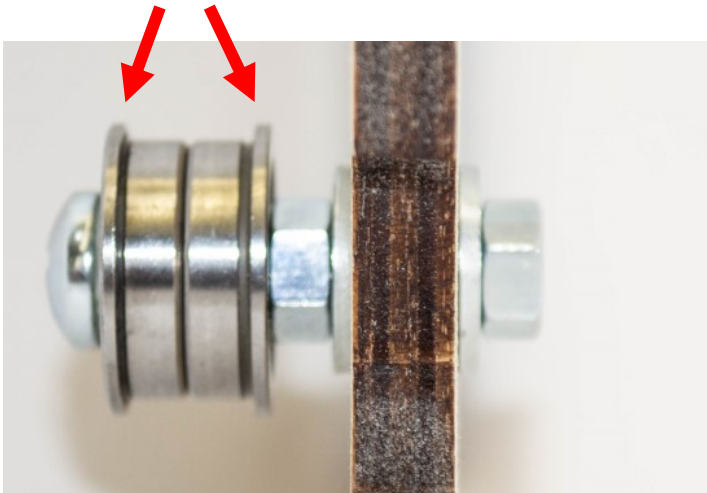

**Left Side**

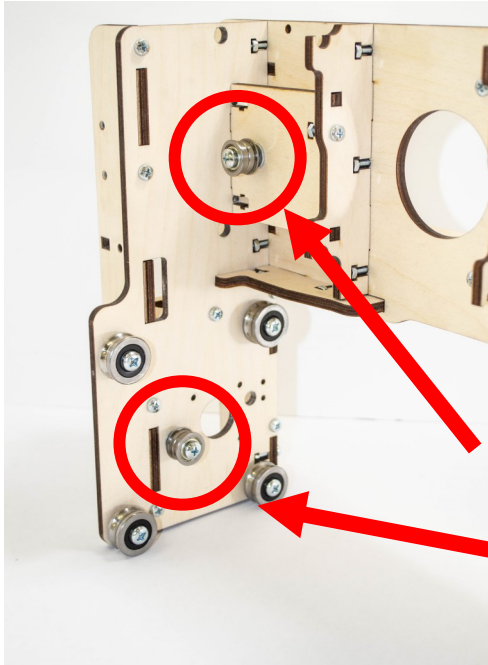

**Right Side**



**Location of  
Idler Bearings**

## **Step 10**

**Add Gantry Side Brace and Side Support and secure with seven M4 x 16 screws and nuts. Repeat for other side.**



**The G13 Cable Mounts will be installed in a later step (p 76).**



# Gantry Assembly and GT2 Pulley Instructions

## Parts Required

| Part # | Qty | Description       |
|--------|-----|-------------------|
| 1      | 1   | Assembled Gantry  |
| 2      | 3   | Stepper Motors    |
| 3      | 2   | Switches          |
| 4      | 1   | Controller        |
| 5      | 2   | 10 Small Zip Ties |
| 6      | 3   | GT2 Pulleys       |
| 7      | 1   | Spiral Wrap       |
| 8      | 4   | M42.5 x 16        |
| 9      | 12  | M3 x 10 Screws    |
| 10     | 4   | M2.5 Nuts         |

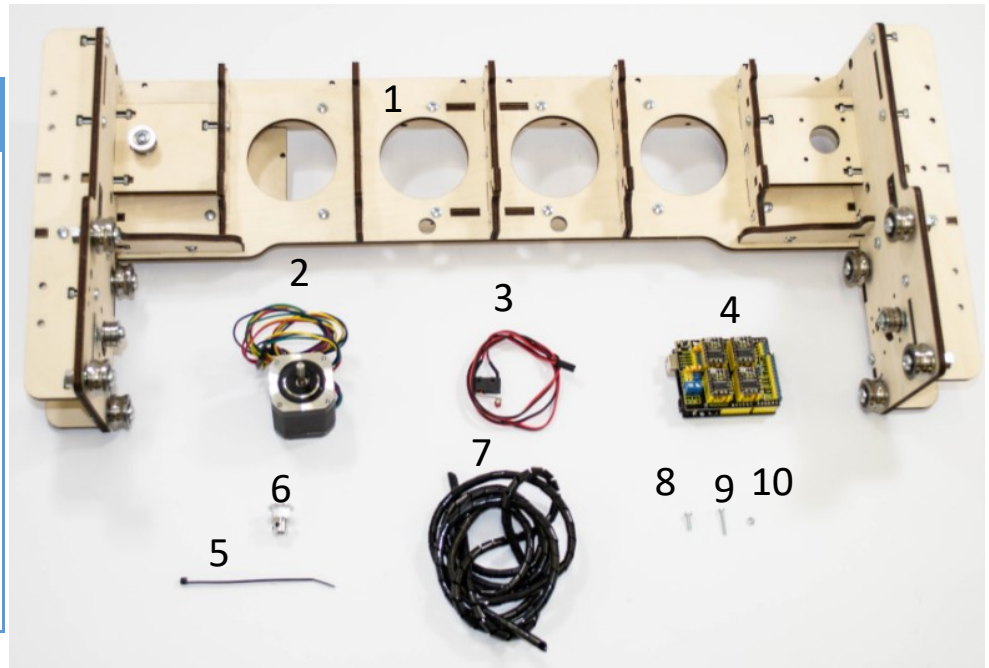

## Step 1

Install each of the three Stepper Motors and secure each with four M3 x 10 Screws.



**X1-Motor**

**Y Motor**

**X2-Motor**

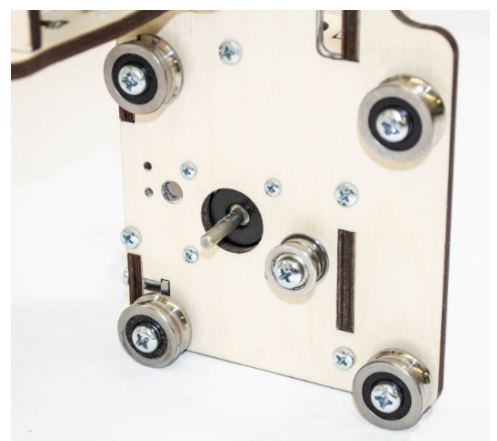
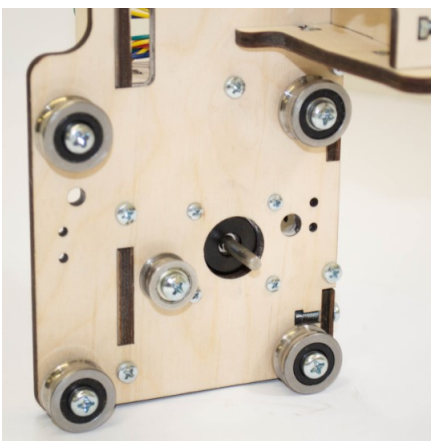



Carefully label each Stepper Motor connector so that the correct electrical connections will be made to the controller (see below):

Stepper Motor mounting viewed from the back side:

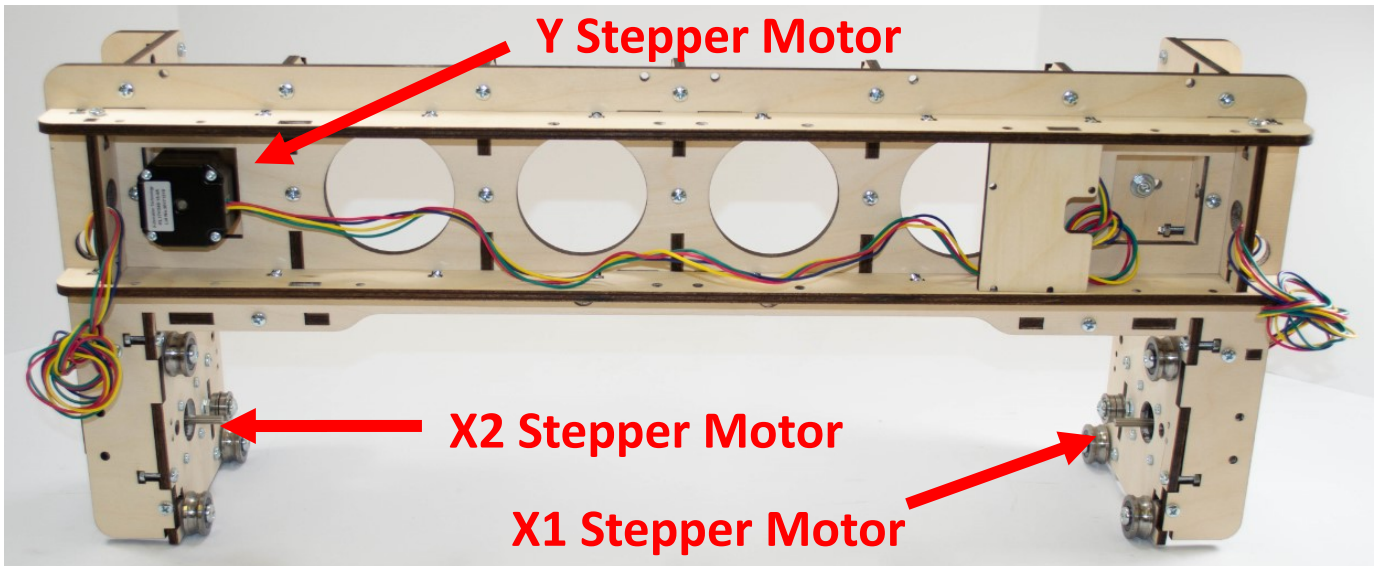

## Step 2

Insert each of the three GT2 Pulleys into position and tighten the set screws.

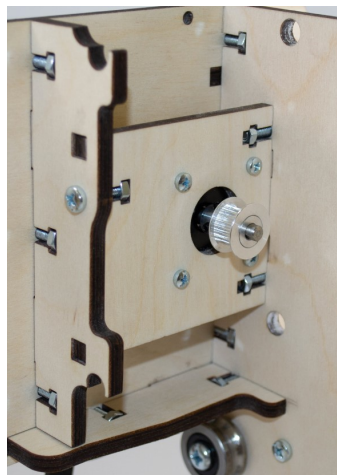
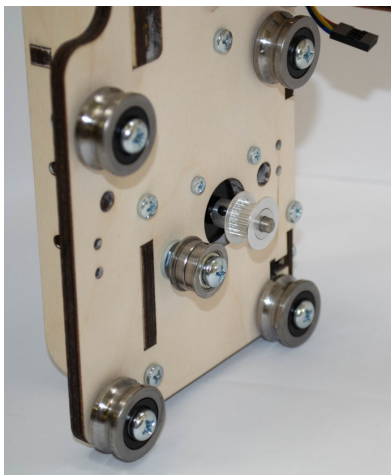

Align outside rim 13mm from face

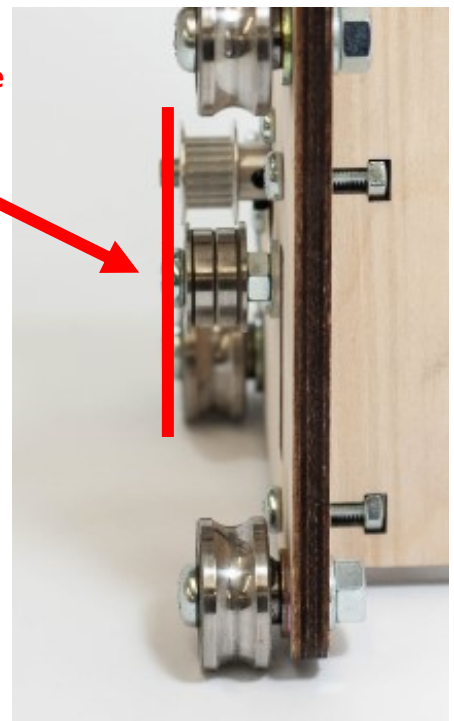



### Step 3

Install the X and Y Stepper Motor Home Switches on the same side of the Gantry, secure each with two M2.5 x 16 Screws and Nuts in the orientation as shown below (Do not over tighten). Mark each Home Switch connector so that you will be able to make the proper connection to the controller.

#### Left Inside View

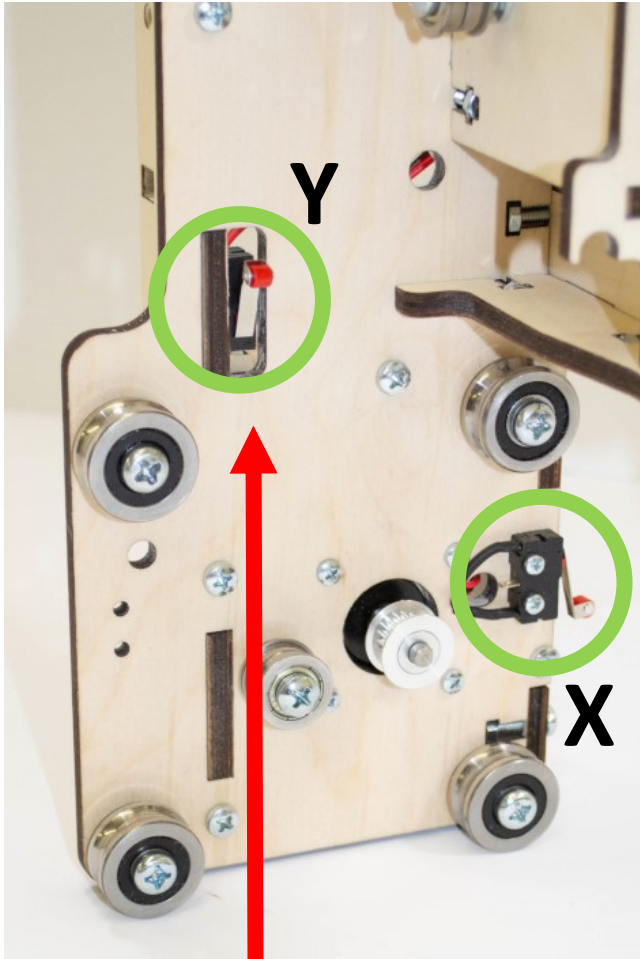

#### Left Outside View

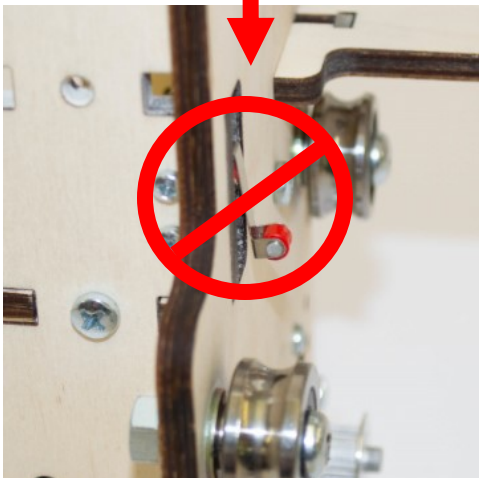
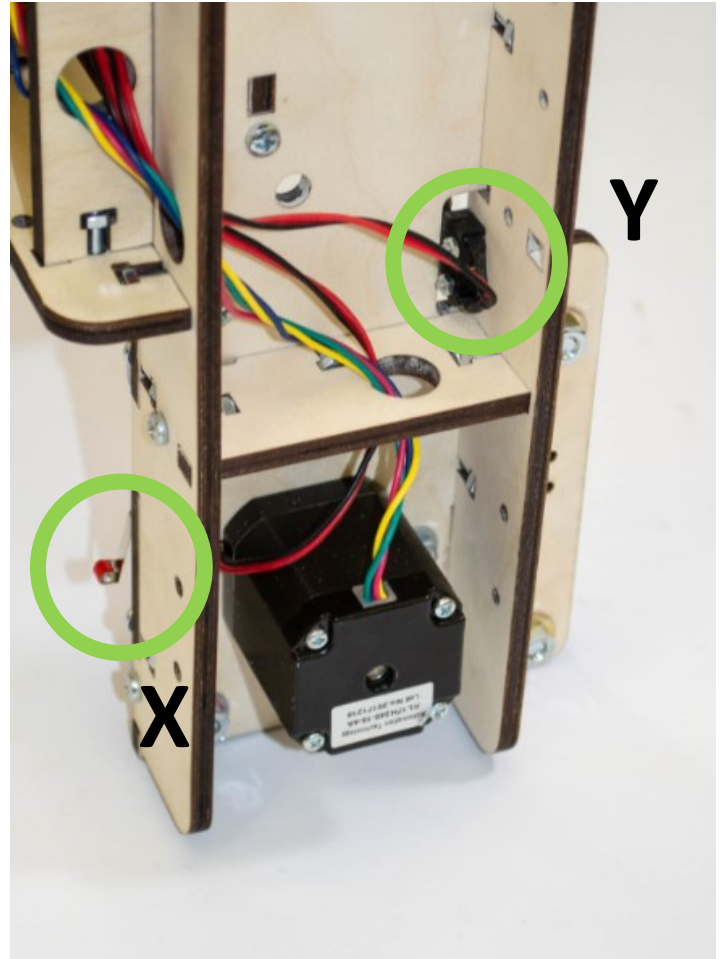

Be sure the home switches are installed as shown. **GREEN** is correct **RED** is incorrect

## Step 4

Carefully wrap the wires with Spiral Wrap then gently route them. There are different ways to route the wires, what important is that the wires are properly wrapped and Secured.



To avoid false triggering the X, Y and Z Home Switches caused by the electrical noise of the Stepper Motor wires, it is a best practice to secure the Home Switch wires with Spiral Wrap every 5 or 6 turns as shown below:

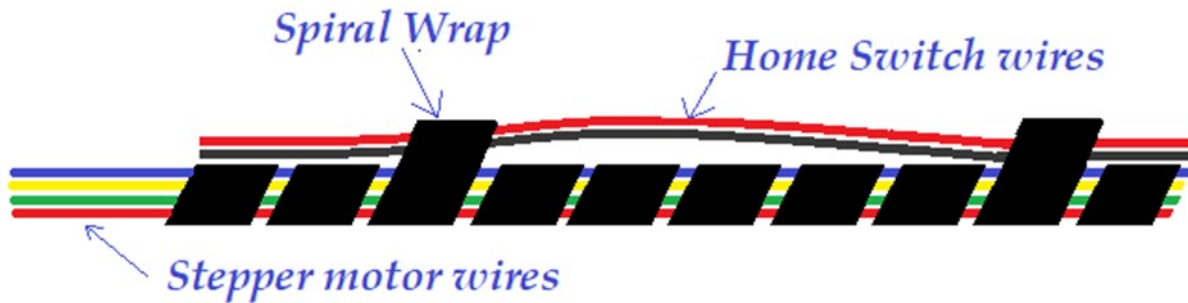

Excess wire can be bundled, then wrapped to control the length of the finished wrapped wire.

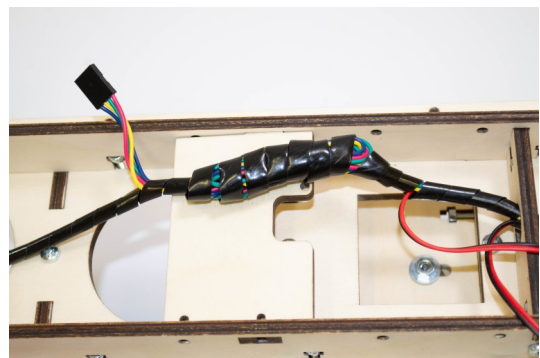
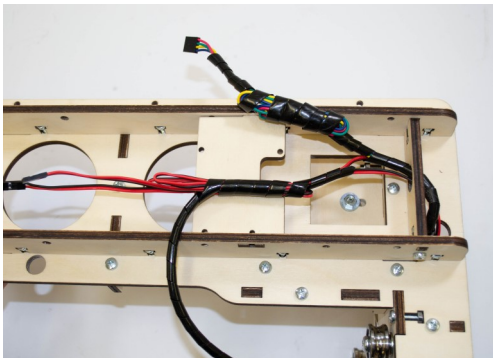
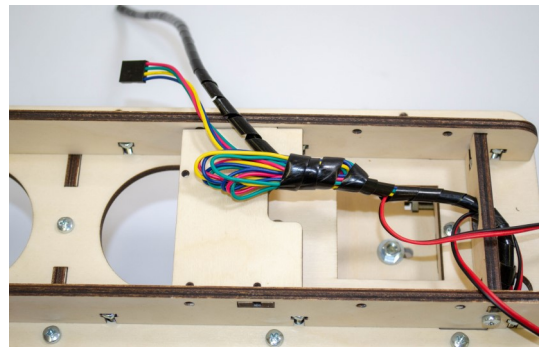
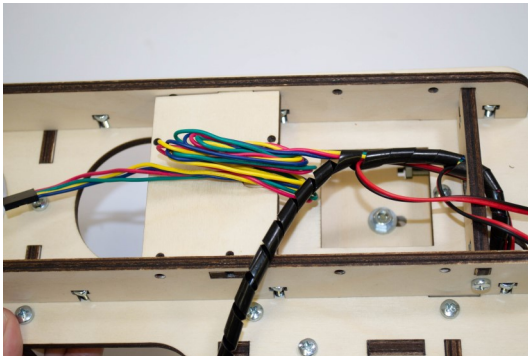

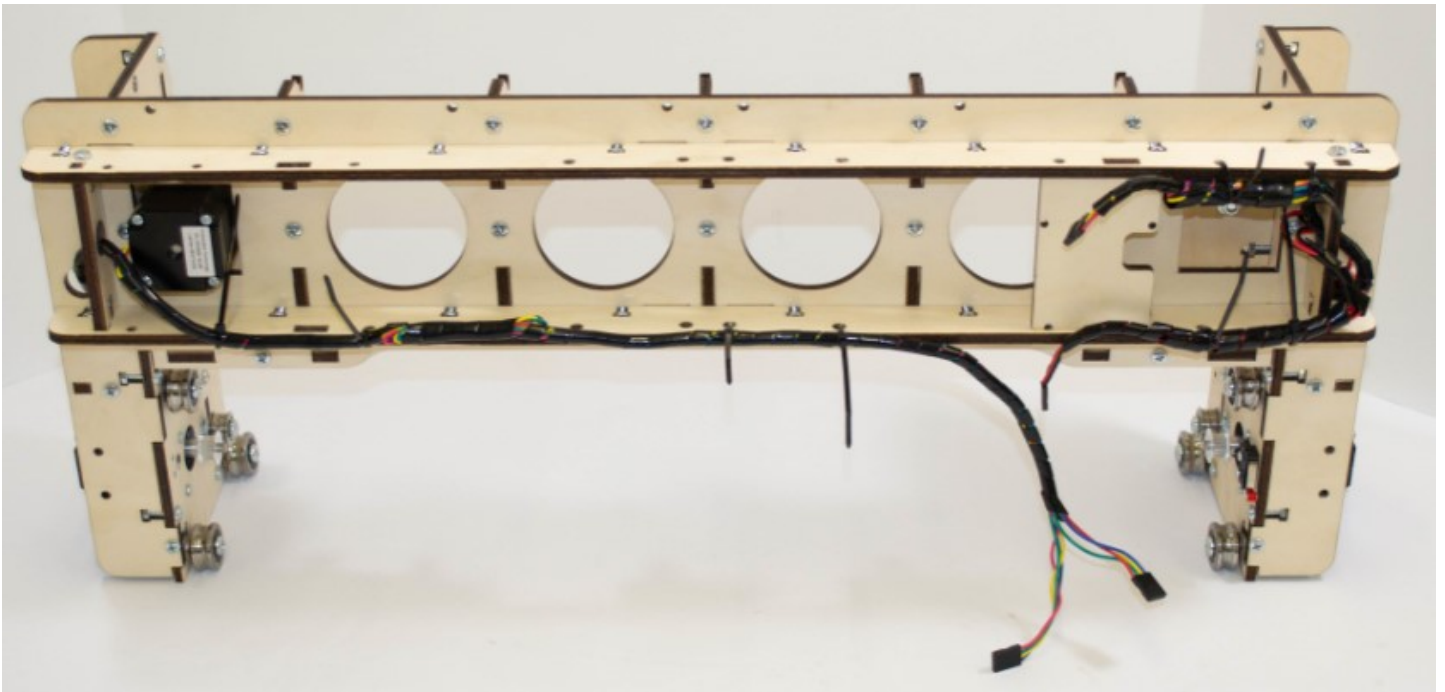
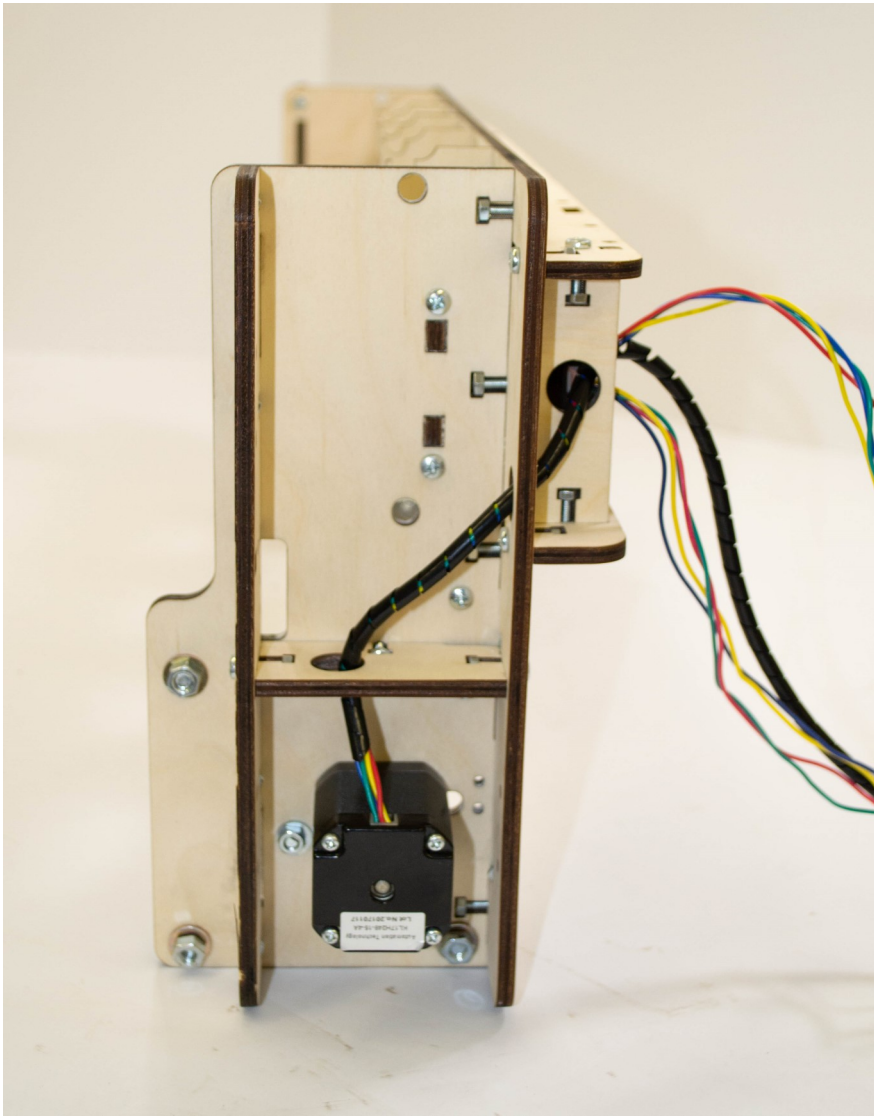



# Gantry Installation Instructions

## Gantry Wood Components & Hardware

1. Gantry Assembly
2. Frame Assembly
3. 4-Long Rods
4. 4-X Rail Stops
5. 8-M4 x 16 screws
6. 8-M4 x 16 nuts

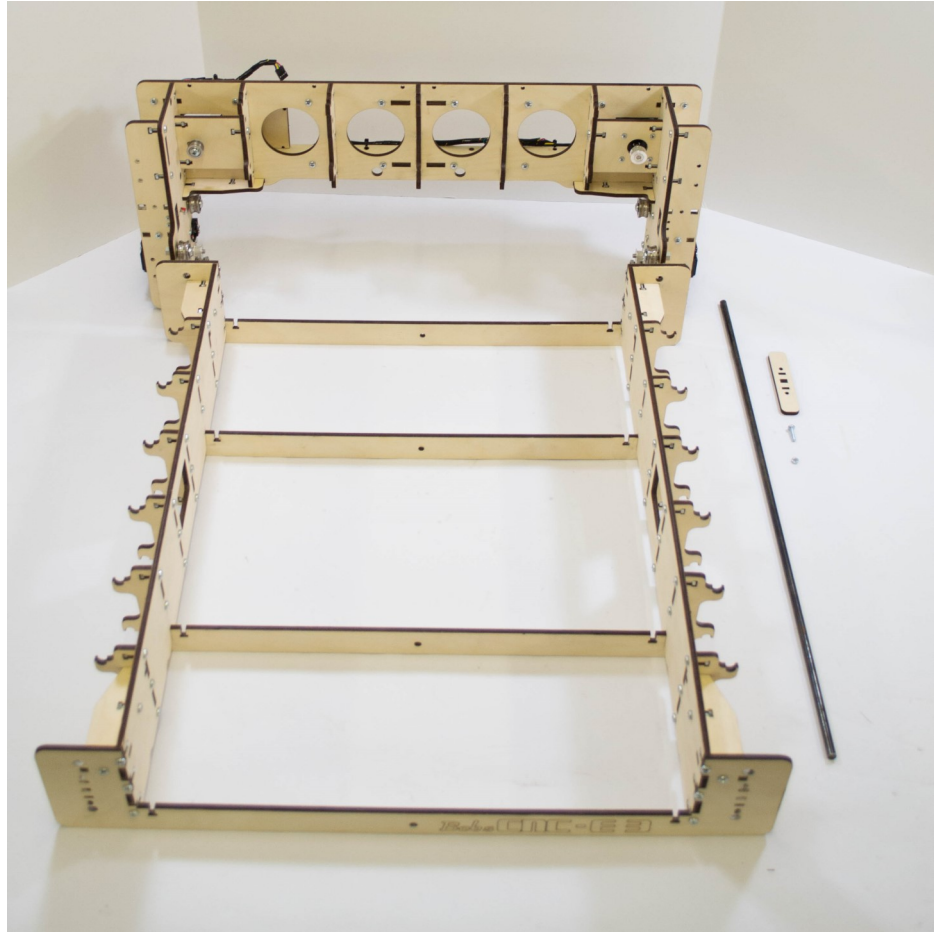

## Step 1

Place two of the X Rail Stops and secure each with two M4 x 16 screws and nuts (these will be thoroughly tightened after the GT2 Drive Belts are installed. See below):



## Step 2

Position Gantry gently over the Main Frame.



## Step 3

Carefully insert the upper rods through the Main Frame and *under the* upper pair of SG20U Bearings, through each of the X Rail supports until the end of the rod is seated in the Frame End Mounts .

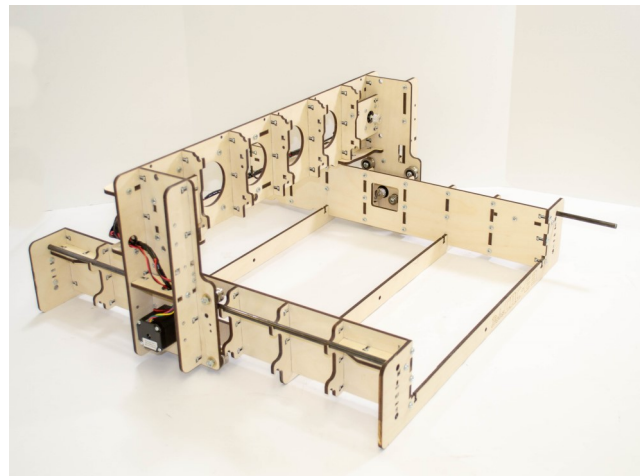
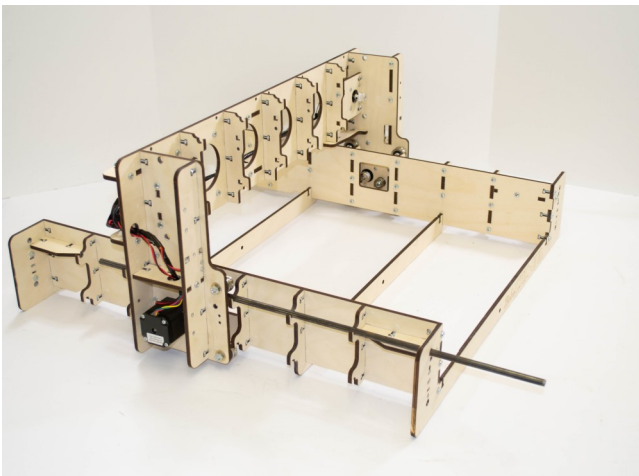



## Step 4

Carefully insert the lower rods through the Main Frame and *over* the bottom pair of SG20U Bearings, through each of the X Rail supports until the end of the rod is seated in the Frame End Mounts.

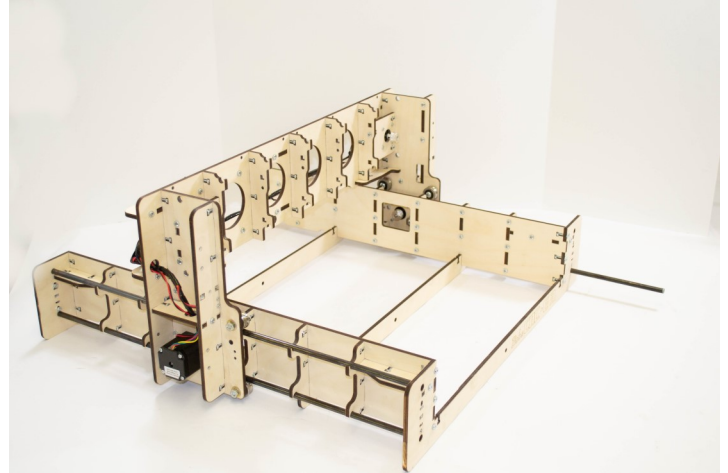
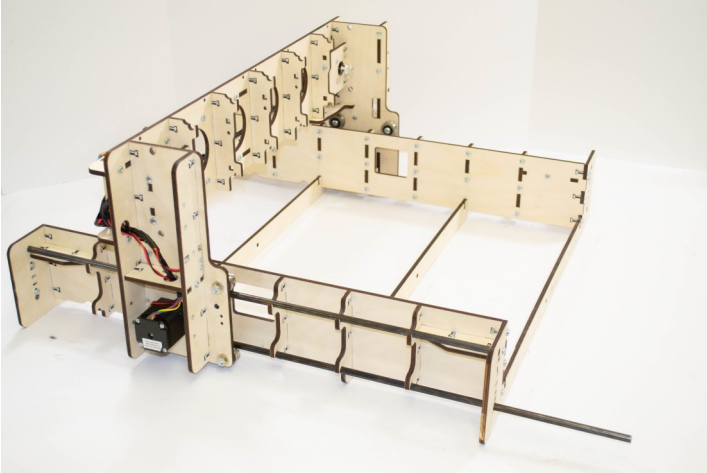

As the SG20U Bearings roll across the rod there should be a small amount of *preload* (i.e., they should securely engage the rail and roll firmly). Check the upper bearings to ensure that they are snug up against the rail. The bearing should move along the rail when rotated by hand.

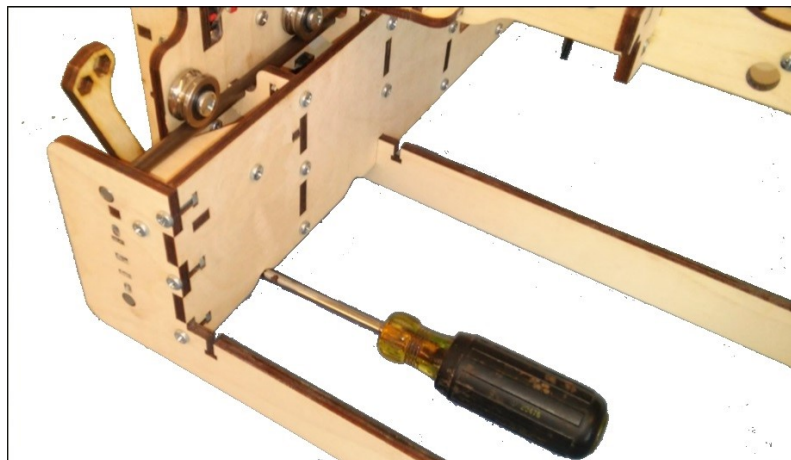

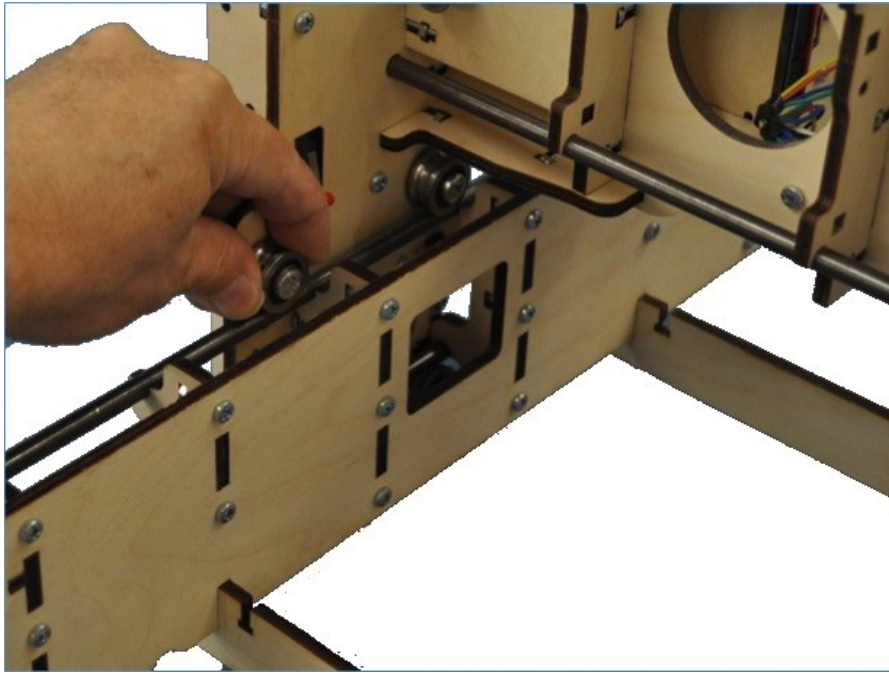

**If any of the bearings rotate without engaging the rail:**

- Remove both of the X rods
- Loosen the 2 nuts on the slotted holes on each side & slide the SG20U bearings upward
- Snug the SG20U bearing nuts
- Repeat steps 1 thru 5.

## **Step 5**

**Place the remaining X Rail Stops to the Frame End Mounts and secure each with two M4 x 16 Screws and Nuts (these will be tightened after the GT2 Drive Belts are installed).**

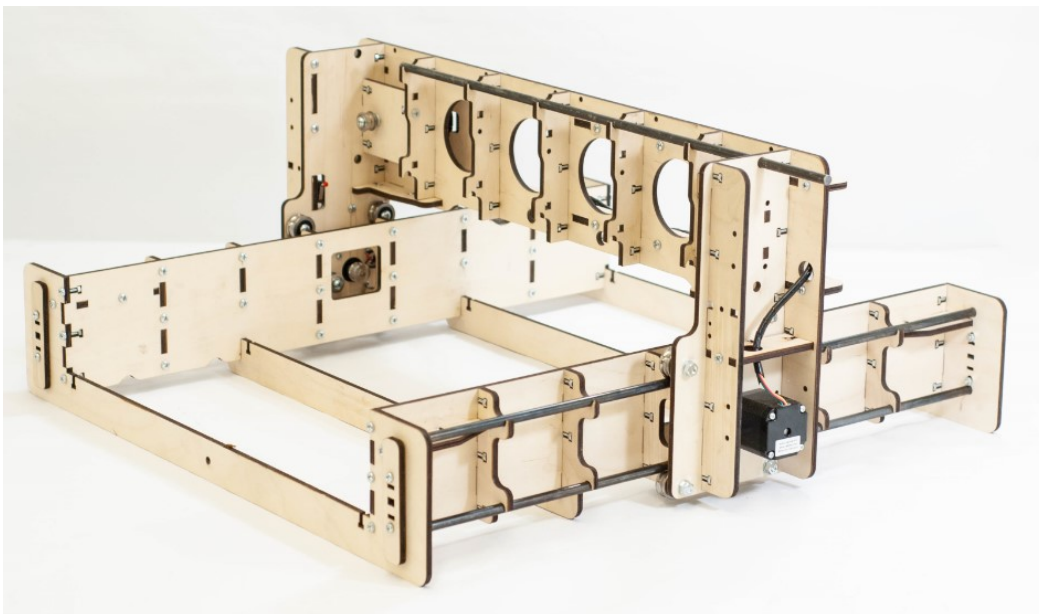

# Y Carriage Installation Instructions

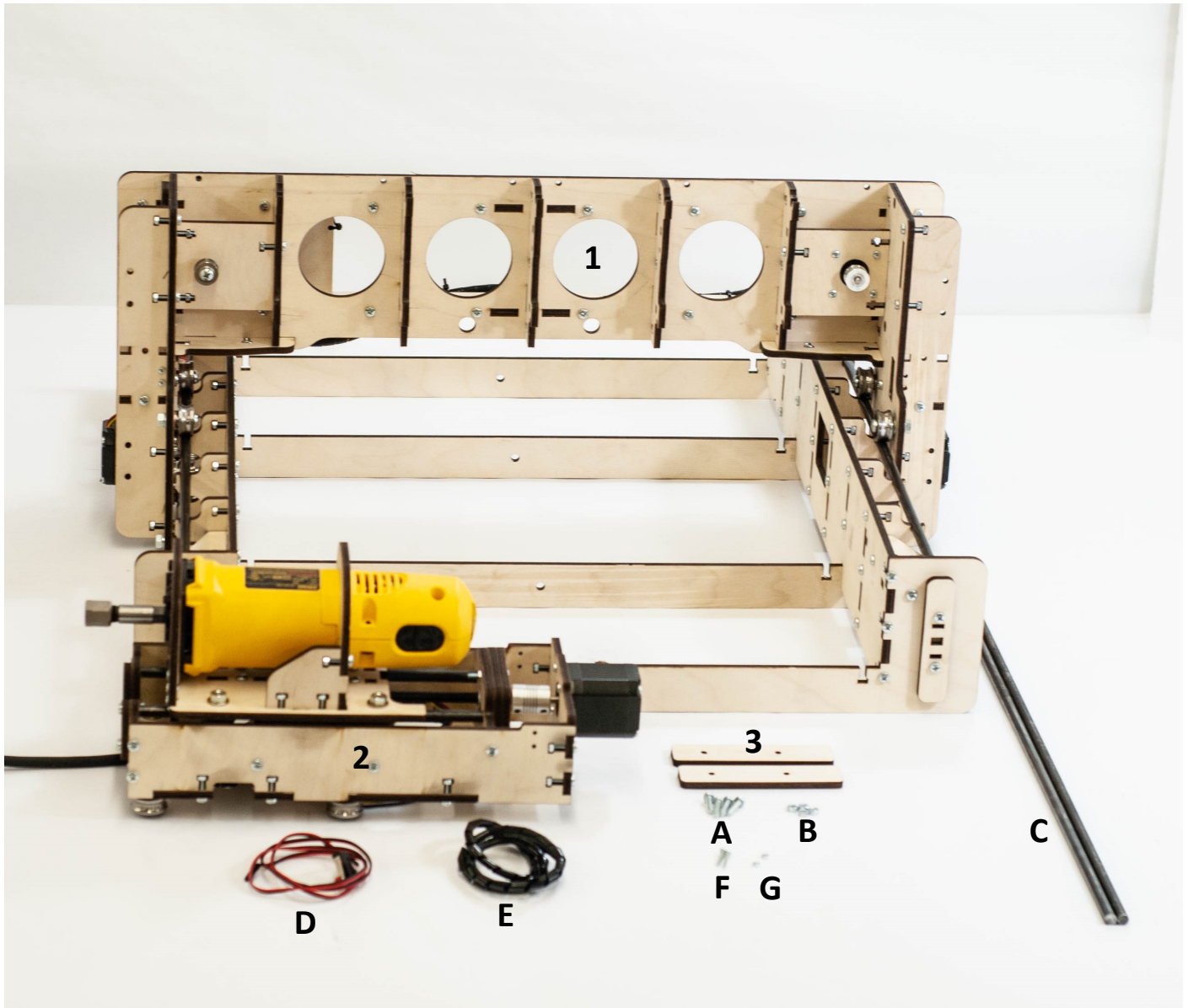

## Parts Required:

| Part # | Qty | Description             |
|--------|-----|-------------------------|
| 1      | 1   | Gantry & Frame Assembly |
| 2      | 2   | Y Carriage Assembly     |
| 3      | 2   | Y Rail Stops            |

| Part # | Qty | Description      |
|--------|-----|------------------|
| A      | 4   | M4 x 25 Screws   |
| B      | 4   | M4 x 25 Nuts     |
| C      | 2   | 8mm Rods         |
| D      | 2   | Switches         |
| E      | 1   | Spiral Wrap      |
| F      | 2   | M2.5 x 16 Screws |
| G      | 2   | M2.5 Nuts        |



**Step 1** Insert the top rod through the Gantry Side and carefully through the Y Rail Supports into the opposite Gantry Side.

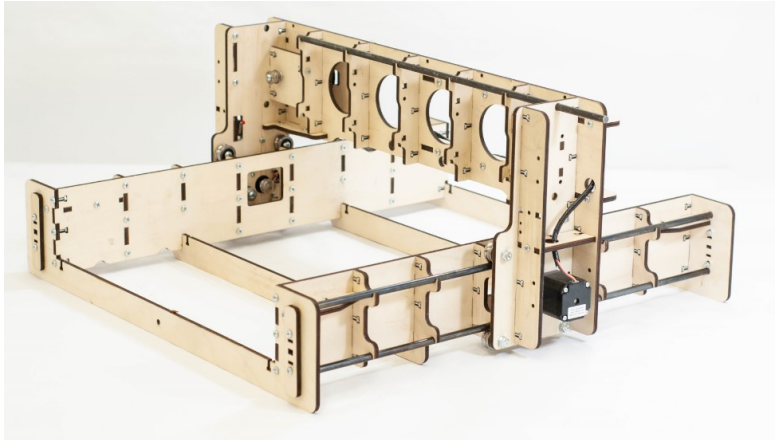

**Step 2** Carefully hang the upper bearings of the Y Carriage assembly onto the rod. Next, insert the bottom Y Rail through the Gantry Side and over the lower set of bearings and through the Y Rail Supports into the opposite Gantry Side.

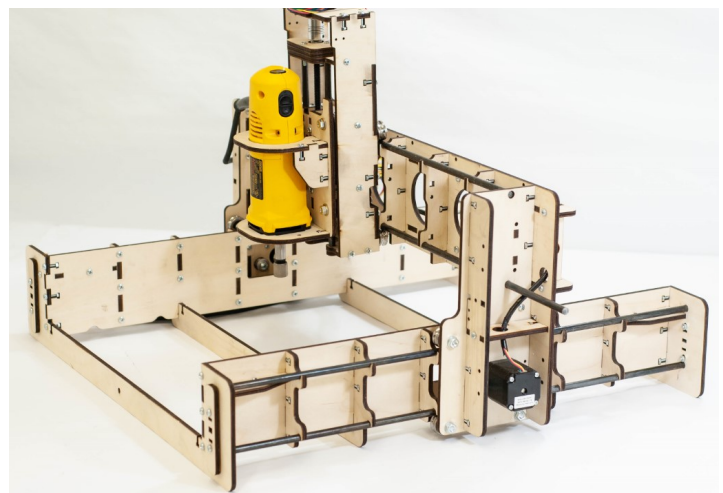
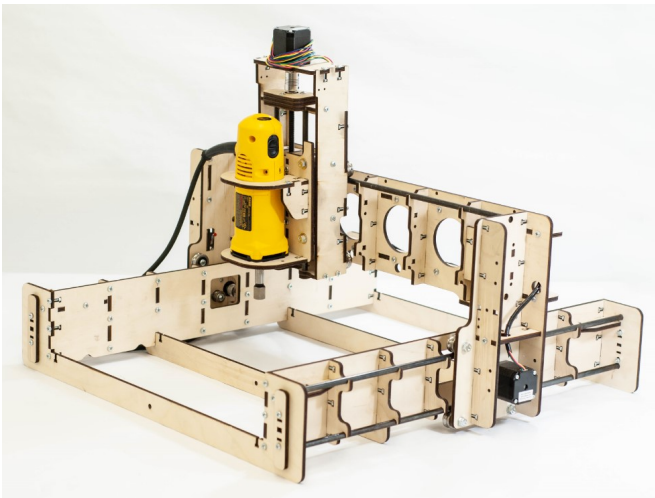

**Step 3** Tighten both SG20U Bearing Nuts on each side one full turn (see below).

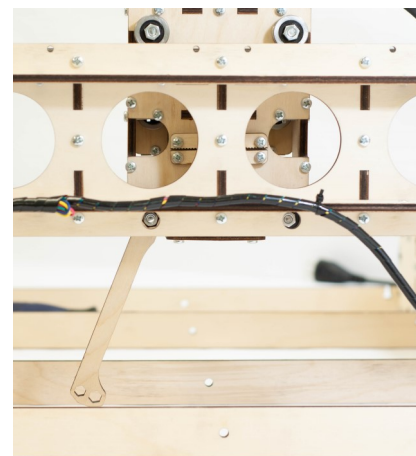
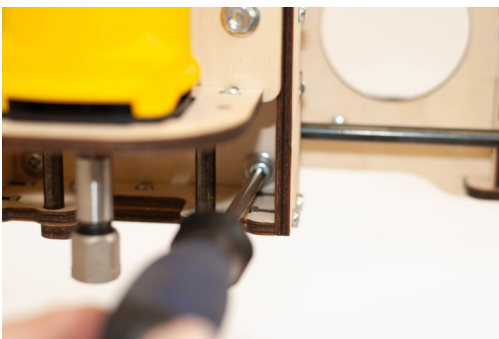



As the SG20U Bearings roll across the rod there should be a small amount of *preload* (i.e., they should securely engage the rail and roll firmly). Check the upper bearings to ensure that they are snug up against the rail. The bearing should move along the rail when rotated by hand.

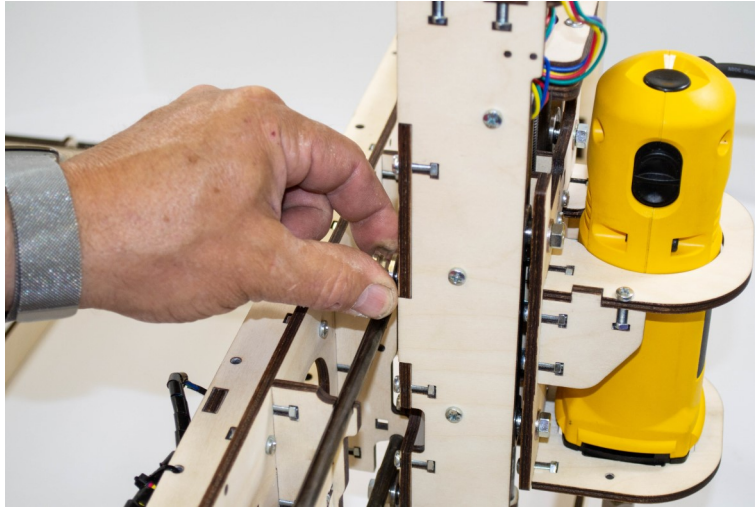

If any of the bearings rotate without engaging the rail:

- Remove both of the Y rods
- Loosen the 2 nuts on the slotted holes on each side and slide the SG20U bearings upward
- Snug the SG20U bearing nuts
- Repeat 1 thru 4.

**Step 4** Place the remaining Y Rail Stops on the Gantry Side and secure each with M4 x 25 screws and nuts. Please note the orientation (the Rail Stop must cover the ends of the rails, keeping them in place).





## Step 5 Attach the Z-Home Switch to the side of the Y Carriage Side Support and secure with two M2.5 x 16 screws and nuts.



Do not overtighten the M2.5 x Screws and Nuts when attaching a switch. Overtightening can cause the switch to fail.

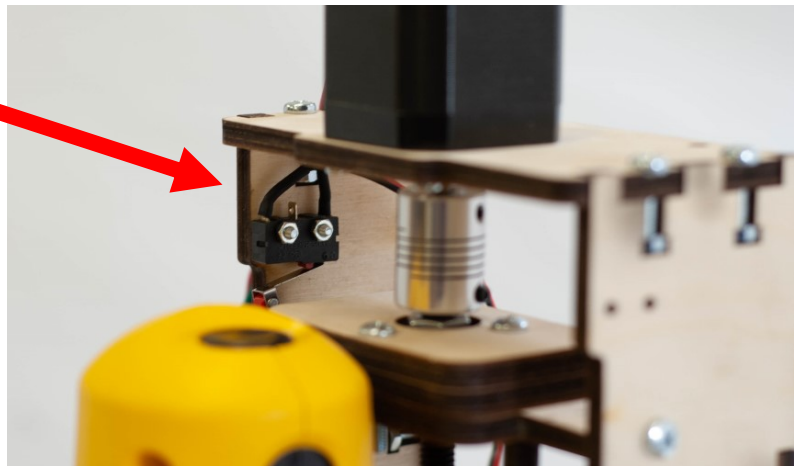

To avoid false triggering the X, Y and Z Home Switches caused by the electrical noise of the Stepper Motor wires, it is a best practice to secure the Home Switch wires with Spiral Wrap every 5 or 6 turns as shown below.

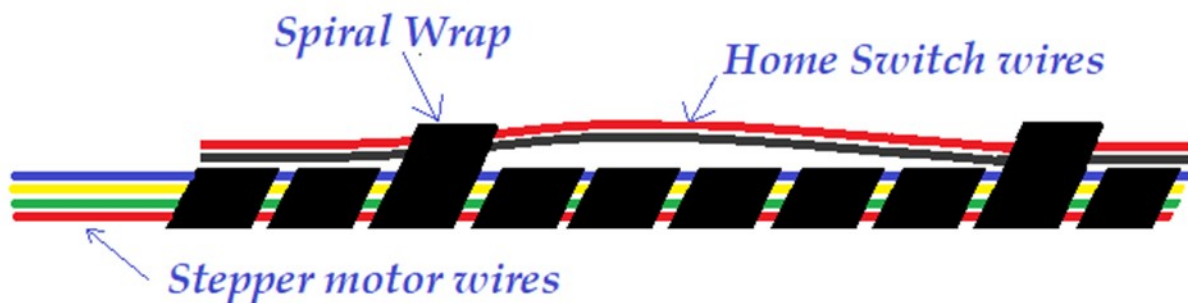

**Step 6** Spiral wrap the Switch Wires and zip tie the wrapped wires as shown.

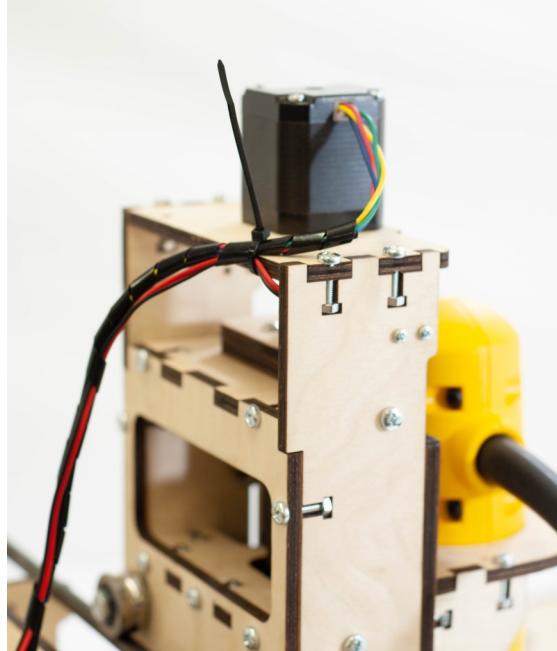

Make certain that the Y Carriage Assembly moves freely from one end to the other on the Rails without binding the wrapped/bundled wiring.

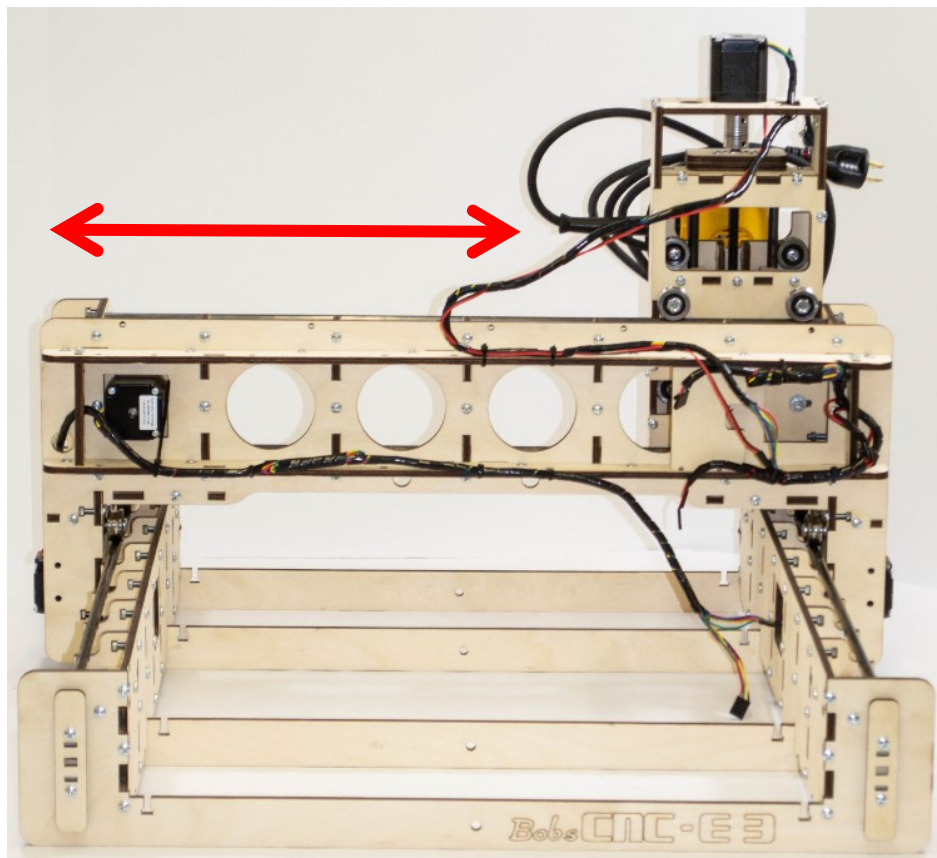

# Installing the Belts

Parts for assembly include:

1. 1-Engraver assembly
2. 2 -X belts
3. 1-Y belt
4. 4-Nylon ties

**Step 1** Route the X-Belt through the top of the Frame End Support and the top slot of the X-Rail Stop slot as shown leaving approximately 2 inches. Push the X-Rail Stop downward to trap the belt and tighten the two M4 x 16 screws.

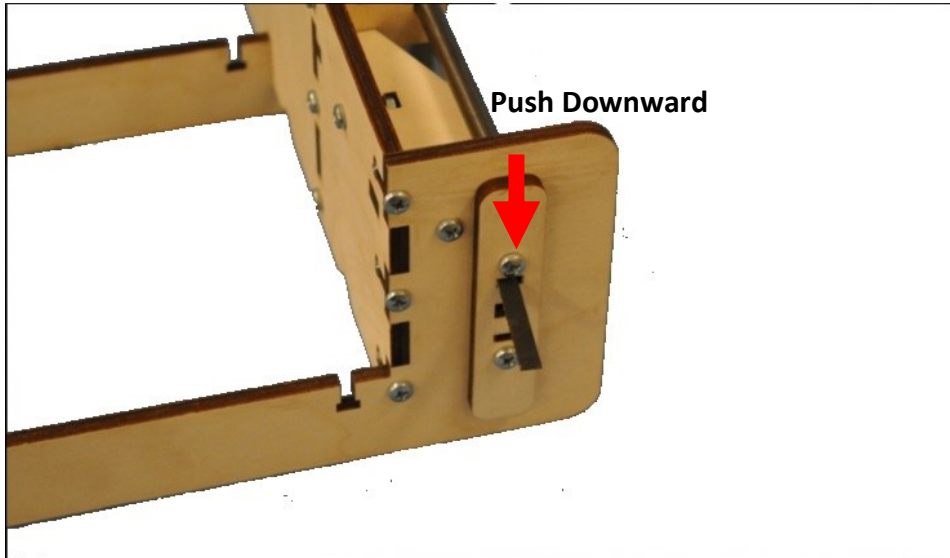

**Step 2** Route the X-Belt through and around the pulley & Idler as shown (note: teeth on belt are engaged in the GT 2 Pulley).

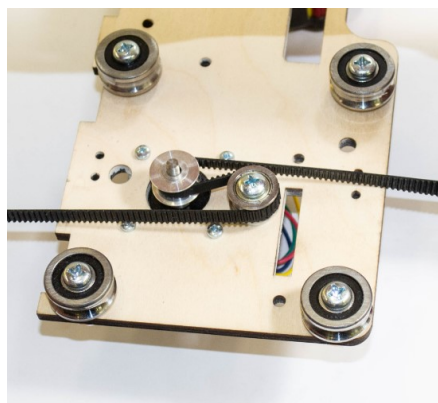

**These photos illustrate how the belt wraps around the GT2 Pulley and Idler.**

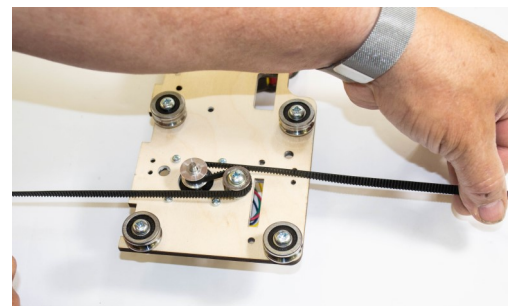
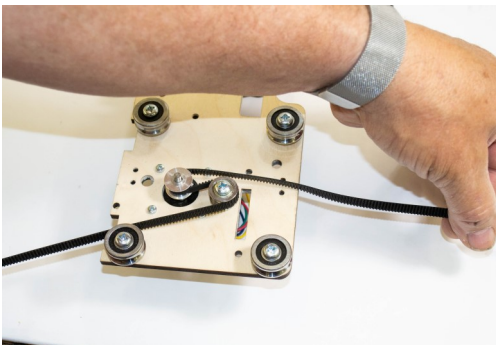
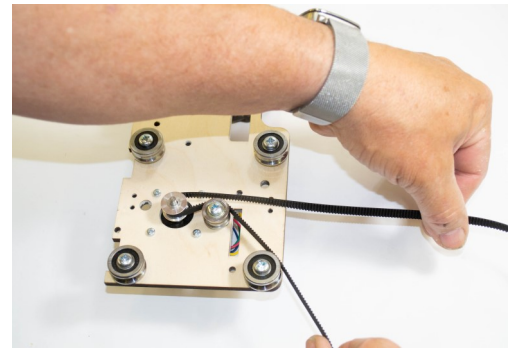
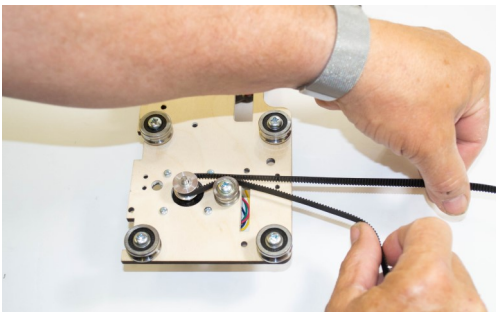
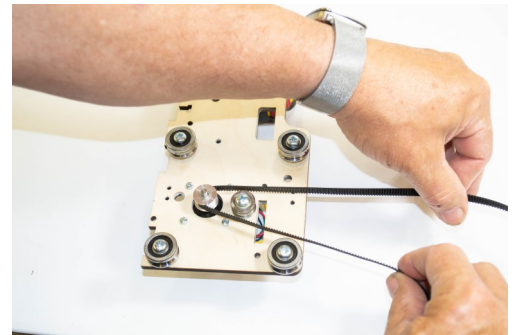
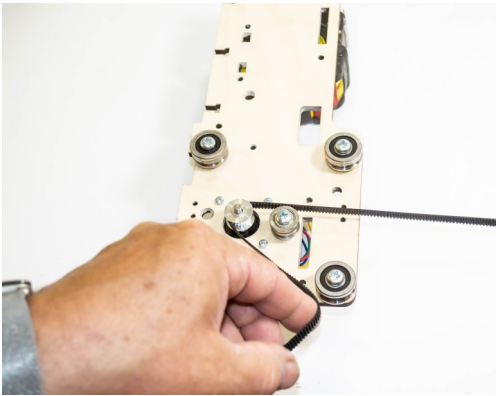
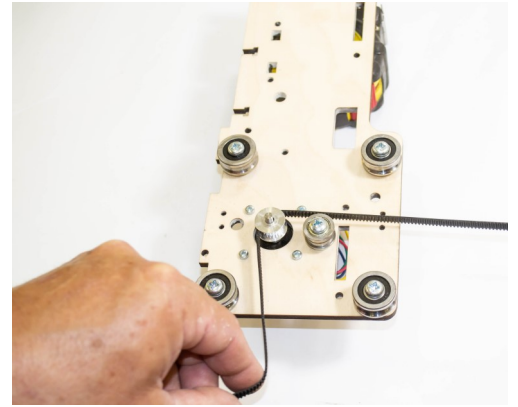
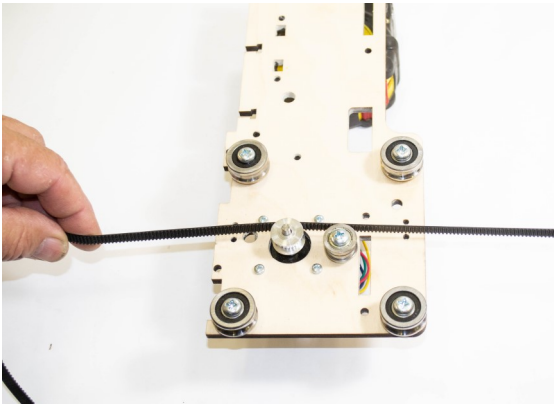



**Step 3** Pull the belt through the lower slot on the X-Rail Stop. While keeping the belt taut, push the X Rail Stop downward to trap the belt. Tighten the M4 x 16 screws.



Be careful not to overtighten the belt. There should be no more than 1" of deflection in the belt.



**Step 4** Loop the belts through the X-Rail Stops and Frame End Supports through the large middle slot and secure the loose end to the belt with a small zip tie. Trim excess belt and zip tie as shown below. Repeat with belt on other side.



Left Side View



Right Side View



**Step 5** Route the Y Belt into the Belt Retainer as shown.

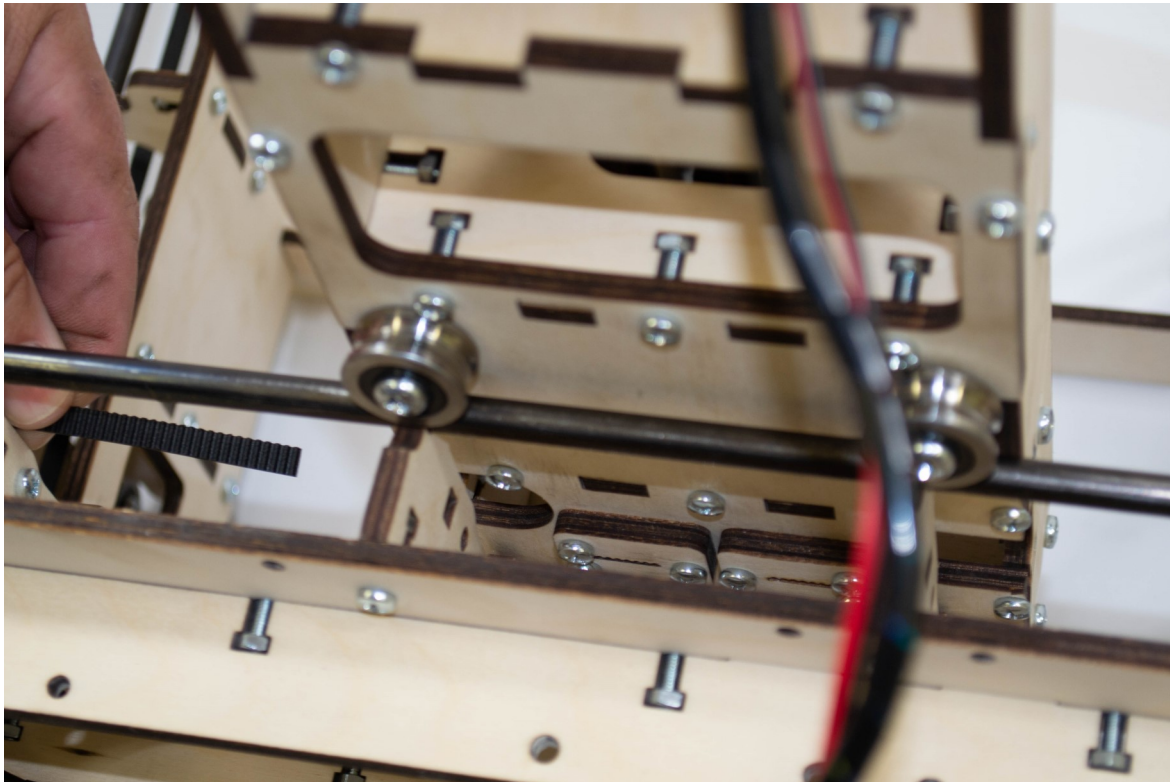

**Step 6** Route the loose end of the Y Belt around the GT2 Pulley and Idler and secure the loose end into the other Belt Retainer. (Be sure the teeth on the Belt engage the teeth on the GT2 Pulley.)



**Step 7** Tighten the belt by moving the Idler and tightening the Idler screw and nut. Shorten belt if needed (see below):

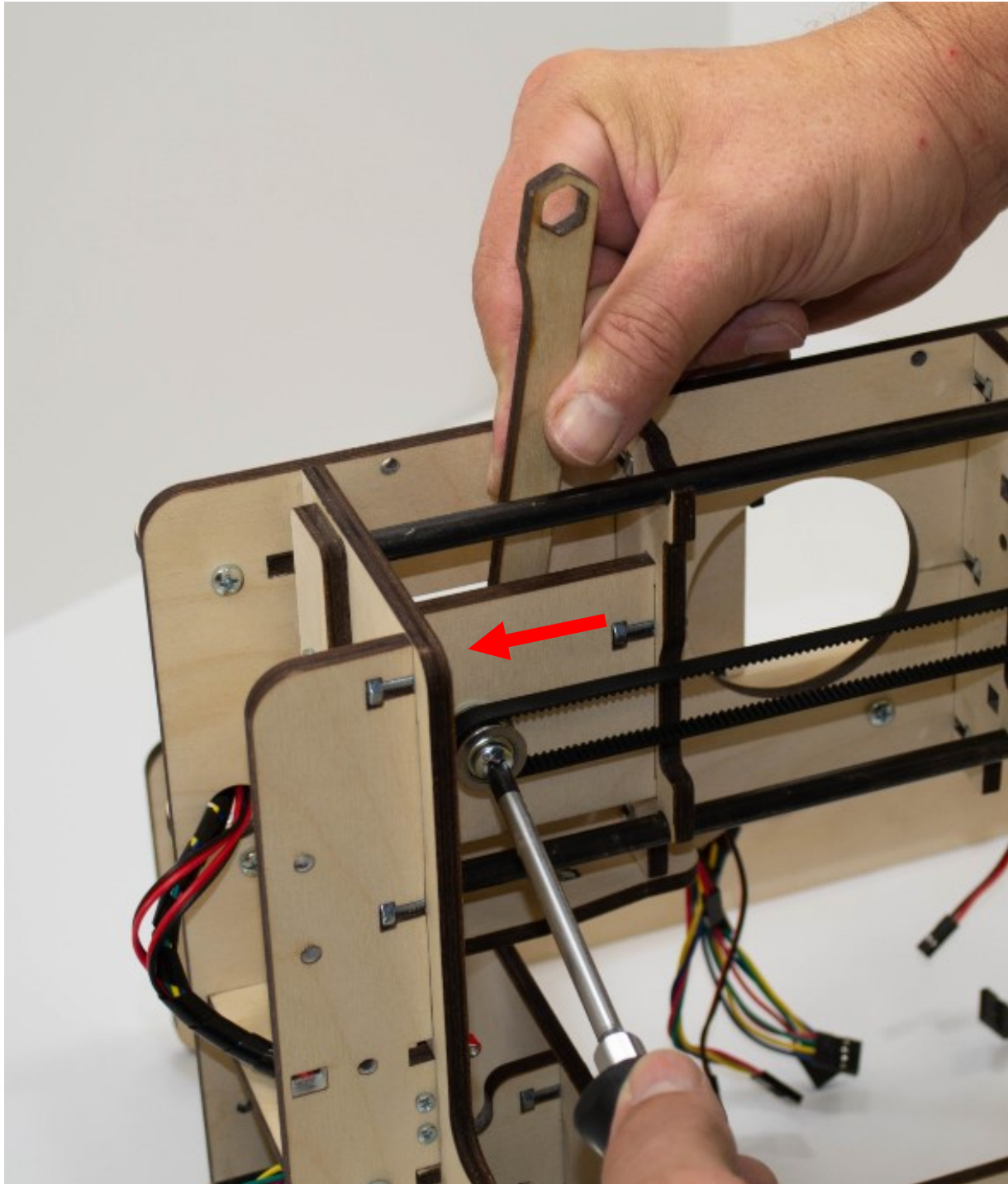

## Installing the Spoilboard

Parts for assembly include:

1. 1-Engraver assembly
2. 1 Spoilboard
3. 8-M4 x 16 screws
4. 8-M4 nuts

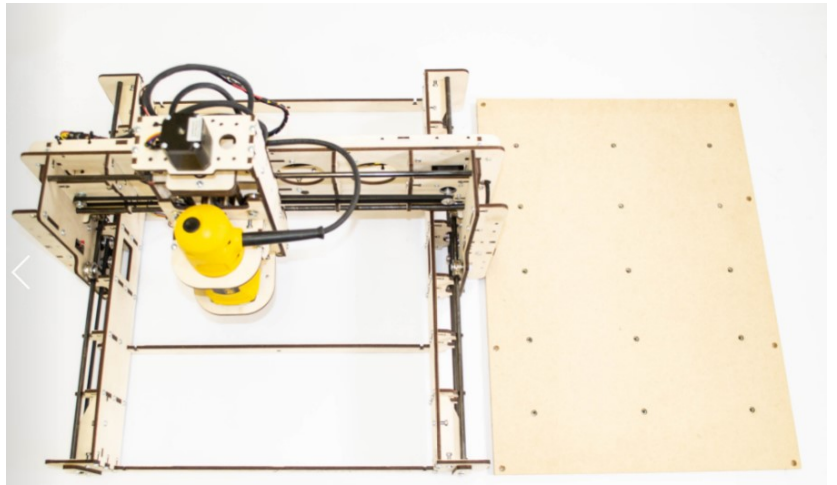

**Step 1** Place M4 nuts into the slots on the Frame End and Frame Mid Support.



**Step 2** Gently set the Spoilboard into position. Be sure the thread insert flanges face down).

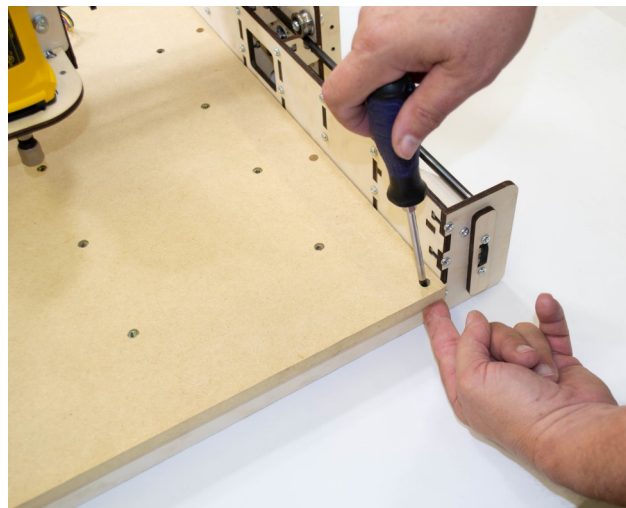



**Step 3** Measure and align the front edge of the Spoilboard to ensure the Frame is square, then secure with eight M4 x 16 screws.



## Initial Setup

**Step 1** Connect the wire mounts on each side and secure with two M4 x 16 Screws and Nuts as shown below:

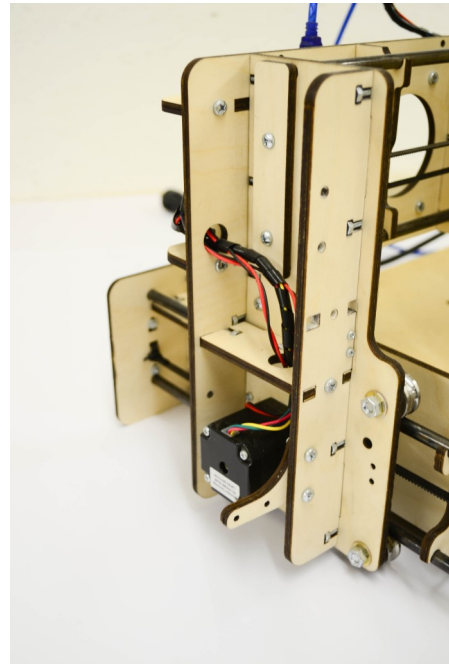
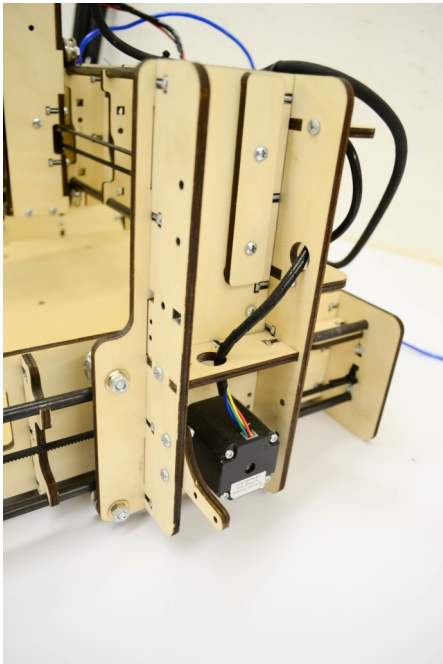



**Step 2** Secure the Controller with 4 Small Zip Ties as shown. Be careful not to overtighten which can damage the Controller.

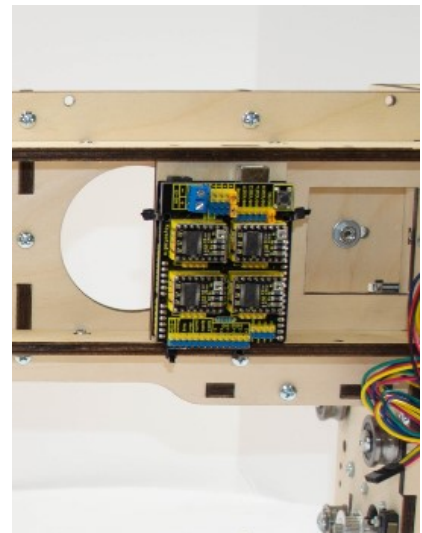
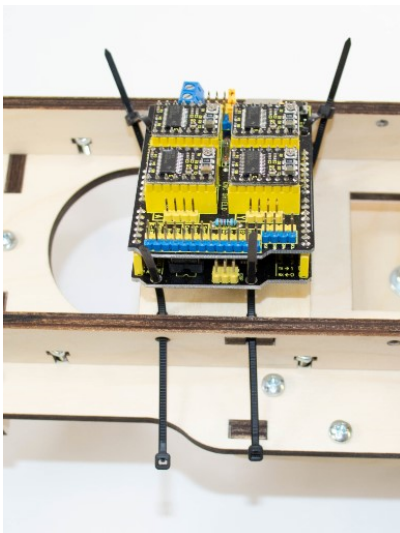
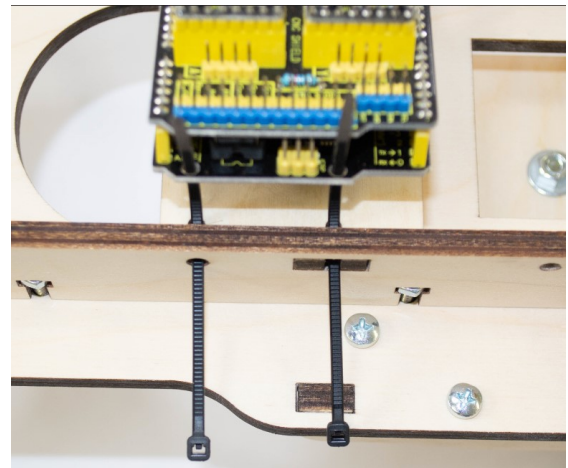
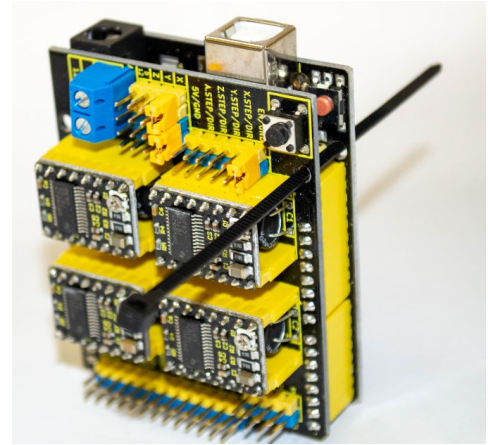
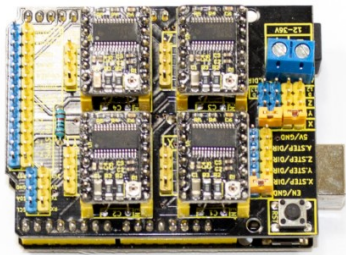

**Step 3** Attach USB cable to controller as shown.

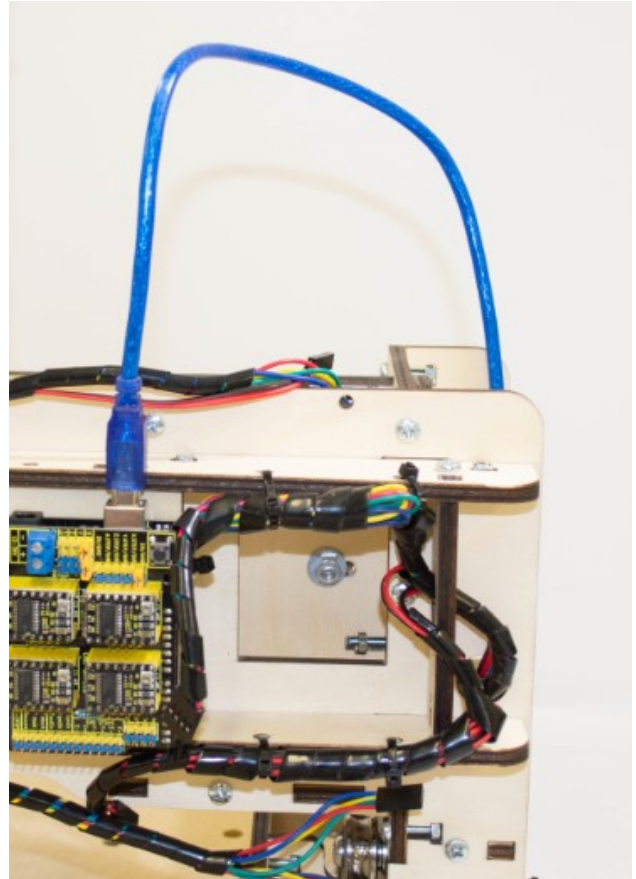

**Step 4** Loop USB cable from the Controller and secure to Gantry Frame with Small Zip Ties.

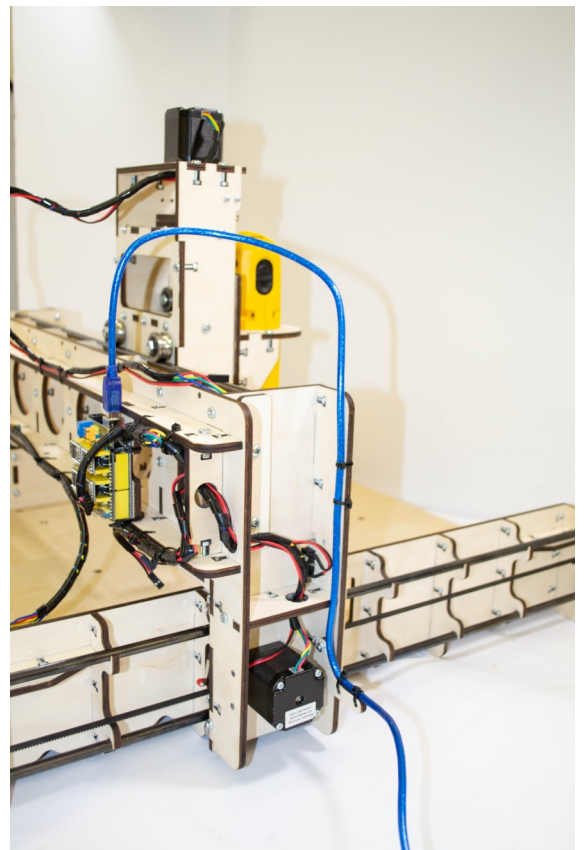

**Step 5** Route the Power Supply as shown, connect to Controller and secure in place with Small Zip Ties.

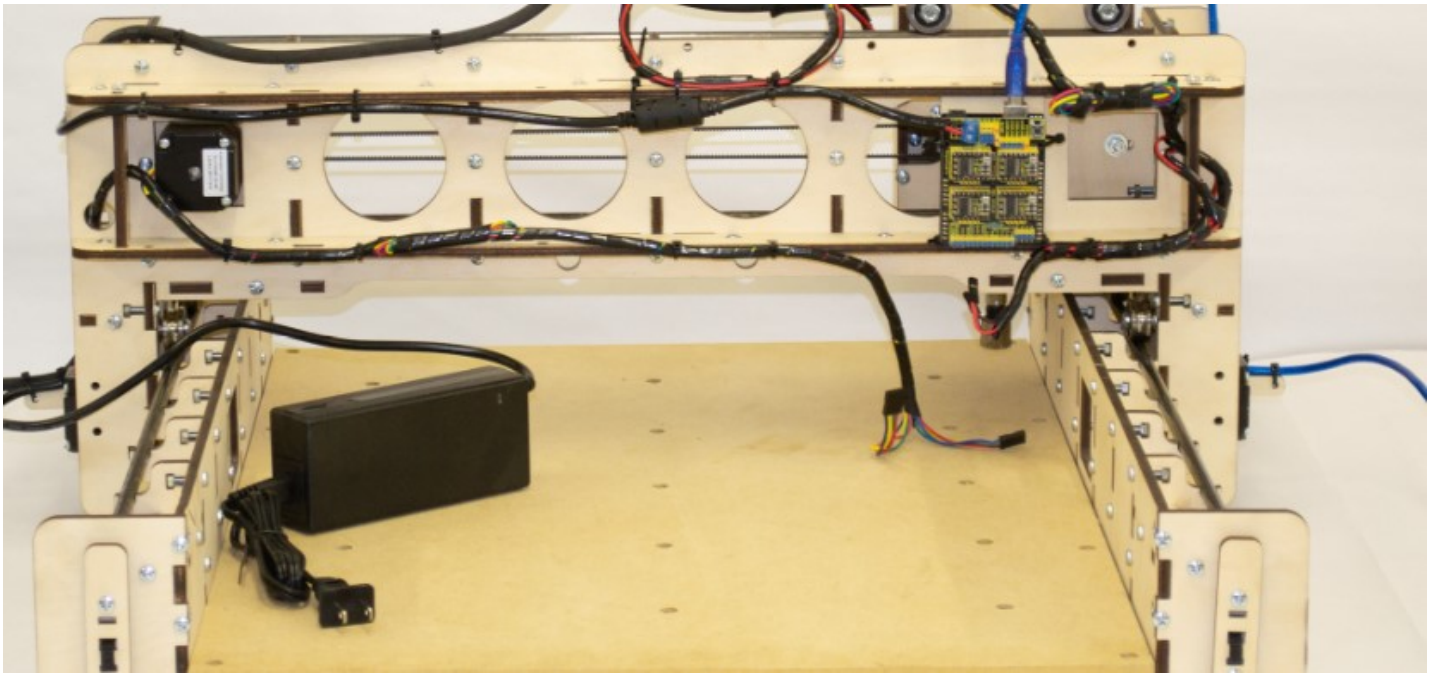



## Tips to keep your controller from being damaged.

- Always unplug the power supply when connecting or disconnecting the stepper motor connectors.
- Make sure all 4 pins are connected for each stepper motor. It is really easy to get the connector offset by one pin.
- Check and double check your connections before applying power to the board.

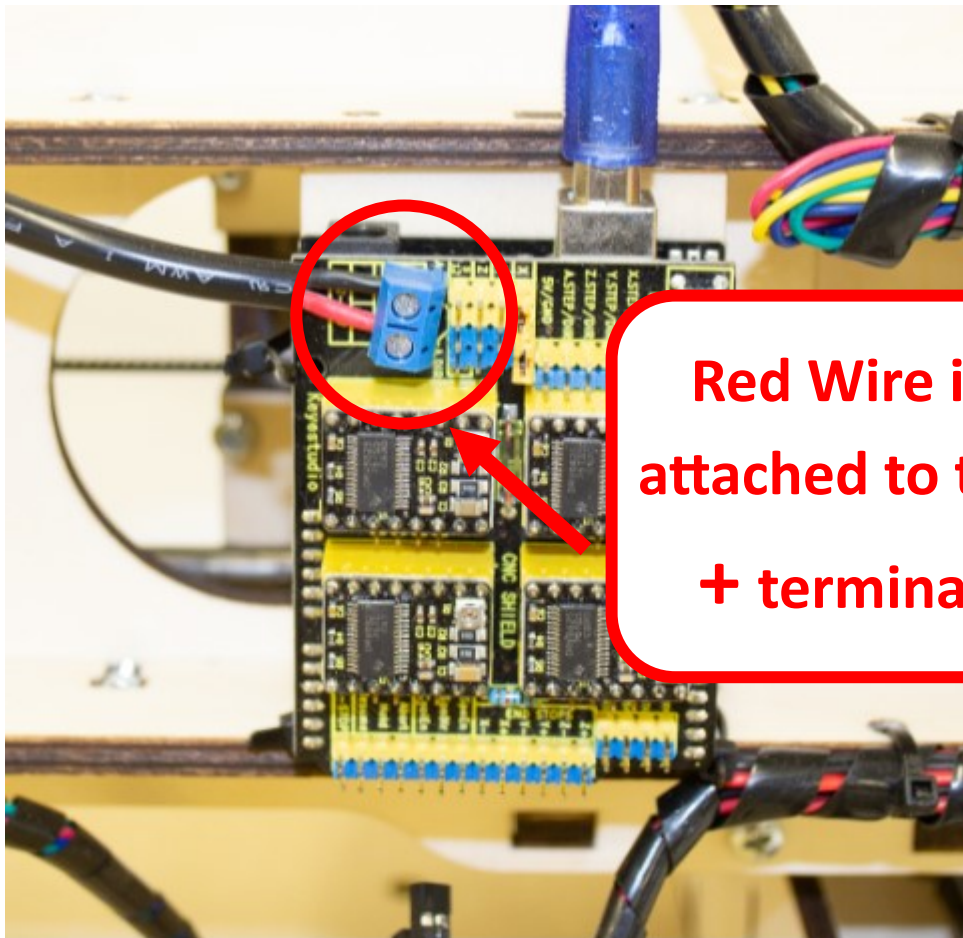





Make sure the Negative (-) is connected to the white or black wire and the Positive (+) is connected to the red or blue wire. Incorrect connections will damage the controller.

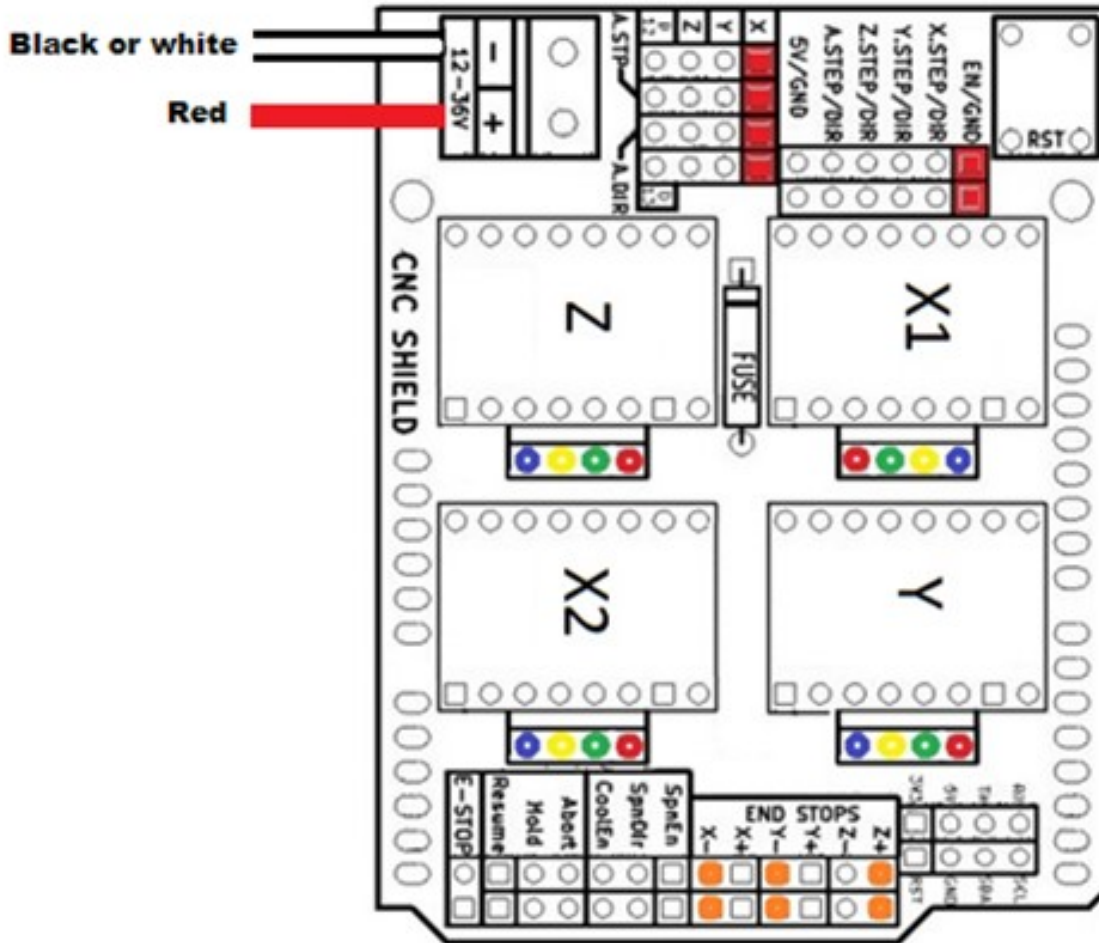

Note that the X1 Stepper orientation is opposite the others. (the red wire is on the left in the diagram and picture) 

See page 57 for X1 and X2 motor location.

Home switch wires do not have polarity. The home switches are connected to the X-, Y, and Z + as shown in orange in the diagram.

The red squares in the diagram are jumper connectors



**PLEASE—CAREFULLY FOLLOW THESE INSTRUCTIONS TO KEEP FROM DAMAGING THE CONTROLLER.**

## GRBL and Universal G-code Sender Software

- Version 1.1e of GRBL has been uploaded to the controller.
- There are several G-code senders for GRBL. I have had success with the Universal G-code Sender Platform Version
- Some of the firmware values can be changed from the G-code sender software. Below is a table for the default values uploaded into the firmware from GRBL 1.1e.
- Please see our [Quick Start guide](#) for getting started with the drivers and initial settings.
- Please see our [troubleshooting guide](#) for getting started with the drivers and initial settings.

| Key   | Value    | Description                                    |
|-------|----------|--|
| \$0   | 5        | (Step pulse time, microseconds)                |
| \$1   | 25       | (Step idle delay, milliseconds)                |
| \$2   | 0        | (Step pulse invert, mask)                      |
| \$3   | 0        | (Step direction invert, mask)                  |
| \$4   | 0        | (Invert step enable pin, boolean)              |
| \$5   | 1        | (Invert limit pins, boolean)                   |
| \$6   | 0        | (Invert probe pin, boolean)                    |
| \$10  | 1        | (Status report options, mask)                  |
| \$11  | 0.01     | (Junction deviation, millimeters)              |
| \$12  | 0.002    | (Arc tolerance, millimeters)                   |
| \$13  | 1        | (Report in inches, boolean)                    |
| \$20  | 1        | (Soft limits enable, boolean)                  |
| \$21  | 0        | (Hard limits enable, boolean)                  |
| \$22  | 1        | (Homing cycle enable, boolean)                 |
| \$23  | 3        | (Homing direction invert, mask)                |
| \$24  | 500      | (Homing locate feed rate, mm/min)              |
| \$25  | 8000     | (Homing search seek rate, mm/min)              |
| \$26  | 250      | (Homing switch debounce delay, milliseconds)   |
| \$27  | 5        | (Homing switch pull-off distance, millimeters) |
| \$30  | 1000     | (Maximum spindle speed, RPM)                   |
| \$31  | 0        | (Minimum spindle speed, RPM)                   |
| \$32  | 0        | (Laser-mode enable, boolean)                   |
| \$100 | 80       | (X-axis travel resolution, step/mm)            |
| \$101 | 80       | (Y axis travel resolution, step/mm)            |
| \$102 | 2267.717 | (Z-axis travel resolution, step/mm)            |
| \$110 | 10000    | (X-axis maximum rate, mm/min)                  |
| \$111 | 10000    | (Y axis maximum rate, mm/min)                  |
| \$112 | 500      | (Z-axis maximum rate, mm/min)                  |
| \$120 | 800      | (X-axis acceleration, mm/sec <sup>2</sup> )    |
| \$121 | 800      | (Y axis acceleration, mm/sec <sup>2</sup> )    |
| \$122 | 300      | (Z-axis acceleration, mm/sec <sup>2</sup> )    |
| \$130 | 450      | (X-axis maximum travel, millimeters)           |
| \$131 | 390      | (Y axis maximum travel, millimeters)           |
| \$132 | 85       | (Z-axis maximum travel, millimeters)           |

## Quick Start Guide

[Quick start](#) and [troubleshooting](#) guides are available and can help you get up and running. Please check [BobsCNC.com](http://BobsCNC.com) for the latest copy.

### Axis Definitions and Home Location

The engraver is setup using the right-hand coordinate system. The arrows in the diagram below displays the positive direction for both the X and the Y axis. The positive Z axis is up. Once connected the first operation should be to home the engraver. The home position will move the engraver to the X0 Y0 location with Z is in maximum distance away from the work.

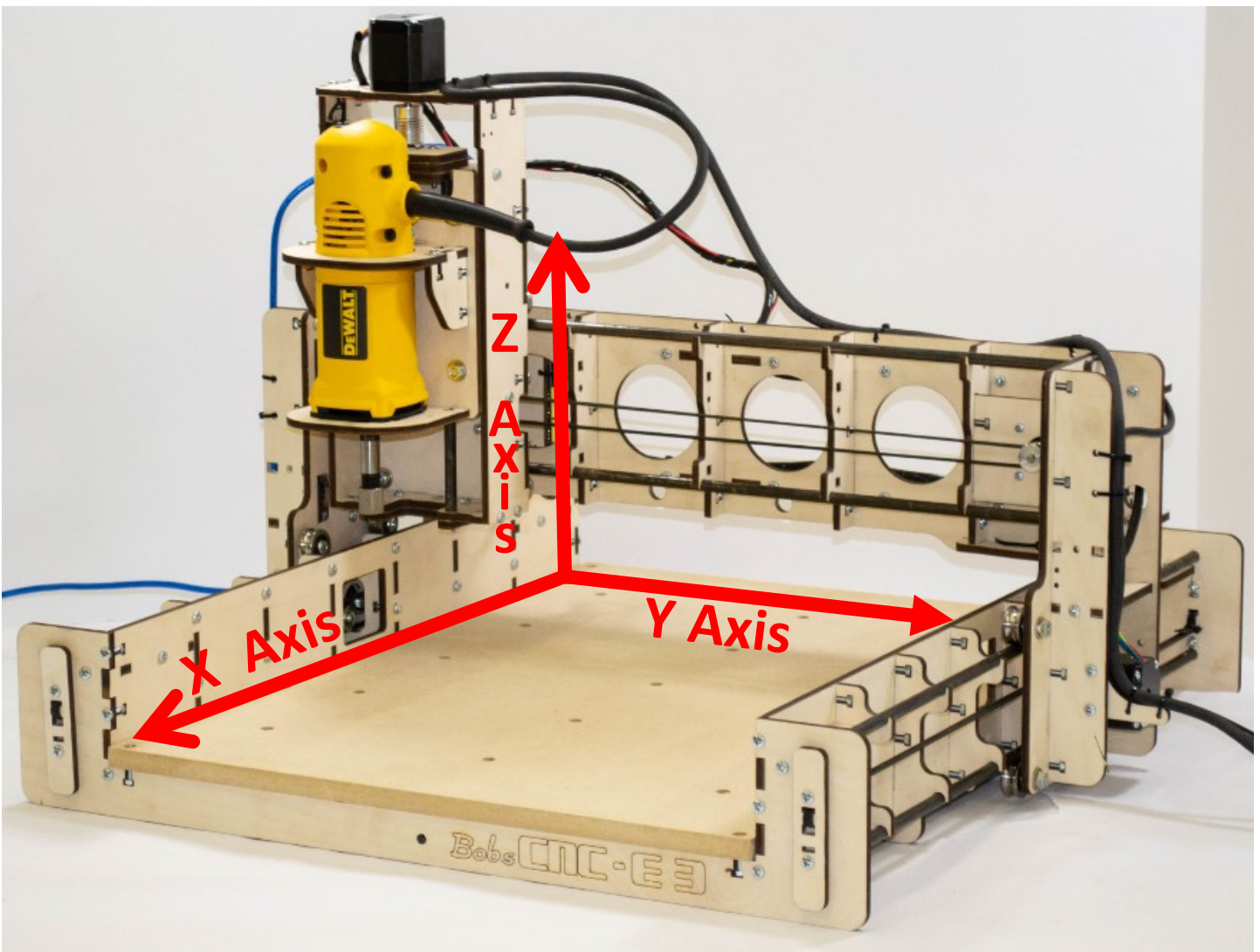

## Mounting the Work.



The DeWalt Rotary Tool should **NEVER** be plugged in when mounting a work piece. Always unplug the power supply when removing or installing router bits. Failure to follow this simple procedure may result in serious personal injury.

The E3 kit includes clamping hardware. Insert the wing nut onto the 2" ¼-20 screw as shown. The screws will thread into the inserts on the table. The extra clamps can be used as spacers as shown in the pictures.

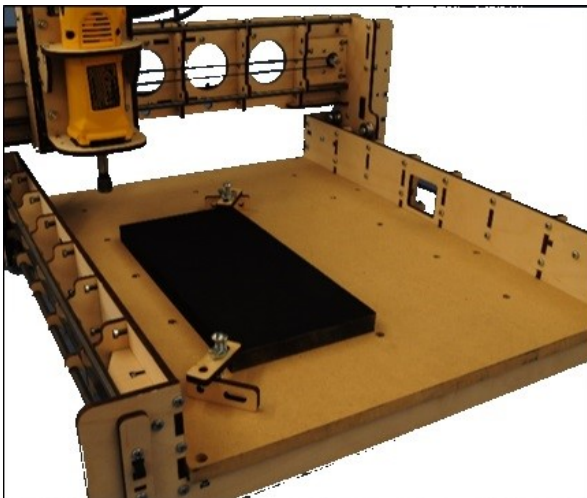

If you are new to CNC Routing we offer a quick start guide to walk you thru the software setup and help get you routing. Please check [BobsCNC.com](http://BobsCNC.com) for the latest copy.

### Tips for cutting with the E3



- Always unplug the router before changing the bits
- Do not leave the router unattended.
- Use a scrap board underneath the work to keep from engraving into the spoil board.
- For work such as isolation routing for circuit boards, consider milling a scrap blank, then use double-sided tape to fasten the circuit board.



## Appendix

### **Warranty and Return Policy**

#### **60 Day Warranty**

BobsCNC guarantees all supplied parts for 60 days after the purchase date. If any parts are missing or defective, the buyer must contact BobsCNC during within the 60-day time frame using the Contact Us Form located at BobsCNC.com at: <https://www.bobscnc.com/pages/contact-us>).

After 60 days, no warranty is given nor will any refund be offered.

#### **Refund Policy**

The customer has thirty (30) days from receipt of the product to request a refund on a purchase. No refund will be offered on any purchase after thirty (30) days. To receive a refund, the customer must make their request using the *Contact Us Form* at BobsCNC.com.

**The kit must be returned to BobsCNC in its original unassembled condition.** Customers requesting a refund after assembling or partially assembling the kit must disassemble and repackage the kit to its original unassembled condition. Customers who return assembled or partially assembled kits that have not been disassembled will be charged a 15% restocking fee.

**Refunds will only be processed after the kit has been received and inspected by BobsCNC.** If any parts are missing or damaged the customer agrees to pay for all required replacement parts as listed in the E3 Replacement Part List. The cost of replacement parts will be deducted from the original purchase price. BobsCNC will provide documentation validating any necessary deductions from the original purchase price. Bobs CNC retains sole discretion to determine if a kit or any part of the kit is eligible for a refund.

## Software

No warranty is given nor will any refund be offered for Vectric software. Please see the **“try before you buy”** on Vectric’s webpage <http://www.vectric.com/downloads/trial-software.html>. If the BobsCNC kit is purchased with Vectric software, the refunded amount will reduced by the retail price of the Vectric software. Please contact Vectric for software transfer policies.

### **Technical Assembly**

BobsCNC does not guarantee the buyer’s ability to assemble, setup, or use our product(s). Since the quality of any project produced using the E3 is dependent upon its proper setup and the understanding of its operating parameters, BobsCNC does not guarantee the quality of the parts manufactured using the E3.

| <b><u>Miscellaneous Parts List</u></b> | <b><i>Quantity</i></b> |
|--|------------------------|
| M3x 10                                 | 16                     |
| M4x16                                  | 200                    |
| M4 Nuts                                | 200                    |
| M4x25                                  | 7                      |
| M6x25                                  | 16                     |
| M6 Nuts                                | 16                     |
| SG20 U Bearings                        | 16                     |
| M6 Hardened Washers                    | 36                     |
| M5X25                                  | 3                      |
| M5 nuts                                | 6                      |
| M5 washer                              | 6                      |
| Flanged bearings (F625Z)               | 6                      |
| M2.5 x 16 screws                       | 6                      |
| M2.5 nuts                              | 6                      |
| Wing nuts (1/4-20)                     | 8                      |
| 1/4-20 Screws 2"                       | 8                      |
| GT2 Pulleys                            | 3                      |
| GT2 belt (long)                        | 1                      |
| GT2 belt (short)                       | 2                      |
| 5/16-18 Threaded Rod                   | 1                      |
| 5/16 washer                            | 2                      |
| 5/16-18 Coupler Nut                    | 1                      |
| 5/16 nuts                              | 2                      |
| Large Nylon Zip Tie                    | 1                      |
| 8x22x7 bearing                         | 1                      |
| aluminum coupler 5 x 8                 | 1                      |
| 2 mm Allen Wrench                      | 1                      |
| 1.5 mm Allen Wrench                    |                        |
| 5/16" bearing steel rails (long)       | 4                      |
| 5/16" bearing steel rails (medium)     | 2                      |
| 5/16" bearing steel rails (short)      | 2                      |
| MDF Bed (17 x 24) with inserts         | 1                      |
| USB cable                              | 1                      |
| Small nylon zip ties                   | 30                     |
| Spiral wire wrap (6')                  | 1                      |
| Home switches                          | 3                      |
| DeWalt DW660 Spindle                   | 1                      |
| Arduino Uno                            | 1                      |
| Grbl shield                            | 1                      |
| Stepper motors                         | 4                      |
| Stepper motor drivers                  | 4                      |
| Power supply with cord                 | 1                      |
|  |                        |

# Diagrams for Plywood Components

## Frame Parts

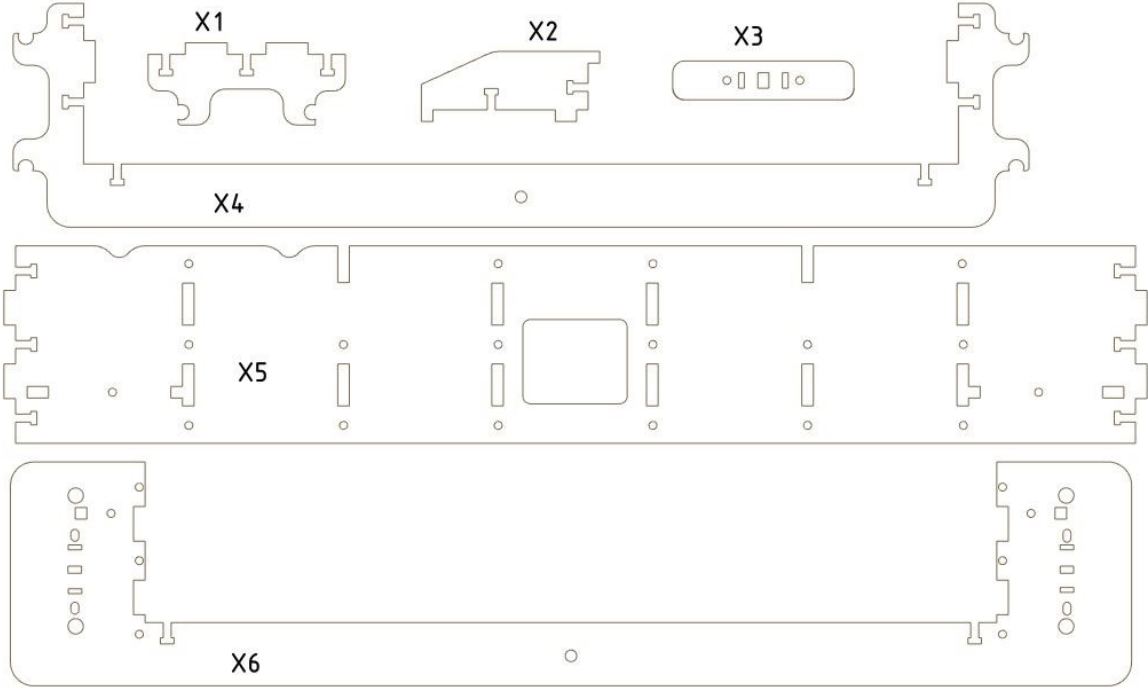

| Part # | Qty | Component           |
|--------|-----|---------------------|
| X1     | 8   | X Rail Supports     |
| X2     | 4   | Frame Corner Braces |
| X3     | 3   | X Rail Stop         |
| X4     | 2   | Mid Frame Supports  |
| X5     | 2   | Frame Side Supports |
| X6     | 2   | Frame End Supports  |

## Diagrams for Plywood Components

### Gantry Parts

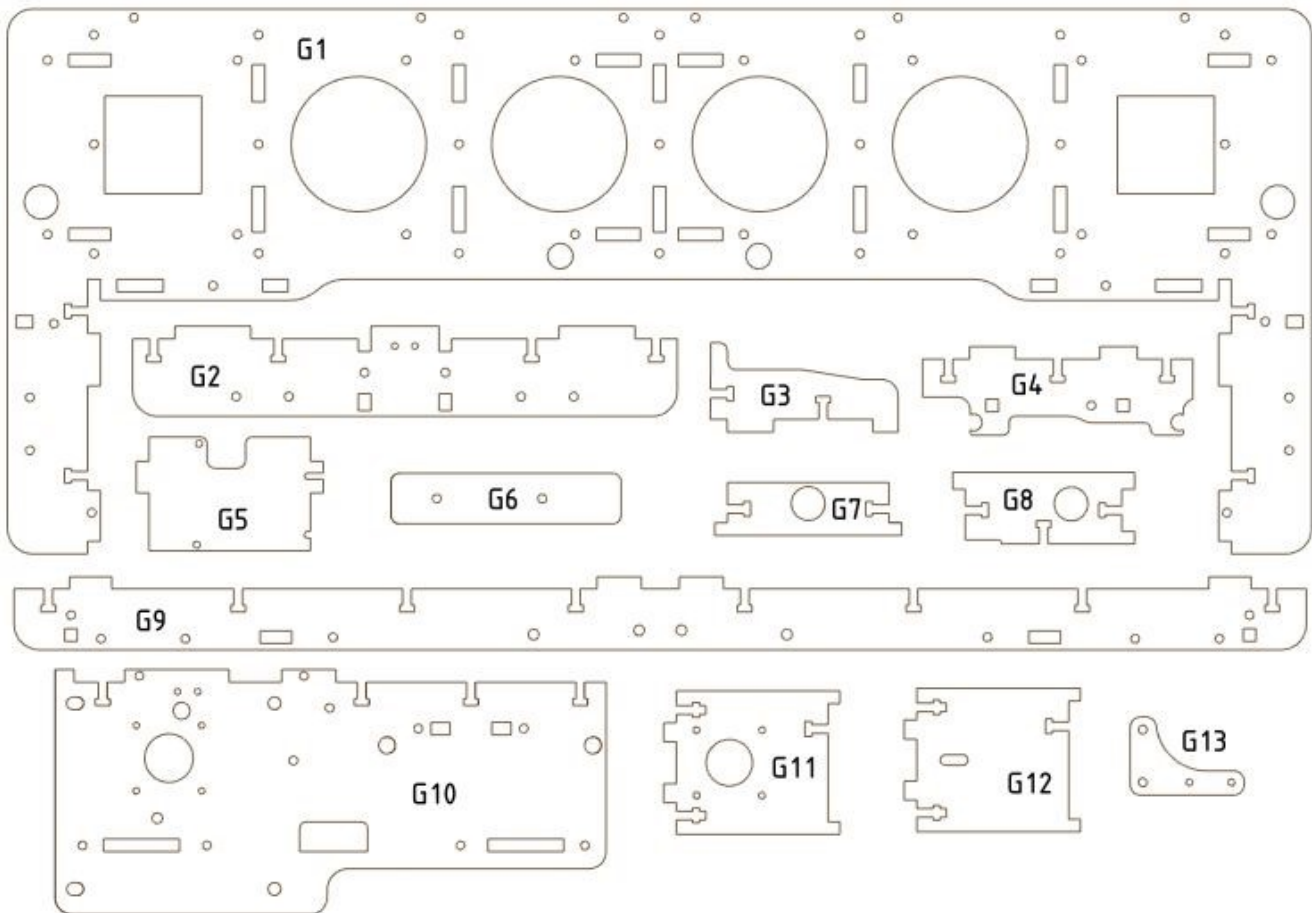

| Part #     | Qty      | Component                  |
|------------|----------|----------------------------|
| <b>G1</b>  | <b>1</b> | <b>Gantry Frame</b>        |
| <b>G2</b>  | <b>2</b> | <b>Gantry Side Support</b> |
| <b>G3</b>  | <b>2</b> | <b>Gantry Corner Brace</b> |
| <b>G4</b>  | <b>5</b> | <b>Y Rail Support</b>      |
| <b>G5</b>  | <b>1</b> | <b>Controller Mount</b>    |
| <b>G6</b>  | <b>2</b> | <b>Y Rail Stop</b>         |
| <b>G7</b>  | <b>2</b> | <b>Gantry Back Brace</b>   |
| <b>G8</b>  | <b>2</b> | <b>Gantry Side Brace</b>   |
| <b>G9</b>  | <b>2</b> | <b>Gantry Back Support</b> |
| <b>G10</b> | <b>2</b> | <b>Gantry Side Frame</b>   |

| Part #     | Qty      | Component                    |
|------------|----------|------------------------------|
| <b>G11</b> | <b>1</b> | <b>Y Stepper Motor Mount</b> |
| <b>G12</b> | <b>1</b> | <b>Y Belt Idler Mount</b>    |
| <b>G13</b> | <b>2</b> | <b>Cable Mount</b>           |



## Diagrams for Plywood Components

### Y Carriage Parts

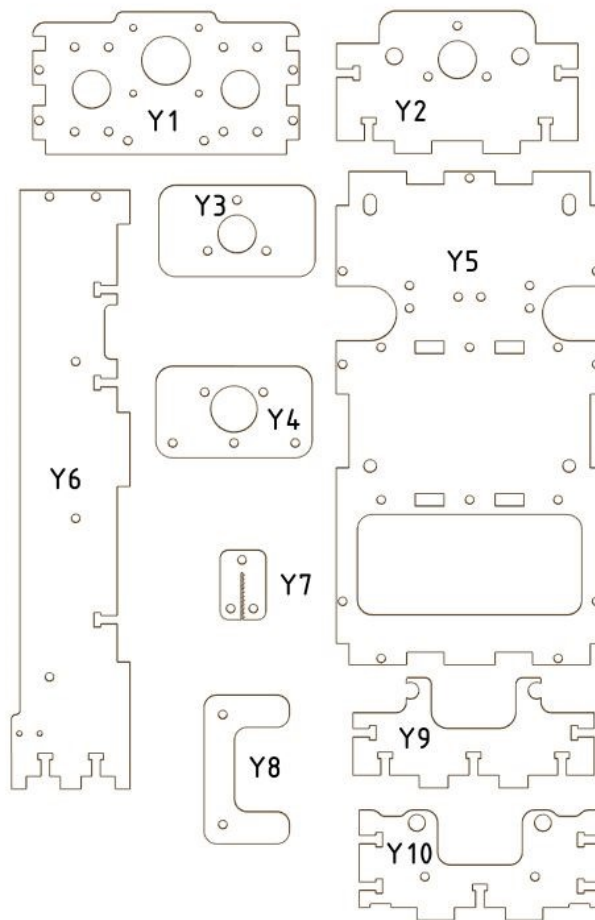

| Part # | Qty | Component                 |
|--------|-----|---------------------------|
| Y1     | 1   | Z Stepper Motor Mount     |
| Y2     | 1   | Bearing Bottom Plate      |
| Y3     | 1   | Bearing Top Plate         |
| Y4     | 1   | Bearing Middle Plate      |
| Y5     | 1   | Y Carriage Frame          |
| Y6     | 2   | Y Carriage Side Supports  |
| Y7     | 2   | Belt Retainer             |
| Y8     | 2   | Z-Rail Stop               |
| Y9     | 2   | Z-Rail Supports           |
| Y10    | 1   | Y Carriage Bottom Support |

## Diagrams for Plywood Components

### Z Parts

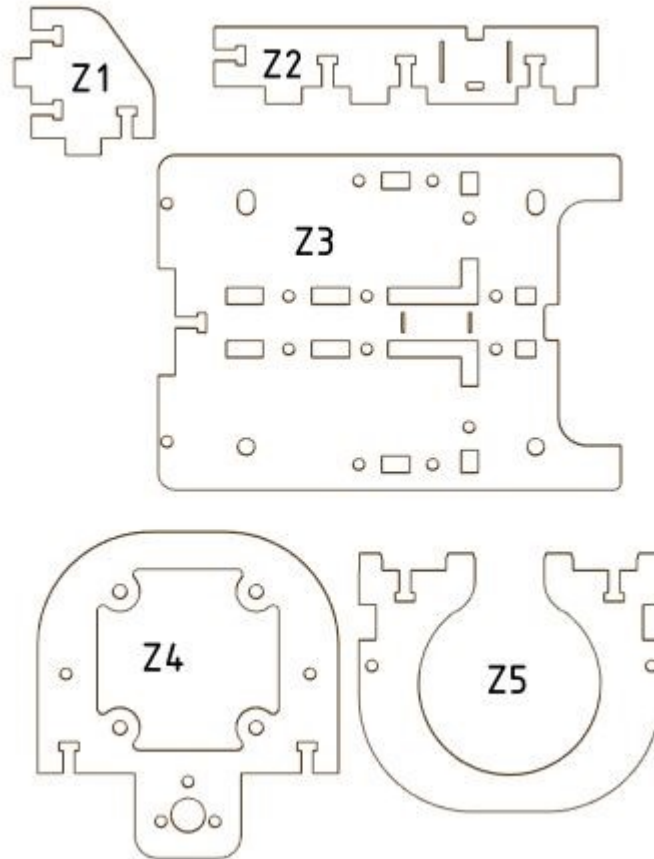

| Part # | Qty | Component              |
|--------|-----|------------------------|
| Z1     | 2   | Frame Mount Support    |
| Z2     | 2   | Z-Frame Support        |
| Z3     | 2   | Z Frame                |
| Z4     | 1   | Z-Spindle Bottom Mount |
| Z5     | 1   | Z-Spindle Top Mount    |

### Accessories

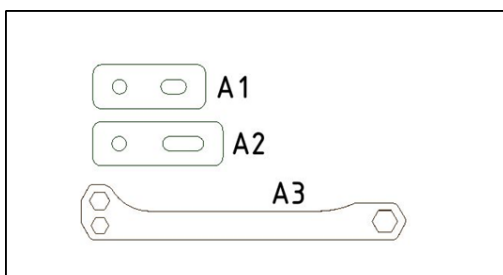

| Part # | Qty | Component   |
|--------|-----|-------------|
| A1     | 4   | Short Clamp |
| A2     | 4   | Long Clamp  |
| A3     | 1   | Wrench      |