

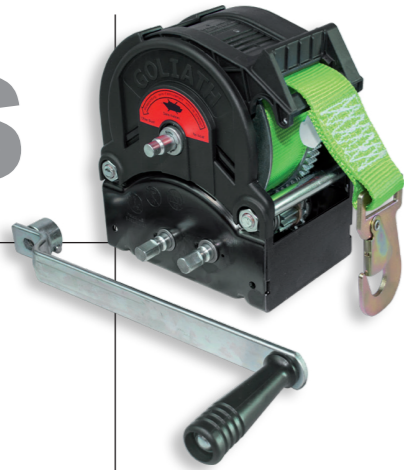

# Instructions

# TS



**Treuil pour remorque porte-bateau TS**  
**Boat trailer winch TS**  
**TS Bootstrailer Winde**  
**Argano per rimorchio porta imbarcazione TS**

PU03829  
 V201803

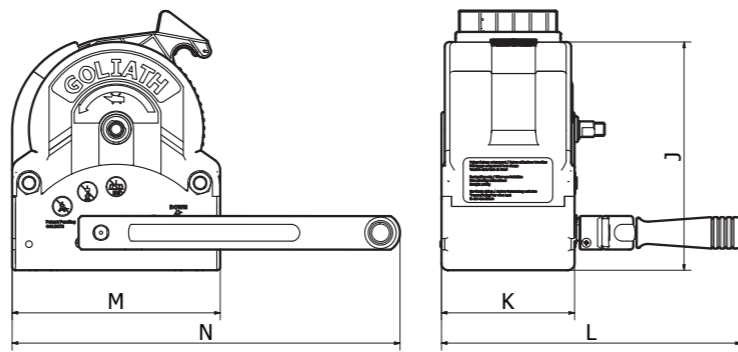
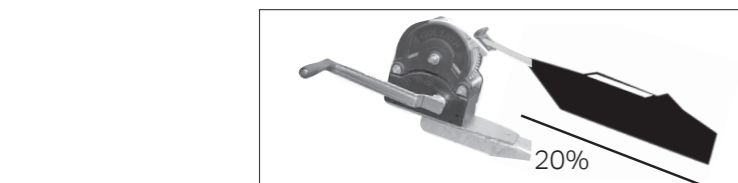
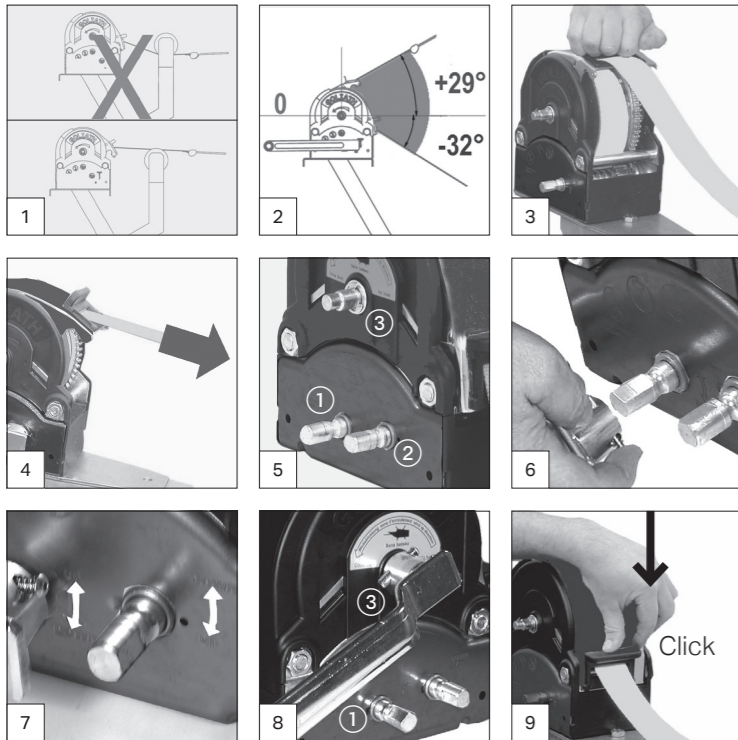

Fixing dimensions

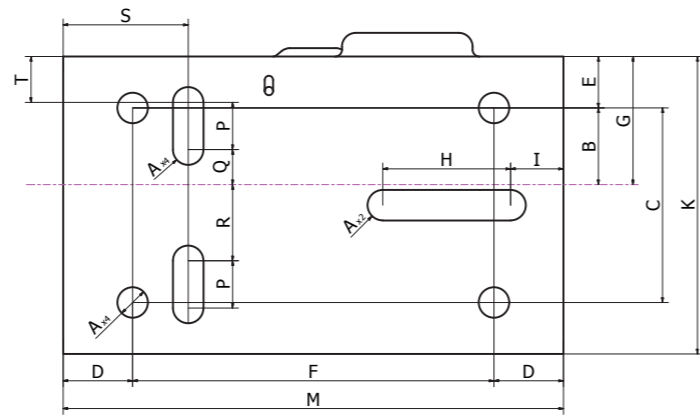

	TS700	TS800	TS900	TS1200	TS1600	TS2200	TS3000	PF56413
A	11	11	11	11	11	11	13	11
B	28,5	28,5	28,5	28,5	28,5	28,5	60,25	13
C	70	70	70	70	70	70	128	35
D	28	28	28	28	28	28	25	25
E	24,5	24,5	24,5	24,5	24,5	24,5	24,75	58,5
F	130	130	130	130	130	130	210	130
G	53	53	53	53	53	53	85	16
H	46	36	36	36	36	36	-	12
I	22	22	22	22	22	22	10,5	107
J	183	208	208	208	208	208	220,5	32
K	119	119	119	119	119	119	177,5	117
L	273	273	273	273	273	273	335,4	-
M	186	186	186	186	186	186	252	220
N	430	390	430	390	430	430	518,8	-
P	17	-	-	-	-	-	-	66
Q	13,5	-	-	-	-	-	-	20
R	26,5	-	-	-	-	-	-	-
S	48	-	-	-	-	-	-	-
T	22,5	-	-	-	-	-	-	-

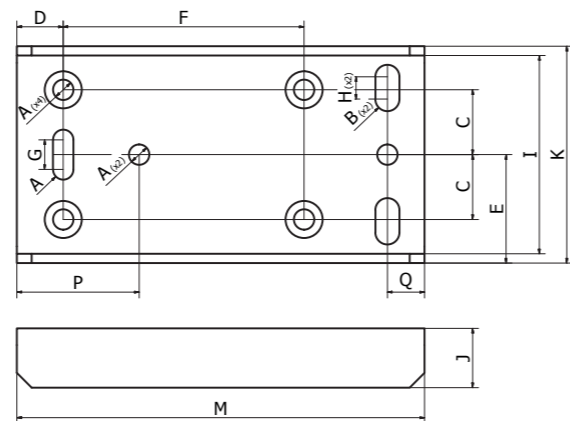

PF56413 - Adapting plate for tube mounting

## Use and maintenance of the TS winch

### 1. Preparation before launch and hauling operations.

- 1.1 Make sure nobody stands behind or on the boat. Check the correct strap position above the guide roll of the winch stand (fig.1) and secure a direct line pull between the winch and the boat. Verify if the angle between the strap and the fixing ground of the winch lies within prescribed limits (grey zone of fig.2).
- 1.2 Check the strap condition: verify that the strap is not damaged, knotted or tied and if it can move freely on its total length. Control the correct attachment of strap to the bow eye of the boat and if the hook is working properly.
- 1.3 Make sure the strap guide is in up position "load brake" (fig.3). Check the status of load brake by pulling on the strap until it is blocked (after max. 20 cm) by the security system (fig.4). If strap is not blocked do not use the winch.

### 2. Launch operation

- 2.1 Position handle on drive shaft 1 or 2 (fig.5) and lock it (fig.6). Shaft 3 only dedicated to fast up-winding of strap (under no load conditions).
- 2.2 Turn handle as indicated by the arrow (fig.7). During launch operation, keep your hand on the handle. The operation can be interrupted at any moment by stopping any action on the handle.
- 2.3 Never unwind the strap beyond the mark, printed about 40 cm before strap end.

### 3. Winding up the strap

- 3.1 For increased life of webbing strap wind up strap after each use.
- 3.2 Position handle on shaft 3 (fig.8). Caution: any action on shaft 3 to be performed WITHOUT load.
- 3.3 Wind up in direction indicated by the arrow (anti-clockwise). To avoid strap damage, make sure that strap does not grind in the water or on the ground, while winding it up.
- 3.4 Do not completely wind up the strap. Fix the hook on the trailer during transport. Take the handle off the winch.

### 4. Hauling operation

- 4.1 Take handle off the shaft and push strap guide in lower position until it is clipped on lower bar and brake is blocked (fig.9).
- 4.2 Pull off the webbing smoothly, without shocks and hook it to the bow eye of the boat. Make sure it is attached correctly and the locking lever of the hook is working properly. Verify that strap is not twisted, jammed or knotted, split or damaged.
- 4.3 Position the handle on drive shaft 1 or 2 (fig.5) and lock it there. Never use shaft 3 only dedicated for fast wind-up of strap under no load condition.
- 4.4 Turn handle in direction indicated by the arrow. The strap guide shall open up automatically. If it does not, push up the strap guide up manually and repeat test described in point 1.3.
- 4.5 During the hauling operation, you should hear a regular clicking sound indicating the proper operation of the winch. If you hear nothing, it is possible that the brake is not working. Turn the handle 2 or 3 times in the « up » direction to engage the brake. If you still do not hear the clicking sound after some turns, do not use the winch.
- 4.6 Keep a hand on the crank during the whole hauling operation. It is possible to interrupt the operation at any moment by stopping all action on the handle.
- 4.7 As soon as the boat is pulled on the trailer, secure it with the QuickFlex System. Do not depend on the winch to support or fix the boat on the trailer during the transport. Take the handle off the winch (fig.6).

### Winch maintenance

- Check webbing strap condition: if strap is split, cut, fold, the strap joint or the locking lever of the hook damaged or do not work properly, replace it before use. Strap replacement at beginning of each new season is recommended.
- Grease the gears at least once a year and more frequently if the winch is used intensively. To do so, do not disassemble the winch. Push the strap guide up, turn the drum and grease the gear structure with a brush. Use grease type molydal n°3790.
- Important: never oil or grease the brake and security system.**
- Keep the winch in good working order. Damaged or severely worn parts can cause incorrect operation or accidents. If winch is used in a professional environment, it has to be checked at least once a year by an authorized person. The results of this check have to be recorded in a maintenance booklet. Same procedure is recommended for winch checks if winch is used in private environments

### Spare parts

When replacing parts of the winch it is mandatory to use original spare parts, available at your authorized distributor. The use of all other parts can cause incorrect operation of winch and product liability, and manufacturer will therefore withdraw its product responsibility. Maintenance operations have to be performed by an authorized distributor. Spare parts: Table 1

TABLE 1	Sangle équipée Equipped strap	Fixation pour sangle Strap clamp Haltering Spannurt Fissaggio per cinghia	Bobine équipée Equipped drum strap guide Spule Spannurt Bobina cinghia	Guide sangle Strap guide Anleitung Spannurt Guida cinghia	Capot noir Black cover Schwarze Gehäuse Capot nero	Platine support Support plate Trägerplatte Piastra supporto	Cache noir Black cover Schwarze Hülle Tppo nero	Kit manivelle Handle kit Kit Handkurbel Kits manovella Kit manivela
	Reference	Details	x2	Standard	Standard	Standard	x2	Standard
TS700	-	-	-	PF56405	PF56424	-	-	PF75083
TS800	PF56022	Black - L=8m - W=48mm	-	PF56406	-	-	-	PF56410
TS900	PF56024	Yellow - L=8m - W=48mm	-	PF56407	-	-	-	PF56411
TS1200	PF56024	Yellow - L=8m - W=48mm	PF56020	PF56408	PF56420	PF56421	PF56413	PF56410
TS1600	PF56025	Green - L=8m - W=48mm	-	PF56409	-	-	-	-
TS2200	PF56025	Green - L=8m - W=48mm	-	PF56412	-	-	-	PF56411
TS3000	PF56427	Red - L=13m - W=48mm	-	-	-	-	-	-

TABLE 2

Treuilis sangle	Webbing strap winch	Gurtbandwinde	Argani cinghia	Cabrestantes cuerda	TS700	TS800	TS900	TS1200	TS1600	TS2200	TS3000
Référence (Sangle 50mm)	Item N° (Webbing strap 50mm)	Art.-Nr (Gurtband 50mm)	Referenza (Cinghia 50mm)	N° del artículo (Cuerda 50mm)	PF70700B	PF70800B	PF70900B	PF701200B	PF701600B	PF702200	PF703000
Capacité en charge roulante pente 20%	Rolling load capacity on 20% incline	Zugkraft, rollende Last bei 20% Steigung	Capacità carico rullante pendenza 20%	Capacidad de tracción 20% de inclinación	700 kg	800 kg	900 kg	1200 kg	1600 kg	2200 kg	3000 kg
Ø du moyeu de bobine	Drum Ø	Trommeldurchmesser	Ø del mozzo della bobina	Ø del tambor	16 mm	20 mm	20 mm	20 mm	20 mm	20 mm	27 mm
Longueur de sangle (possible)	Strap length (possible)	Gurtbandlänge (möglich)	Lunghezza cinghia (possibile)	Lagura del cuerdo (possible)	6,5 m	8 m	8 m	8 m	8 m	8 m	13 m
CRM sangle (préconisé)	MBL of webbing strap (recommended)	Bruchkraft Gurtband (empfohlen)	Caricamento di rottura del cinghia (raccomandato)	Carga de ruptura del cuerda (recomendado)	2 000 kg	2 000 kg	2 800 kg	2 800 kg	4 400 kg	4 400 kg	6 000 kg
Longueur de sangle	Strap length	Gurtbandlänge	Lunghezza cinghia	Lagura del cuerdo	6,5 m	8 m	8 m	8 m	8 m	8 m	13 m
CRM sangle	MBL of webbing strap	Bruchkraft Gurtband	Caricamento di rottura del cinghia	Carga de ruptura del cuerda	2 600 kg	2 600 kg	4 400 kg	4 400 kg	4 400 kg	4 400 kg	4 400 kg
Charge minimum de fonctionnement	Min. load for the brake function	Mindestlast für Bremsfunktion	Carico minimo di funzionamento	Carga mínima de funcionamiento del freno	10 kg	10 kg	10 kg	10 kg	10 kg	10 kg	10 kg
Rapport de réduction	Gear ratio	Untersetzung	Rapporto di riduzione	Relación de engranaje	1/3,5	1/3,5	1/4,85	1/4,85 & 1/9,71	1/4,85 & 1/9,71	1/4,85 & 1/9,71	1/10 & 1/21,77
Longueur manivelle	Crank handle length	Handkurbelslänge	Manovella lungo	Manivella longitudud	200 m	250 mm	290 mm	250 mm	290 mm	290 mm	290 mm
Masse du treuil	Weight	Gewicht, ca	Massa dell'argano	Peso neto	2,3 kg	6,1 kg	6,1 kg	6,4 kg	6,7 kg	6,7 kg	22,4 kg

## General security and mounting instructions for the TS winch

### Introduction and applications.

The winch is delivered complete with strap and hook. The winch is exclusively dedicated to launch and hauling operations of boat on trailers designed for these operations. The winch capacity reflects the boat weight, sliding on rollers with an incline of maximum 20% (fig.21). **Important: The more important the incline is, the heavier the load to be held by the winch will be. Do not use the winch on inclines (= the angle between the boat and water surface) higher than 20% or for loads heavier than the maximum load capacity indicated on the winch.**

### General security instructions.

- The disrespect of these instructions may cause accidents. Check the winch before each use. Do not use the winch if you have a doubt on its proper operation. See also user instructions at the back.
- Important, it is forbidden:**
  - to lift, support or transport people.
  - for people to stand under, behind or on the boat.
  - to lift a load.
  - to hold the boat with the winch longer than the time necessary to move the boat on or off the trailer.
  - to depend on winch to secure the boat during the transport.
- Never unwind the strap completely. Keep a minimum of 2 layers on winch drum (limit marked by a line on the strap).
- Never wind up the strap in counter direction against normal drum direction (= do not turn handle in direction "down" indicated on the winch by an arrow, when strap is completely unwound). In this case the load brake will not be operating. The winch should not be used by children or people unfamiliar with operating mode of the winch. Use only the handle designed for this application. Do not operate the winch with a motor. Never disassemble or modify the winch.
- Never exceed the loads indicated on the winch (Table 2).
- Never operate the winch with damaged webbing strap (see also "Winch maintenance" at the back).

### Winch mounting on trailers

- Attention: The winch is a security feature that should always be installed by an authorized professional.**
- 1. Minimum dimension of winch mounting support has to be 150 x 200 mm.
- 2. Use 4 hexagonal screws type M10 (TS3000 : M12), minimum class 8.8, with flat washers corresponding to NF E 27.611.
- 3. Torque of screws should be 4,8 daN.m.
- 4. To avoid a deformation of winch body when fixing the screws, make sure that winch support and the winch's fixing holes are lined up.
- 5. To guarantee maximum stability the winch has to be fixed on four points. Nevertheless TS700 winches can also be fixed on three points. The TS 2200 is already equipped with an assembly plate when delivered to position when setting up the winch.
- 6. Make sure that the level of the winch mounting support does not affect the proper functioning of the security system (especially with regard to the guiding rolls and the strap).
- 7. The strap has to be positioned on top of the guide roll of the winch stand (fig.1).
- 8. Respect the limits of the angle between the strap attached to the boat and the fixing plate of the winch (fig.2).



