



Tiger



Hand Winch Operating Instructions

Model :HW-2000 Capacity : 2000 Lbs (900kg)

WARNING

This winch should not be installed, operated or maintained by any person who has not read all the contents of these General Instructions. Failure to read and comply with these instruction or any one of the limitation noted herein can result in serious bodily injury and / or property damage.

(A) USE

Lifting of the load must happen by rotating the crank clockwise. When releasing the crank, the load remains suspended. The descent of the load must happen by rotating the crank counterclockwise.

(B) WARNINGS FOR THE SAFETY OF YOURSELF AND OF OTHER PEOPLE

- The use of the winch is not allowed for lifting people or for lifting things over areas where people may loiter or pass by.
- Do not lift any load when the rope is completely unrolled.
Make sure that there are three complete rope coils rolled on the drum.
- Use the winch only by hand and with the crank 195 mm long included in the equipment.
In case it is difficult to rotate the crank with only one hand, must probably the maximum capacity had been exceeded.
- The winch must not be kept under continuous loading.

(C) GREASING

It is advisable to lubricate frequently the holes guiding the shafts and the drum hub, and to grease the teeth of the two gear and of the thread of the crank shaft.

If installed in the open, it must be protected from dust, from dirt, rain, and should be more often checked and lubricated.

(D) FIXING OF ROPE TO DRUM:

① One Way Use

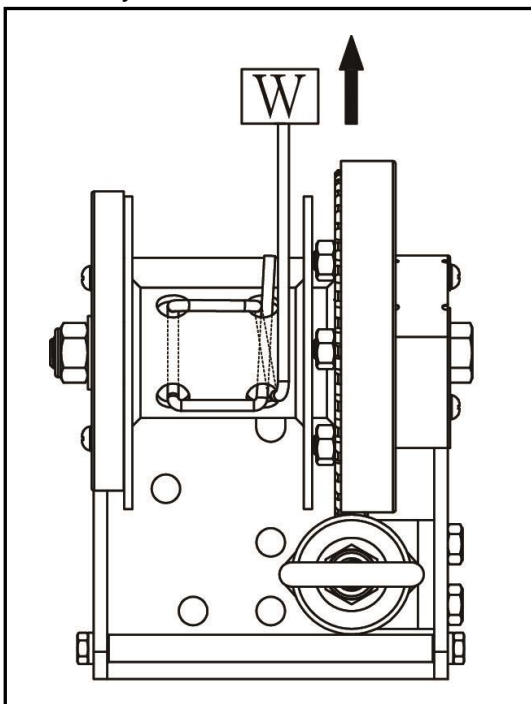

② Two Ways Use

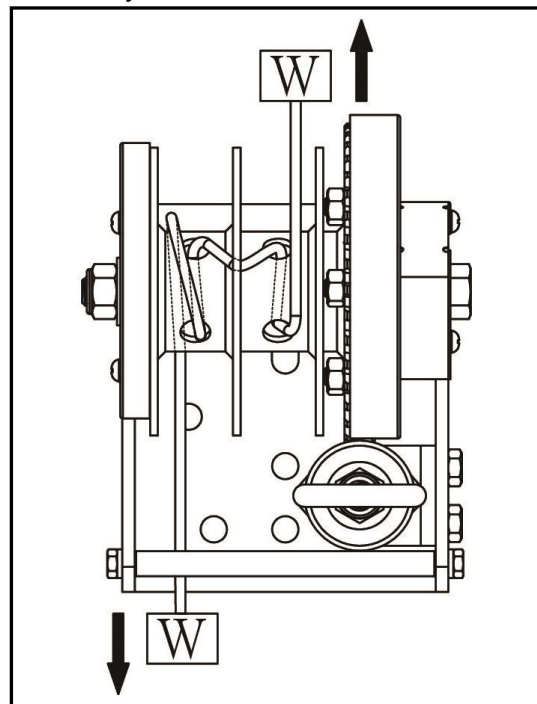

(E) TECHNICAL INFORMATION:

- Capacity : One way use: 1000 Lbs (450kg)
Two ways use: 2000 Lbs (900kg)
- Lift Per Crank Rotation : 7.5mm
- Hand Force Required : 10 Lbs (4.5kg)
- Gear Ratio : 41:1
- Hub Diameter : \varnothing 48mm
- Handle Length : 190 mm
- Rope Storage Capacity : Cable Diameter 4.8mm,
storage : per side 8.8 meter , two side 17.6 meter
- Unit Weight (with handle) : 5.84kg
- Unit Weight (with Loop) : 5.60kg

(F) EXPLODED VIEW & PARTS LIST:

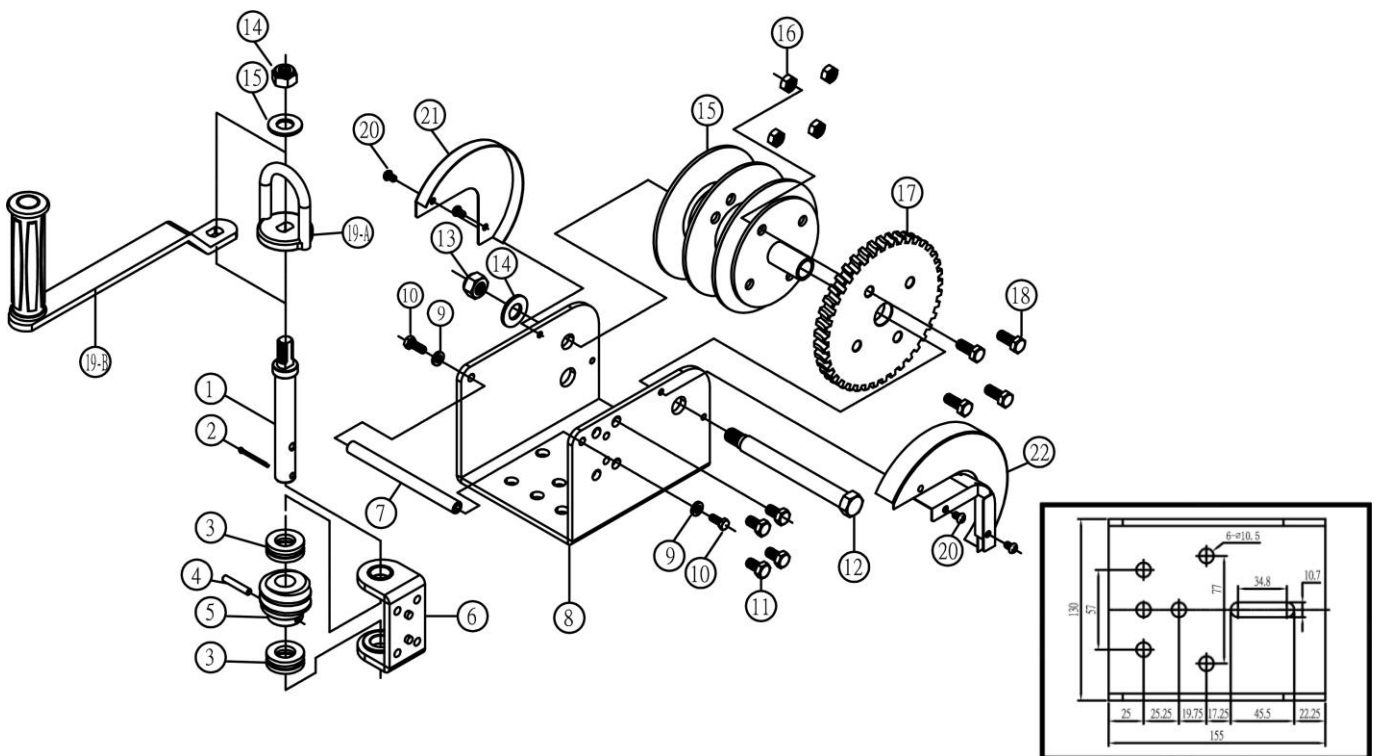

REF.NO.	PART. NO.	PART NAME	QTY.	REF.NO.	PART. NO.	PART NAME	QTY.
1	H-1	Worm Gear Shaft	1	13	H-13	Nut	2
2	H-2	Cutter Pin	1	14	H-14	Washer	2
3	H-3	Ball Bearing	2	15	H-15	Winch Reel	1
4	H-4	Spring Pin	1	16	H-16	Nut	4
5	H-5	Worm Gear	1	17	H-17	Reel Gear	1
6	H-6	Worm Gear Base	1	18	H-18	Screw	4
7	H-7	Strength Bolt	1	※19-A	H-19A	Loop	1
8	H-8	Winch Frame	1	※19-B	H-19B	Handle	1
9	H-9	Spring Washer	2	20	H-20	Screw	4
10	H-10	Screw	2	21	H-21	Reel Cover	1
11	H-11	Screw	4	22	H-22	Gear Cover	1
12	H-12	Reel Bolt	1				

※Optional Part