



ZENCRATE

HOLISTIC REMEDY • ANXIETY RELIEF • HAPPY DOGS



Your ZenGuide

Rev.2 May 21st 2018

Table of Contents

Unpack Your ZenCrate	3
Package Contents.....	3
Assembly	4
Download the ZenCrate App.....	10
iPhone, iPad and iPod touch	10
Android	15
Power Supply.....	19
Service and Support	19
Limited Warranty.....	19
Frequently Asked Questions (FAQs)	19
Company Information.....	20
FCC Warning Statement.....	20



Unpack your ZenCrate

Congratulations! Your dog now owns the most advanced anti-anxiety dog crate! The ZenCrate is super easy to assemble and will take you no more than 5 to 10 minutes to put together.

Package Contents

Your ZenCrate will arrive in 2 separate packages and 3 if you purchased the waterproof memory foam mattress with the following contents: 7 wooden panels (all labeled in *figure 1*), and 1 power supply in a small white box (*figure 1d*). If you ordered the camera add-on it will arrive to you already attached to the electronics panel. If you ordered the memory foam mattress you will have 1 vacuum sealed dog bed (*figure 1a*), 1 waterproof bed liner (*figure 1b*), 1 bed cover (*figure 1c*) Make sure you have plenty of room to assemble your ZenCrate and lay the 7 wooden panels out on the floor, matching up **each number**, as shown in *Figure 1* to ensure you have all the panels.

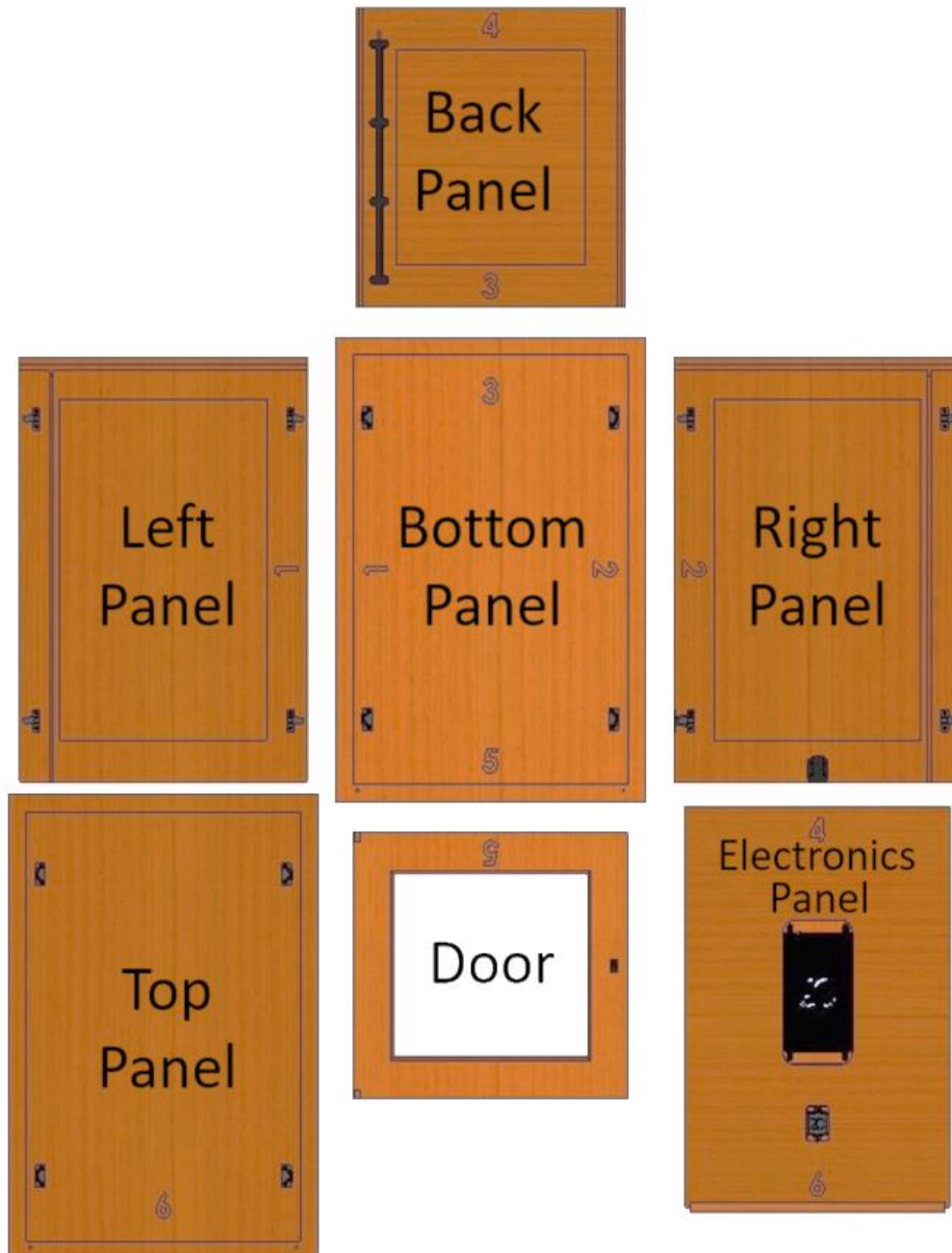

Left

Figure 1

Right



Figure 1a

Figure 1b

Figure 1c

Figure 1d

Assembly – No tools needed

Place all seven (7) panels on the floor as shown in *Figure 1*. We recommend assembling with two people for ease and safety.

Step 1) Left Panel – Align the **number 1** on the left panel with the **number 1** on the bottom panel. With the bottom panel laying on the floor, insert the side panel so the black tabs & numbers line up with each other. Push down firmly until the tabs click into the latches – as shown in *figure 2* below.

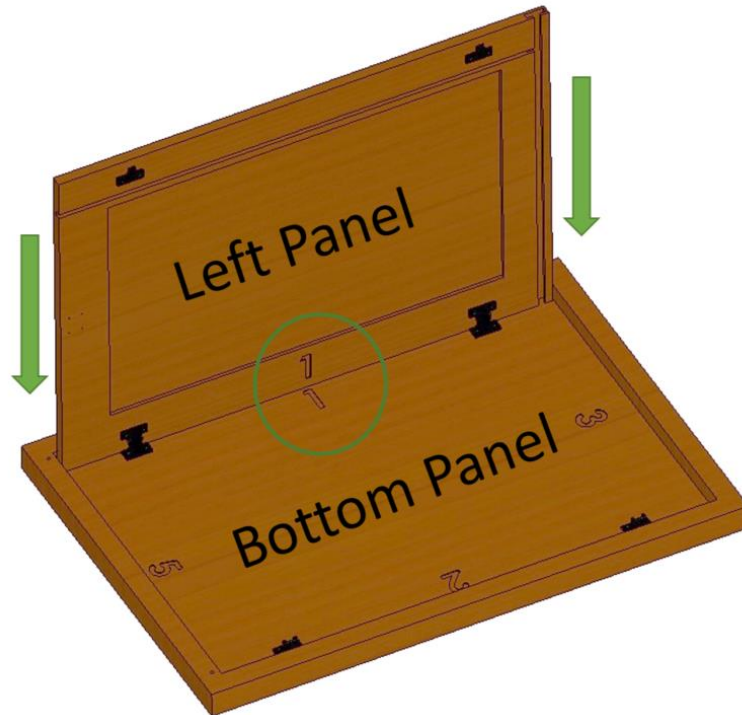

Figure 2

Step 2) Right Panel – Align the **number 2** on the right panel with the **number 2** on the bottom panel. With the bottom panel laying on the floor, insert the side panel so the black tabs & numbers line up with each other.

Push down firmly until the tabs click into the latches – as shown in *figure 3*.

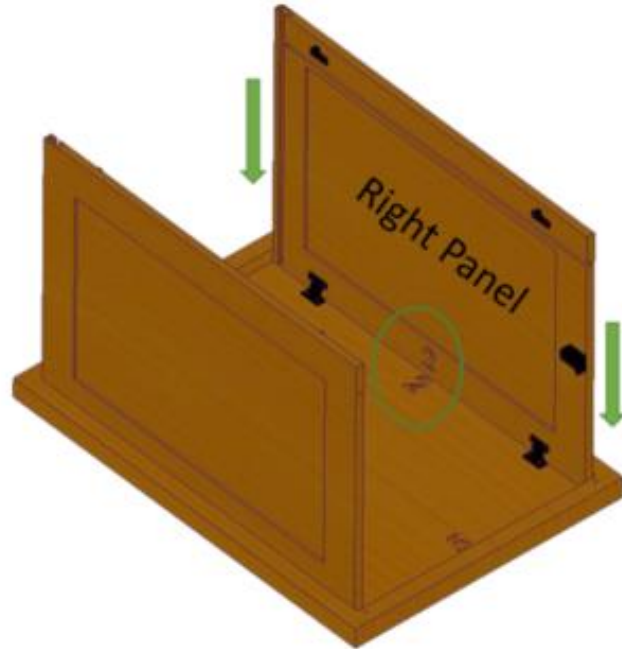

Figure 3

Step 3) Back Panel – Align the **number 3** on the back panel with the **number 3** on the bottom panel. Slide the back panel down along the two grooves of the left and right panels, making sure that the numbers line up – as shown in *figures 4 and 5*. Drape the black cord over the top of the back panel as we will use this cord in **step 4a** – shown in *figure 4*.



Figure 4

Figure 5

Step 4) Electronics Panel – With the plastic “ZC” electronics box facing up, slide it into the grooves of the left & right panels making sure that the **number 4** on the electronics panel lines up with the **number 4** on the back panel – as shown in *figures 6 and 7*. Ensure the electronics cable is draped over the top of the back panel as instructed in **step 3**. Push the panel firmly all the way to the back of the ZenCrate.

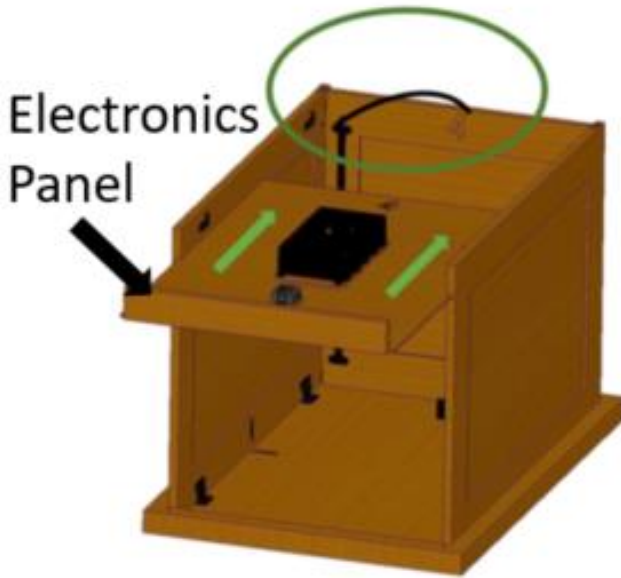

Figure 6

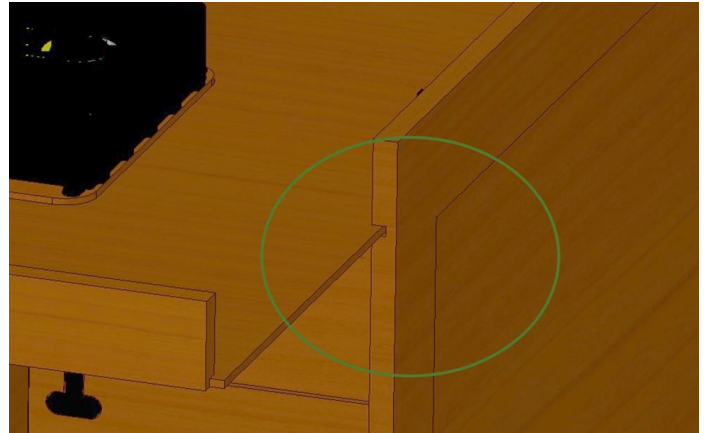

Figure 7

Step 4a) Electronics Cable - Connect the electronics cable that you draped over the back panel to the small power socket on the plastic electronic box – as shown in *figures 8 and 9*.



Figure 8

Figure 9

Step 4b) Optional Camera add on – The camera is the smaller of the two plastic boxes on this panel. Connect the camera to either USB port on the larger plastic box – as shown in *figure 10*.



Figure 10

Step 4c) On/Off (I/O) – Turn the I/O switch to the “I” position – as shown in *figure 11*.



Figure 11

Step 5) Door Panel – Align the **number 5** on the door panel with the **number 5** on the bottom panel – as shown in *figure 12*. The door panel has two metal pins on the top and bottom. Place the bottom pin (this will be on the same side as the **number 5** on the door) into the hole on the left side of the floor panel – as shown in *figure 12*. Let the door rest against the crate momentarily.



Figure 12

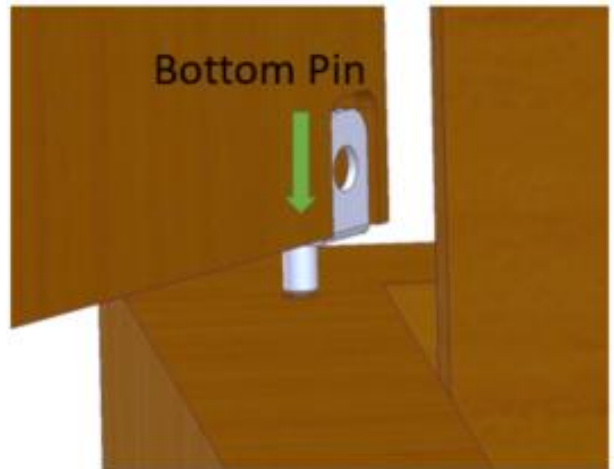

Figure 13

Step 5a) Door Panel latch – Attached to the door there is a small male end that will latch into the female receptacle on the right side panel. The two will need to be lined up together and you can gently push the male end in until it clicks, once clicked in the door will be secure – as shown in *figure 14*.

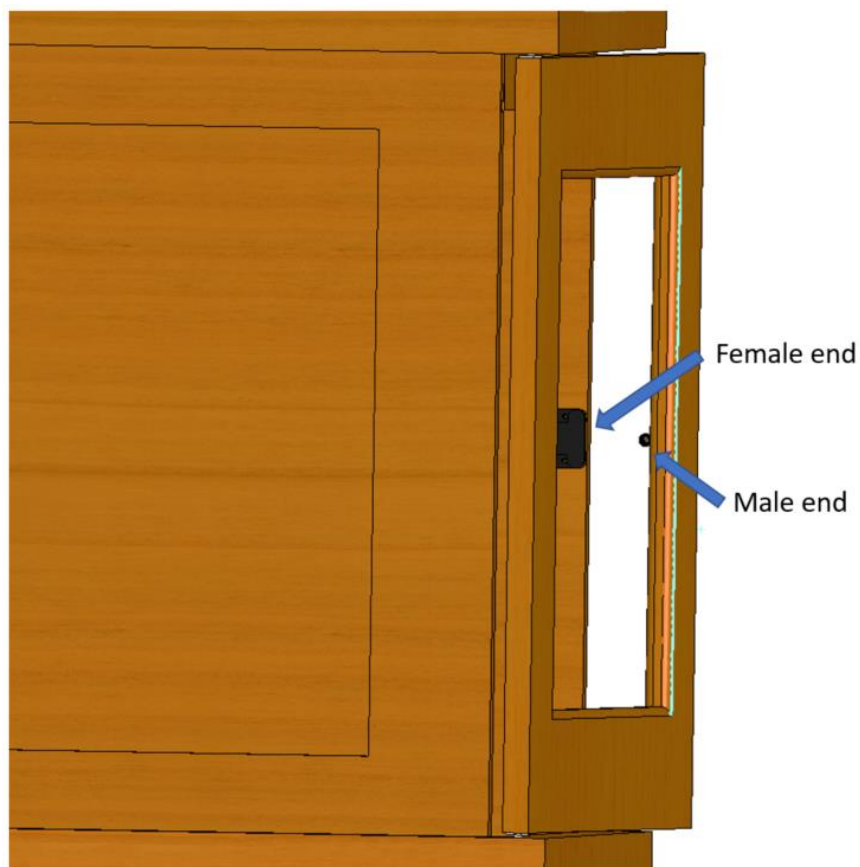

Figure 14

Step 6) Roof Panel – Align the **number 6** on the top panel with the **number 6** on the electronics panel. Then align the four (4) corners of the top panel with the four exposed black tabs on the left and right side panels – as shown in *figure 16*. The top panel will need to be gently pushed downward until the roof panel can also align with the metal pin on the door – shown in *figure 17*. This pin will slide into the small hole on the bottom face of the top panel.

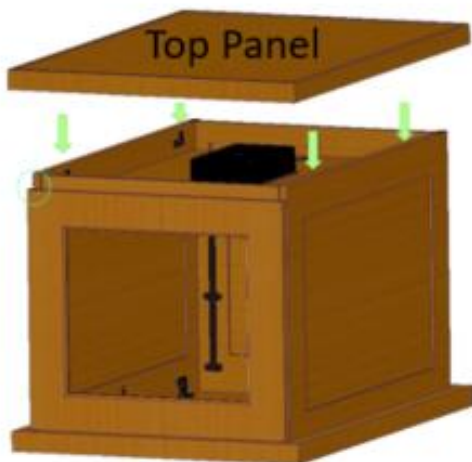

Figure 15

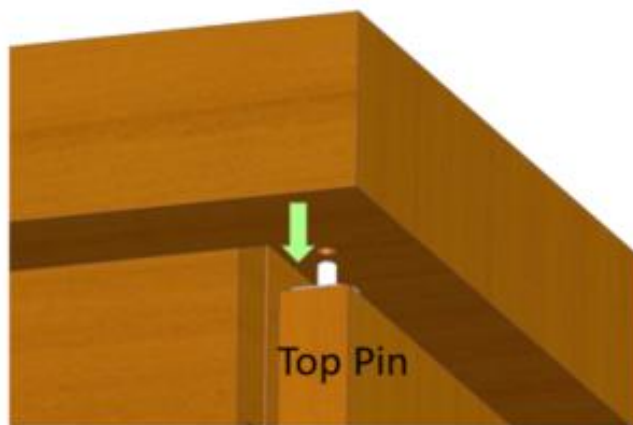

Figure 16

Step 7) Power – Unpack the external power cord from figure 1d. One end of this will plug into a wall outlet and the other end is a circular male end that will plug into the female barrel jack located on the back panel – as shown in *figure 17*.



Figure 17



Download the ZenCrate App

For iPhone, iPad and iPod Touch Users

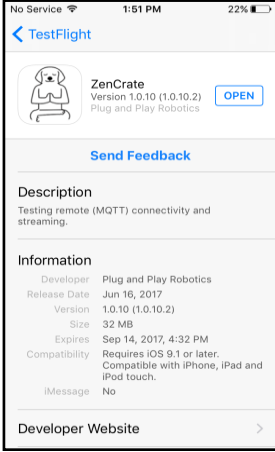
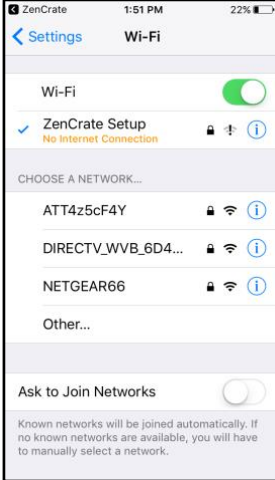

Be sure the ZenCrate is plugged in to a wall outlet and is turned on.

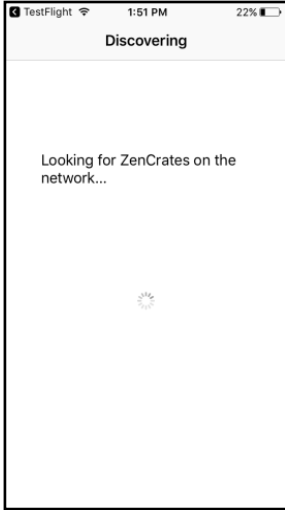
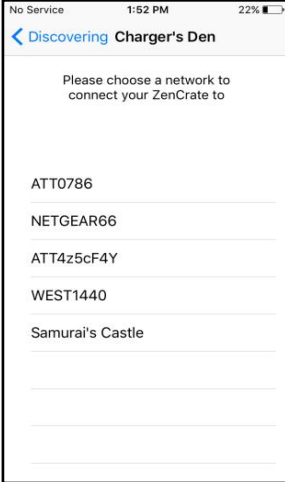
- a. Go to the App Store and download the “ZenCrate” app. Your device will discover the ZenCrate on the network.

Step	Action	Result
1	<p>Please Note:</p> <p>The ZenCrate app requires iOS 9.1 or later and is compatible with iPhone, iPad and iPod touch.</p> <p>*Please note the ZenCrate will not support WEP Security only WPA/WPA2 and 2.4GHz frequency when connecting to your home router network.</p>	
2	<p>Use your iPhone Settings application to connect to the ‘ZenCrate Setup’ network with password ‘zencrate’. Note the message will show ‘No Internet Connection’ when connected to the ZenCrate Setup network.</p>	

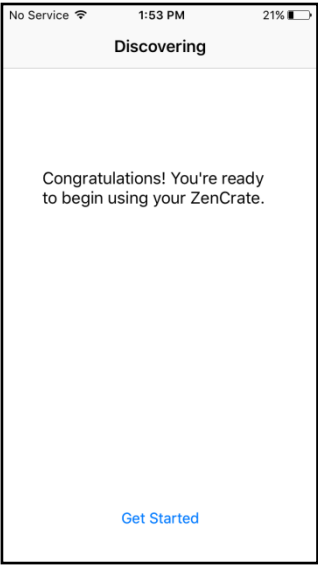
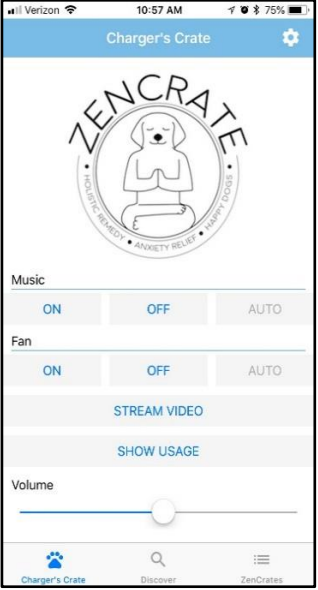
<p>3</p>	<p>Open the ZenCrate app and your device will begin searching for a ZenCrate on the network.</p> <p>*Please Note if the ZenCrate is not found the first time it may have timed out and try discovering again.</p>	
<p>4</p>	<p>Choose your Wi-Fi network and enter your personal Wi-Fi password at this time.</p>	
<p>5</p>	<p>Please wait while the ZenCrate is setting up on the network.</p>	

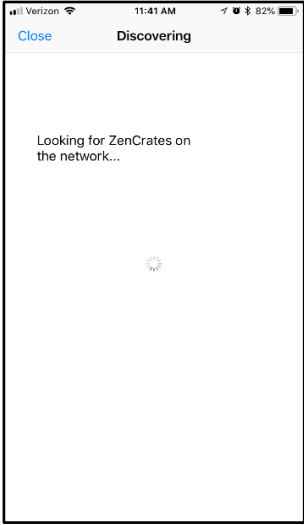
<p>6</p>	<p>Your device has discovered your ZenCrate and added it to your home network.</p> <p>*If you get an error message or no ZenCrates detected check and make sure your password for your router was entered correct as well as checking your router settings and confirm it is set to WPA/WPA2 security and 2.4GHz frequency. (If you do not know how to log into your router you may need to call your internet provider and they can do it for you. If your system was set to 5.0GHz you can change back after the ZenCrate is connected to your home network)</p>	
<p>7</p>	<p>*Whatever option is greyed out is the selection your device is set to.</p> <p>ON indicates the ZenCrate is on and functioning.</p> <p>OFF Indicates your ZenCrate is off and is NOT functioning.</p> <p>AUTO indicates your ZenCrate will activate whenever your pet enters the ZenCrate.</p> <p>STREAM VIDEO is for purchased optional camera only.</p> <p>SHOW USAGE shows you how often your pet enters the ZenCrate.</p> <p>Volume is adjustable with the slide bar.</p> <p>Note: The Zen Music will stop when your pet exits the ZenCrate when set to AUTO. Again, your selection will be greyed out as seen in picture.</p> <p>*Gear wheel in the top right-hand corner will drop down and give you options to select Settings or Notifications</p> <p>To Add another crate hit the Discover icon in the bottom middle of the screen and it will start searching for other crates that are turned on.</p>	

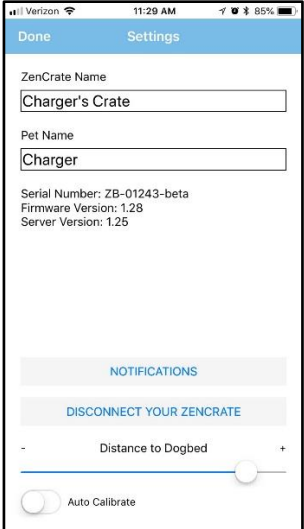
	<p>To manage your crates or change crates you are currently connected to, select the button in the bottom right corner of the screen that says ZenCrates. You will then see all your crates listed and select which crate you would like to view.</p>	
<p>8</p>	<p>Show Usage</p> <p>This screen shows you how much time your pet spends in your ZenCrate. The bars indicate the number of hours and minutes as well as the days of the week.</p> <p>Select Done to go back to the Main Screen.</p>	
<p>9</p>	<p>Settings</p> <p>Select 'Disconnect your ZenCrate' to disconnect your ZenCrate from your home network.</p> <p>Any server or firmware updates you need to perform on the crate will show up in this screen and show perform update button above notifications, but you will also get an alert when you first open the ZenCrate App when they are available to you.</p>	

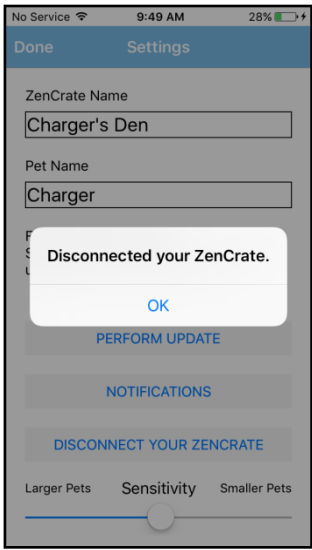

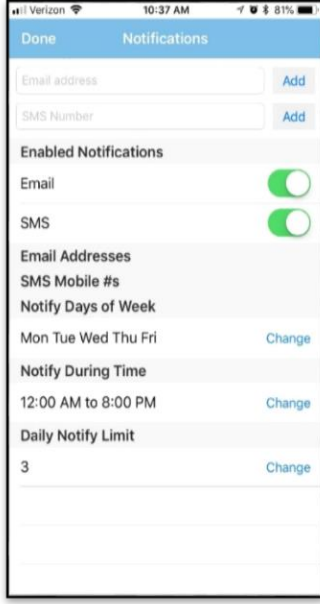
10	<p>This screen indicates that your ZenCrate has been disconnected from your home network.</p> <p>Select OK to return to the previous screen.</p>	
----	---	--

11	<p style="text-align: center;">Notifications</p> <p>Email address Add – allows you to enter an email address to your ZenCrate notifications.</p> <p>SMS Number Add – allows you to enter an SMS number to your ZenCrate notifications.</p> <p>Enable Notifications</p> <p>Email – slide to the right to enable email notifications.</p> <p>SMS – slide to the right to enable SMS notifications.</p> <p>Email Address – will list the email addresses you have entered.</p> <p>SMS Mobile #s – will list the SMS numbers you have entered.</p> <p>Notify Days of Week- Choose the days of the week you would like to be notified when your dog enters the crate.</p> <p>Notify During Time- You can set a time window of when you would like to be notified when your dog enters the crate.</p> <p>Daily Notify Limit- Set a limit to how many times a day you would like to be notified.</p> <p>Select Done when finished.</p>	
----	---	---



For Android Users

Be sure the ZenCrate is plugged in to a wall outlet and is turned on.

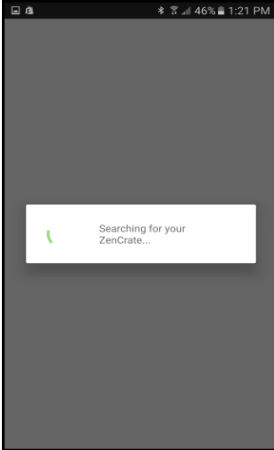
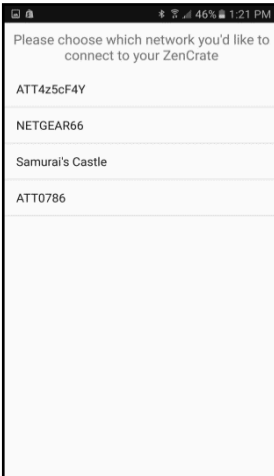
- a. Go to the Play Store and download the “ZenCrate” app.
- b. Your device will discover the ZenCrate on the network automatically.

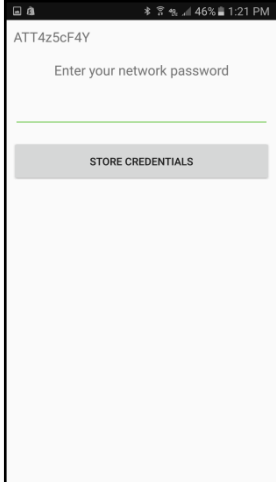
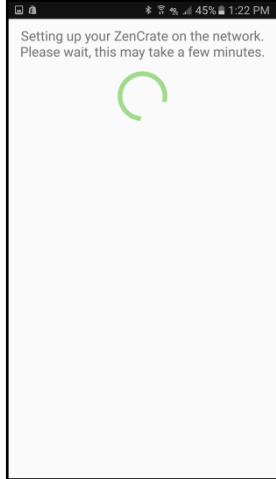
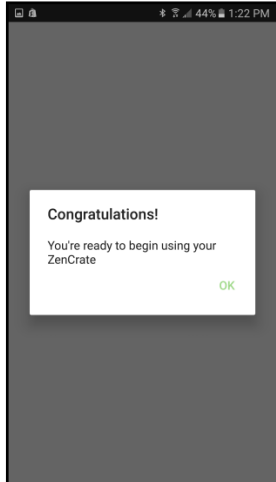
Step	Action	Result
1	<p>Tap the Wi-Fi  signal to connect to the ZenCrate app.</p> <p>*Please note the ZenCrate will not support WEP Security only WPA/WPA2 and 2.4GHz frequency.</p>	 <p>The screenshot shows the ZenCrate app interface. At the top, it says 'ZenCrate'. Below that, it says 'Connect ZenCrate to your Wi-Fi Network'. In the center, there is a large Wi-Fi symbol icon.</p>
2	<p>Your device will begin searching for a ZenCrate on the network.</p>	 <p>The screenshot shows a dark grey background with a white dialog box in the center. The dialog box contains a green Wi-Fi icon and the text 'Searching for your ZenCrate...'.</p>
3	<p>Choose your home network to connect to the ZenCrate.</p>	 <p>The screenshot shows the ZenCrate app interface with the text 'Please choose which network you'd like to connect to your ZenCrate'. Below this text is a list of four Wi-Fi networks: ATT4z5cF4Y, NETGEAR66, Samurai's Castle, and ATT0786.</p>

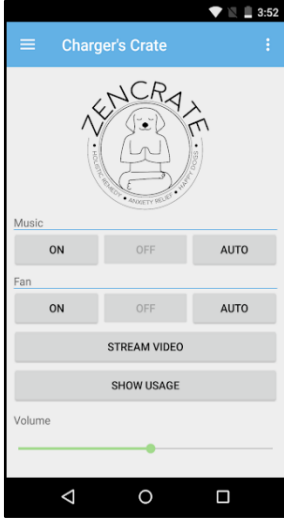
Step	Action	Result
4	Enter your home network's password.	
5	<p>It may take a few minutes to setup the ZenCrate with network credentials.</p> <p>*If you get an error message or no ZenCrates detected check and make sure your password for your router was entered correct as well as checking your router settings and confirm it is set to WPA/WPA2 security and 2.4GHz frequency. (If you do not know how to log into your router you may need to call your internet provider and they can do it for you. If your system was set to 5.0GHz you can change back after the ZenCrate is connected to your home network)</p>	
6	The ZenCrate app has connected and is ready to use.	

Step	Action	Result
7	<p>*Whatever option is greyed out is the selection your device is set to.</p> <p>ON indicates the ZenCrate is on and functioning.</p> <p>OFF Indicates your ZenCrate is off and is NOT functioning.</p> <p>AUTO indicates your ZenCrate will activate whenever your pet enters the ZenCrate.</p> <p>STREAM VIDEO is for purchased optional camera only.</p> <p>SHOW USAGE shows you how often your pet enters the ZenCrate.</p> <p>Volume is adjustable with the slide bar.</p> <p>Note: The Zen Music will stop when your pet exits the ZenCrate when set to AUTO. Again, your selection will be greyed out as seen in picture.</p> <p>To Add another crate hit the Discover icon in the bottom middle of the screen and it will start searching for other crates that are turned on.</p>	
8	<p>Show Usage</p> <p>This screen shows you how much time your pet spends in your ZenCrate. The bars indicate the number of hours/minutes as well as the date.</p>	

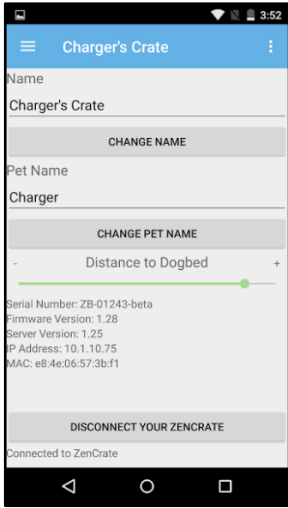
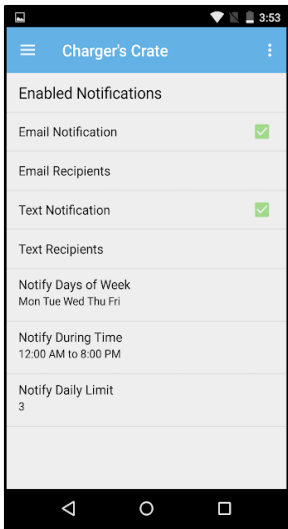
Step	Action	Result
9	<p>Settings</p> <p>Go to the three circle tab that looks like  in the upper right corner and hit Settings from the drop down and it will take you to the screen seen to the right.</p> <p>You will see ZenCrate Name and the Pet Name on your device's keypad as well as Distance to dog bed adjustment bar</p> <p>CHANGE NAME allows you to change the ZenCrate's name by clicking next to the preloaded name "Charger's Crate" and delete and place whatever you want your crate name to be and hit Change Name to save input.</p> <p>CHANGE PET NAME allows you to change your pet's name. Same as above delete preloaded name "Charger" and enter in your pet's name and hit Change Pet Name to save.</p> <p>Any server or firmware updates you need to perform on the crate will show up in this screen with an update available button above Disconnect Your ZenCrate, but you will also get an alert when you first open the ZenCrate App when they are first available to you.</p>	
9	<p>Notifications</p> <p>Email Notification – Click the box to enable email notifications.</p> <p>Email Recipients – Click and it will list the email addresses you have entered and be able to add.</p> <p>Text Notification – Click the box to enable text notifications.</p> <p>Text Recipients – Click and it will list the numbers you have entered and be able to add.</p> <p>Notify Days of Week- Choose the days of the week you would like to be notified when your dog enters the crate.</p> <p>Notify During Time- You can set a time window of when you would like to be notified when your dog enters the crate.</p> <p>Daily Notify Limit- Set a limit to how many times a day you would like to be notified.</p>	

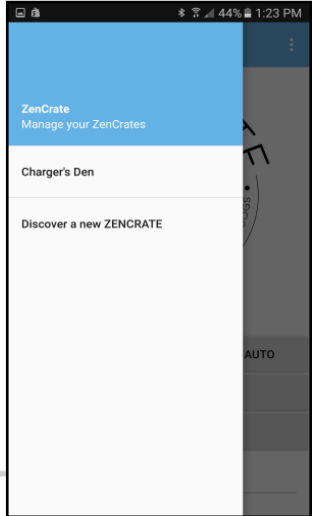
Step	Action	Result
10	Select Manage your ZenCrate to add or select a different ZenCrate.	

Power Supply: The ZenCrate is equipped with a power supply having a grounding wire with a grounding plug. Make sure you are within close proximity to a power outlet. Do not use outdoors or in damp areas. Do not alter or subject the power supply cord to damage or stress.

Service and Support: For more information about ZenCrate, please visit www.zendogcrate.com or contact support@zendogcrate.com

Limited Warranty: The ZenCrate has a 30-day warranty against defects in workmanship and materials. If within 30 days of purchase a defect occurs as a result of normal use, ZenCrate will repair the defect or exchange the product. Product failures caused by excessive or abusive conditions do not qualify for exchange. This warranty is available only to the original purchaser and is not transferrable. Please be advised that shipping costs will fall on the customer. Contact ZenCrate at support@zendogcrate.com.

Frequently Asked Questions (FAQS)

Does the ZenCrate come with a door to make the crate enclosed?

The ZenCrate comes with a door with an opening in the front for the dog to come and goes as it pleases. We will be releasing a gate insert as an add-on feature in the near future which will make the ZenCrate a closed crate.

Can I switch the direction of how the door opens?

Yes, we have designed the door to be able to open both ways. If you look closely on your ZenCrate you will notice that we have installed metal holes on both the left and right side of your crate so that you can flip your door around. You will need to use a Philips head screw driver to remove the female latching mechanism from the right side panel and screw it into the left side panel – we have made small pre-drilled holes so you can easily line this up. As always you can contact our customer service support for additional help if needed.

Is the ZenCrate safe?

We use all natural poplar hardwood and plywood, sourced directly from the U.S. that meet or exceed strict regulations, such as the California Air Resources Board or (CARB). Nearly all wood products made overseas or from cheap materials contain formaldehyde, which can be toxic for both humans and animals. Having tight control over these materials is just one reason we have decided to manufacture right here in the U.S.

What are the features of the orthopedic dog bed?

The orthopedic memory foam mattress has a waterproof liner that separates from the mattress for easy cleaning. Both the cover and liner have a zipper on one side. The mattress has 2 inches of full memory foam and 2 inches of support foam. The memory foam waterproof liner and mattress cover can be machine washed in cold water and line dry. Do not place the waterproof liner in the dryer.

Where does ZenCrate ship to?

Currently we only ship to US and Canada but have plans to expand our shipping destinations in the future. If you'd like to be updated as we release new developments and shipping locations for the ZenCrate please subscribe by signing up for our newsletter at www.zendogcrate.com.

What is your return policy?

ZenCrate 100% stands behind the engineering and production of each ZenCrate. With that said every dog is an individual and every dog is different. The ZenCrate is designed as a tool among a variety of modalities to reduce anxiety. Due to the personal nature of each ZenCrate, products cannot be returned in the event that it does not succeed in curing your dog's anxiety. We do not authorize returns based on your dog's usage of the ZenCrate. If a return is granted after contacting a customer service representative shipping will not be covered by ZenCrate for any returns made, this will fall onto the customer.

In the case of damaged, missing hardware or need help setting up your ZenCrate we are here to lend a paw, so please contact us via chat on our website, email support@zendogcrate.com or by phone at 954-635-2129 M-F 8am-5pm EST. If damage to the ZenCrate during shipping occurs, please take pictures of the box it came in before throwing shipping boxes away, so we can contact the shipping company as soon as possible and report it. **Please contact ZenCrate within 14 days of delivery to report any damaged pieces or defects due to shipping.** For a full detailed list of our return policy please refer to ZenDogCrate.com under Support for a more detailed list.

What do I do if my dog will not go into the ZenCrate?

ZenCrate was made for self-administered anxiety relief for your pets, but it may take some time for your dog to get used to his or her new ZenCrate. Begin with positive reinforcement or treats inside their crate until they get used to their new surroundings. For more information and tips on treating pet anxiety naturally, visit our blog at zendogcrate.com.

FCC Warning Statement

FCC WARNING STATEMENT

THIS DEVICE COMPLIES WITH PART 15 OF THE FCC RULES. OPERATION IS SUBJECT TO THE FOLLOWING TWO CONDITIONS: (1) THIS DEVICE MAY NOT CAUSE HARMFUL INTERFERENCE, AND (2) THIS DEVICE MUST ACCEPT ANY INTERFERENCE RECEIVED, INCLUDING INTERFERENCE THAT MAY CAUSE UNDESIRABLE OPERATION.

NOTE: THE GRANTEE IS NOT RESPONSIBLE FOR ANY CHANGES OR MODIFICATIONS NOT EXPRESSLY APPROVED BY THE PARTY RESPONSIBLE FOR COMPLIANCE. SUCH MODIFICATIONS COULD VOID THE USER'S AUTHORITY TO OPERATE THE EQUIPMENT.

NOTE: This equipment has been tested and found to comply with the limits for a Class B digital device, pursuant to part 15 of the FCC Rules. These limits are designed to provide reasonable protection against harmful interference in a residential installation. This equipment generates uses and can radiate radio frequency energy and, if not installed and used in accordance with the instructions, may cause harmful interference to radio communications. However, there is no guarantee that interference will not occur in a particular installation. If this equipment does cause harmful interference to radio or television reception, which can be determined by turning the

equipment off and on, the user is encouraged to try to correct the interference by one or more of the following measures:

- Reorient or relocate the receiving antenna.
- Increase the separation between the equipment and receiver.
- Connect the equipment into an outlet on a circuit different from that to which the receiver is connected.
- Consult the dealer or an experienced radio/TV technician for help.

ZenCrate by Plug and Play Robotics

2901 West Cypress Creek Road #102 Fort Lauderdale, FL 33309 support@zendogcrate.com